

TRIFAB® VERSAGLAZE®
450/451/451T FRAMING SYSTEM
Installation Instructions - Screw Spline
Fabrication

May 2020

451VG970EN



This page is intentionally left blank.

Table of Contents

INTRODUCTION	5
Contacting Kawneer	5
Conventions Used in this Document	5
Safety Notices	6
General Installation Notes	6
Handling, Storage, and Protection of Aluminum	7
BASIC FRAMING DETAILS	8
Inside Glazed Details (Stops Down)	9
Outside Glazed Details (Stops Down)	10
Outside Glazed Details (Stops Down)	11
TRIFAB® VERSAGLAZE® 450 FRAME FABRICATION AND ASSEMBLY	12
Screw Spline Preps for Trifab® VersaGlaze® 450 Center Option	12
Screw Spline Preps for Trifab® VersaGlaze® 450 Front or Back Option	13
Horizontals Fabrication for Trifab® VersaGlaze® 450	14
Trifab® VersaGlaze® 450 Screw Spline Assembly	15
Shear Block Preps for Trifab® VersaGlaze® 450 Center Option	16
Horizontals Fabrication for Trifab® VersaGlaze® 450 Shear Block Center Option	17
Shear Block Preps for Trifab® VersaGlaze® 450 Front or Back Option	19
Horizontals Fabrication for Trifab® VersaGlaze® 450 Shear Block Front or Back Option	20
Trifab® VersaGlaze® 450 Shear Block Door Jamb and Sidelite Assembly	23
TRIFAB® VERSAGLAZE® 451/451T FRAME FABRICATION AND ASSEMBLY	25
Screw Spline Preps for Trifab® VersaGlaze® 451/451T Center Option	25
Screw Spline Preps for Trifab® VersaGlaze® 451/451T Front or Back Option	26
Horizontals Fabrication for Trifab® VersaGlaze® 451/451T	27
Trifab® VersaGlaze® 451/451T Screw Spline Assembly	28
Shear Block Preps for Trifab® VersaGlaze® 451/451T Center Option	29
Horizontals Fabrication for Trifab® VersaGlaze® 451/451T Shear Block Center Option	31
Shear Block Preps for Trifab® VersaGlaze® 451/451T Front or Back Option	33
Horizontals Fabrication for Trifab® VersaGlaze® 451/451T Shear Block Front or Back Option	34
Trifab® VersaGlaze® 451/451T Shear Block Door Jamb and Sidelite Assembly	37
SILL FLASHING	39
Sill Flashing Fabrication	39
Sill Flashing Splice	41
Sill Flashing Installation	44
Sill Flashing at Door Jamb	45
Sill Flashing at Corners	46
Frame Installation	47
Sill to Sill Flashing Anchor Schedule	48

Shim Installation	49
HEAD RECEPTOR	50
Head Receptor Splice Installation	50
Head Receptor Installation	51
Head Receptor End Dam Placement	51
Head Receptor Silicone Sealant	52
Jamb Receptor and Sill Flashing Joints	52
Install Water Deflector	53
GLAZING	56
Install Glazing Adapters for Trifab® VersaGlaze® 451/451T	56
Glazing Charts	61
"W" Side Block Installation	62
Gasket and Glass Stop Installation	63
OPTIONAL CORNERS	65
Adjustable Corners	65
Pivoted Inside and Outside 155° to 180° Corners	65
Snap Corners	66
90° Dart Corners	66
135° Dart Corners	71
Expansion Mullion	76
Steel Reinforcing	77
Adjustable Narrow Sidelite Base	77
Wide Sidelite Base for Center Glazed Option	80
451CG001 Sill for Center Glazed Option	81
Brake Metal Adapter at Sill for Center Glazed Option	82
4-1/2" x 4-1/2" Sill for Center Glazed Option	83
Notes and Disclaimers	86

INTRODUCTION

These instructions show the general installation sequence and procedure for typical installation. Installation Instructions are a supplement to the approved shop drawings and notations on installation and glazing. Use in conjunction with those drawings.



Consult the KawneerDirect website for the latest updates to these instructions before beginning work on your project.

Contacting Kawneer

For contact information, visit .

Conventions Used in this Document

These symbols identify special types of information that can help you use the document more effectively.





Symbol	Description
 NOTE	Denotes general information that provides additional context or guidance
 IMPORTANT	Denotes information to which you should pay special attention
 TIP	Denotes information that can help you perform a task more efficiently

Metric (SI) Conversion. Metric (SI) conversion figures are included throughout this document for reference. Numbers in parentheses () are millimeters unless otherwise noted. The following metric (SI) units may also appear: m – meter; cm – centimeter; mm – millimeter; s – second; Pa – pascal; MPa – megapascal.

Artwork Typical. Fabrication, installation, and glazing artwork depicts typical 1" front glazed members. All 1/4" infill and 1" front, back, and multi-plane applications are similar unless otherwise noted. Outside glazing is typically shown unless otherwise noted.

Safety Notices

These symbols identify hazards and conditions related to personal safety and equipment.

Symbol	Description
 DANGER	Indicates an imminent hazard that will result in death
 WARNING	Indicates a hazard that can result in serious personal injury or death
 CAUTION	Indicates a hazard that can result in personal injury
 NOTICE	Indicates a situation that can result in equipment or property damage, but poses no risk of personal injury

General Installation Notes

These practices are recommended for all installations:

- **CHECK SHOP DRAWINGS, INSTALLATION INSTRUCTIONS and GLAZING INSTRUCTIONS** to become thoroughly familiar with the project:
 - The Shop Drawings take precedence and include specific details for the project.
 - The Installation Instructions are of a general nature and cover most common conditions.
- All materials are to be **INSTALLED PLUMB, LEVEL, AND TRUE**.
- All work should start from bench marks and/or column lines as established by the **ARCHITECTURAL DRAWINGS** and the **GENERAL CONTRACTOR**.
- Check mullion spacing from both ends of masonry opening to prevent dimensional build-up of daylight opening.
- Make certain that construction which will receive your materials is in accordance with the contract documents. If not, notify the General Contractor *in writing* and resolve differences before proceeding with your work.
- Isolate all aluminum to be placed directly in contact with uncured masonry or incompatible materials with a heavy coat of zinc chromate or bituminous paint.
- Check all materials on arrival for quantity and be sure you have everything required to begin installation.
- **SEALANTS**. Sealants must be compatible with all materials with which they have contact, including other sealant surfaces. Consult with sealant manufacturer for recommendations relative to joint size, shelf life, compatibility, priming, tooling, adhesion, and so on.
- **POURED AND DE-BRIDGED SECTIONS**. Do not drill, punch, penetrate or alter the urethane thermal break in anyway.
- **ISOWEB® THERMALLY BROKEN SECTIONS**. Do not drill, punch, penetrate or alter the polyamide thermal break in anyway.

- **FASTENERS.** The term "fastening" refers to any method of securing one part to another part or to adjacent materials. These instructions specify only those fasteners used within the system. Due to varying perimeter conditions and job performance requirements, anchor fasteners are not specified in these instructions. For anchor fastening, refer to the Shop Drawings or consult the fastener supplier.
- **PERIMETER FASTENERS.** The term "fastening" refers to any method of securing one part to another part or to adjacent materials. These instructions specify only those fasteners used within the system. Due to varying perimeter conditions and job performance requirements, anchor fasteners are not specified in these instructions. For anchor fastening, refer to the Shop Drawings or consult a structural engineer for fastener type, sizing, and location.
- **CHECK OPENINGS.** Make certain that the opening which will receive your materials is in accordance with the contract documents. If not, notify the General Contractor *in writing* and resolve differences before proceeding with your work.
- **BUILDING CODES.** Glass and glazing codes governing the design and use of products vary widely. Kawneer does not control the selection of product configurations, operating hardware, or glazing materials, and assumes no responsibility for these design considerations. It is the responsibility of the owner, specification writer, architect, general contractor, and the installer to make these selections in strict conformance with all applicable codes.
- **EXPANSION JOINTS.** Expansion joints and perimeter seals shown in these instructions and in the shop drawings are shown at normal size. Actual dimensions may vary due to perimeter conditions and/or difference in metal temperature between the time of fabrication and time of installation. For example, a 12-foot unrestrained length of aluminum extrusion can expand or contract 3/32" (2.4) over a 50° F temperature change. Any movement potential should be accounted for at the time of installation.
- **FIELD TESTING.** It is recommended that a Water Hose Test be conducted once a sufficient portion of the framing is installed, glazed, and caulked to ensure proper installation. The Water Hose test shall be conducted in accordance with AAMA 501.2. In addition, larger projects should have periodic Water Hose Tests as additional precautionary measures.
- **GASKET INVENTORY ROTATION.** These high quality rubber extrusions are coated with silicone lubricant. Silicone will dry over time, leaving a white "chalky" residue. Please rotate your stock on a "FIRST IN - FIRST OUT" basis. If the rubber becomes dry, you may use water ONE TIME to reconstitute the silicone. After that, use a soap-water solution.

Handling, Storage, and Protection of Aluminum

Protect materials against damage. Follow these precautions to assure early acceptance of your products and workmanship:

- **HANDLE CAREFULLY:**

**CAUTION**

Wear proper hand protection when handling materials. Glass and sharp edges of extrusions can cause cuts and lacerations. Failure to observe this caution may result in personal injury.

- Do not drop or drag from the truck.
- Stack with adequate separation so materials will not rub together.
- Store off the ground. Protect against elements and other construction trades.
- **KEEP MATERIAL AWAY FROM WATER, MUD, AND SPRAY.** Prevent cement, plaster, or other materials from damaging the finish.
- **PROTECT THE MATERIALS AFTER ERECTION.** Wrap with Kraft paper or erect Visqueen or canvas splatter screen. Cement, plaster, terrazzo, other alkaline solutions, and acid-based materials used to clean masonry are very harmful to the finish and should be removed with water and mild soap IMMEDIATELY.

BASIC FRAMING DETAILS

The Screw Spline System is a fabrication and erection method that permits the pre-assembly of single units in the shop or at the job site. These units are then erected by mating the male mullion half of one unit with the female half of the unit already installed.

Inside Glazed Details (Stops Down)

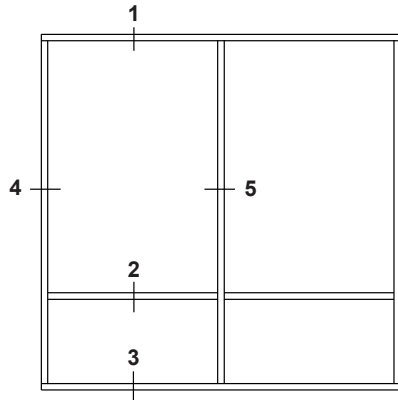

Elevation is number-keyed to details

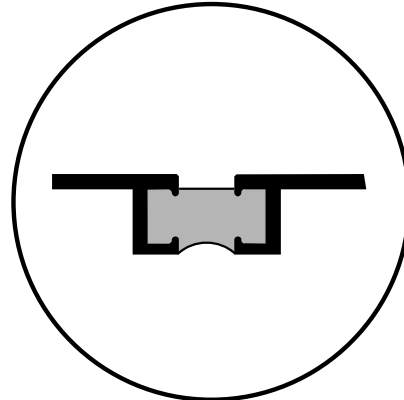

Trifab® VG 451T: Thermally Broken Members

CENTER		FRONT		BACK	
4 JAMB	5 VERTICAL	4 JAMB	5 VERTICAL	4 JAMB	5 VERTICAL
1 HEAD		1 HEAD		1 HEAD	
2 HORIZONTAL		2 HORIZONTAL		2 HORIZONTAL	
3 SILL		3 SILL		3 SILL	

Outside Glazed Details (Stops Down)

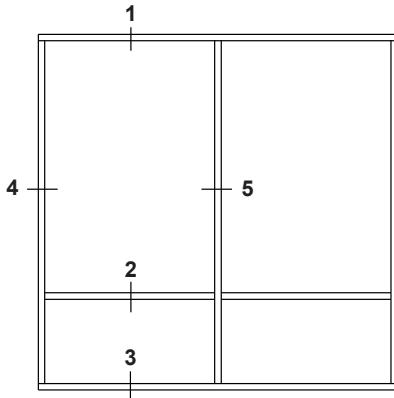

Elevation is number-keyed to details

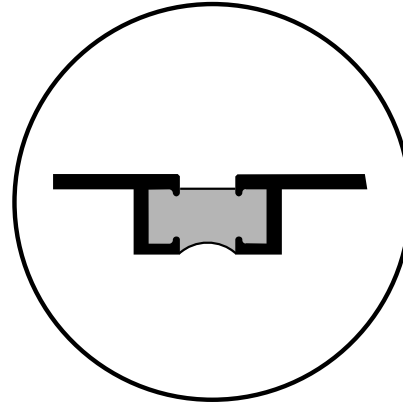

Trifab® VG 451T: Thermally Broken Members

CENTER		FRONT		BACK	
4 JAMB	5 VERTICAL	4 JAMB	5 VERTICAL	4 JAMB	5 VERTICAL
1 HEAD		1 HEAD		1 HEAD	
2 HORIZONTAL		2 HORIZONTAL		2 HORIZONTAL	
3 SILL		3 SILL		3 SILL	

Outside Glazed Details (Stops Down)

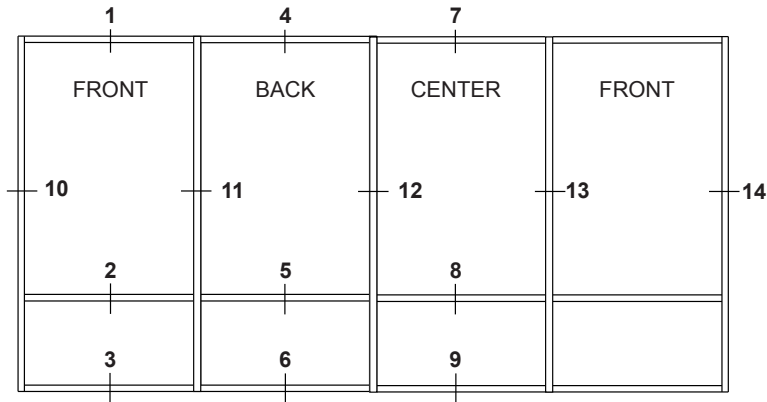

Elevation is number-keyed to details

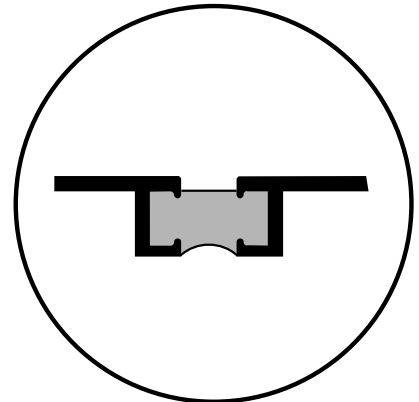

Trifab® VG 451T: Thermally Broken Members

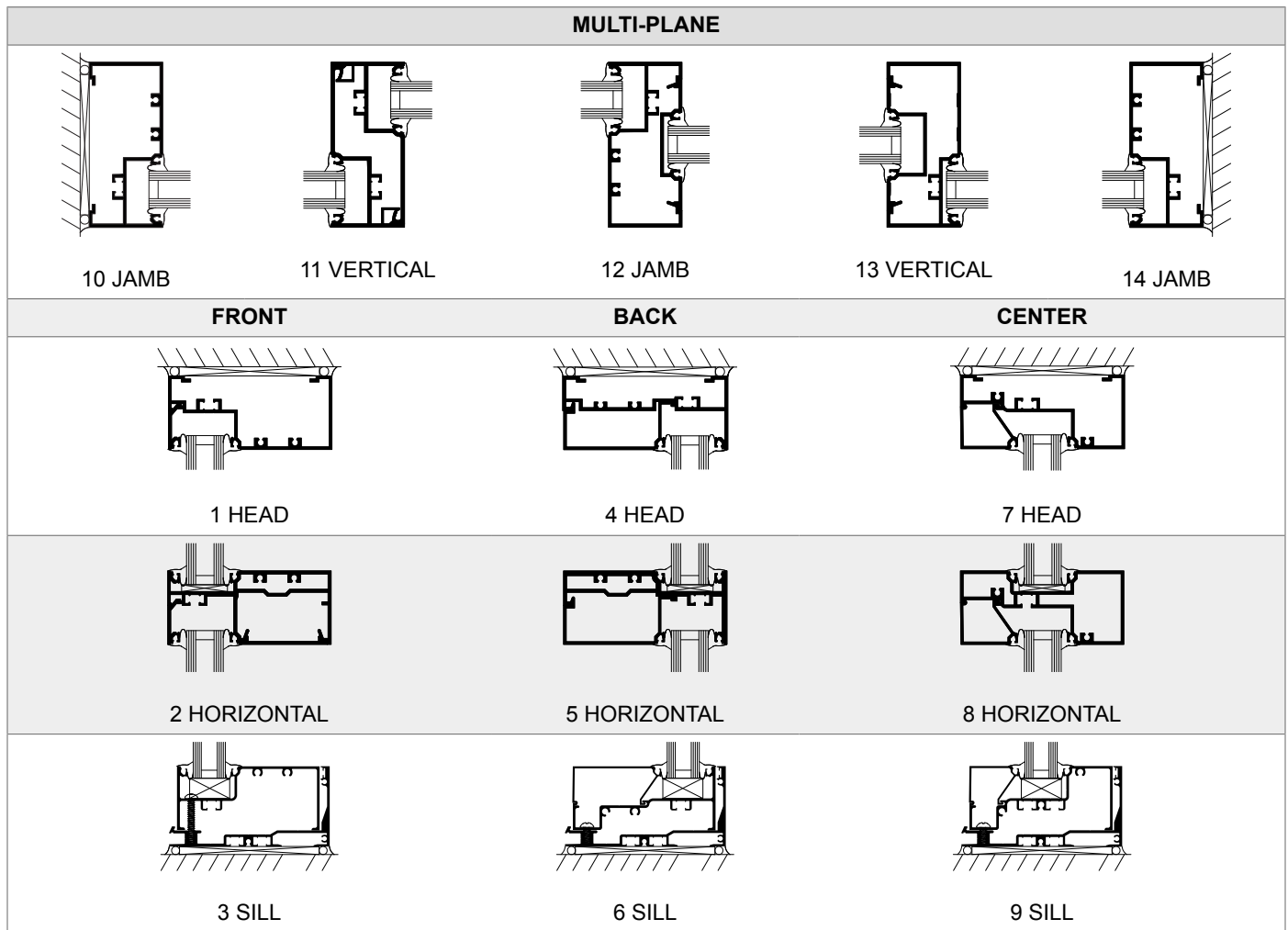

TRIFAB® VERSAGLAZE® 450 FRAME FABRICATION AND ASSEMBLY

Use the instructions in the following sections to perform:

- Screw Spline Mullion Fabrication for Center Option
- Horizontals Fabrication for Center Option
- Screw Spline Mullion Fabrication for Front or Back Option
- Horizontals Fabrication for Front or Back Option
- Screw Spline Assembly
- Shear Block Joinery for Entrances

Screw Spline Preps for Trifab® VersaGlaze® 450 Center Option

1. Measure minimum height of opening.
2. Cut vertical members to length, $L = H_{min} - 1-1/4" (31.8)$, where H_{min} = minimum opening height.



NOTICE

- Approved shop drawings always take precedence over the formula shown.
- For uncertain job conditions or irregular masonry openings, add extra clearance for construction tolerance.
- Formula shown includes 1/2" (12.7) sill flashing height as well as 3/8" (9.5) head clearance and 3/8" (9.5) sill clearance to ease installation and provide space for caulking.

3. At desired horizontal locations, drill spline screw holes in vertical members.
 - a. Place jig into mullion as shown below.
 - b. Use #1 drill to make holes according to key below.

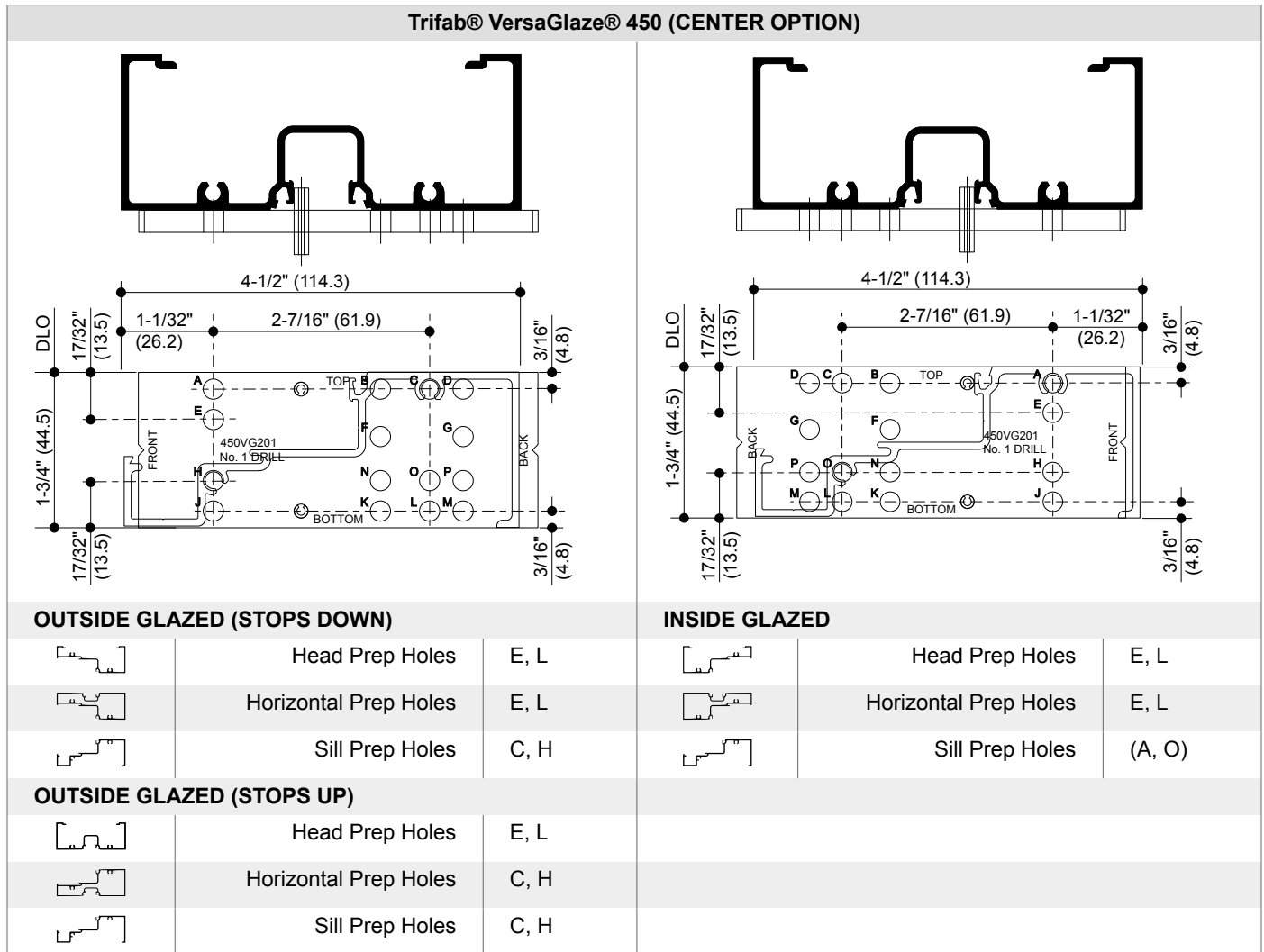

Screw Spine Preps for Trifab® VersaGlaze® 450 Front or Back Option

1. Measure minimum height of opening.
2. Cut vertical members to length, $L = H_{min} - 1-1/4" (31.8)$, where H_{min} = minimum opening height.



NOTICE

- Approved shop drawings always take precedence over the formula shown.
- For uncertain job conditions or irregular masonry openings, add extra clearance for construction tolerance.
- Formula shown includes 1/2" (12.7) sill flashing height as well as 3/8" (9.5) head clearance and 3/8" (9.5) sill clearance to ease installation and provide space for caulking.

3. At desired horizontal locations, drill spline screw holes in vertical members.



TIP

Screw spline preps for mullion fillers may be completed by using a 2" (50.8) piece of mullion to support drill jig or by locating the horizontal at the vertical dimensions shown above, and drilling at the "V" grooves in the extrusions.

- a. Place jig into mullion as shown below.
- b. Use #1 drill to make holes according to key below.

Trifab® VersaGlaze® 450 (FRONT OPTION)			Trifab® VersaGlaze® 450 (BACK OPTION)		
OUTSIDE GLAZED			OUTSIDE GLAZED		
	Head Prep Holes	K, M		Head Prep Holes	F, G
	Horizontal Prep Holes	B, D		Horizontal Prep Holes	B, D
	Sill Prep Holes	B, D		Sill Prep Holes	N, P
INSIDE GLAZED			INSIDE GLAZED		
	Head Prep Holes	F, G		Head Prep Holes	K, M
	Horizontal Prep Holes	B, D		Horizontal Prep Holes	B, D
	Sill Prep Holes	B, D		Sill Prep Holes	N, P

Horizontals Fabrication for Trifab® VersaGlaze® 450

- 1. Cut horizontals to length, $L_{HORIZ} = \text{Daylight Opening (DLO)}$.
- 2. Cut glass stops to length, $L_{GLASS STOP} = DLO - 1/16" (1.6)$.

3. Drill sill holes.
 - a. Drill 0.201" (#7 drill) clear holes in sill for anchoring to sill flashing.



NOTE

See "Sill to Sill Flashing Anchor Schedule" for hole spacing dimensions.

- b. Drill 5/16" weep holes at 1/4 points of sill to align with 5/16" holes in sill flashing.



NOTE

Sill weep holes are not required for front option assemblies.

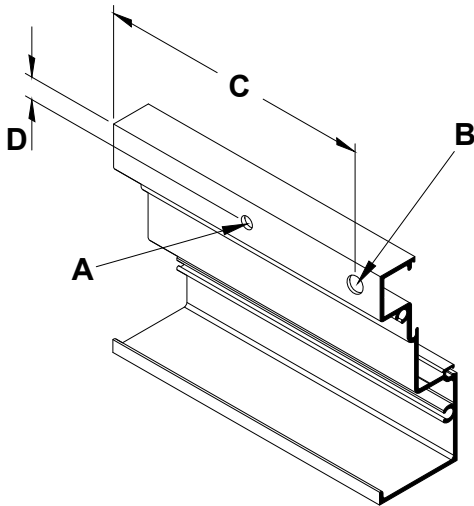

A	0.201" (#7 drill) clear anchor hole
B	5/16" weep hole
C	1/4 point
D	0.442" (11.2) or interior V-groove

Trifab® VersaGlaze® 450 Screw Spline Assembly



NOTICE

When an entrance is required, shear block joinery must be used to attach horizontals to the immediate door frame. The other side of the sidelite will be fabricated for screw spline joinery as usual. See Shear Block Fabrication and Assembly.

1. Apply sealant to ends of all horizontal members and glazing reglets to ensure a good seal to vertical members.

2. Assemble each unit to include:
 - at least one deep vertical pocket; and
 - both a male and a female mullion half.
3. Secure units using two (2) 028856 screws at each joint as shown.

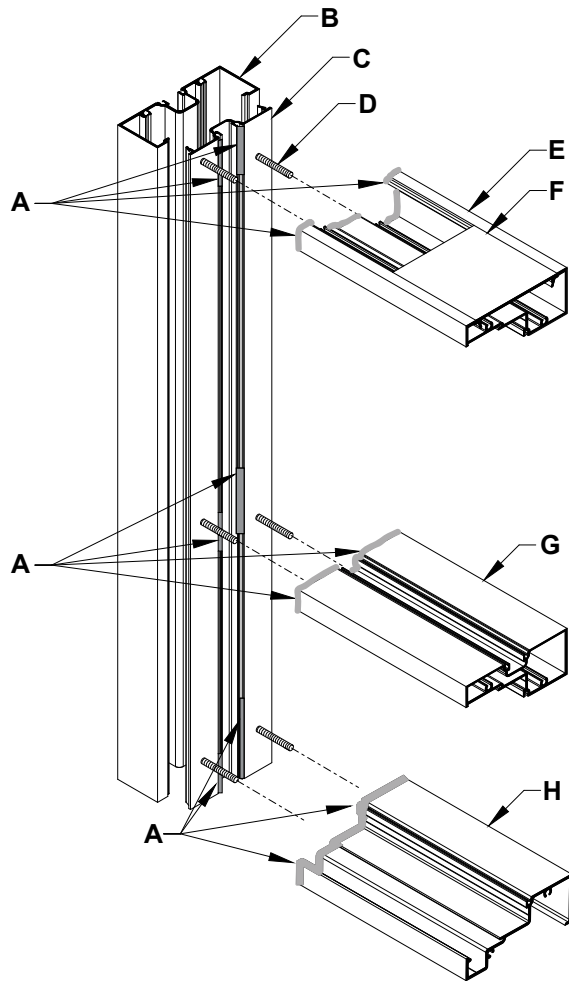

A	Sealant
B	Screw Spline Mullion
C	Snap in Filler
D	#12 x 1-1/8" Spline Screw
E	Head
F	3" (76.2) long Shim Filler
G	Intermediate Horizontal
H	Sill

Shear Block Preps for Trifab® VersaGlaze® 450 Center Option

1. At desired horizontal locations drill holes in the door jambs as shown.



IMPORTANT

Door jambs run through to perimeter at sill. Locate sill to accommodate sill flashing and shim space at sill.

- a. Place jig into mullion as shown below.
- b. Use #26 drill to make holes according to key below.

- Attach shear blocks to door jambs using #028400 (#10 X 1-19/32" P.H.) screws as needed.

Trifab® VersaGlaze® 450 (CENTER OPTION)

*** Shim Space

*** Shim Space

OUTSIDE GLAZED (STOPS DOWN)			INSIDE GLAZED		
	Head Prep Holes	A, B, K		Head Prep Holes	A, B, K
	Horizontal Prep Holes	A, B, K		Horizontal Prep Holes	A, B, K
	Sill Prep Holes	B, J, K		Sill Prep Holes	A, J, K
INSIDE GLAZED					
	Head Prep Holes	B, J, K			
	Horizontal Prep Holes	B, J, K			
	Sill Prep Holes	B, J, K			

Horizontals Fabrication for Trifab® VersaGlaze® 450 Shear Block Center Option

- Cut horizontals to length, $L_{HORIZ} = \text{Daylight Opening (DLO)}$.
- Cut glass stops to length, $L_{GLASS STOP} = DLO - 1/16"$ (1.6).

3. Drill head, sill, and intermediate horizontals.
 - a. Drill 0.201" (#7 drill) holes as shown.
 - b. Countersink drilled holes to 0.390" x 82°.

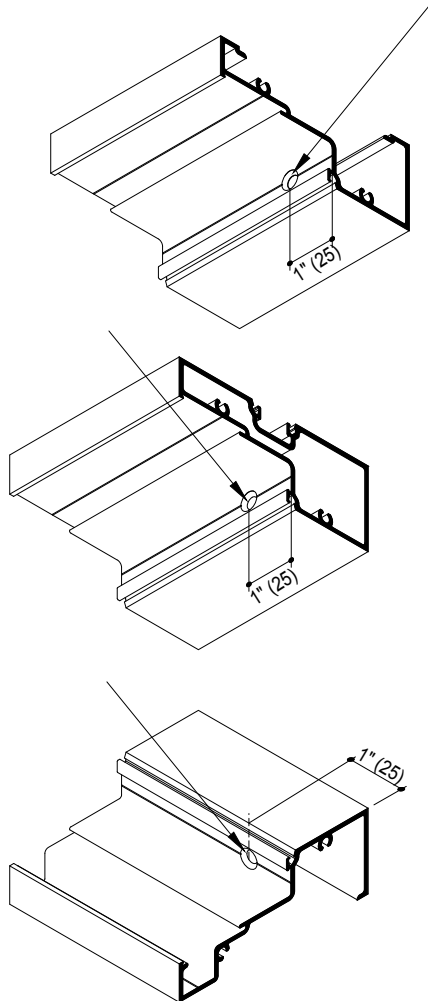

4. Drill sill holes.
 - a. Drill 0.201" (#7 drill) clear holes in sill for anchoring to sill flashing.



NOTE

See "Sill to Sill Flashing Anchor Schedule" for hole spacing dimensions.

- b. Drill 5/16" weep holes at 1/4 points of sill to align with 5/16" holes in sill flashing.



NOTE

Sill weep holes are not required for front option assemblies.

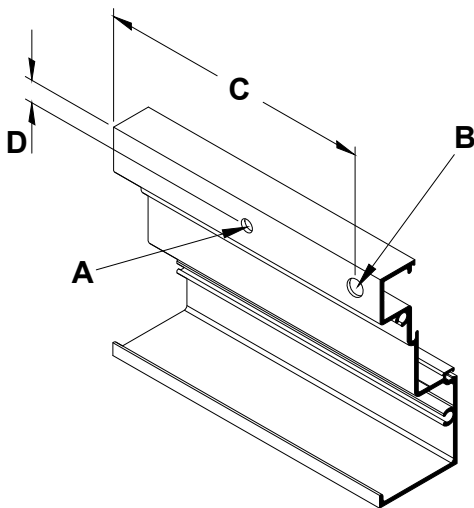

A	0.201" (#7 drill) clear anchor hole
B	5/16" weep hole
C	1/4 point
D	0.442" (11.2) or interior V-groove

Shear Block Preps for Trifab® VersaGlaze® 450 Front or Back Option

1. At desired horizontal locations drill holes in the door jambs as shown.



IMPORTANT

Door jambs run through to perimeter at sill. Locate sill to accommodate sill flashing and shim space at sill.

- a. Place jig into mullion as shown below.
 - b. Use #26 drill to make holes according to key below.

- Attach shear blocks to door jambs using #028400 (#10 X 1-19/32" P.H.) screws as needed.

Trifab® VersaGlaze® 450 (FRONT OPTION)			Trifab® VersaGlaze® 450 (BACK OPTION)		
*** Shim Space			*** Shim Space		
OUTSIDE GLAZED			OUTSIDE GLAZED		
	Head Prep Holes	G, H		Head Prep Holes	C, D
	Horizontal Prep Holes	E, F		Horizontal Prep Holes	E, F
	Sill Prep Holes	E, F		Sill Prep Holes	L
INSIDE GLAZED			INSIDE GLAZED		
	Head Prep Holes	C, D		Head Prep Holes	G, H
	Horizontal Prep Holes	E, F		Horizontal Prep Holes	E, F
	Sill Prep Holes	E, F		Sill Prep Holes	L

Horizontals Fabrication for Trifab® VersaGlaze® 450 Shear Block Front or Back Option

- Cut horizontals to length, $L_{HORIZ} = \text{Daylight Opening (DLO)}$.
- Cut glass stops to length, $L_{GLASS STOP} = DLO - 1/16"$ (1.6).

3. Drill head and sill for #10 FH screws.
 - a. Drill 0.201" (#7 drill) holes as shown.
 - b. Countersink drilled holes to 0.390" x 82°.

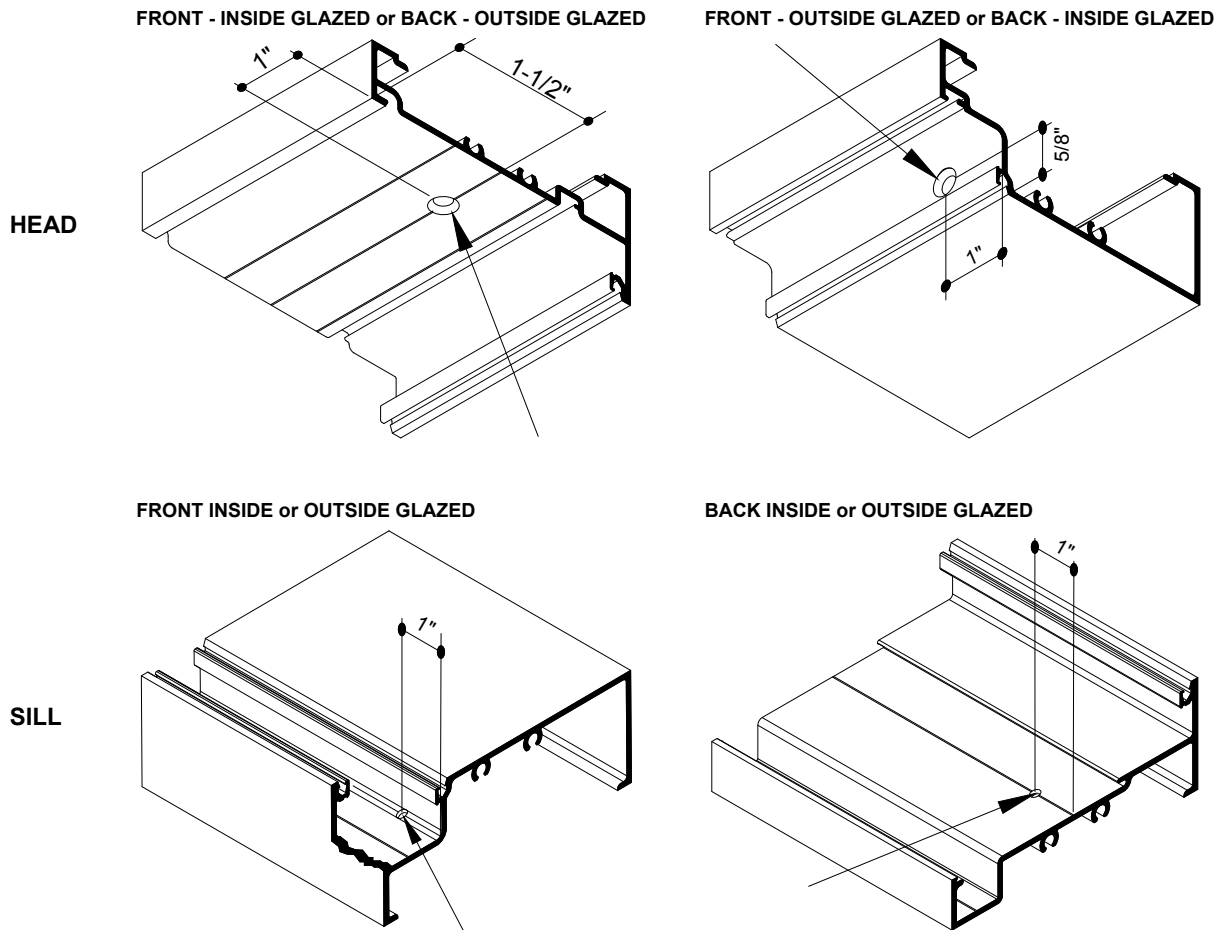

4. Drill sill holes.
- a. Drill 0.201" (#7 drill) clear holes in sill for anchoring to sill flashing.

**NOTE**

See "Sill to Sill Flashing Anchor Schedule" for hole spacing dimensions.

- b. Drill 5/16" weep holes at 1/4 points of sill to align with 5/16" holes in sill flashing.

**NOTE**

Sill weep holes are not required for front option assemblies.

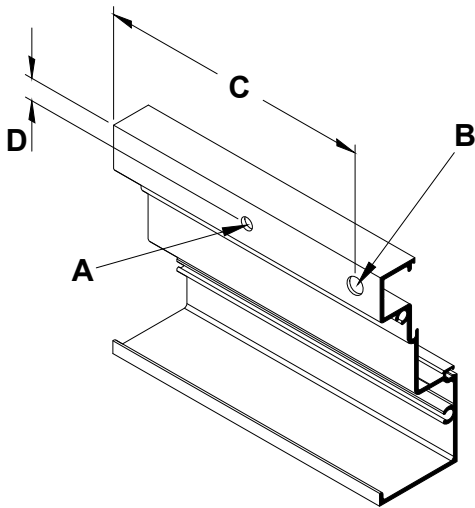

A	0.201" (#7 drill) clear anchor hole
B	5/16" weep hole
C	1/4 point
D	0.442" (11.2) or interior V-groove

Trifab® VersaGlaze® 450 Shear Block Door Jamb and Sidelite Assembly

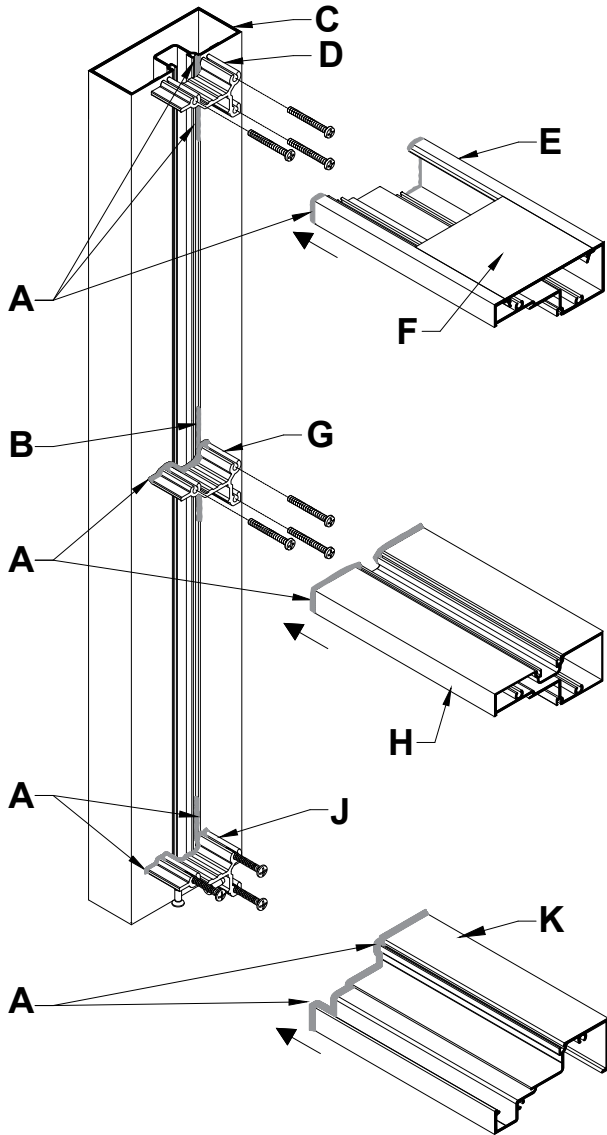

A	Sealant
B	Sealant Into Reglet
C	Door Jamb
D	Head Shear Block Package
E	Head
F	3" (76.2) long Shim Filler
G	Intermediate Horizontal Shear Block Package
H	Intermediate Horizontal
J	Sill Shear Block Package
K	Sill

1. Apply sealant to contact ends of shear blocks and to glazing reglets to ensure a good seal to vertical members.

**NOTICE**

Failure to properly seal horizontal components to vertical mullions will reduce system performance.

2. Attach shear blocks to vertical mullions.
3. Hold fabricated horizontal member over shear block and tight against vertical member.
4. Match drill (#26 drill) .147" hole into shear block.
 - For center option, offset slightly to vertical mullion side of countersunk hole in horizontal.
 - For front or back option, offset slightly to DLO side of countersunk hole in horizontal.
5. Apply sealant to ends of all horizontal members and to glazing reglets to ensure a good seal to vertical members.

**NOTICE**

Failure to properly seal horizontal components to vertical mullions will reduce system performance.

6. Attach all horizontal members to shear blocks with fasteners provided in shear block packages.
7. Install flat fillers.
 - a. Identify perimeter anchor locations.
 - 6" (152) on each side of vertical mullions
 - 24" (610) on center between vertical mullions
 - b. Insert flat fillers into head and jambs at perimeter anchor locations.
 - c. Crimp filler material to prevent plate from sliding.

TRIFAB® VERSAGLAZE® 451/451T FRAME FABRICATION AND ASSEMBLY

Use the instructions in the following sections to perform:

- Screw Spline Mullion Fabrication for Center Option
- Horizontals Fabrication for Center Option
- Screw Spline Mullion Fabrication for Front or Back Option
- Horizontals Fabrication for Front or Back Option
- Screw Spline Assembly
- Shear Block Joinery for Entrances

Screw Spline Preps for Trifab® VersaGlaze® 451/451T Center Option

1. Measure minimum height of opening.
2. Cut vertical members to length, $L = H_{min} - 1-1/4" (31.8)$, where H_{min} = minimum opening height.



NOTICE

- Approved shop drawings always take precedence over the formula shown.
- For uncertain job conditions or irregular masonry openings, add extra clearance for construction tolerance.
- Formula shown includes 1/2" (12.7) sill flashing height as well as 3/8" (9.5) head clearance and 3/8" (9.5) sill clearance to ease installation and provide space for caulking.

3. At desired horizontal locations, drill spline screw holes in vertical members.
 - a. Place jig into mullion as shown below.
 - b. Use #1 drill to make holes according to key below.

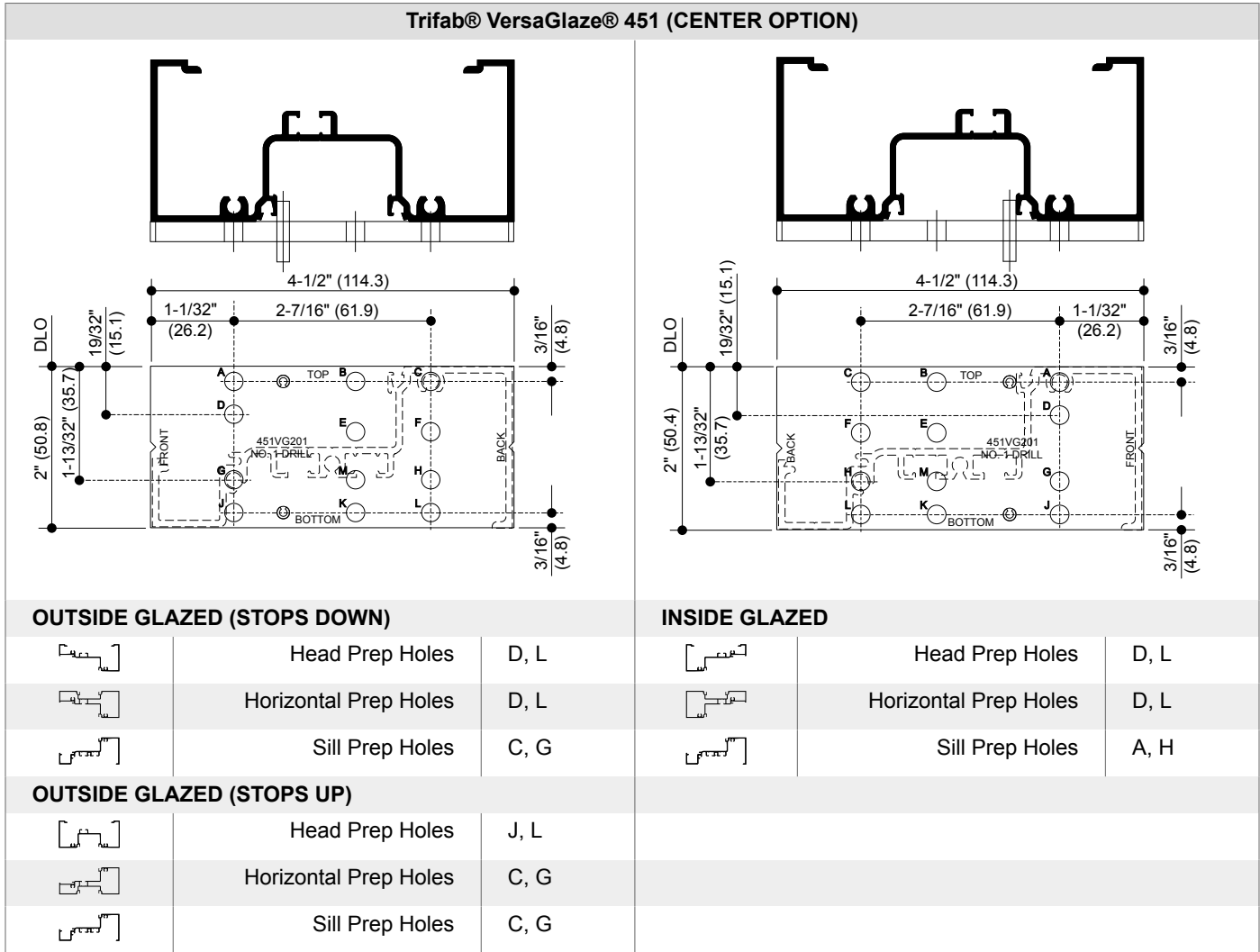

Screw Spline Preps for Trifab® VersaGlaze® 451/451T Front or Back Option

1. Measure minimum height of opening.
2. Cut vertical members to length, $L = H_{min} - 1-1/4" (31.8)$, where H_{min} = minimum opening height.

i NOTICE

- Approved shop drawings always take precedence over the formula shown.
- For uncertain job conditions or irregular masonry openings, add extra clearance for construction tolerance.
- Formula shown includes 1/2" (12.7) sill flashing height as well as 3/8" (9.5) head clearance and 3/8" (9.5) sill clearance to ease installation and provide space for caulking.

3. At desired horizontal locations, drill spline screw holes in vertical members.



TIP

Screw spline preps for mullion fillers may be completed by using a 2" (50.8) piece of mullion to support drill jig or by locating the horizontal at the vertical dimensions shown above, and drilling at the "V" grooves in the extrusions.

- a. Place jig into mullion as shown below.
- b. Use #1 drill to make holes according to key below.

Trifab® VersaGlaze® 451 (FRONT OPTION)			Trifab® VersaGlaze® 451 (BACK OPTION)		
OUTSIDE GLAZED			OUTSIDE GLAZED		
	Head Prep Holes	K, L		Head Prep Holes	E, F
	Horizontal Prep Holes	B, C		Horizontal Prep Holes	B, C
	Sill Prep Holes	B, C		Sill Prep Holes	H, M
INSIDE GLAZED			INSIDE GLAZED		
	Head Prep Holes	E, F		Head Prep Holes	K, L
	Horizontal Prep Holes	B, C		Horizontal Prep Holes	B, C
	Sill Prep Holes	B, C		Sill Prep Holes	H, M

Horizontals Fabrication for Trifab® VersaGlaze® 451/451T

- 1. Cut horizontals to length, $L_{HORIZ} = \text{Daylight Opening (DLO)}$.
- 2. Cut glass stops to length, $L_{GLASS STOP} = \text{DLO} - 1/16" (1.6)$.

3. Drill sill holes.
 - a. Drill 0.201" (#7 drill) clear holes in sill for anchoring to sill flashing.

**NOTE**

See "Sill to Sill Flashing Anchor Schedule" for hole spacing dimensions.

- b. Drill 5/16" weep holes at 1/4 points of sill to align with 5/16" holes in sill flashing.

**NOTE**

Sill weep holes are not required for front option assemblies.

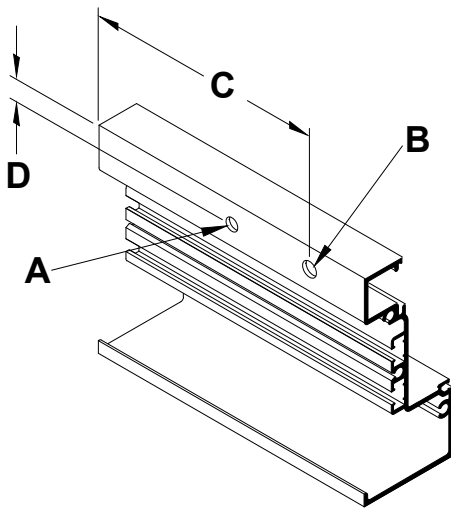

A	0.201" (#7 drill) clear anchor hole
B	5/16" weep hole
C	1/4 point
D	0.442" (11.2) or interior V-groove

Trifab® VersaGlaze® 451/451T Screw Spline Assembly

**NOTICE**

When an entrance is required, shear block joinery must be used to attach horizontals to the immediate door frame. The other side of the sidelite will be fabricated for screw spline joinery as usual. See Shear Block Fabrication and Assembly.

1. Apply sealant to ends of all horizontal members and glazing reglets to ensure a good seal to vertical members.

2. Assemble each unit to include:
 - at least one deep vertical pocket; and
 - both a male and a female mullion half.
3. Secure units using two (2) 028856 screws at each joint as shown.

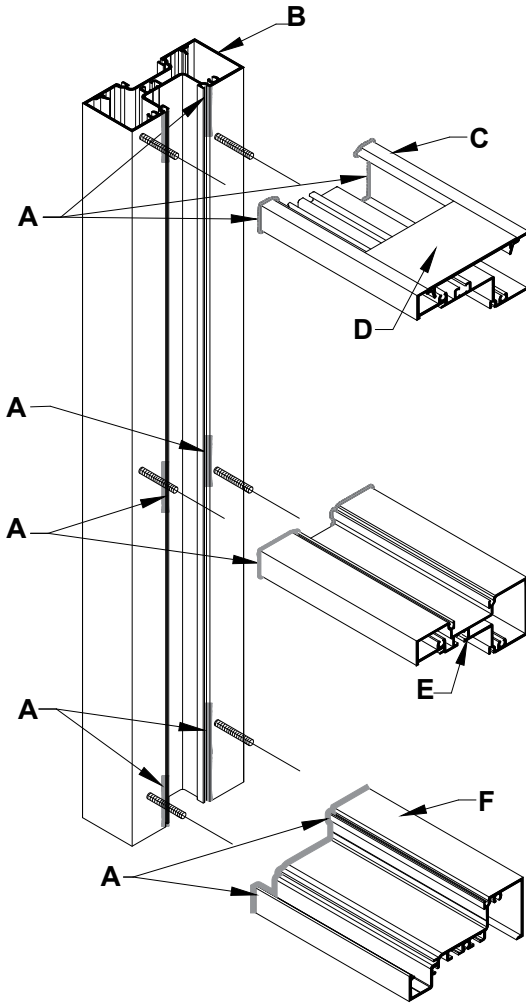

A	Sealant
B	Door Jamb
C	Head
D	3" (76.2) long Shim Filler
E	Intermediate Horizontal
F	Sill

Shear Block Preps for Trifab® VersaGlaze® 451/451T Center Option

1. At desired horizontal locations drill holes in the door jambs as shown.



IMPORTANT

Door jambs run through to perimeter at sill. Locate sill to accommodate sill flashing and shim space at sill.

- a. Place jig into mullion as shown below.
- b. Use #26 drill to make holes according to key below.

2. Attach shear blocks to door jambs using #028400 (#10 X 1-19/32" P.H.) screws as needed.

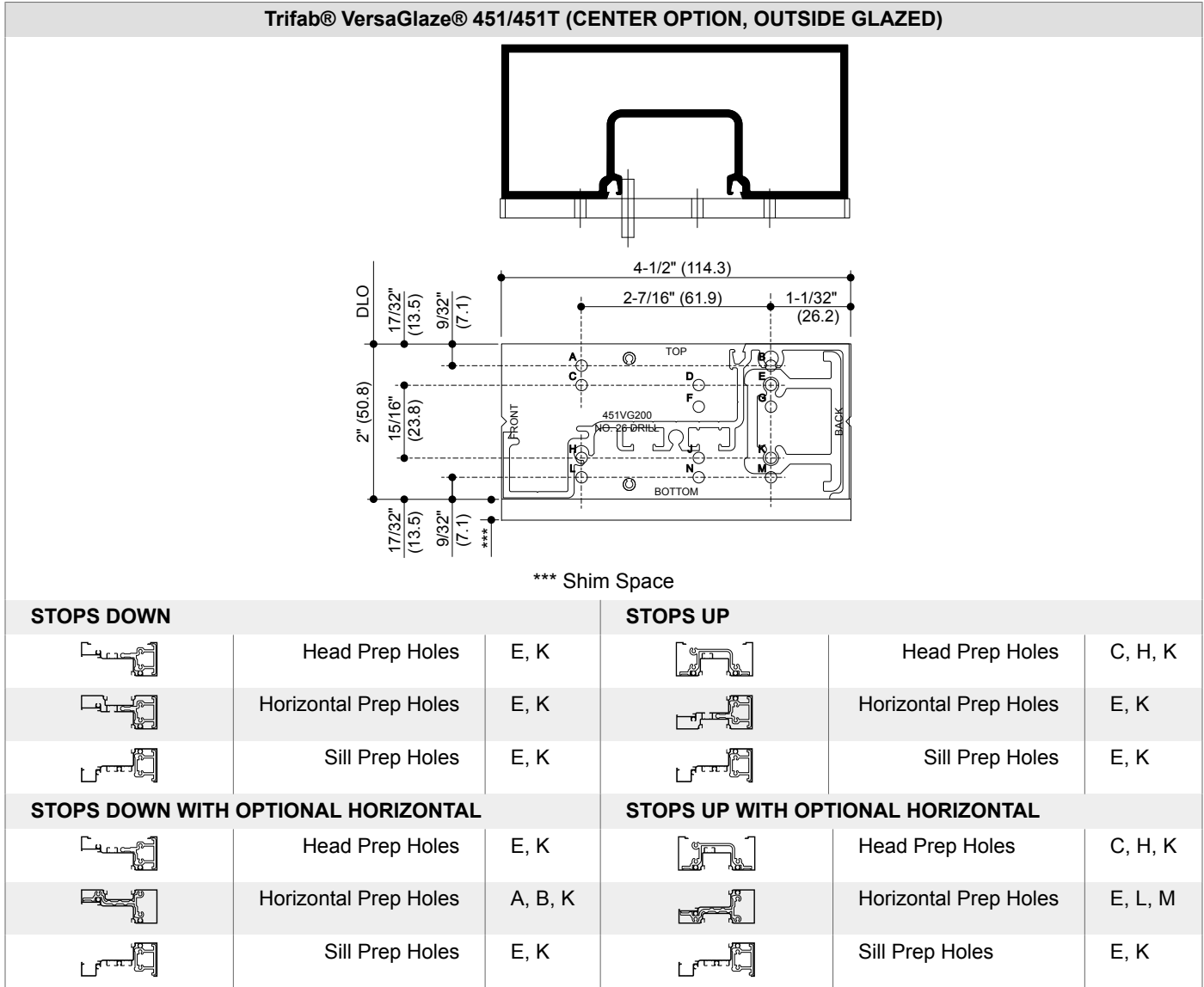

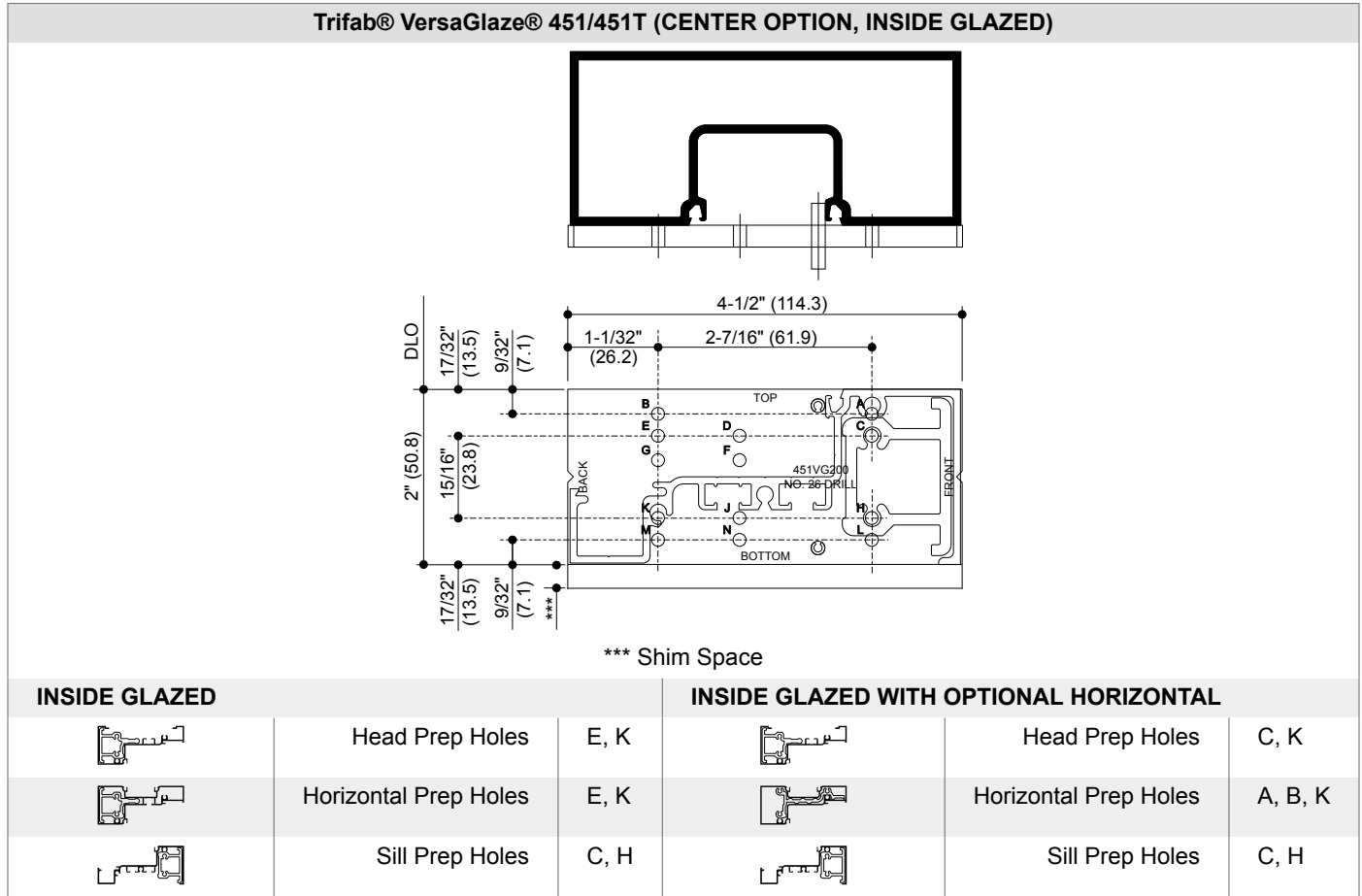

Horizontals Fabrication for Trifab® VersaGlaze® 451/451T Shear Block Center Option

1. Cut horizontals to length, $L_{HORIZ} = \text{Daylight Opening (DLO)}$.
2. Cut glass stops to length, $L_{GLASS STOP} = DLO - 1/16" (1.6)$.

3. Drill head, sill, and intermediate horizontals.
 - a. Drill 0.201" (#7 drill) holes as shown.
 - b. Countersink drilled holes to 0.390" x 82°.

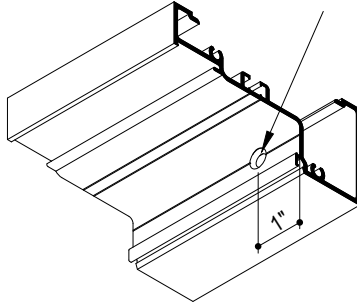

HEAD

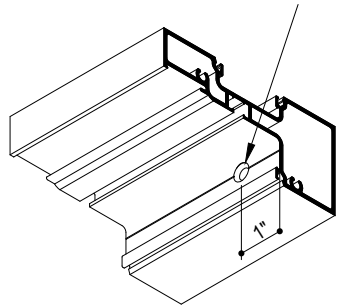

HORIZONTAL

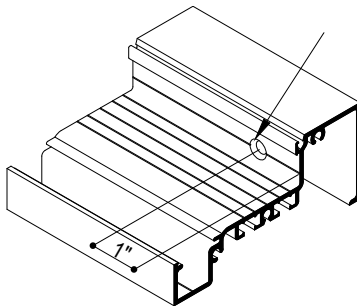

SILL

4. Drill sill holes.
 - a. Drill 0.201" (#7 drill) clear holes in sill for anchoring to sill flashing.



NOTE

See "Sill to Sill Flashing Anchor Schedule" for hole spacing dimensions.

- b. Drill 5/16" weep holes at 1/4 points of sill to align with 5/16" holes in sill flashing.



NOTE

Sill weep holes are not required for front option assemblies.

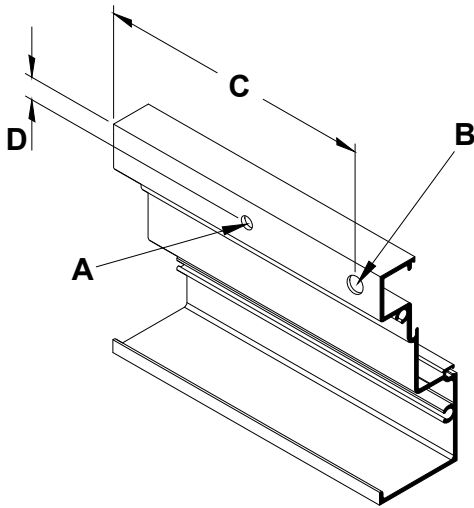

A	0.201" (#7 drill) clear anchor hole
B	5/16" weep hole
C	1/4 point
D	0.442" (11.2) or interior V-groove

Shear Block Preps for Trifab® VersaGlaze® 451/451T Front or Back Option

1. At desired horizontal locations drill holes in the door jambs as shown.



IMPORTANT

Door jambs run through to perimeter at sill. Locate sill to accommodate sill flashing and shim space at sill.

- a. Place jig into mullion as shown below.
- b. Use #26 drill to make holes according to key below.

- Attach shear blocks to door jambs using #028400 (#10 X 1-19/32" P.H.) screws as needed.

Trifab® VersaGlaze® 451 (FRONT OPTION)			Trifab® VersaGlaze® 451 (BACK OPTION)		
*** Shim Space			*** Shim Space		
OUTSIDE GLAZED			OUTSIDE GLAZED		
	Head Prep Holes	J, K		Head Prep Holes	D, E
	Horizontal Prep Holes	F, G		Horizontal Prep Holes	F, G
	Sill Prep Holes	D, E		Sill Prep Holes	N
INSIDE GLAZED			INSIDE GLAZED		
	Head Prep Holes	D, E		Head Prep Holes	J, K
	Horizontal Prep Holes	F, G		Horizontal Prep Holes	F, G
	Sill Prep Holes	D, E		Sill Prep Holes	N

Horizontals Fabrication for Trifab® VersaGlaze® 451/451T Shear Block Front or Back Option

- Cut horizontals to length, $L_{HORIZ} = \text{Daylight Opening (DLO)}$.
- Cut glass stops to length, $L_{GLASS STOP} = DLO - 1/16" (1.6)$.

3. Drill head and sill for #10 FH screws.
 - a. Drill 0.201" (#7 drill) holes as shown.
 - b. Countersink drilled holes to 0.390" x 82°.

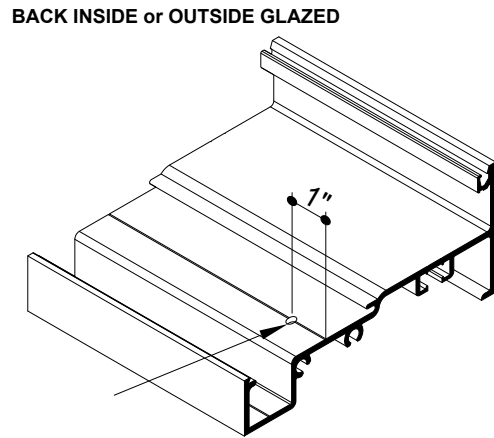
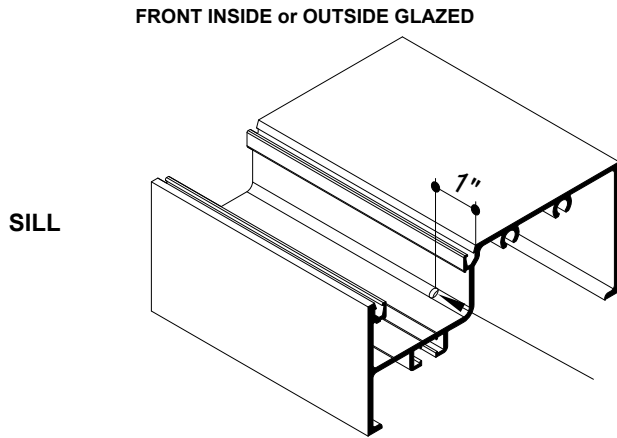
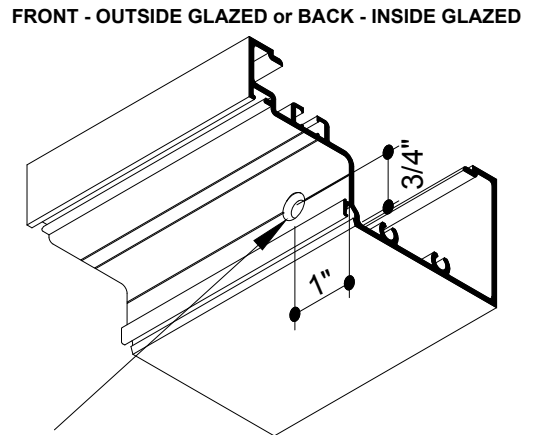
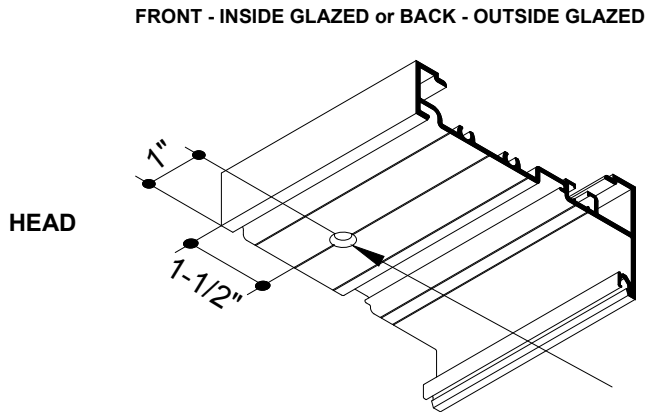

4. Drill sill holes.
- a. Drill 0.201" (#7 drill) clear holes in sill for anchoring to sill flashing.

**NOTE**

See "Sill to Sill Flashing Anchor Schedule" for hole spacing dimensions.

- b. Drill 5/16" weep holes at 1/4 points of sill to align with 5/16" holes in sill flashing.

**NOTE**

Sill weep holes are not required for front option assemblies.

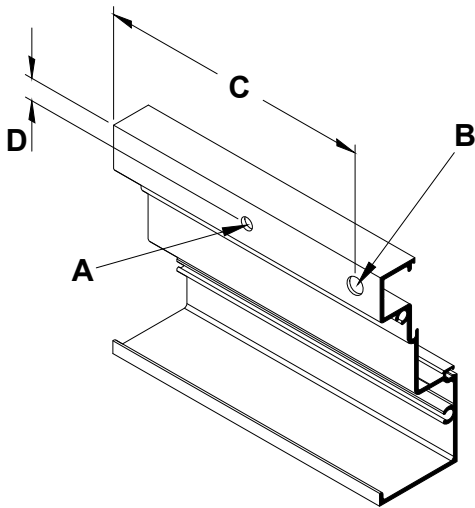

A	0.201" (#7 drill) clear anchor hole
B	5/16" weep hole
C	1/4 point
D	0.442" (11.2) or interior V-groove

Trifab® VersaGlaze® 451/451T Shear Block Door Jamb and Sidelite Assembly

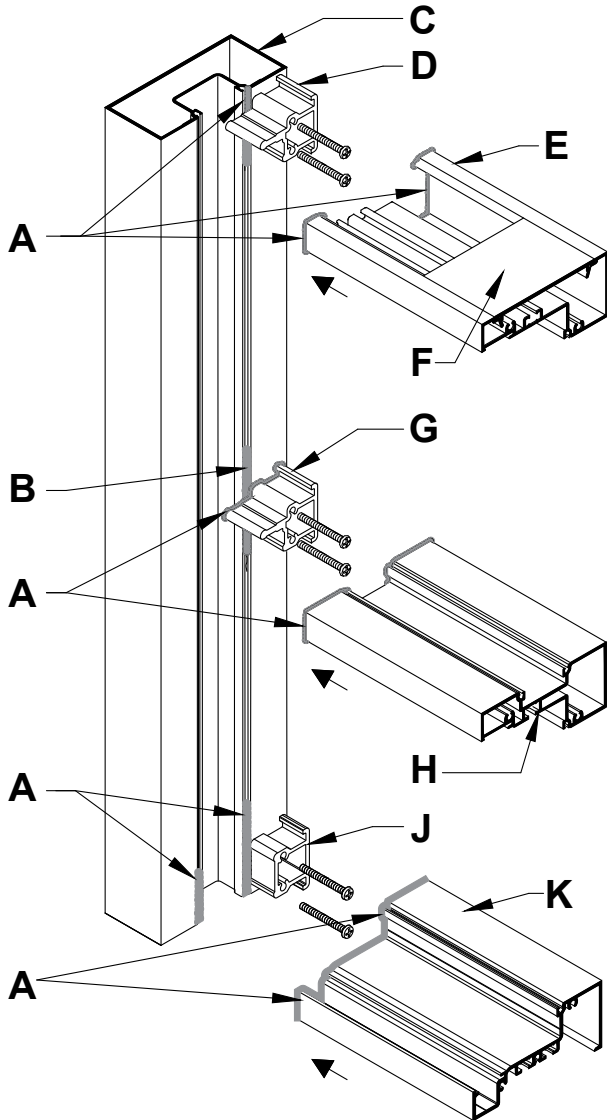

A	Sealant
B	Sealant Into Reglet
C	Door Jamb
D	Head Shear Block Package
E	Head
F	3" (76.2) long Shim Filler
G	Intermediate Horizontal Shear Block Package
H	Intermediate Horizontal
J	Sill Shear Block Package
K	Sill

1. Apply sealant to contact ends of shear blocks and to glazing reglets to ensure a good seal to vertical members.



NOTICE

Failure to properly seal horizontal components to vertical mullions will reduce system performance.

2. Attach shear blocks to vertical mullions.

3. Hold fabricated horizontal member over shear block and tight against vertical member.
4. Match drill (#26 drill) .147" hole into shear block.
 - For center option, offset slightly to vertical mullion side of countersunk hole in horizontal.
 - For front or back option, offset slightly to DLO side of countersunk hole in horizontal.
5. Apply sealant to ends of all horizontal members and to glazing reglets to ensure a good seal to vertical members.

**NOTICE**

Failure to properly seal horizontal components to vertical mullions will reduce system performance.

6. Attach all horizontal members to shear blocks with fasteners provided in shear block packages.
7. Install flat fillers.
 - a. Identify perimeter anchor locations.
 - 6" (152) on each side of vertical mullions
 - 24" (610) on center between vertical mullions
 - b. Insert flat fillers into head and jambs at perimeter anchor locations.
 - c. Crimp filler material to prevent plate from sliding.

SILL FLASHING

Sill Flashing Fabrication

1. Measure minimum width of opening.
2. Cut sill flashing to length,



NOTICE

- Approved shop drawings always take precedence over the formula shown.
 - For uncertain job conditions or irregular masonry openings, add extra clearance for construction tolerance.
 - Formula shown includes 3/8" (9.5) clearance at jambs to ease installation and provide space for caulking.
-
- For openings less than 24' (7.32 m) wide, length $L = W_{min} - 3/4"$ (19.1), where W_{min} = minimum opening width.
 - For openings greater than 24' (7.32 m) wide, refer to approved shop drawings.



NOTICE

For openings greater than 24' (7.32 m) wide, splicing is required every 12' (3.66 m) and splices must be located at the center of DLO. See Splice Joint Installation.

3. Drill perimeter anchor holes through the sill flashing.



NOTICE

- Do not drill through thermal breaks. Damage to thermal breaks will reduce thermal performance.
- Refer to shop drawings or consult Engineering for perimeter fastener size and locations.

Locate anchor holes as determined by structural calculations.

4. Drill weep holes in sill flashing.

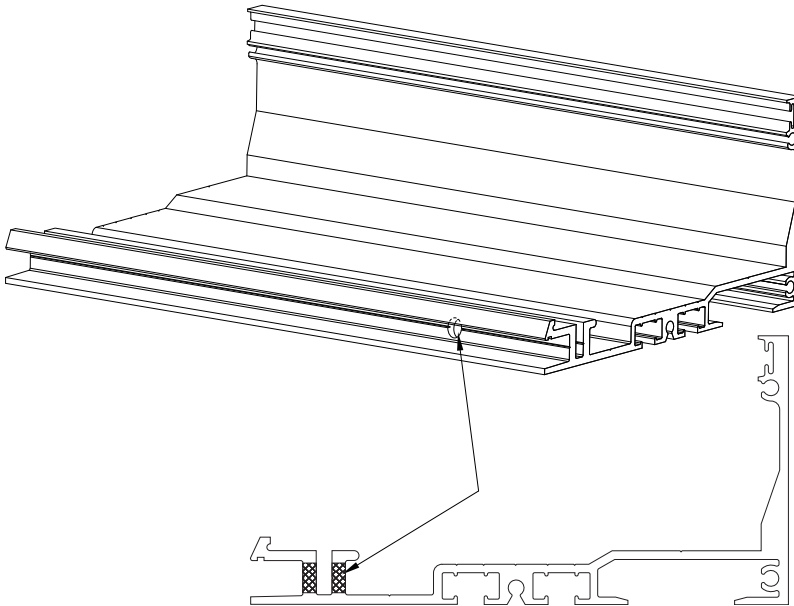

- a. Locate weep holes at 1/4 points of each DLO.
- b. Drill each 5/16" hole through both exterior face and adjacent interior wall.

5. Apply sealant or weathering.



NOTE

Either apply sealant to upturned interior leg at frame installation or install 127043 weathering before attaching end dams.

6. Attach end dams.

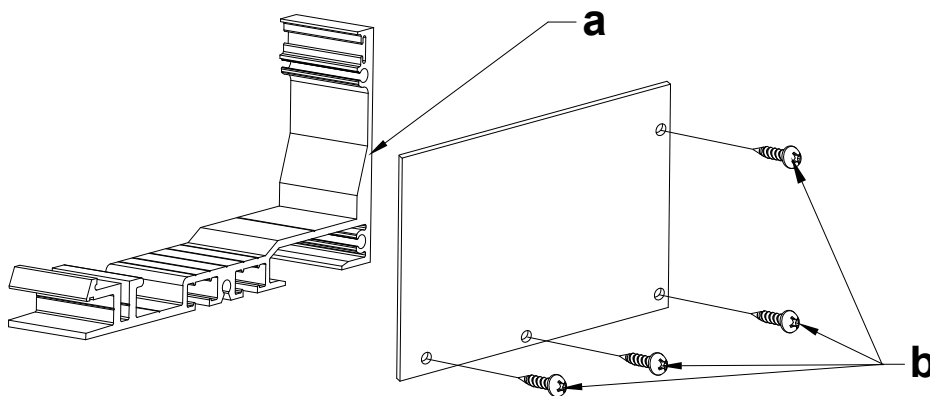

- a. Apply sealant to entire end of sill flashing.
- b. Secure end dams to flashing with four 028808 (#8 x 1/2" PHTF) supplied screws.
- c. Seal over fastener heads.
- d. Tool sealant between sill flashing and end dam inside and out.

Sill Flashing Splice



NOTICE

- Before beginning splice, clean and prime joint following silicone supplier recommendations.
- Silicone must be tested and approved for compatibility by the sealant manufacturer.
- Install splices every 12' (3.66 m) when flashing is over 24' (7.32 m).
- Locate splice sleeves at the center of a DLO.
- Do NOT locate splice sleeves at mullions.
- If there is an entrance, install entrance frame and attached sidelite(s) first, being careful to locate them accurately in the opening. Fasten entrance frame to perimeter condition as needed using the required perimeter fasteners.

1. Cut 2-1/4" silicone splice sleeve (127178) to 7" (177.8) long.
2. Clean splice area with solvent.



NOTICE: COLD WEATHER INSTALLATION

For temperatures below 40°, prepare aluminum surfaces just prior to installing. Wipe with a solvent or cleaning solution recommended by the sealant manufacturer to remove any condensation or frost.



REFER TO SAFETY DATA SHEET (SDS)

Carefully follow recommendations contained in the safety data sheet (SDS) provided by the solvent/cleaning solution manufacturer regarding health and fire/explosion risks.

3. Apply sealant to flashing and within joint.

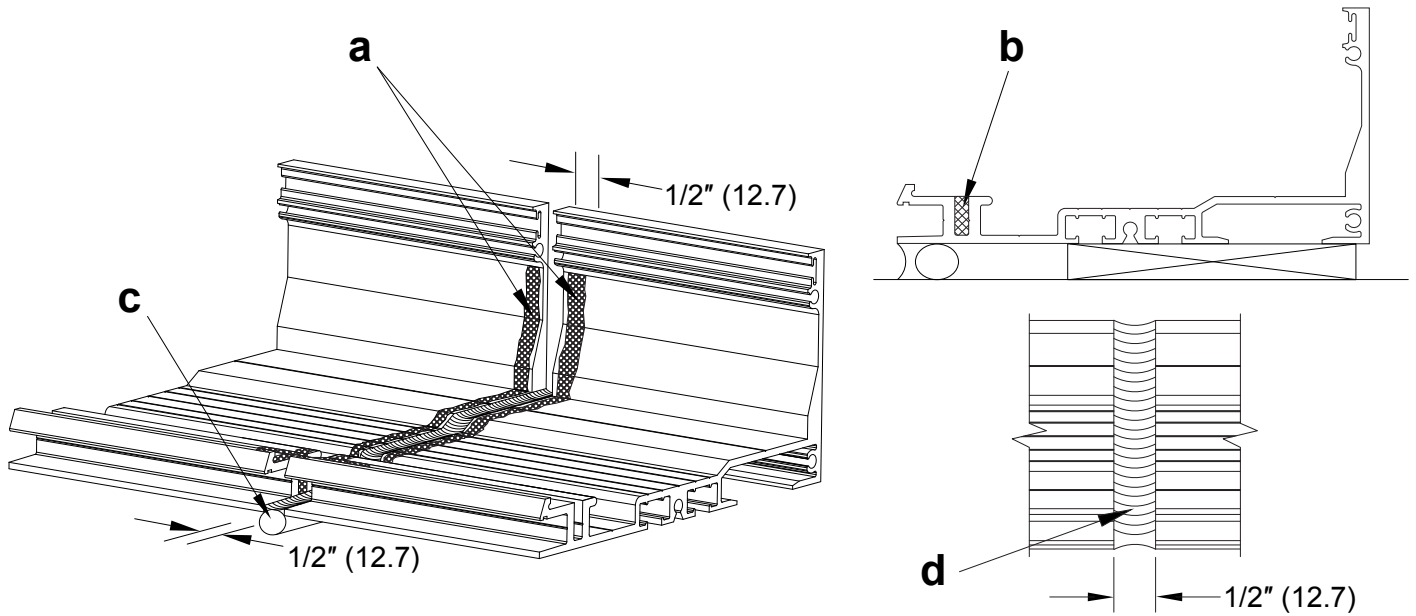

- a. Apply bead of silicone within 1/2" (12.7) of the edge of sill members on each side of 1/2" (12.7) joint.
- b. Fill front screw chase completely with silicone a minimum of 1" (25.4) from cut end of flashing.
- c. Place backer rod between splice in the shim space and seal between splice with silicone.
- d. Apply bead of silicone sealant over backer rod in 1/2" (12.7) joint between flashing.
- e. Tool sealant into joint.

4. Attach splice sleeve.

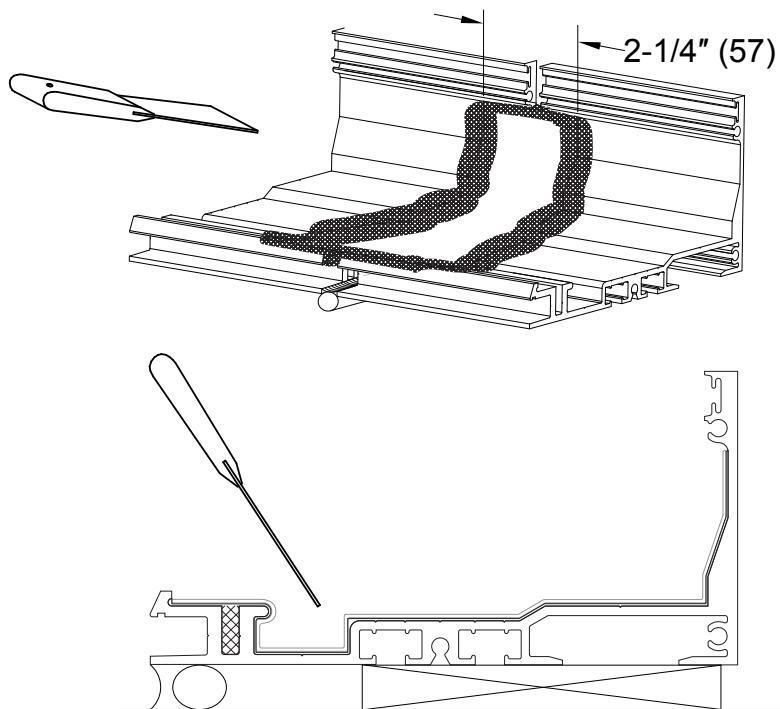

- a. Remove protective liner from 7" (177.8) length of splice sleeve.
- b. Center splice sleeve over joint and bed splice sleeve into sealant.
- c. Use a putty knife to form splice sleeve along flashing profile. Silicone will squeeze out from under the splice sleeve.

**NOTICE**

Do NOT press splice sleeve into screw chase groove at front of flashing.

5. Tool off excess silicone.

**NOTICE**

Tool to prevent or remove build up of sealant at the front and back of splice. Excess sealant may prevent horizontal from sitting correctly over the splice.

6. Seal joint.

- a. Seal back and front of exposed joint and marry into perimeter seals.
- b. Force sealant under front of splice sleeve. Seal exposed joint.

Sill Flashing Installation

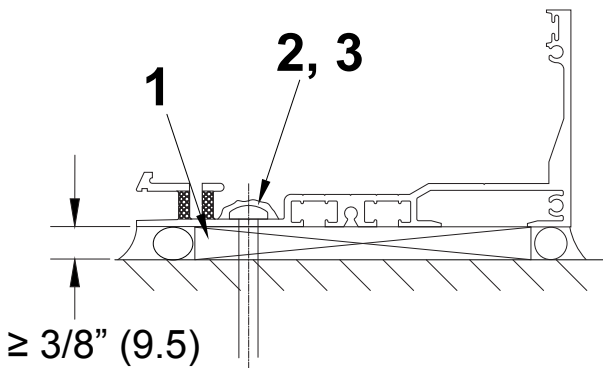

1. Shim sill flashing as needed.
 - a. Shim sill flashing a minimum of $3/8''$ (9.5) as needed at each fastener and under each mullion location.
 - b. Confirm sill flashing is level and true in the opening.
2. Secure sill flashing in opening.
3. Seal over the heads of all sill flashing anchor fasteners.

Sill Flashing at Door Jamb

Exterior

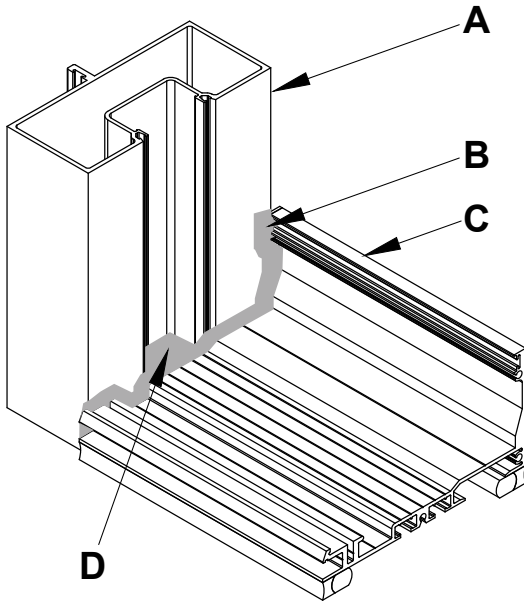

Interior

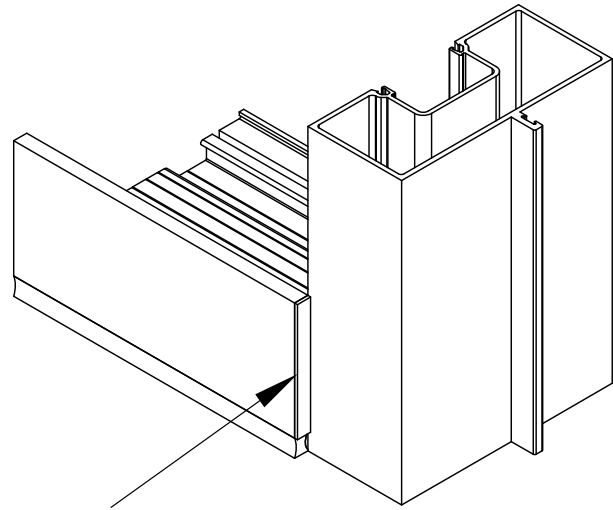

Sill Flashing End Cap

A	Door Jamb
B	Seal sill flashing to door jamb including vertical leg.
C	Sill Flashing
D	Fill glass pocket completely with sealant. Tool sealant to slope into sill flashing.

i NOTICE
Sill flashing end cap is not designed to be water tight, but to provide a backing surface for sealant applied between the sill flashing leg and the door jamb.

Sill Flashing at Corners

Typical 90° Corner Joint

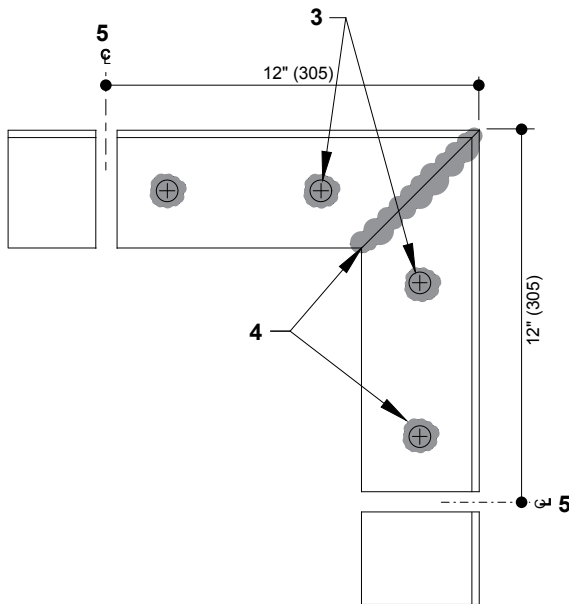

Typical 135° Corner Joint

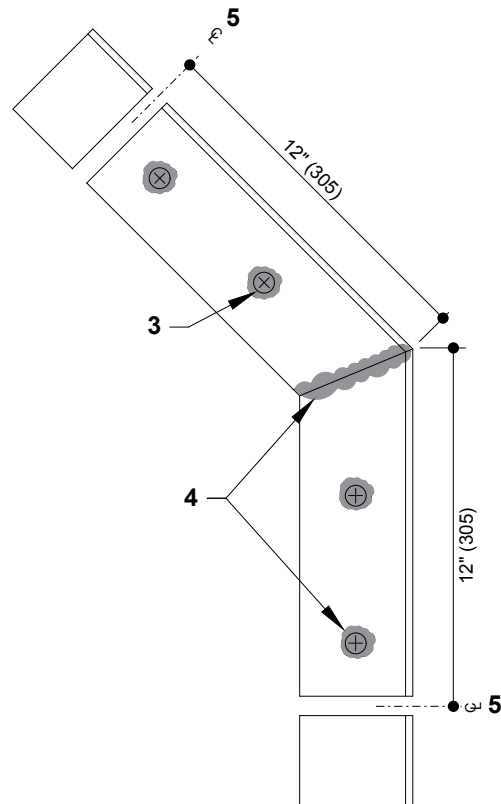

1. Miter two 12" (304.8) sections of sill flashing to correct angle.
2. Set the tight, mitered joint in a bed of sealant and with a tight joint.
3. Securely anchor joint in place.
4. Completely seal *non-moving* mitered joint and anchors.
5. Install splice sleeves with centerlines 12" (304.8) from corner.

Frame Installation

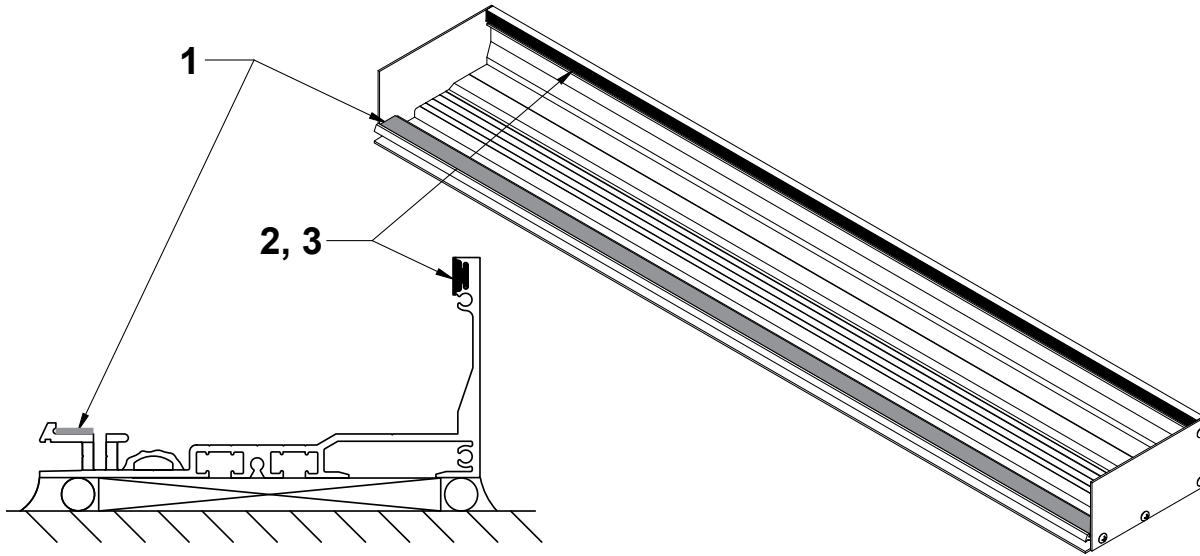

1. Apply a continuous bead of sealant to front ledge of flashing.
2. Check for 127043 weathering in top reglet of sill flashing back leg.
3. If weathering was not installed, then fill reglet with sealant.



NOTICE

When each frame is installed there must be good sealant contact between sill and sill flashing.

- a. Apply a continuous bead of sealant to fill reglet.
 - b. Make sealant bead large enough to sit proud of reglet.
4. Align assembled frame with installed sill flashing.

5. Anchor sill to sill flashing.



NOTE

Refer to Sill to Sill Flashing Anchor Schedule.

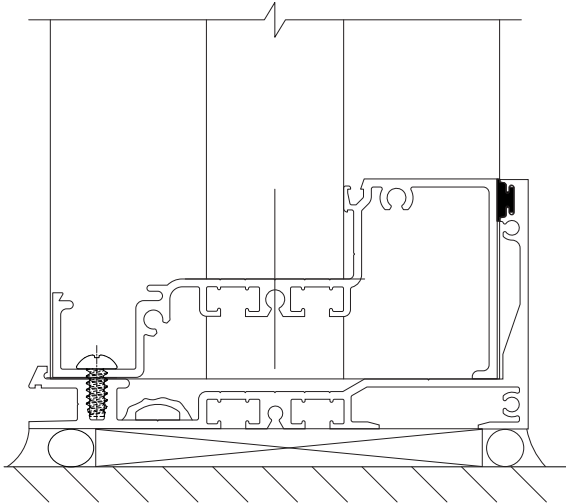

6. Insert shims and anchor as needed at head and jambs.



NOTICE

If heavy mullion or steel reinforcing is used, extra perimeter fasteners may be required to handle larger loads. Consult Area Application Engineering Department.

7. Confirm unit is level and plumb.

8. After installing each frame, tool and clean up sealant.

1. Tool sealant along seam between sill and sill flashing.
2. Remove excess sealant from visible surfaces.

Sill To Sill Flashing Anchor Schedule

Mullion End Reactions	Anchor Locations
≤ 400 lb	One (1) fastener on each side of vertical mullion, located 3" (76.2) from the end of the sill members
> 400 lb and ≤ 800 lb	Two (2) fasteners on each side of vertical mullion, starting 3" (76.2) from the end of the sill member and spaced 2" (50.8) on centers going away from the end
> 800 lb	Three (3) fasteners on each side of vertical mullion, starting 3" (76.2) from the end of the sill member and spaced 2" (50.8) on centers going away from the end

Mullion End Reactions	Anchor Locations
<p>i NOTICE Also locate a minimum of one (1) fastener at the centerline of the DLO with a maximum spacing of 36" (914.4) from adjacent anchors and a maximum 200 lb reaction per fastener.</p>	

Glazing Application	Anchor Fastener
Center and Back Set glazing	128407: #10-16 x 7/16" CRPHTFS-B / 300 Series SS
Front Set glazing in Trifab® VG 450	128582: #10-16 x 1-1/4" CRPHTFS-B / 300 Series SS
Front Set glazing in Trifab® VG 451/451T	128583: #10-16 x 1-3/8" CRPHTFS-B / 300 Series SS

Shim Installation

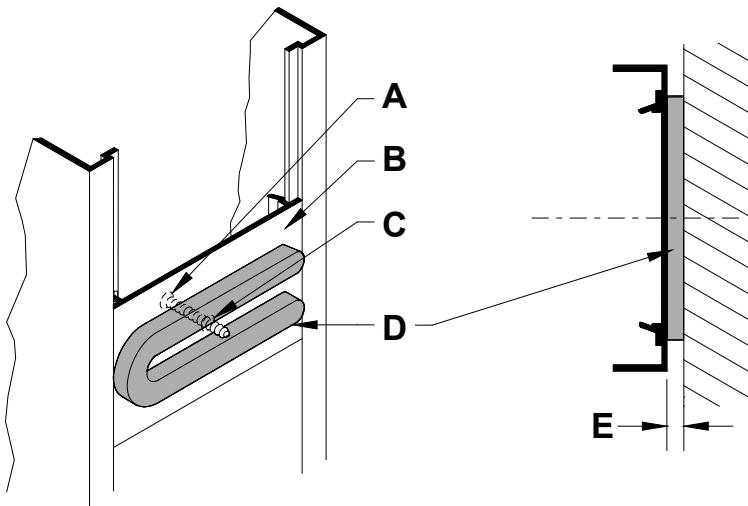

A	Flat head perimeter fastener (not by Kawneer)
B	3" (76.2) long shim filler or pocket filler
C	Clear hole in flat filler lines up with countersunk hole in pocket of perimeter member.
D	Standard horseshoe shim as required (not by Kawneer)
E	Shim 3/8" (9.5) typical

1. Install support shims at head, sill, and jamb.
2. Place between pocket filler and perimeter condition at perimeter anchor locations.

HEAD RECEPTOR

Head Receptor Splice Installation

1. Cut 127178 silicone splice sleeve length to fit the area shown.
2. Apply silicone sealant to lower surface of head receptor. Apply within 3/4" (19.1) of each cut end.
3. Remove the protective liner from splice sleeve.
4. Apply silicone splice sleeve to lower surface of head receptor.
 - a. Center sleeve over the splice joint.
 - b. Bed splice sleeve in the sealant.
 - c. Use a putty knife to form sleeve around the profile.
5. Apply silicone sealant to top surface of head receptor. Apply within 3/4" (19.1) of each cut end.
6. Cut 127178 silicone splice sleeve length to 2-1/4" (57.2) x 1-3/4" (44.5).
7. Remove the protective liner from splice sleeve.
8. Apply silicone splice sleeve to top surface of head receptor.
 - a. Center sleeve over the splice joint.
 - b. Bed splice sleeve in the sealant.
 - c. Use a putty knife to tool sleeve smooth.

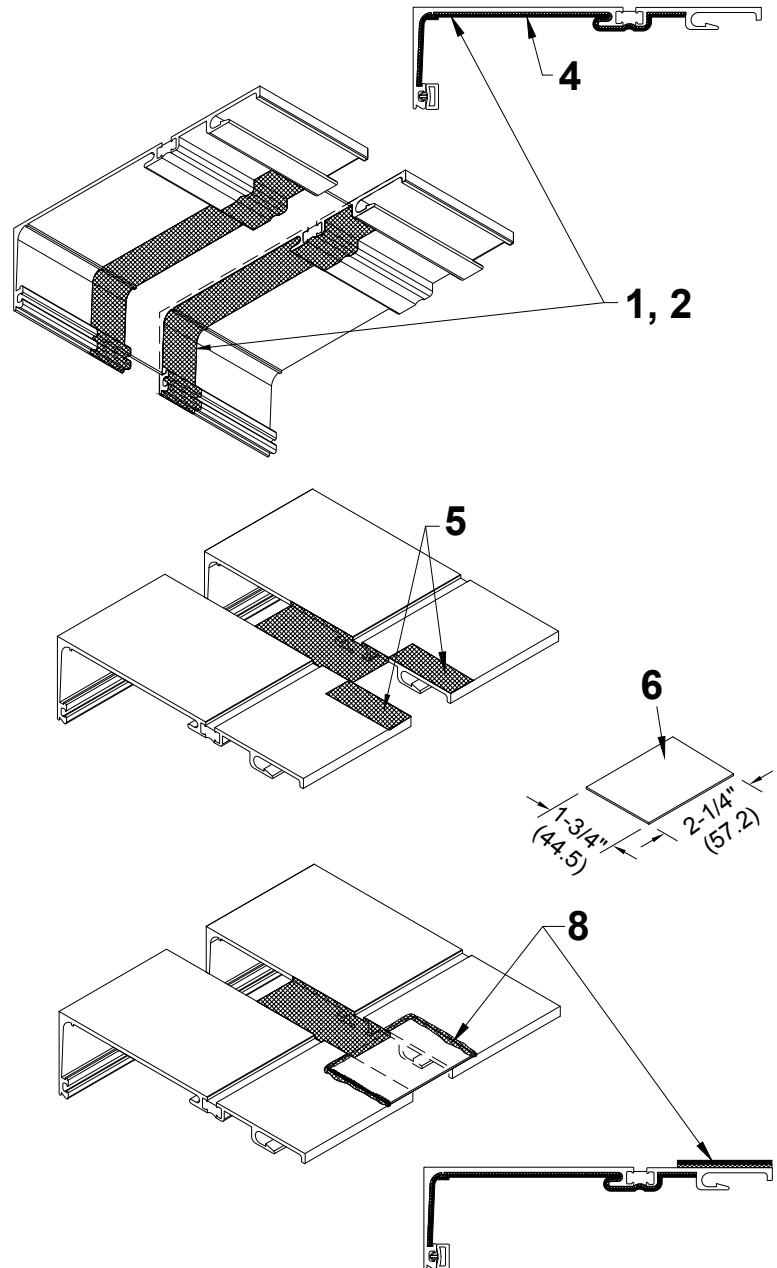

Head Receptor Installation

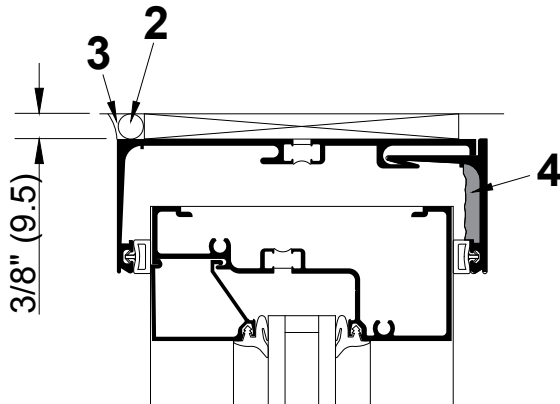

1. Install head receptor with a 3/8" (9.5) space at the head.
2. Place a backer rod on the exterior side as shown.
3. Fill the gap with silicone sealant.
4. Fully seal end by applying silicone inside head receptor face.

Head Receptor End Dam Placement

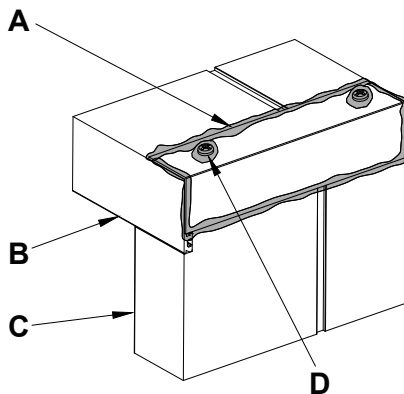

A	601CG317: Receptor Corner End Dam
B	Head Receptor
C	Jamb Receptor
D	028808 fasteners

1. Liberally apply silicone sealant where end dam will be placed.
2. Push end dam firmly onto sealed surfaces, evenly spreading the sealant.
3. Install two (2) 028808 fasteners and seal over the heads.
4. Tool silicone around all edges to seal well.

Head Receptor Silicone Sealant

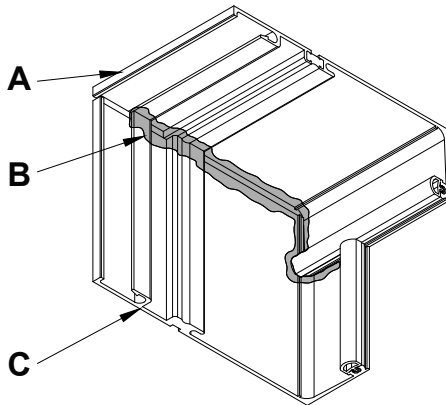

A	Head Receptor
B	Fill extrusion joint with silicone sealant.
C	Jamb Receptor

1. Liberally apply silicone sealant along the inside corner.
2. Confirm that any gaps in the extrusion joint are filled.
3. Tool silicone to seal well.

Jamb Receptor And Sill Flashing Joints

With Removable Face On Exterior

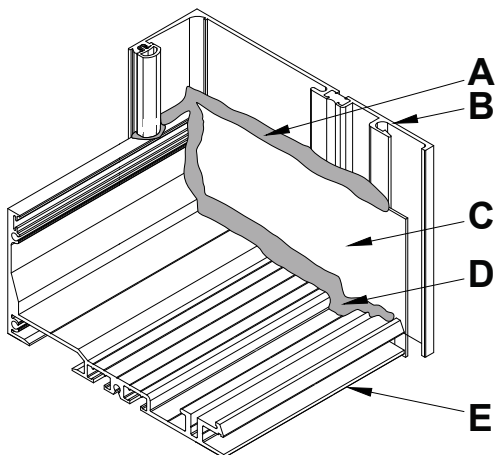

With Removable Face On Interior

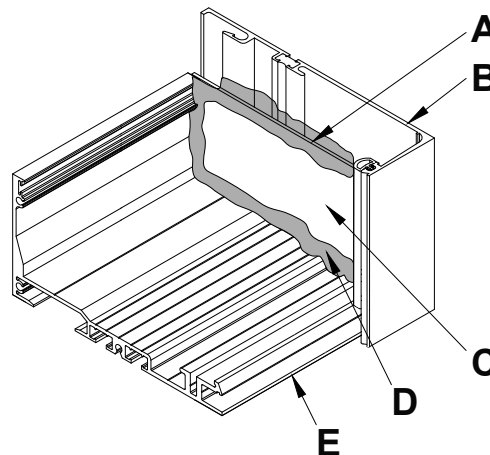

A	Backer Rod Installed Between End Dam and Jamb Receptor
B	Jamb Receptor
C	End Dam
D	Fill extrusion joint with silicone sealant.
E	Sill Flashing

1. Install backer rod in opening between end dam and jamb receptor.
2. Liberally apply silicone sealant along the inside corner.
3. Confirm that any gaps in the extrusion joint are filled.
4. Tool silicone to seal well.
5. Apply silicone in the receptor face snap in pocket before final assembly.

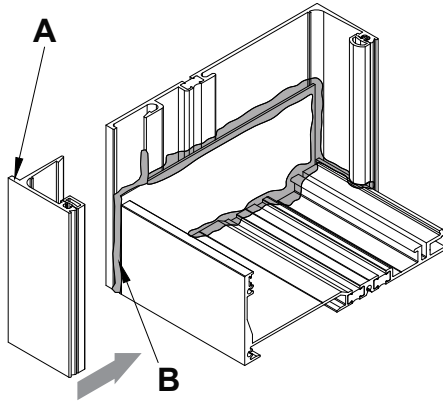

A	Receptor Face
B	Silicone in receptor face snap in pocket

Install Water Deflector



NOTICE: COLD WEATHER INSTALLATION

For temperatures below 40°, prepare aluminum surfaces just prior to installing. Wipe with a solvent or cleaning solution recommended by the sealant manufacturer to remove any condensation or frost.



REFER TO SAFETY DATA SHEET (SDS)

Carefully follow recommendations contained in the safety data sheet (SDS) provided by the solvent/cleaning solution manufacturer regarding health and fire/explosion risks.

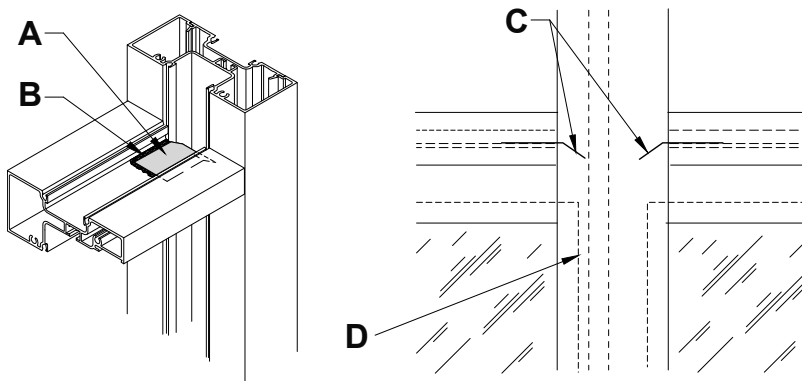

A	Water Deflector
B	Sealant
C	Extend water deflectors past glass edge.
D	Edge of Glass

1. Remove paper backing from water deflector.
2. *For thermal horizontal members*, fill cavity under deflector with sealant.
3. Locate water deflector centered in glazing pocket and extending past glass edge.
4. Fix deflector to clean, dry surface of horizontal.
5. Apply sealant around edges of deflector.

6. Seal joint between back leg of horizontal and the vertical.

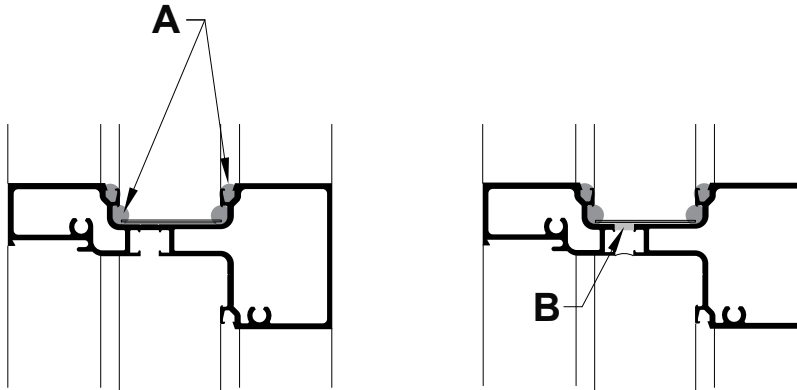

Non-thermal Horizontal

Thermal Horizontal

A	Sealant
B	For thermal members, seal cavity under deflector.



NOTICE

Confirm that glazing reglets in the area of this joint are filled. Failure to fill these reglets will allow water to reach the lite below.

GLAZING

Install Glazing Adapters for Trifab® VersaGlaze® 451/451T

Installation Prior to Frame Assembly

Vertical glazing adapters may be installed for either partial or full-length applications at the time frames are assembled.

1/4" over 1"

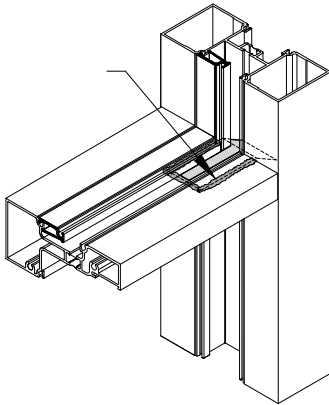

1" Water Deflector for Partial Length Application

1/4" over 1/4"

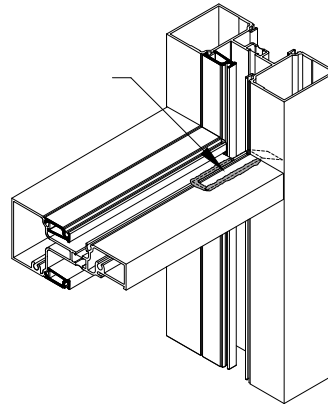

1/4" Water Deflector for Full Length Application



NOTICE

When using pre-installed vertical glazing adapters, seal the vertical glazing reglets where they meet the intermediate horizontals at the time of frame assembly. Use 1/4" water deflector on all full-length applications and install as instructed. Use 1" water deflectors on partial adapter applications as long as the adapter does not impede water evacuation of the intermediate horizontal. The water deflector must allow water to drain into the vertical pocket beyond the edge of the glass below.

1. Cut glazing adapters.

	Partial Length Application	Full Length Application
Vertical Adapters	DLO + 1/2" (12.7)	Vertical Member Length
Horizontal Adapters	DLO	

2. Install vertical adapters.

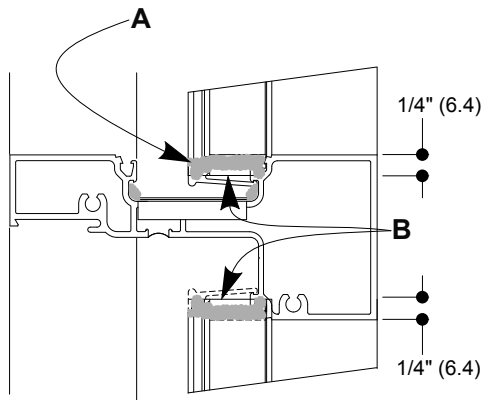

A	Sealant at End of Horizontal Adapter
B	Line of Horizontal Adapter

- a. Snap vertical adapters into glazing reglets of frame.
 - b. Assemble frame as instructed.
 - c. Position vertical adapter
 - such to allow sealing of horizontal adapter to vertical,
 - with approximately 1/4" (6.4) projection into horizontal pocket,
 - d. If needed, lightly crimp vertical adapter in place to prevent sliding.
3. Seal the vertical glazing reglets where they meet the intermediate horizontals.
 4. Apply sealant to vertical adapter at final position of snapped-in horizontal adapter.

5. Install horizontal adapters.

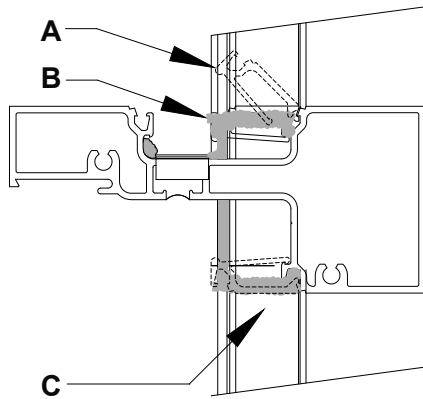

A	Rotate Adapter
B	Sealant at End
C	Adapter Runs Length of Vertical

- a. Snap horizontal glazing adapter into the glazing reglet.
- b. Ensure adapter rotates into pocket and contacts sealant at vertical adapter.

Installation After Frame Assembly and For Field Retrofit Applications

1. Cut vertical glazing adapters to DLO + 1/2" (12.7).
2. Notch at each end of the vertical glazing adapter.

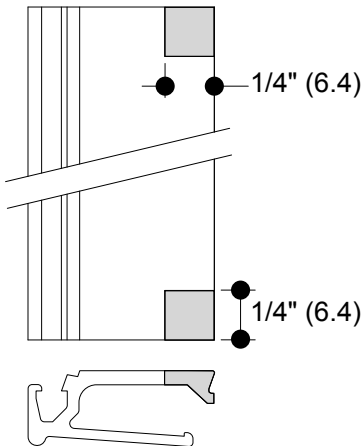

- Cut notch on face side of adapter nearest the gasket reglet.
 - Cut notch to 1/4" (6.4) x 1/4" (6.4).
3. Cut horizontal glazing adapters to DLO.

4. Install vertical adapters.

**NOTICE**

Ensure that the glazing adapter does not impede water evacuation of the intermediate horizontal. The previously installed 1" water deflector must allow water to drain into the vertical pocket beyond the edge of the glass below.

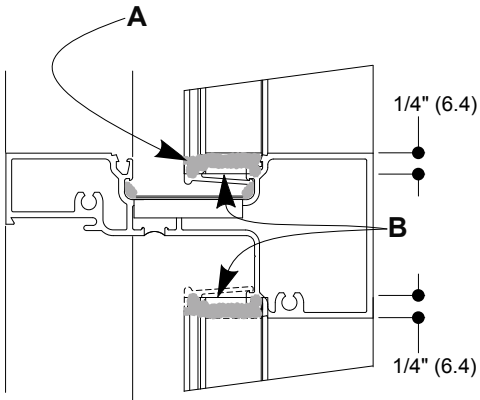

A	Sealant at End of Horizontal Adapter
B	Line of Horizontal Adapter

a. Position vertical adapter

- such to allow sealing of horizontal adapter to vertical,
- with approximately 1/4" (6.4) projection into horizontal pocket,

b. Snap vertical adapters into glazing reglets of frame.

5. Apply sealant to vertical adapter at final position of snapped-in horizontal adapter.

6. Install horizontal adapters.

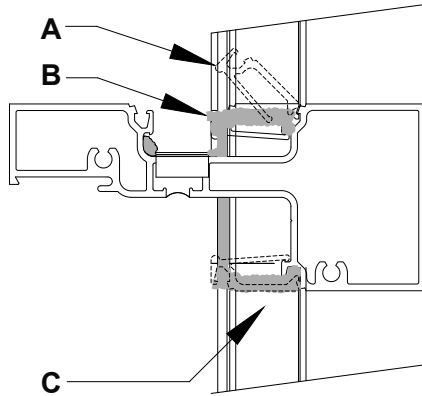

A	Rotate Adapter
B	Sealant at End
C	Adapter Runs Length of Vertical

- a. Snap horizontal glazing adapter into the glazing reglet.
- b. Ensure adapter rotates into pocket and contacts sealant at vertical adapter.

Glazing Charts



IMPORTANT

1. Pocket sizes:

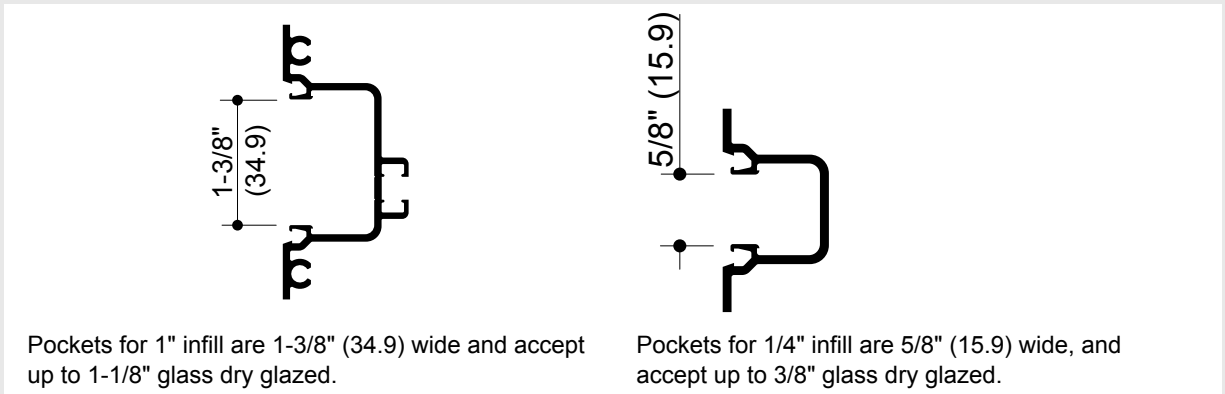

2. Glass size = Daylight Opening (DLO) + 3/4" (19.1). *This formula does not allow for undersize or out of square daylight openings.*

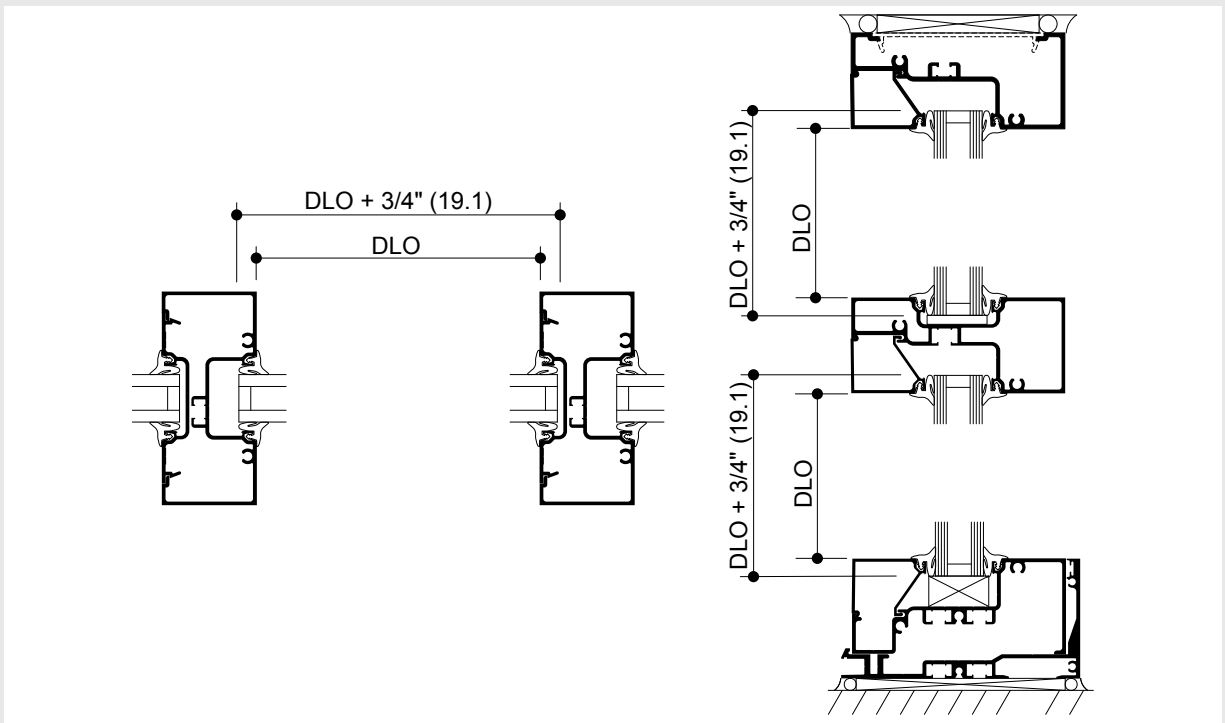

3. See Dart Corner sections for dart corner glass sizes.
4. The glass manufacturer must indicate the specific glazing requirements for the material being used.

Glazing Chart for 1/4" System

Infill Thickness	*Weathering (Both Sides)
1/8"	027077 (Heavy)
1/4"	027074 (Standard)
3/8"	027076 (Light)

Glazing Chart for 1" System

Infill Thickness	**Adapter	*Weathering (Both Sides)
1/8"	451VG029	027077 (Heavy)
1/4"	451VG029	027074 (Standard)
3/8"	451VG029	027076 (Light)
1/2"	451VG030	027077 (Heavy)
5/8"	451VG030	027074 (Standard)
3/4"	451VG030	027076 (Light)
7/8"	-----	027077 (Heavy)
1"	-----	027074 (Standard)
1-1/8"	-----	027076 (Light)



GLAZING CHART NOTES

* For infill thickness in 1/16" increments or oversize and undersize glass, use a combination of the standard with either the light or heavy gaskets.

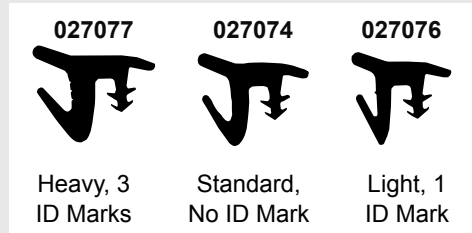

** Snap-in glazing adapters 451VG029 and 451VG030 are provided for application requiring infills less than 1" thickness at adapter. Reference Section VIII, Glazing Adapters for adapter cut lengths and seal information.

"W" Side Block Installation

"W" side blocks prevent glass from shifting into the deep pocket. Install one "W" side block in the mullion deep pocket of each lite of glass in an opening.

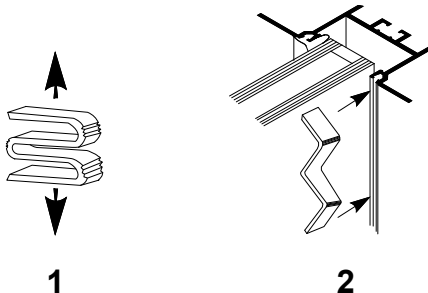

1. Stretch and flatten block.
2. Slide "W" block between reglet and glass lite. Block will return to original shape and wedge between walls of glazing pocket

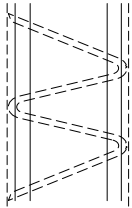
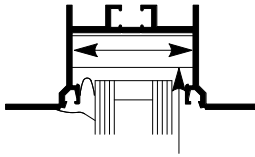
**TIP**

If deglazing of lite is required after "W" block is installed, remove both interior and exterior weathering and use hook to pull "W" block out of pocket.

Gasket and Glass Stop Installation

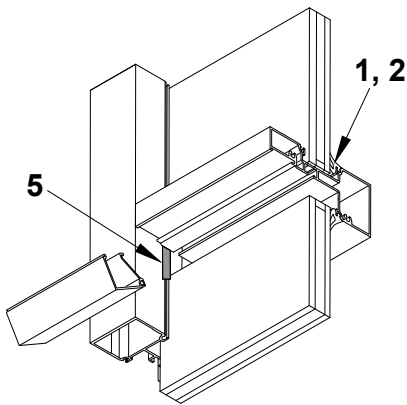

1. Cut horizontal and vertical gaskets to approximate length, $L_{gasket} = DLO + (DLO/48)$.

2. Install gaskets on frame side opposite glass stops.

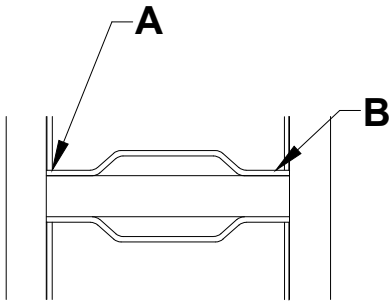

A	Vertical gaskets run between horizontal gaskets.
B	Start at ends and work toward the center.

- a. Insert gasket into the horizontal members first.
 - b. Start at ends and work toward the center.
 - c. Insert vertical gasket on same side in the same manner.
3. Position setting blocks under glass at required points
 4. Install glass into frame using standard flush glazing technique.
 5. Run bead of sealant along vertical reglets where glass stop meets.
 6. Install glass stop.
 7. Install horizontal and vertical gasket into glass stop side of frame as in step 2.

OPTIONAL CORNERS

Adjustable Corners

Use the same preps as required for the standard vertical.

Aluminum Brake Metal Set in Sealant

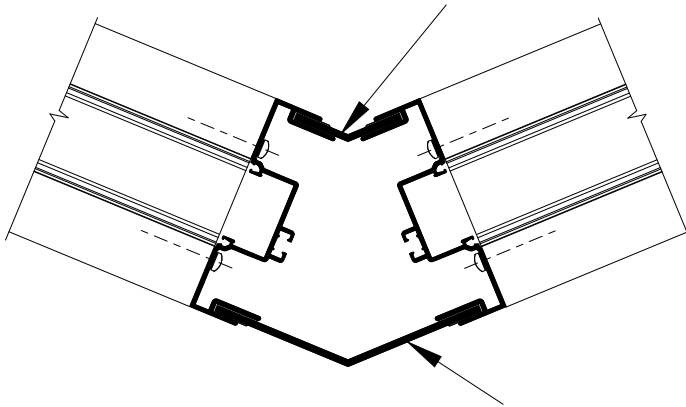

Pivoted Inside and Outside 155° to 180° Corners

Use the same fabrication methods as required for the standard vertical.



NOTE

Layout and cut sizes can be determined using pivot center lines. Corner parts and fabrication are the same when flipped for outside corners.

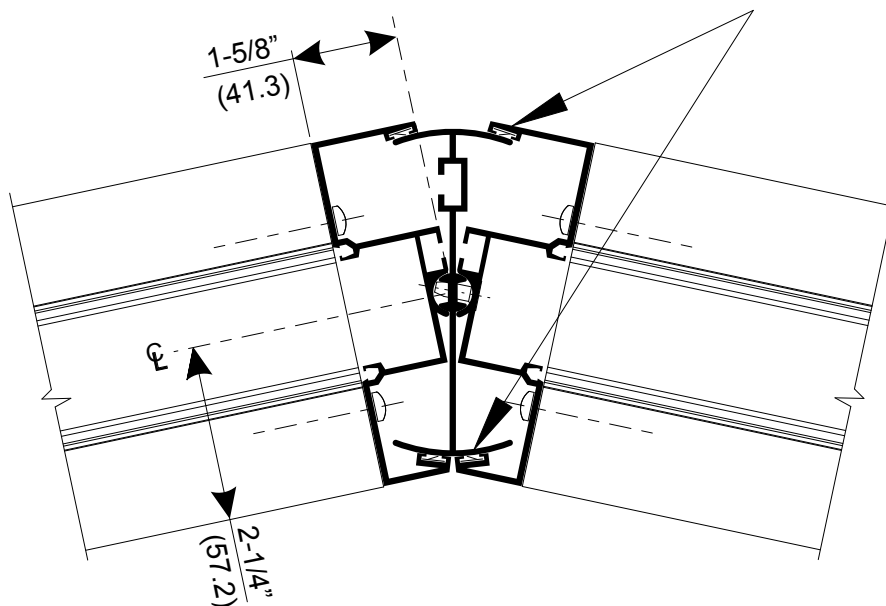

Continuous weathering installed into both corner halves before assembly (4) places.

1. Locate screw holes 6" (152.4) from each end and 24" (609.6) on center.
2. Drill (#26) and countersink 0.147 diameter holes for assembly screws (#10 x 9/16").
3. Fasten with supplied screws.

Snap Corners



NOTICE

Corners are not designed to be unsnapped.



TIP

Wax tight snaps to make engagement easier.

Snap corners together as shown.

90° Corner

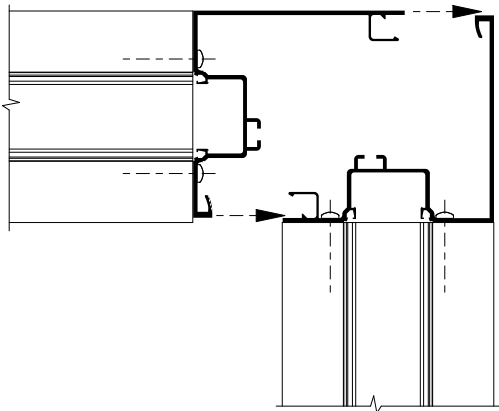

135° Corner

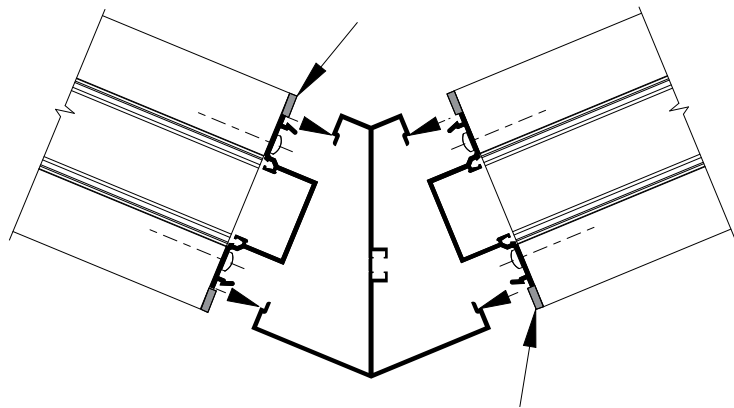

Sealant Locations

90° Dart Corners

1. Cut mullion halves and cover to required length (Frame Height).
2. Cut horizontal to length = daylight opening (DLO).
Miter as shown in following illustrations.
3. Cut glass stops to length = DLO - 1/16" (1.6).
Miter inside glaze glass stop as shown in following illustrations.
4. Drill mullion halves for shear blocks as shown in following illustrations, using the fabricated clip as a template.
5. Attach shear blocks using two (2) #028400 (#10 x 1-19/32") pan head screws.
6. Fabricate horizontals for one (1) #128345 (#10 x 9/16") flat head screw as shown in following illustrations.

7. Before installing cover, install 250299 glazing clips into verticals.

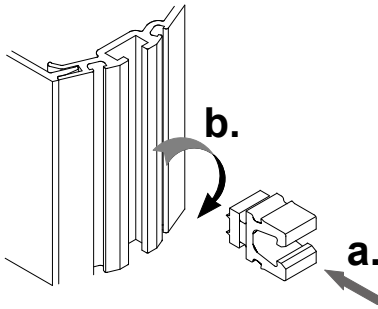

- a. Locate clips no more than 9" (228.6) O.C. and no more than 3" (76.2) from the ends of mullions.
- b. Push clip (250299) into mullion reglet.
- c. Twist clip 1/4 turn clockwise to lock in place.

Trifab® VersaGlaze® 450

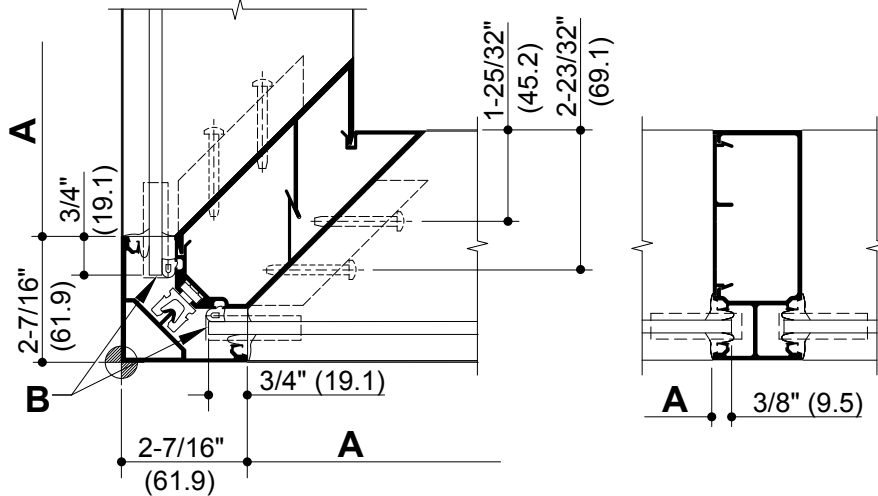

A	DLO
B	Extend water deflector past glass edge below.
Glass Formula: DLO + 1.125" (28.6)	

Trifab® VersaGlaze® 451/451T

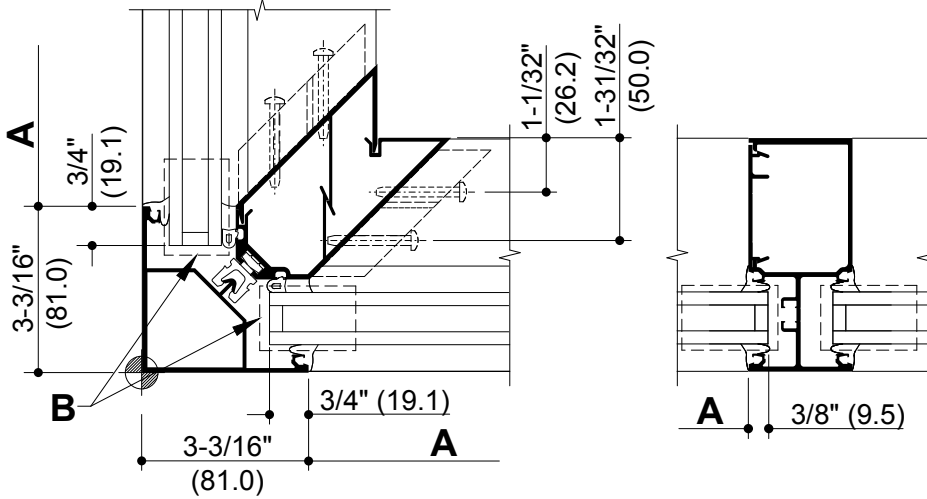

A	DLO
B	Extend water deflector past glass edge below.
Glass Formula: DLO + 1.125" (28.6)	

90° Dart Corners for Trifab® VersaGlaze® 450

Inside Glazed Head

Outside Glazed Head

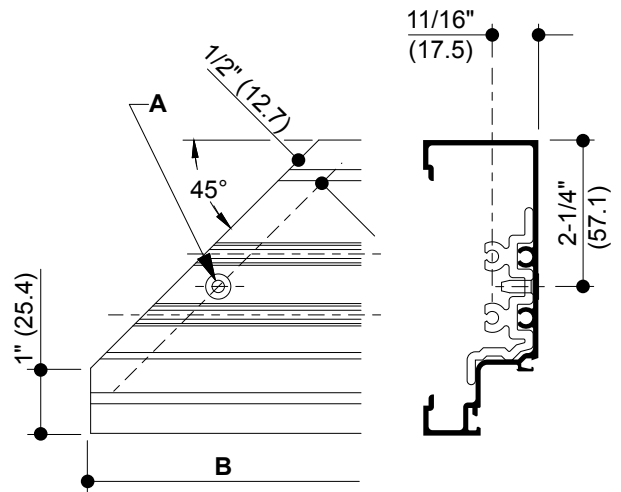
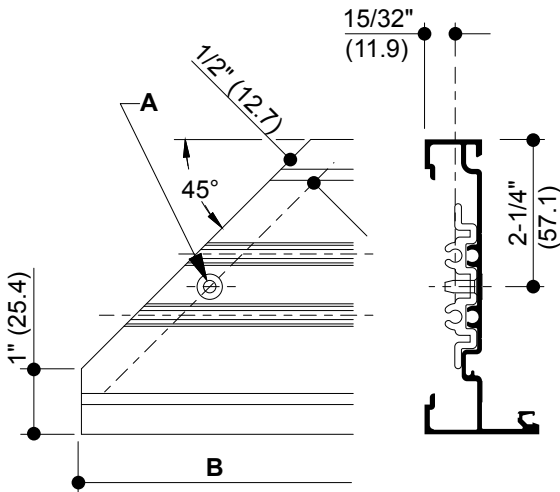

A	0.201" dia. hole (#7 drill); 0.390" dia. x 82° countersink
B	DLO
Cut Length = DLO	

Inside Glazed Horizontal

Outside Glazed Horizontal

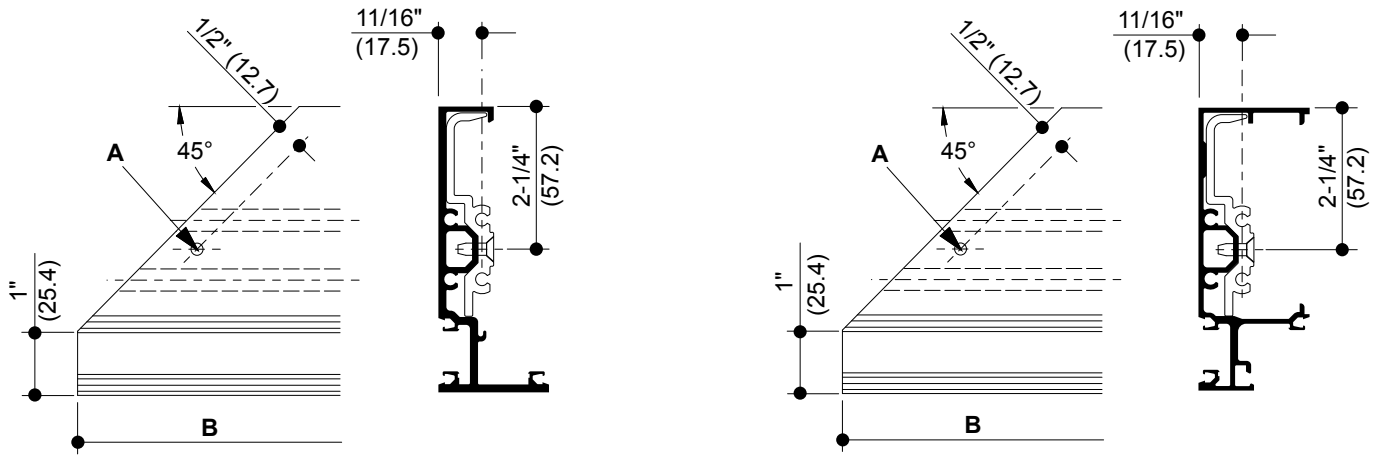

A	0.147" dia. hole (#26 drill)
B	DLO
Cut Length = DLO	

Inside Glazed Glass Stop

Inside or Outside Glazed Sill

Outside Glazed Glass Stop

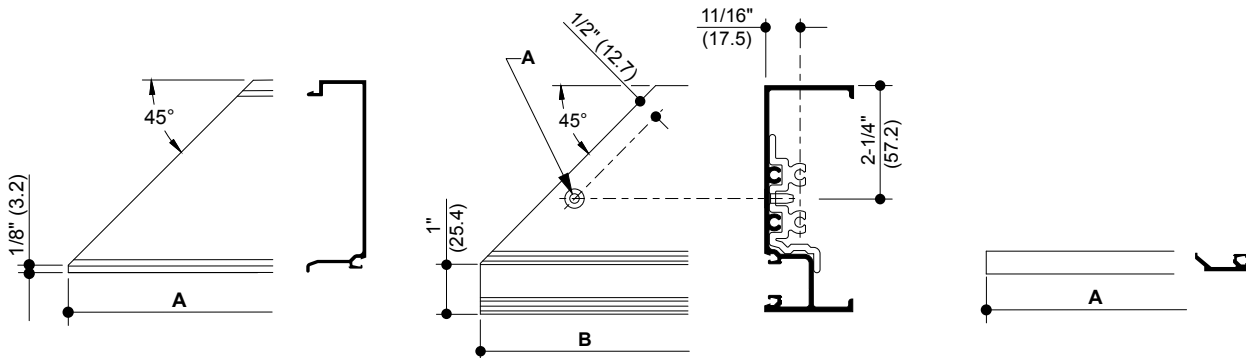

A	DLO
Cut Length = DLO - 1/16" (1.6)	

A	0.201" dia. hole (#7 drill); 0.390" dia. x 82° countersink
B	DLO
Cut Length = DLO	

A	DLO
Cut Length = DLO - 1/16" (1.6)	

90° Dart Corners for Trifab® VersaGlaze® 451/451T

Inside Glazed Head

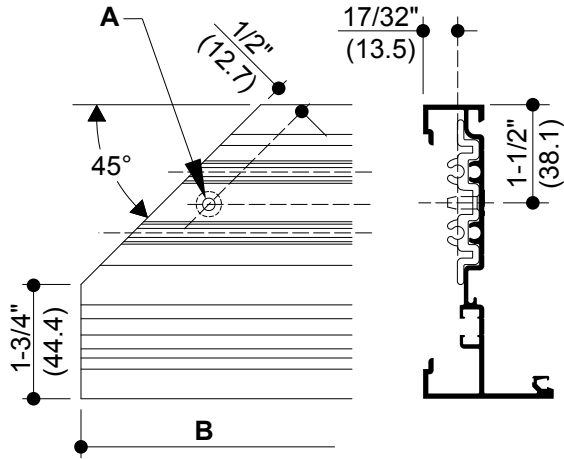

Outside Glazed Head

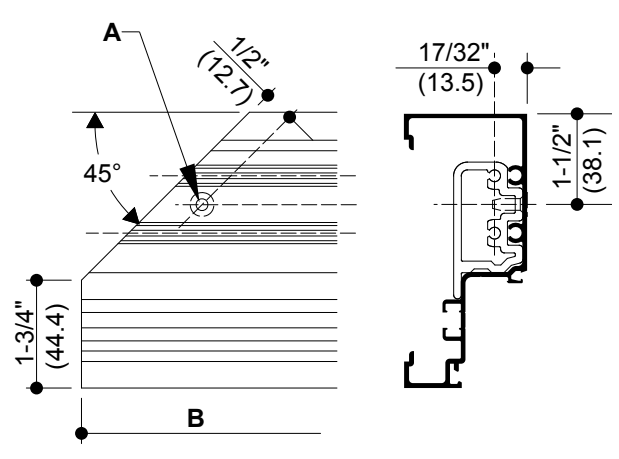

A	0.201" dia. hole (#7 drill); 0.390" dia. x 82° countersink
B	DLO
Cut Length = DLO	

Inside Glazed Horizontal

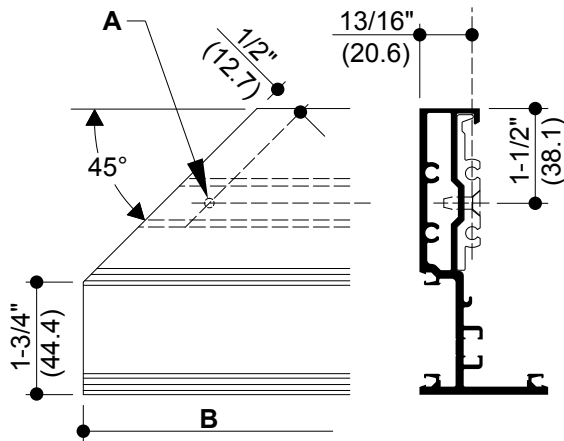

Outside Glazed Horizontal

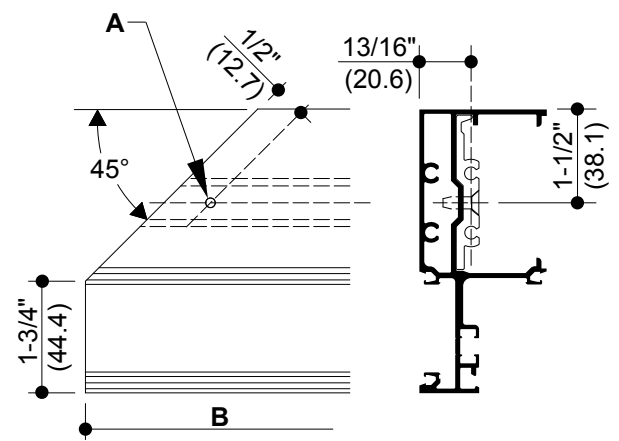

A	0.147" dia. hole (#26 drill)
B	DLO
Cut Length = DLO	

Inside Glazed Glass Stop

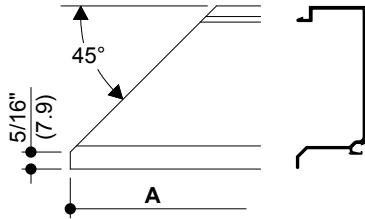

Inside or Outside Glazed Sill

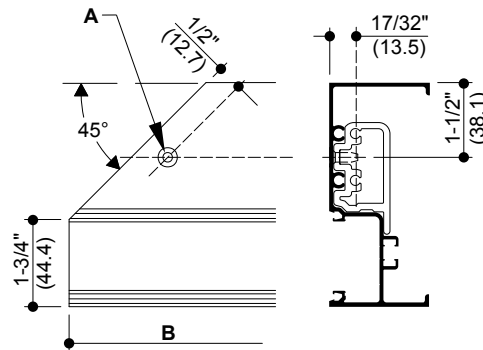

Outside Glazed Glass Stop

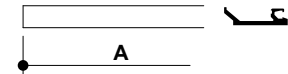

A	DLO
Cut Length = DLO - 1/16" (1.6)	

A	0.201" dia. hole (#7 drill); 0.390" dia. x 82° countersink
B	DLO
Cut Length = DLO	

A	DLO
Cut Length = DLO - 1/16" (1.6)	

135° Dart Corners

1. Cut mullion halves and cover to required length (Frame Height).
2. Cut horizontal to length = daylight opening (DLO).
Miter as shown in following illustrations.
3. Cut glass stops to length = DLO - 1/16" (1.6).
Miter inside glaze glass stop as shown in following illustrations.
4. Drill mullion halves for shear blocks as shown in following illustrations, using the fabricated clip as a template.
5. Attach shear blocks using two (2) #028400 (#10 x 1-19/32") pan head screws.
6. Fabricate horizontals for one (1) #128345 (#10 x 9/16") flat head screw as shown in following illustrations.

7. Before installing cover, install 250299 glazing clips into verticals.

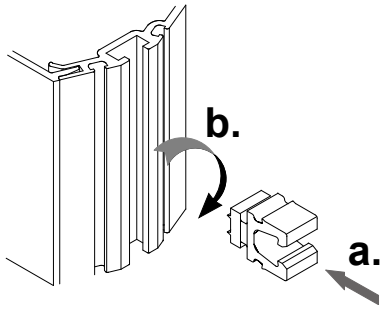

- a. Locate clips no more than 9" (228.6) O.C. and no more than 3" (76.2) from the ends of mullions.
- b. Push clip (250299) into mullion reglet.
- c. Twist clip 1/4 turn clockwise to lock in place.

Trifab® VersaGlaze® 450

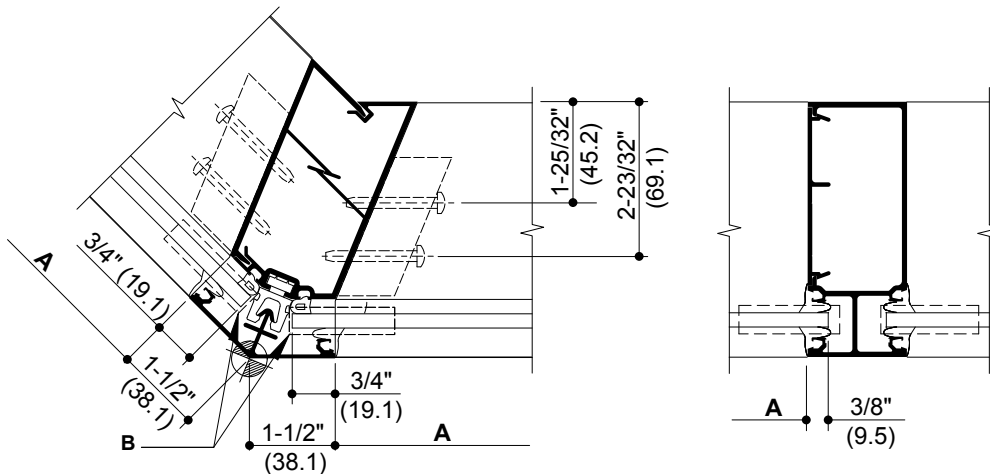

A	DLO
B	Extend water deflector past glass edge below.
Glass Formula: DLO + 1.125" (28.6)	

Trifab® VersaGlaze® 451/451T

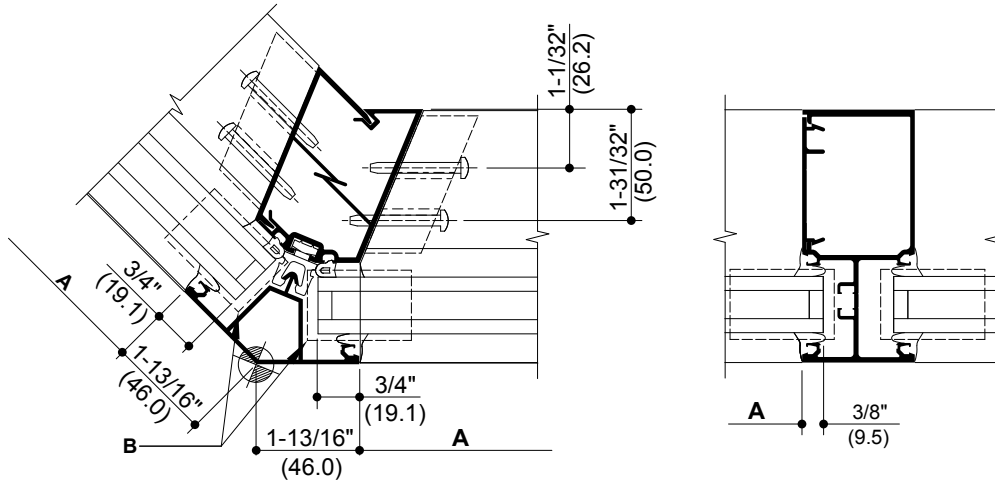

A	DLO
B	Extend water deflector past glass edge below.
Glass Formula: DLO + 1.125" (28.6)	

135° Dart Corners for Trifab® VersaGlaze® 450

Inside Glazed Head

Outside Glazed Head

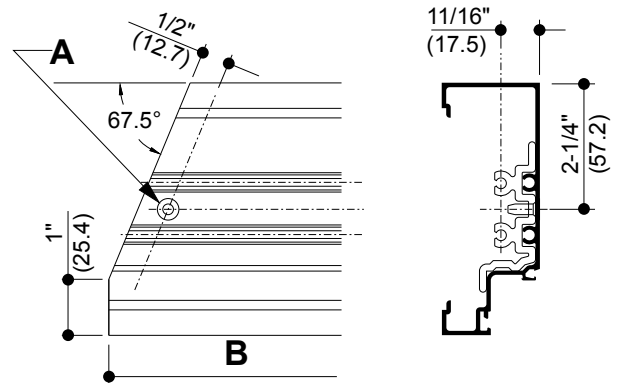
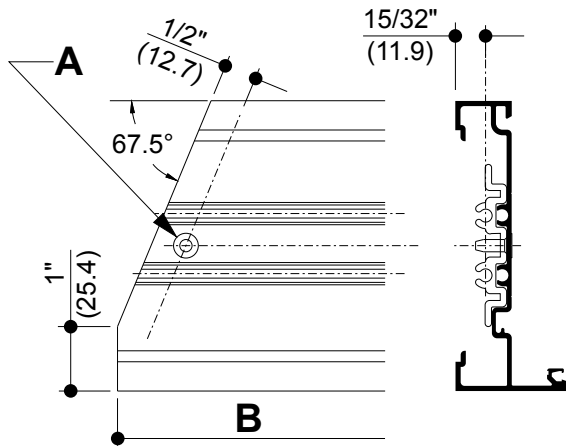

A	0.201" dia. hole (#7 drill); 0.390" dia. x 82° countersink
B	DLO
Cut Length = DLO	

Inside Glazed Horizontal

Outside Glazed Horizontal

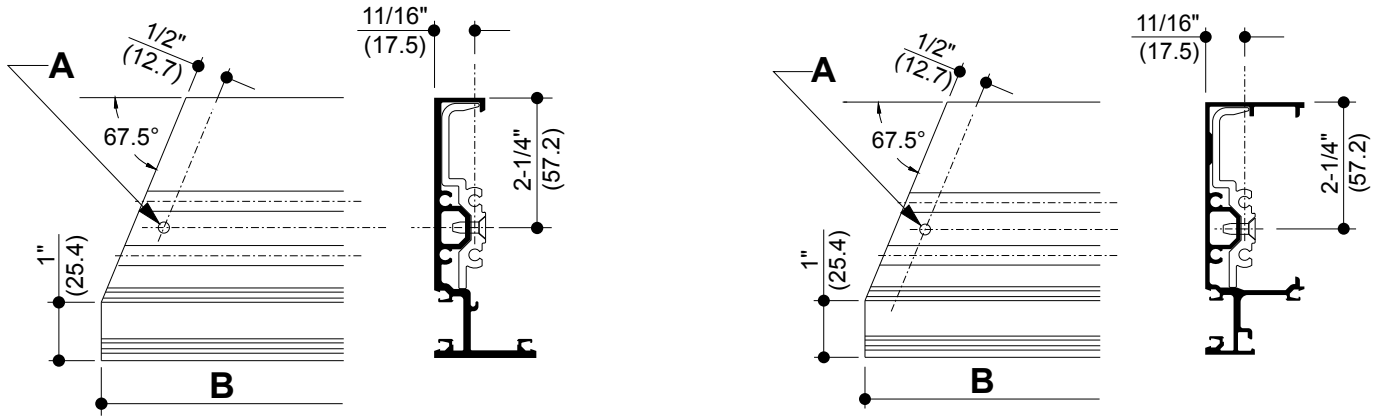

A	0.147" dia. hole (#26 drill)
B	DLO
Cut Length = DLO	

Inside Glazed Glass Stop

Inside or Outside Glazed Sill

Outside Glazed Glass Stop

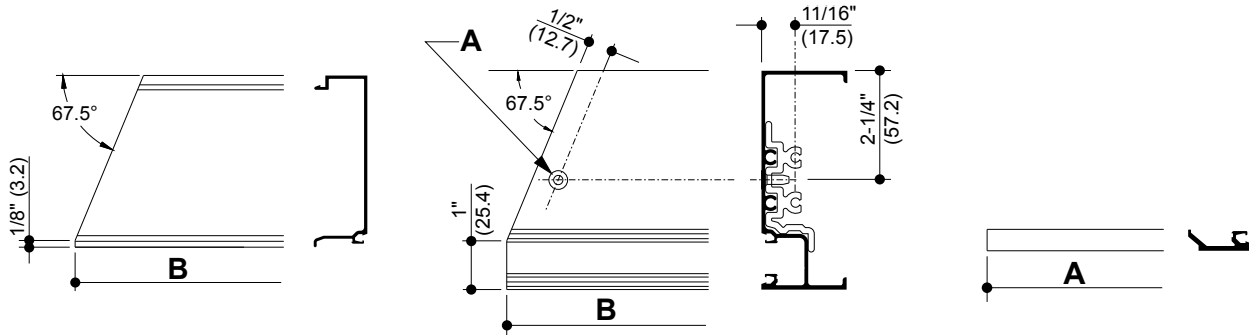

A	DLO
Cut Length = DLO - 1/16" (1.6)	

A	0.201" dia. hole (#7 drill); 0.390" dia. x 82° countersink
B	DLO
Cut Length = DLO	

A	DLO
Cut Length = DLO - 1/16" (1.6)	

135° Dart Corners for Trifab® VersaGlaze® 451/451T

Inside Glazed Head

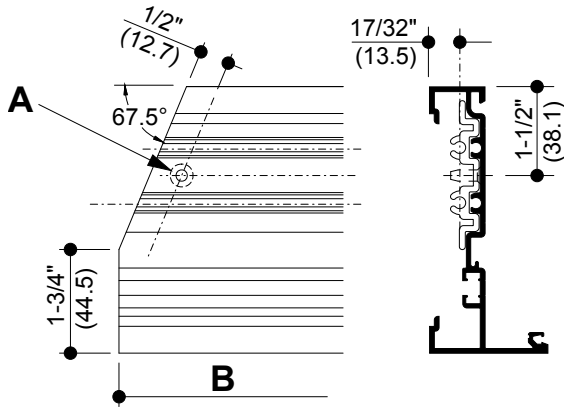

Outside Glazed Head

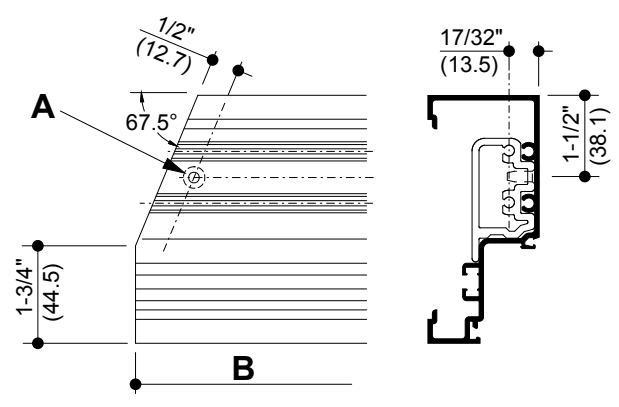

A	0.201" dia. hole (#7 drill); 0.390" dia. x 82° countersink
B	DLO
Cut Length = DLO	

Inside Glazed Horizontal

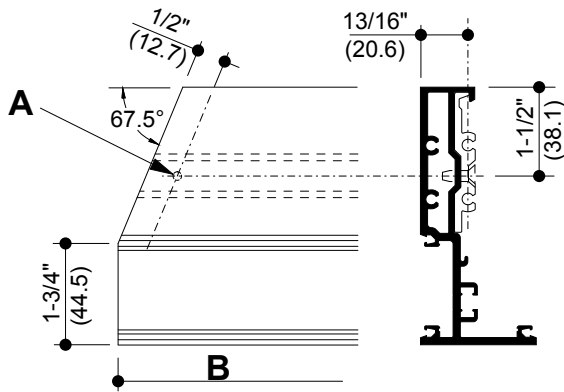

Outside Glazed Horizontal

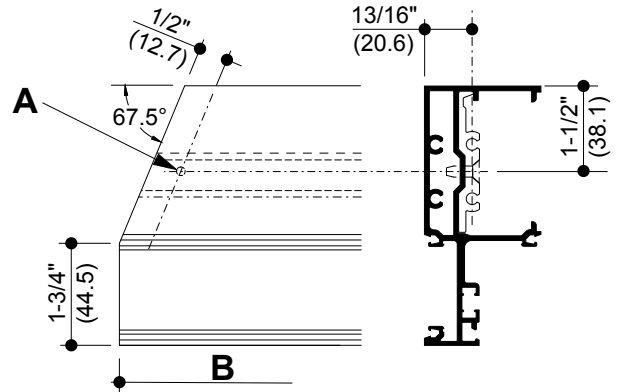

A	0.147" dia. hole (#26 drill)
B	DLO
Cut Length = DLO	

Inside Glazed Glass Stop

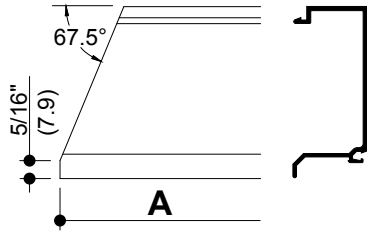

Inside or Outside Glazed Sill

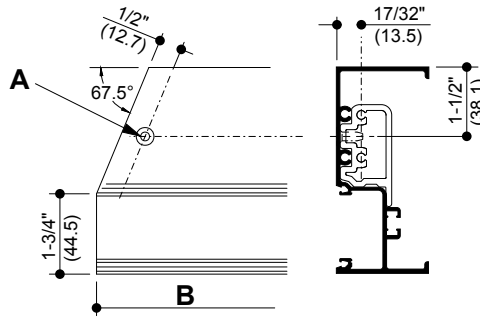

Outside Glazed Glass Stop

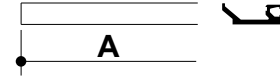

A	DLO
Cut Length = DLO - 1/16" (1.6)	

A	0.201" dia. hole (#7 drill); 0.390" dia. x 82° countersink
B	DLO
Cut Length = DLO	

A	DLO
Cut Length = DLO - 1/16" (1.6)	

Expansion Mullion

Use an expansion mullion every 20' (6.10 m) in large openings, regardless of construction method.

Adjust the dimension of the assembly based on temperature at the time of assembly and expected high and low service temperatures. (For examples, reduce the sight line slightly when installed in hot weather and increase the sight line slightly when installed in cold weather).

Reference Dimensions

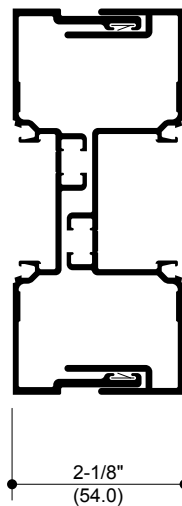
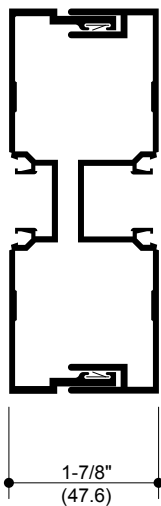

Steel Reinforcing

1. Coat cut ends of steel reinforcing with a corrosion-inhibiting primer before installing.
2. Extend steel reinforcing the full length of the mullion.
3. Shim or fasten steel reinforcement in place to prevent movement of steel in mullion.



NOTICE

For Trifab® VersaGlaze® 451 center plane applications where steel reinforcing is required, you must use the non-thermal split mullion without thermal pockets.

Split Mullion with 450110 Steel Reinforcing

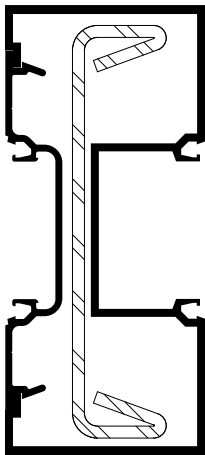

Adjustable Narrow Sidelite Base

For Center Glazed Option Using Non-Thermal, 2-Piece Vertical Only



NOTICE

Project wind loads may produce end load reactions at vertical mullions that may require additional anchors. Consult Application Engineering for review of narrow sidelite base applications.

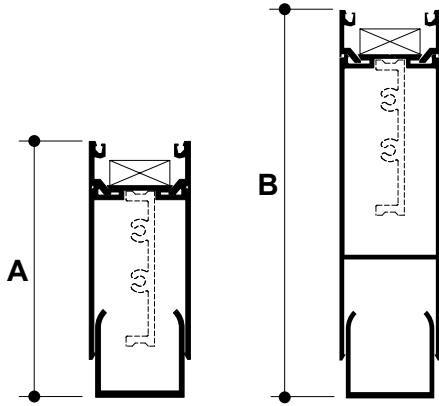

A	5-3/4" (146.1) max. to 4-1/4" (108.0) min.
B	8-3/8" (212.7) max. to 7-1/8" (181.0) min.

1. Determine required sidelite base height.

Standard Base Door	Bottom Rail Height
190 Door with Threshold	5-1/16"
190 Door without Threshold	4-9/16"

Tall Base Door	Bottom Rail Height
350/500 Door with Threshold	5-1/16"
350/500 Door without Threshold	4-9/16"

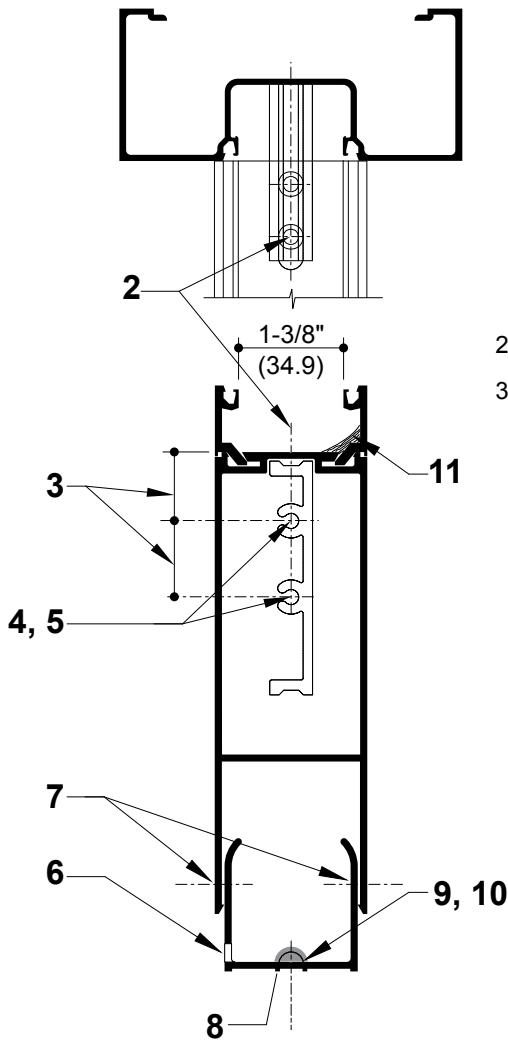

2. Drill top of rail with #26 drill and countersink.
3. Orient clip as needed and center in pocket.

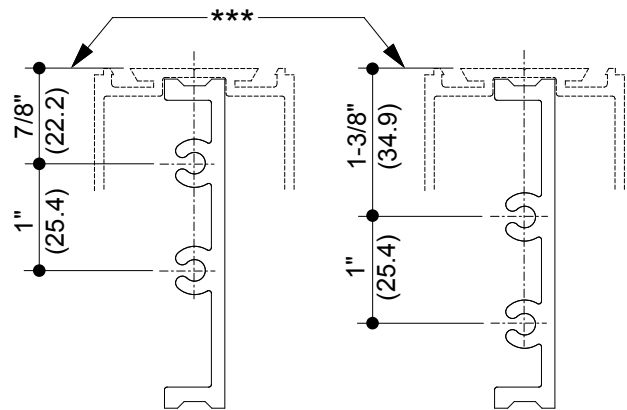

*** Top of Sidelite Base



NOTICE

When using the sidelite base on both sides of the mullion, a clip is required in each pocket of the vertical. One of the clips must be reversed as shown to avoid interference of the screws.

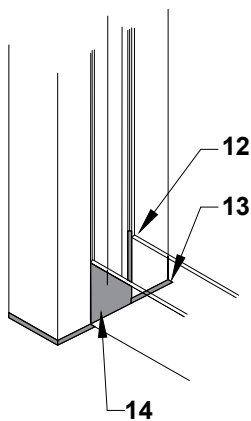

4. Drill through splines of clip with #26 drill into pocket of vertical.
5. Secure clip to vertical with two (2) #10 x 2-5/8" PH screws, 128354.
6. Drill 1/4" weep holes at 1/4 points of channel.
7. Use 129345 screws at setting block points.
8. Set base in bed of sealant.
9. Anchor base to masonry.
10. Seal over heads of perimeter fasteners.
11. Seal interior glass stop continuously across opening and to vertical at ends.
12. Seal channel to mullion.
13. Seal mullion to finished floor.
14. Completely seal bottom of mullion pocket to floor and to channel.

Wide Sidelite Base For Center Glazed Option

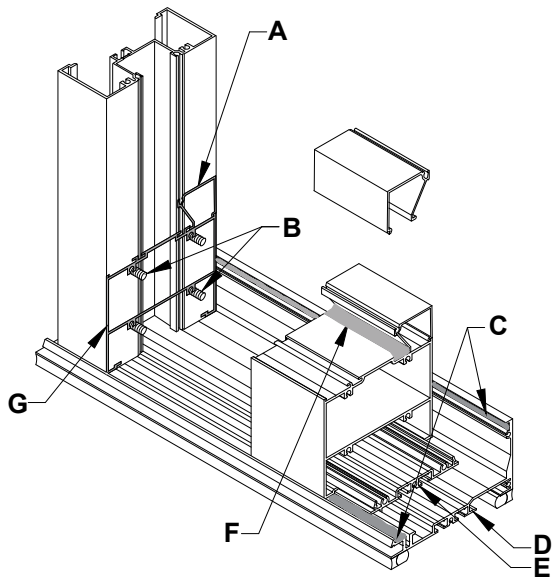

A	Seal end of sidelite base and interior glass stop at verticals.
B	Spline Screws
C	<ol style="list-style-type: none"> 1. Apply sealant to front ledge of flashing. 2. Check for 127043 weathering in top reglet of sill flashing back leg. 3. If weathering was not installed, then fill reglet with sealant. <div style="background-color: #f0f0f0; padding: 10px; margin: 10px 0;"> <p>i NOTICE When each frame is installed there must be good sealant contact between sill and sill flashing.</p> </div> <ol style="list-style-type: none"> a. Apply a continuous bead of sealant to fill reglet. b. Make sealant bead large enough to sit proud of reglet. <ol style="list-style-type: none"> 4. Remove excess sealant from visible surfaces.
D	Sill Flashing
E	<p>Tall Sill Filler Clips 451CG365 located:</p> <ol style="list-style-type: none"> 1. One on each side of vertical mullions with centerline of clips 3" (76.2) from end of sill members 2. Minimum of one sill clip at centerline of DLO with a maximum spacing of 36" (914.4) from adjacent clips 3. Clips must not interfere with anchor fasteners in sill flashing <div style="background-color: #f0f0f0; padding: 10px; margin: 10px 0;"> <p>NOTE Sill clip can be used with all open back sill members.</p> </div>
F	Seal interior glass stop continuous across opening and to verticals at ends.
G	Seal end of sidelite base at verticals.

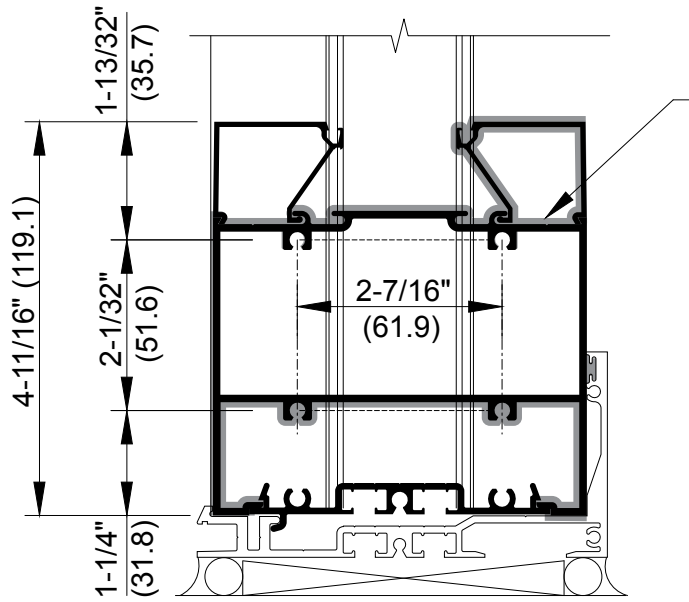

Apply sealant to end of sidelite base and interior glass stop.

451CG001 Sill For Center Glazed Option

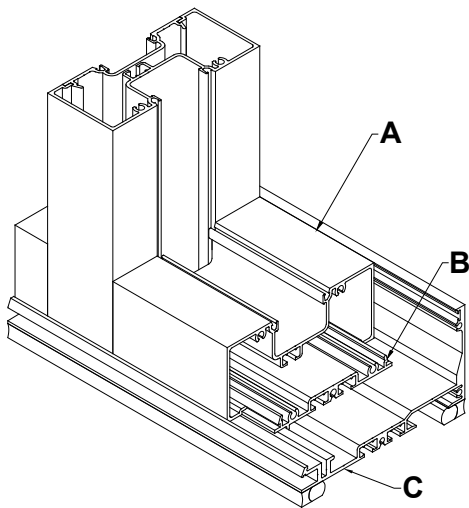

A	451CG001 or 451VG001 Sill
B	451CG365 Tall Sill Filler Clip
C	Sill Flashing

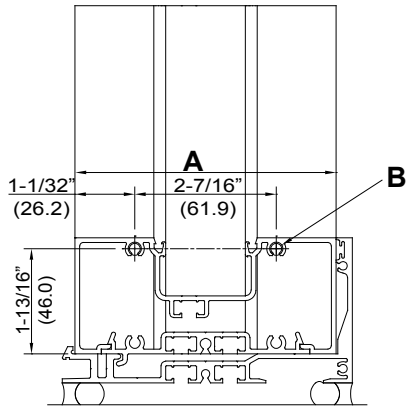

A	4.5 Ref
B	Ø0.228 THRU, TYP 2X

Brake Metal Adapter At Sill For Center Glazed Option

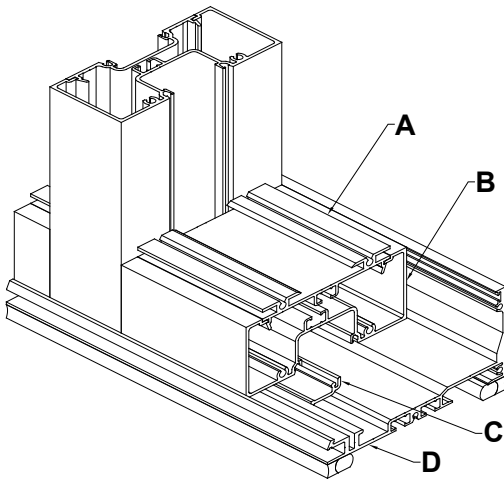

A	451VG150 Brake Metal Adapter
B	451CG001 Sill
C	451CG366 Filler Clip
C	Sill Flashing

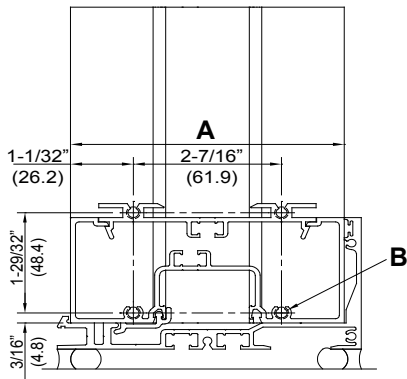

A	4.5 Ref
B	Ø0.228 THRU, TYP 4X

4-1/2" X 4-1/2" Sill For Center Glazed Option

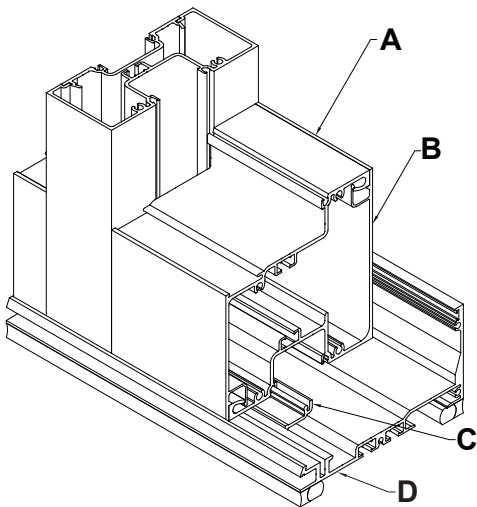

A	451CG115 or 451CG035 Sill
B	451CG035 Sill
C	451CG366 Tall Sill Filler Clip
D	Sill Flashing

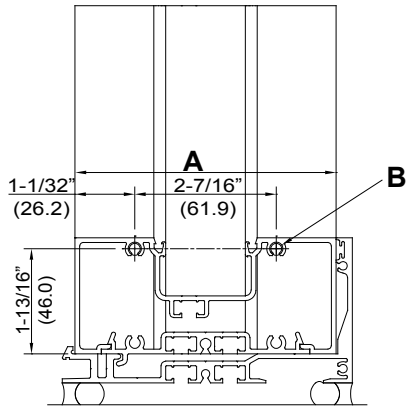

A	4.5 Ref
B	Ø0.228 THRU, TYP 2X

Notes

Notes And Disclaimers

Laws and building and safety codes governing the design and use of Kawneer products, such as glazed entrance, window, and curtain wall products, vary widely. Kawneer does not control the selection of product configurations, operating hardware, or glazing materials, and assumes no responsibility therefor. It is the responsibility of the owner, the specifier, the architect, the general contractor, and the installer and the fabricator/transformer, consistent with their roles, to determine the appropriate materials for a project in strict conformity to all applicable national, regional and local building codes and regulations.

Kawneer reserves the right to change configuration without prior notice when deemed necessary for product improvement.

Information contained herein or related hereto is intended only for evaluation by technically skilled persons, with any use thereof to be at their independent discretion and risk. Such information is believed to be reliable, but Kawneer shall have no responsibility or liability for results obtained or damages resulting from such use.

Kawneer grants no license under, and shall have no responsibility or liability for infringement of, any patent or other proprietary right. Nothing in this document should be construed as a warranty or guarantee by Kawneer, and the only applicable warranties will be those set forth in Kawneer acknowledgment or in any printed warranty documents issued by Kawneer. The foregoing may be waived or modified only in writing by a Kawneer officer.

© 2009, Kawneer Company, Inc.