

YWW 50 TU / YWW 60 TU Window Wall Installation Manual Preglazed SSG

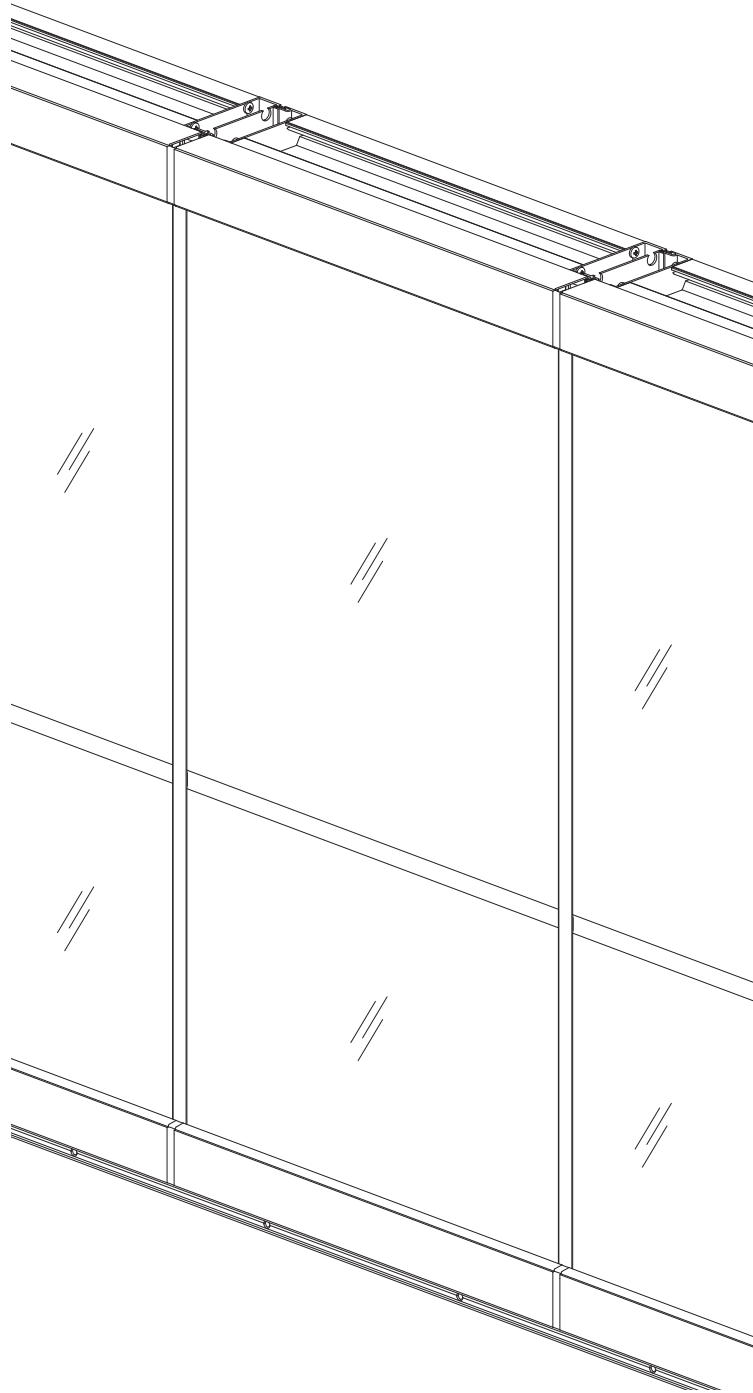

TABLE OF CONTENTS

| | |
|---|----------------|
| Installation Notes..... | Page ii |
| Important Notice | Page iii |
| PARTS DESCRIPTION | |
| Framing Members..... | Pages 1 to 4 |
| Accessories..... | Pages 5 & 6 |
| FRAME FABRICATION | |
| Determine Frame Size..... | Pages 7 & 8 |
| Fabricate Vertical Members..... | Pages 9 & 10 |
| Fabricate Horizontals..... | Pages 11 & 12 |
| Fabricate Fillers & Glass Stops..... | Page 13 |
| Fabricate Sill Flashing..... | Page 14 |
| Fabricate Slab Edge Plate Adaptor..... | Page 15 |
| Fabricate Corner Covers..... | Page 15 |
| Fabricate Head Receptors..... | Page 16 |
| FRAME ASSEMBLY | |
| Assemble Frame..... | Pages 17 to 21 |
| Secure Unit Frame..... | Page 22 |
| Install Steel Reinforcing (Optional)..... | Page 23 |
| Install Perimeter Fillers..... | Page 24 |
| Install Foam Plugs at Head..... | Page 25 |
| Install Weather Seal..... | Page 26 |
| Install Exterior Glazing Gaskets..... | Pages 27 & 28 |
| GLAZING | |
| Install Setting Blocks..... | Page 29 |
| Install Glass..... | Pages 30 & 32 |
| Install Stting Blocks at Head..... | Page 33 |
| Seal Glass to Frame..... | Page 34 |
| Install Glass Stops..... | Pages 35 & 36 |
| Install SSG Rainscreen Gasket..... | Page 37 |
| Install Exterior Wedge Gaskets..... | Pages 38 & 39 |
| Install Joint Plugs..... | Page 40 |
| FRAME INSTALLATION | |
| Install Sill Flashing End Dams..... | Page 41 & 42 |
| Install Sill Flashing..... | Page 43 |
| Install Flashing Splice Sleeve..... | Pages 43 & 44 |
| Install Slab Edge Covers..... | Pages 45 to 52 |
| Install Sill Flashing at Corners..... | Pages 53 & 54 |
| Sill Preparation..... | Pages 55 & 56 |
| Install Frames..... | Pages 57 to 61 |
| Apply Perimeter Sealant..... | Pages 62 to 64 |
| Install Interior Covers..... | Page 65 |

Installation Notes

1. Do not drop, roll or drag boxes of aluminum framing. Move and stack boxes with proper support to prevent distortion. If fork lifts are used, be especially careful about striking the boxes when lifting or moving.
2. Store in a dry, out of the way area. If rain exposure, condensation or any water contact is likely, then all packaging material should be removed. Wet packaging materials will discolor and may stain aluminum finishes and paints.
3. All materials should be checked for quality and quantity upon receipt, YKK AP must be notified immediately of any discrepancies in shipment. Check to make sure that you have the required shims, sealants, supplies and tools necessary for the installation.
4. Carefully check the openings and surrounding conditions that will receive your material. Remember, if the construction is not per the construction documents, it is your responsibility to notify the general contractor in writing. Any discrepancies must be brought to the general contractor's attention before you proceed with the installation.
5. Gather your shop drawings, materials, packing list, and this installation manual. Carefully review parts location, the sequence it goes therein, when you glaze it and how you seal it. Installation instructions are of a general nature and may not cover every condition you will encounter. The shop drawings and/or installation manuals were prepared specifically for the product.
6. Any material substitutions must be of equal or greater quality.
7. Make certain that material samples have been sent for compatibility testing for all manufacturer's sealants involved. Make certain sealants have been installed in strict accordance with the manufacturer's recommendations and specifications.
8. Remember to isolate, in an approved manner, all aluminum from uncured masonry or other incompatible materials.
9. System-to-structure fasteners are not supplied by YKK AP. Fasteners called out on shop drawings are to indicate minimum sizes for design loading.
10. If any questions arise concerning YKK AP products or their installation, contact YKK AP for clarification before proceeding.
11. YKK AP storefront and/or curtain wall framing is typically completed before drywall, flooring and other products which may still be in process. Take the extra time to wrap and protect the work produced.
12. Cutting tolerances are plus zero, minus one thirty second unless otherwise noted.
13. Check our website, www.ykkap.com, for the latest installation manual update prior to commencing work.

Important Notice for SSG Window Wall Systems:

In order to properly perform and to maintain structural integrity, in addition to all other installation requirements, structurally glazed window wall systems rely specifically upon effective and appropriate structural sealant selection and installation.

It is the responsibility of the glazing contractor to take all steps to ensure the installed structural sealant is capable of meeting all applicable project requirements in accordance with industry standards. Such steps on each project may include, but are not limited to, design reviews, formal adhesion testing, project specification compliance, validating applications, field testing, auditing, sealant design strength analysis, and the quality control review of the installation and surrounding conditions.

Subject to project specific design pressures, requirements, and/or specifications, the structural sealant that is used between the glass and framing system must be capable of withstanding tensile and shear stresses imposed by the window wall without failing adhesively or cohesively.

The structural sealant's capability to withstand these stresses are dependent on several factors including, but not limited to, type of structural sealant, method of application (i.e. cleaning, primer), construction of glazing material (i.e. insulating glass unit (IGU), other infill, and finish of framing (i.e. anodizing, paint).











- Adhesive failure occurs when sealant pulls away from substrate cleanly, leaving no sealant material behind.
- Cohesive failure occurs when sealant breaks or tears within itself but does not separate from each substrate because sealant-to-substrate bond strength exceeds sealant's internal strength.

The IGU and/or other infill must be constructed for installation into structurally sealant glazed window walls. Notify the manufacturer or fabricator of the IGU and/or infill and advise of the product's application into 2 or 4-sided structurally sealant glazed window walls along with the project's design requirements so that appropriate fabrication steps are taken.

YWW 50TU FRAMING MEMBERS

| | | | | | |
|--|---|-----------------|--|--|-----------------|
| | Male Mullion | BE9-2764 | | Head Receptor | BE9-7635 |
| | Female Mullion | BE9-2765 | | Optional Head Receptor | BY7-8426 |
| | Female SSG Mullion | E9-2768 | | Head Receptor w/ Plate Adaptor | BE9-2819 |
| | Male SSG Mullion | E9-2769 | | Receptor Snap Cover Used with BE9-7635 | E9-8720 |
| | Jamb 2-1/4" x 5" | BE9-2766 | | Receptor Snap Cover Used with BE9-2819 | E9-8715 |
| | Corner Mullion Half 2-1/4" x 5" | BE9-2779 | | 90° Corner Cover (Large) | E9-2783 |
| | Head (OG) 2-1/2" x 6" | BE9-2771 | | 90° Corner Cover (Small) | E9-2741 |
| | Horizontal (OG) | BE9-2772 | | 135° Corner Cover (Large) | E9-2784 |
| | SSG Horizontal | E9-2770 | | 135° Corner Cover (Small) | E9-2743 |
| | Sill (OG) | BE9-2773 | | Flush Filler | E9-2780 |
| | Sill Flashing | BE9-2774 | | Exterior Glass Stop | E9-1715 |
| | Sill Flashing for Slab Edge | BE9-2775 | | Aluminum Plate Adaptor For BE9-2735 | E9-8222 |









YWW 50 TU FRAMING MEMBERS

| | | | | |
|---|---|-----------------------|---|---|
|  | <p>6-1/8" Slab Edge Cover For Use with 5-1/8" Slab</p> | <p>E9-8059</p> |  | <p>9" Slab Edge Cover For Use with 8" Slab</p> <p>E9-8428</p> |
|  | <p>6-5/8" Slab Edge Cover For Use with 5-5/8" Slab</p> | <p>E9-7723</p> |  | <p>Anchor</p> <p>E9-2732</p> |
|  | <p>7-3/8" Slab Edge Cover For Use with 6-3/8" Slab</p> | <p>E9-8223</p> |  | <p>Door Jamb Adaptor Subframe</p> <p>E9-2344</p> |
|  | <p>7-7/8" Slab Edge Cover For Use with 7-7/8" Slab</p> | <p>E9-8231</p> |  | <p>4-1/2" x 1-3/4" Door Head</p> <p>AS-0402</p> |
|  | <p>8" Slab Edge Cover For Use with 7" Slab</p> | <p>E9-8589</p> |  | <p>Flat Filler Use with BE9-2765</p> <p>BY7-9241</p> |



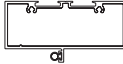



YWW 60 TU FRAMING MEMBERS

| | | | | | |
|--|---|----------|--|--|----------|
| | Female Mullion | BE9-2746 | | Head Receptor | BE9-7736 |
| | Male Mullion | BE9-2747 | | Head Receptor w/ Plate Adaptor | BE9-7299 |
| | Female SSG Mullion | E9-2750 | | HD Receptor Snap Cover Used with BE9-7736 & BE9-7299 | E9-8157 |
| | Male SSG Mullion | E9-2751 | | 90° Corner Cover (Large) | E9-2783 |
| | Jamb 2-1/4" x 5" | BE9-2748 | | 90° Corner Cover (Small) | E9-2741 |
| | Corner Mullion Half 2-1/4" x 5" | BE9-2761 | | 135° Corner Cover (Large) | E9-2784 |
| | Head (OG) 2-1/2" x 6" | BE9-2753 | | 135° Corner Cover (Small) | E9-2743 |
| | Horizontal (OG) | BE9-2754 | | Flush Filler | E9-2762 |
| | SSG Horizontal Mullion | E9-2752 | | Exterior Glass Stop | E9-1715 |
| | Sill (OG) | BE9-2755 | | Aluminum Plate Adaptor For BE9-2735 | E9-8222 |
| | Sill Flashing | BE9-2756 | | 6-1/8" Slab Edge Cover For Use with 5-1/8" Slab | E9-8059 |
| | Sill Flashing for Slab Edge | BE9-2757 | | 6-5/8" Slab Edge Cover For Use with 5-5/8" Slab | E9-7723 |



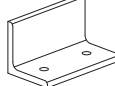
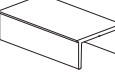

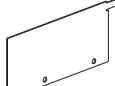







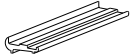

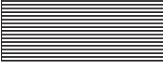

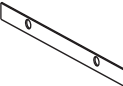

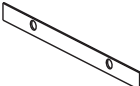

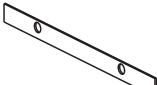

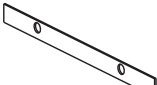

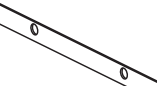
YWW 60 TU FRAMING MEMBERS

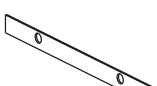
| | | | | | |
|---|---|----------------|---|--------------------------------------|-----------------|
|  | 7-3/8" Slab Edge Cover For Use with 6-3/8" Slab | E9-8223 |  | Strap Anchor For YWW 60 TU | E9-2733 |
|  | 7-7/8" Slab Edge Cover For Use with 7-7/8" Slab | E9-8231 |  | Door Jamb Adaptor Subframe | E9-2344 |
|  | 8" Slab Edge Cover For Use with 7" Slab | E9-8589 |  | 4-1/2" x 1-3/4" Door Head | AS-0402 |
|  | 9" Slab Edge Cover For Use with 8" Slab | E9-8428 |  | Flat Filler | BY7-9241 |
|  | Head Anchor | E9-2732 | | | |

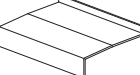
ACCESSORIES

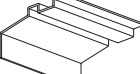
| | | | | | |
|---|--|----------------|---|---|----------------|
|  | Head Anchor 10" Cut Length, for Non-Impact Glazing | E1-1190 |  | Door Jamb Mullion Anchor (1-7/8") | E1-1195 |
|  | Strap Anchor 10" Cut Length For YWW 60 TU | E1-1191 |  | Door Jamb Anchor (3-5/8") | E1-1199 |
|  | Anchor Filler 4" Cut Length For YWW 60 TU | E1-1194 |  | End Dam For YWW 50 TU Sill Flashing | E1-1141 |
|  | Jamb Strap Anchor 4" Cut Length For YWW 50 TU | E1-1143 |  | End Dam For YWW 60 TU Sill Flashing | E1-1142 |
|  | Jamb Strap Anchor 4" Cut Length For YWW 60 TU | E1-1149 |  | End Cap (YWW 50 TU) For BE9-7635 & BE9-8426 Head Receptor | E1-9841 |

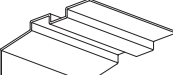
ACCESSORIES

| | | | | | |
|---|--|----------------|--|---|----------------|
|  | End Cap (YWW 50 TU) For BE9-2819 Slab Edge Head Receptor | E1-9952 |  | Head Receptor Splice Sleeve For Slab Edge | E1-9961 |
|  | End Cap (YWW 60 TU) For BE9-7736 Head Receptor | E1-9855 |  | Setting Block Chair | E1-3545 |
|  | End Cap (YWW 60 TU) For BE9-7299 Slab Edge Head Receptor | E1-9822 |  | Silicone Splice Sleeve | E2-0070 |
|  | End Cap For Slab Edge Sill Flashing Adaptor | E1-1196 |  | Flat Filler PVC For YWW 50 TU | E3-0032 |
|  | End Cap For E9-8059 Slab Edge Cover Plate | E1-9984 |  | Flat Filler PVC For YWW 60 TU | E3-0023 |
|  | End Cap For E9-7723 Slab Edge Cover Plate | E1-9985 |  | PVC Perimeter/Pocket Filler | E3-3664 |
|  | End Cap For E9-8223 Slab Edge Cover Plate | E1-9953 |  | Airtight Gasket | E2-0051 |
|  | End Cap For E9-8231 Slab Edge Cover Plate | E1-9954 |  | Weather Seal Gasket For Mullion Halves | E2-7010 |
|  | End Cap For E9-8589 Slab Edge Cover Plate | E1-9955 |  | Weathering Gasket For Slab Edge Cover | E2-0065 |
|  | End Cap For E9-8428 Slab Edge Cover Plate | E1-9956 |  | Anti-Walk Block For Female Mullion | E2-0546 |
|  | Splice Sleeve For Sill Flashing at Slab Edge | E1-9959 |  | Side Block For Male Mullion | E2-0133 |
|  | Head Receptor Splice Sleeve For YWW 50 T | E1-2813 |  | Setting Block | E2-0150 |
|  | Head Receptor Splice Sleeve For YWW 60 T | E1-9824 |  | SSG Setting Block | E2-0224 |

ACCESSORIES

| | | | | | |
|---|---|----------------|---|--|------------------------------|
|  | Setting Block For Top of Glass | E2-0068 |  | SSG Spacer for Horizontal | E2-7007 |
|  | Setting Block For Jamb | E2-0628 |  | SSG Rainscreen Gas- ket | E2-0540 |
|  | Setting Block for Intermediate Horizontals | E2-0178 |  | Weep Baffle | E2-0099 |
|  | Setting Block For Slab Edge Cover | E2-0054 |  | Drill Fixture | H-7264 |
|  | Water Deflector | E2-0047 |  | #10" x 3/8" PHMS Stainless Steel, For Corner Cover Attachment | PM-1006 -SS |
|  | SSG Joint Plug | E2-9802 |  | #12 x 3/4" UFHSMS Type A , Zinc Plated Steel, For End Dam Attachment | UA-1212 |
|  | Foam Backer Tape 1" x 1-1/4" (Roll) | E2-0259 |  | #12 x 1" FHSMS Type AB , Used with E1-1192 Strap Anchor | FC-1216 |
|  | 1/4" x 1/4" Spacer Tape | E2-0110 |  | #12 x 5/8" PHSMS Type AB , Zinc Plated Steel | PC-1210 |
|  | Dart Gasket (Silicone) 1/4" F.C. | E2-0541 |  | #12 x 1-1/4" PHSMS Type AB , Zinc Plated Steel | PC-1220 |
|  | Wedge Gasket (Silicone) 1/4" F.C. | E2-0542 |  | #25 x 1" PHMS , Stainless Steel | PM-2508- SS |
|  | SSG Spacer For Verticals | E2-0544 | | | |

FRAME FABRICATION

STEP 1 DETERMINE FRAME SIZE

Determine Frame Width:

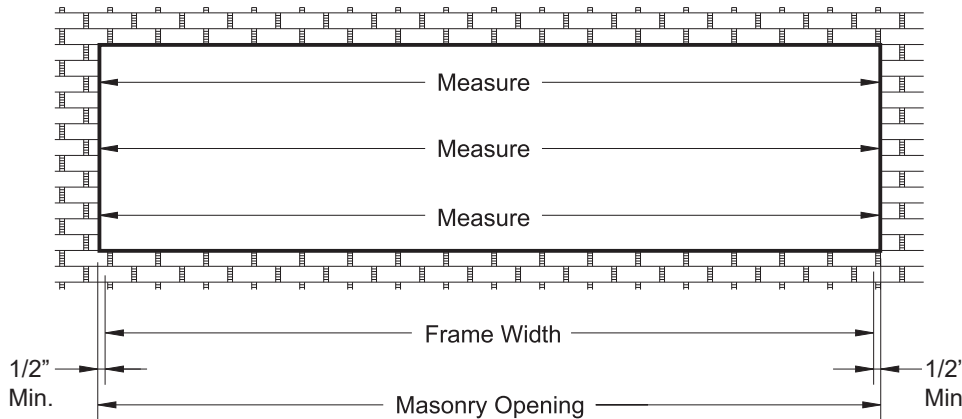

Note: Check opening for squareness of plumb at both ends, units must be installed in a true rectangle.

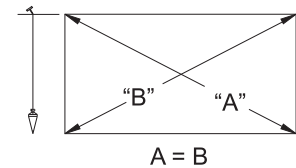

DETAIL 1

- Measure the width of the masonry opening at the top, middle, and bottom.
 - Select the smallest dimension measured and subtract 1" to determine the frame width.
- See **Detail 1**.

Note: For additional possibilities such as slab edge cover application, it is recommended to increase the caulk joint at the jambs to facilitate installation of the last framed unit. (Unit width will proportionally affect caulk joint width.)

Determine Frame Height:

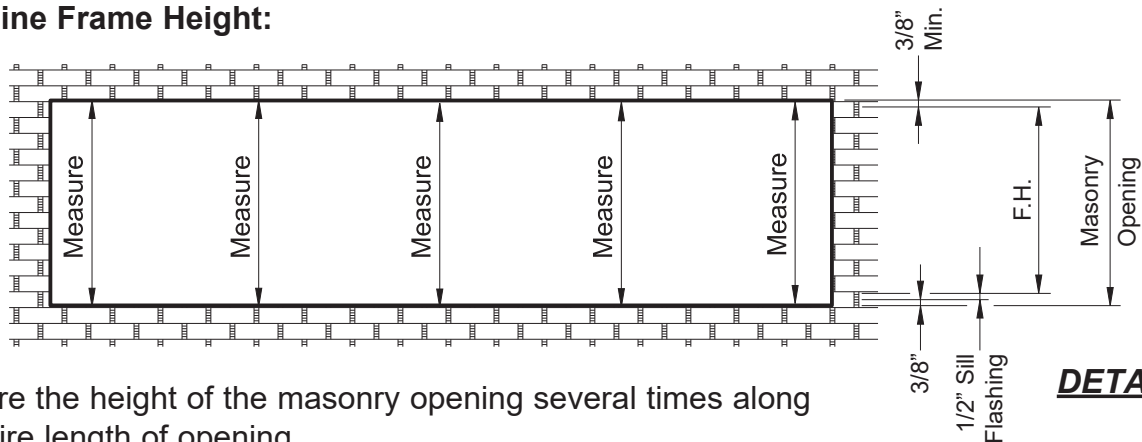

DETAIL 2

- Measure the height of the masonry opening several times along the entire length of opening.
- Select the smallest dimension measured and subtract *1-1/4" to determine the frame height to be used.

Minimum of 3/8" shim/caulk joint at the head.

1/2" for the sill flashing.

Minimum 3/8" shim/caulk joint below the sill flashing.

See **Detail 2**.

* **Note:** 1-1/4" is based on 3/8" perimeter caulk joint, which can vary per project.

FRAME FABRICATION

**STEP 1 (Continued)
DETERMINE FRAME SIZE**

Determine Frame Height for Slab Edge Conditions:

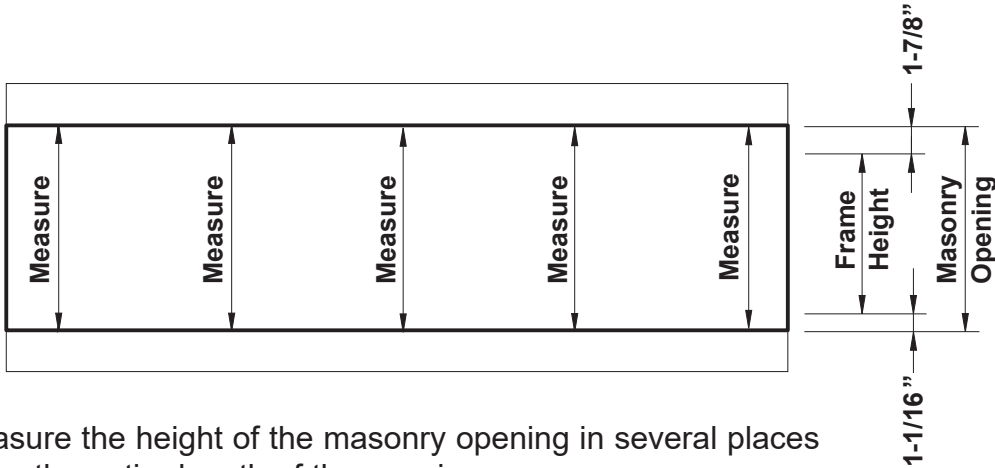

- Measure the height of the masonry opening in several places along the entire length of the opening.
- Select the smallest dimension measured and subtract *2-15/16" to determine the frame height to be used:
 - 5/8" for the shim/caulk joint at the head.
 - 1-1/4" for the head receptor.
 - 7/16" for the sill flashing.
 - 5/8" for the shim/caulk joint below the sill flashing.

Detail 3

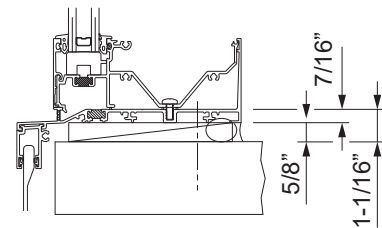
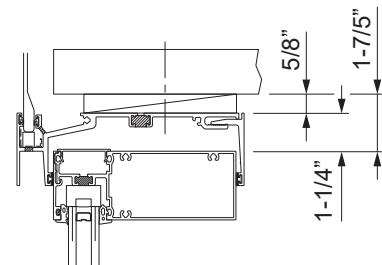

See **Detail 3**.

* **Note:** 2-15/16" is based on 5/8" perimeter caulk joint, which can vary per project.

FRAME FABRICATION

STEP 2
FABRICATE VERTICAL MEMBERS

- Cut all jamb and two piece vertical members to the frame height determined in **Step 1**.
- Fabricate holes in the vertical members for screw spline attachment using one of the methods below:
 - Using the H-7264 drill fixture as a template, line up the glazing pockets and mark hole locations through the screw splines of the templates.
 - OR**
 - Layout hole locations on vertical members as shown in **Detail 4**.
- Drill 0.236" diameter (#B drill bit) holes at each location marked.

Note: Additional fabrication will be required for the inclusion of steel reinforcing. Drill fixture plate can be used.

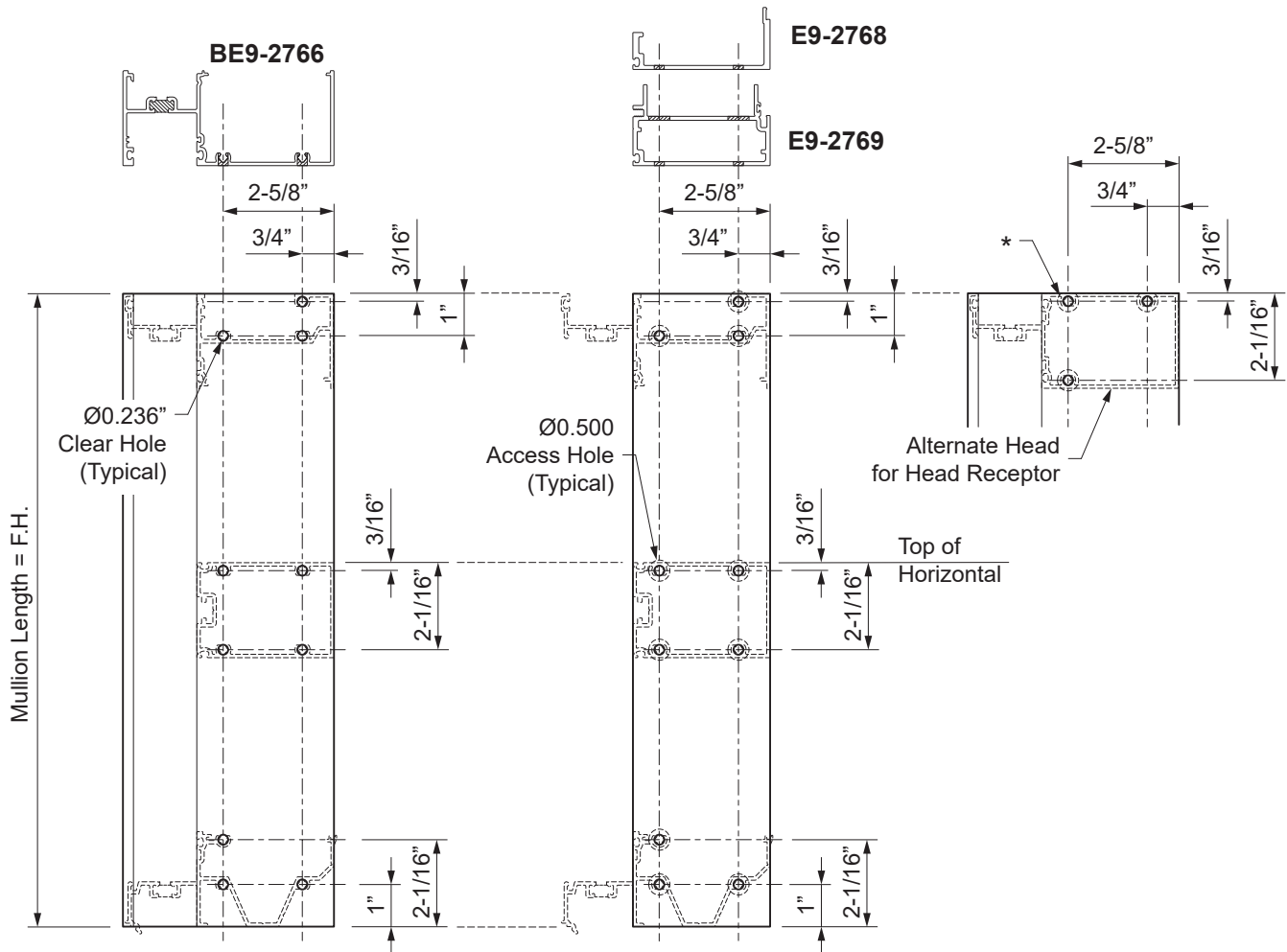

Detail 4

FRAME FABRICATION

**STEP 2 (Continued)
FABRICATE VERTICAL MEMBERS**

-For hollow vertical members, fabricate access holes in addition to the clear holes according to the methods previously shown and in **Detail 5**.

Note: Additional fabrication will be required for the inclusion of steel reinforcing.

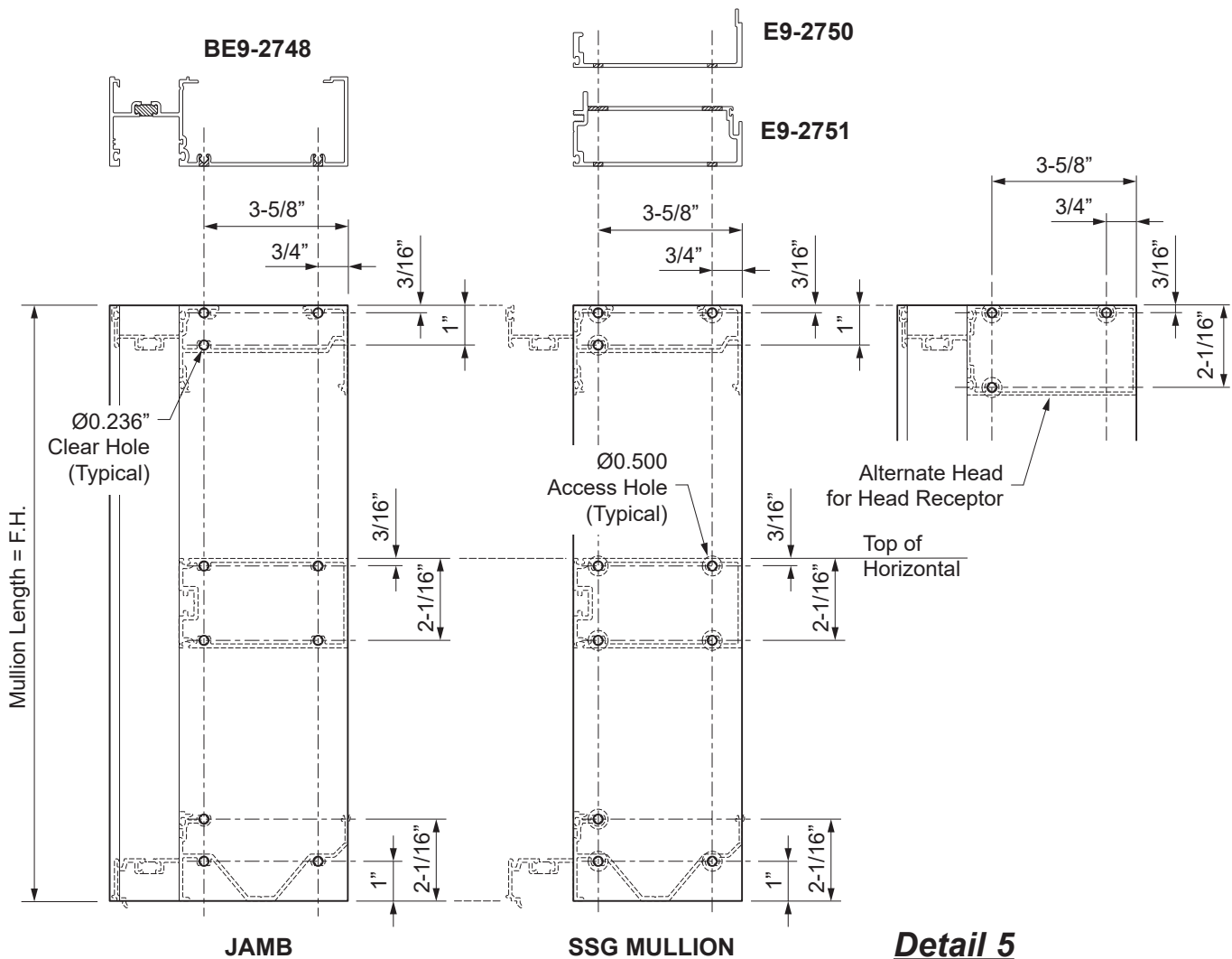

Detail 5

FRAME FABRICATION

STEP 3
FABRICATE HORIZONTALS

- Cut all SSG horizontals to the horizontal daylight opening.
- Cut all head and sill members to the horizontal daylight opening plus(+) the numbers as shown in **Details 6 & 7**.

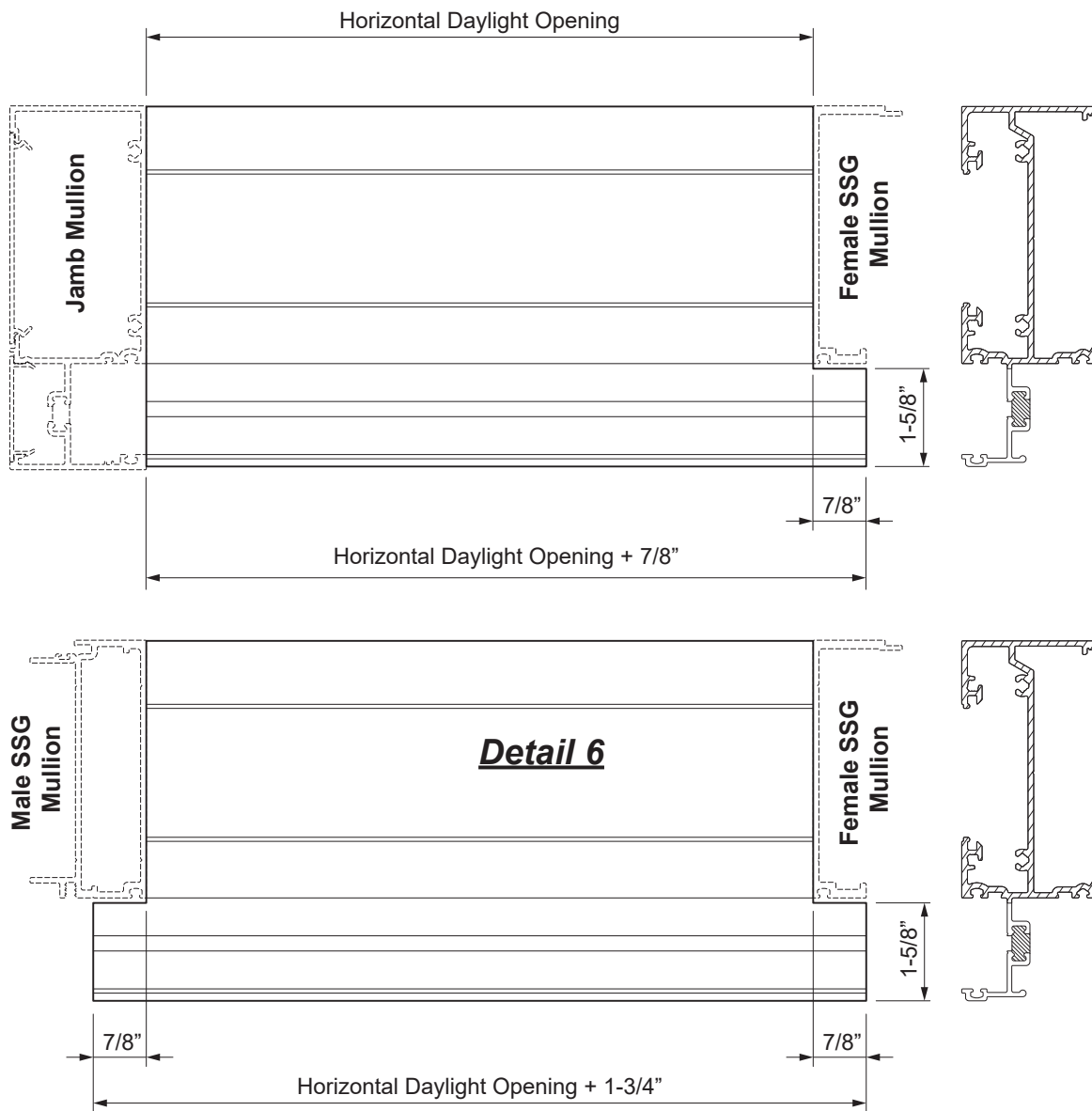

FRAME FABRICATION

**STEP 3 (Continued)
FABRICATE HORIZONTALS**

-Sill members will require additional 0.281" diameter clear holes at 1-1/2" and 3" from the ends, centered along the v-groove as shown in **Detail 7**.

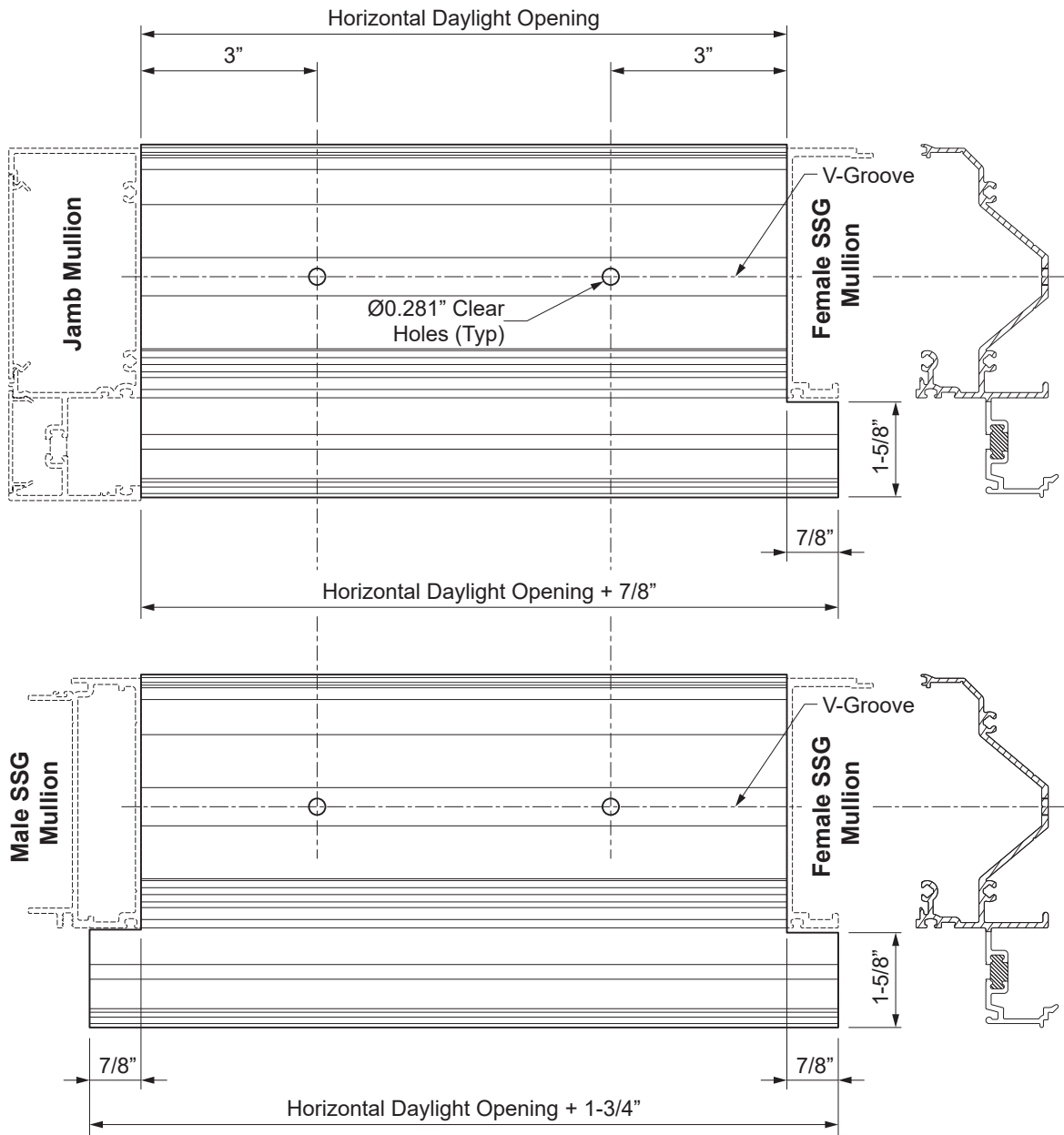

Detail 7

FRAME FABRICATION

STEP 3 (Continued)
FABRICATE HORIZONTALS

When the head is anchored to the substrate with the E1-1190 anchor, access holes will need to be drilled into the head member.

- Temporarily clamp the E1-1190 anchor onto the head where it will be in relation to the head member once anchored to the substrate.
- Drill 5/16" diameter holes into the head in line with the holes in the anchor. Unclamp the anchor. Then drill the access holes out to 3/4" diameter.

Notes: This is in addition to the 0.189" diameter tap holes for the glass stop. Refer to FPA drawings or shop drawings for appropriate fastener and hole locations as determined by a qualified engineer.

See **Detail 8**.

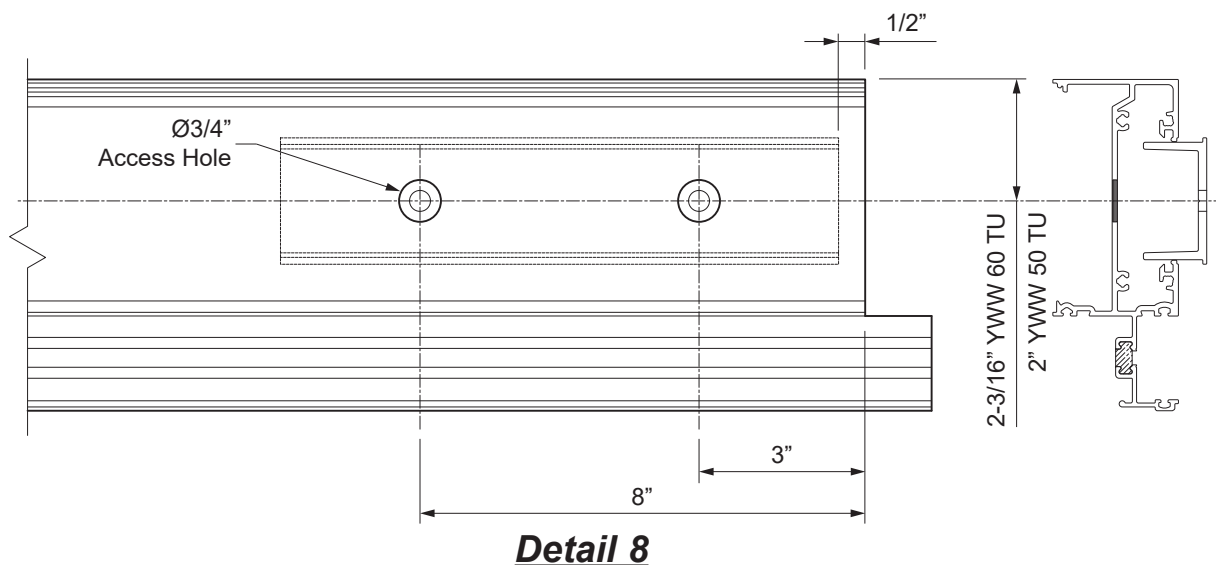

FRAME FABRICATION

**STEP 4
FABRICATE FILLERS & GLASS STOPS**

- Cut all vertical perimeter PVC flat fillers to the length of the jambs, except where strap anchors would interfere with the jamb filler.
- Cut all horizontal flush fillers and flat fillers to horizontal daylight opening minus(-) 1/32".

See **Detail 9**.

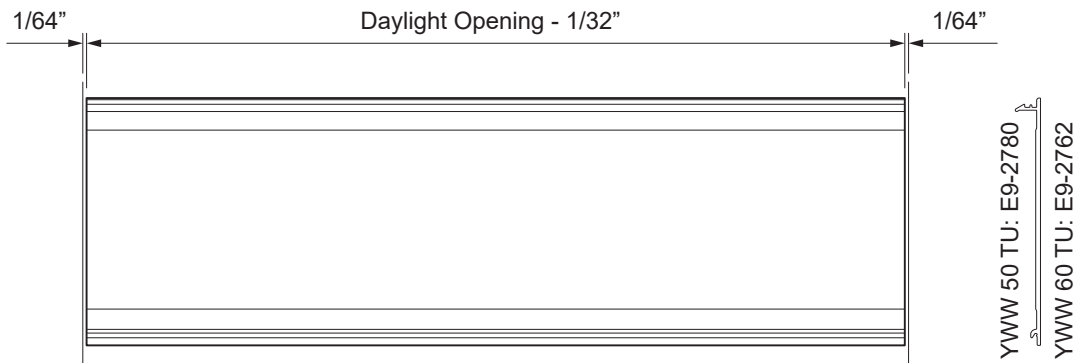

Detail 9

- Cut E9-1715 exterior glass stops to the dimensions shown below in **Detail 10**.

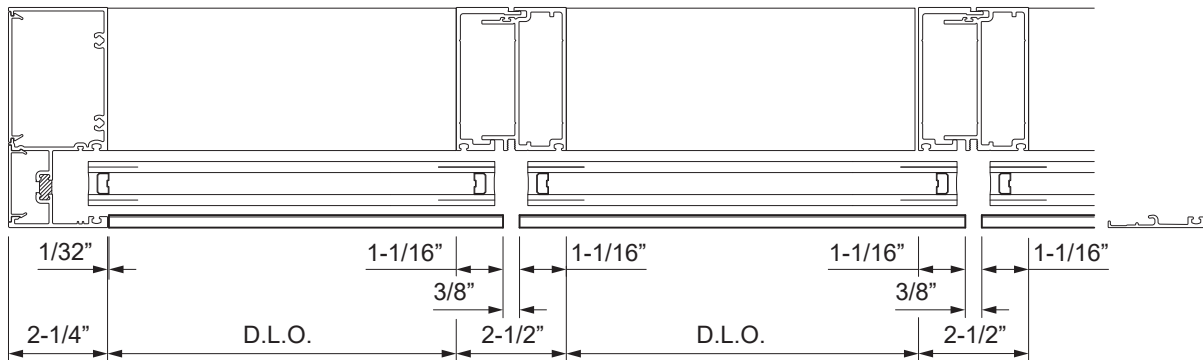

Detail 10

FRAME FABRICATION

STEP 5
FABRICATE SILL FLASHING

-Cut the sill flashing to the frame width plus(+) 5/16" at each jamb.

Note: For additional possibilities such as slab edge cover application, it is recommended to provide additional space between the edge of the sill flashing and the jamb substrate.

-For frame openings longer than 24'-0", allow for a 3/8" splice joint between sill flashing members every twelve to fifteen feet at the center of a daylight opening (best location next to the door jamb.)

-Mark the front face of the sill flashing at the center of each vertical location and the midpoint of the daylight opening between the verticals.

-Drill a 5/16" diameter weep hole in the face of the sill flashing at each location marked.

See **Detail 11**.

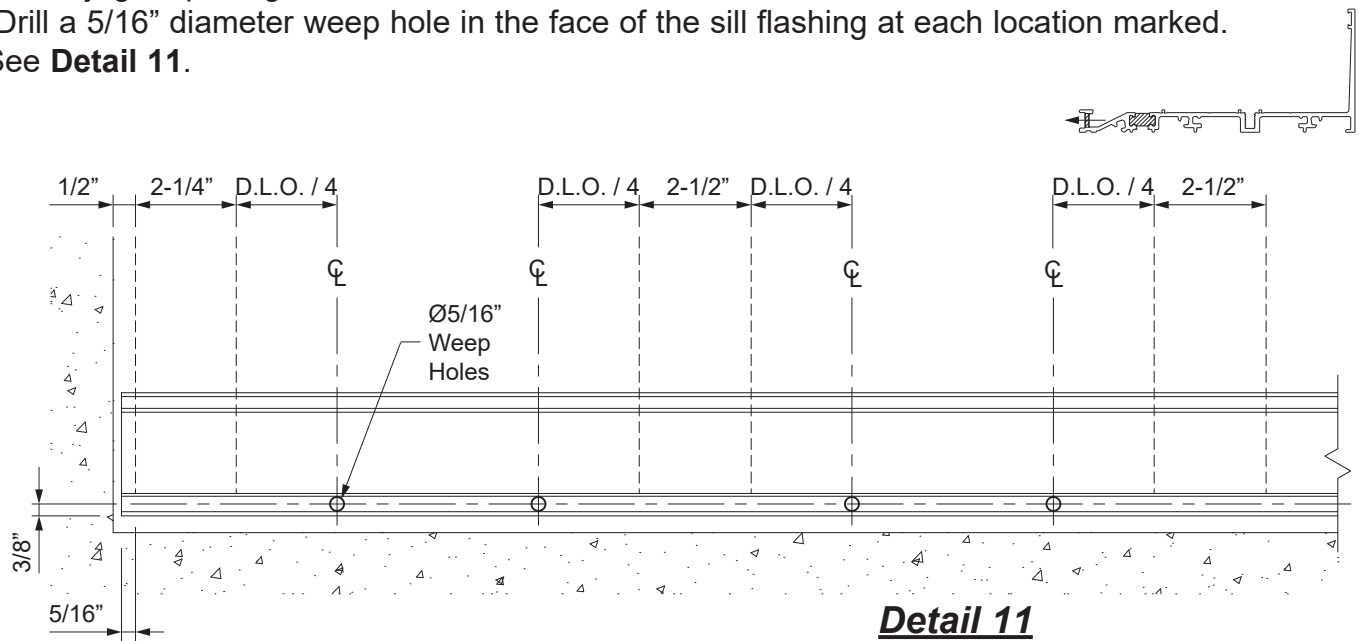

Additional fabrication will be required for BE9-2775 and BE9-2757 sill flashings used at slab edge covers if splices are needed.

-Notch the sill flashing as shown in **Detail 12**.

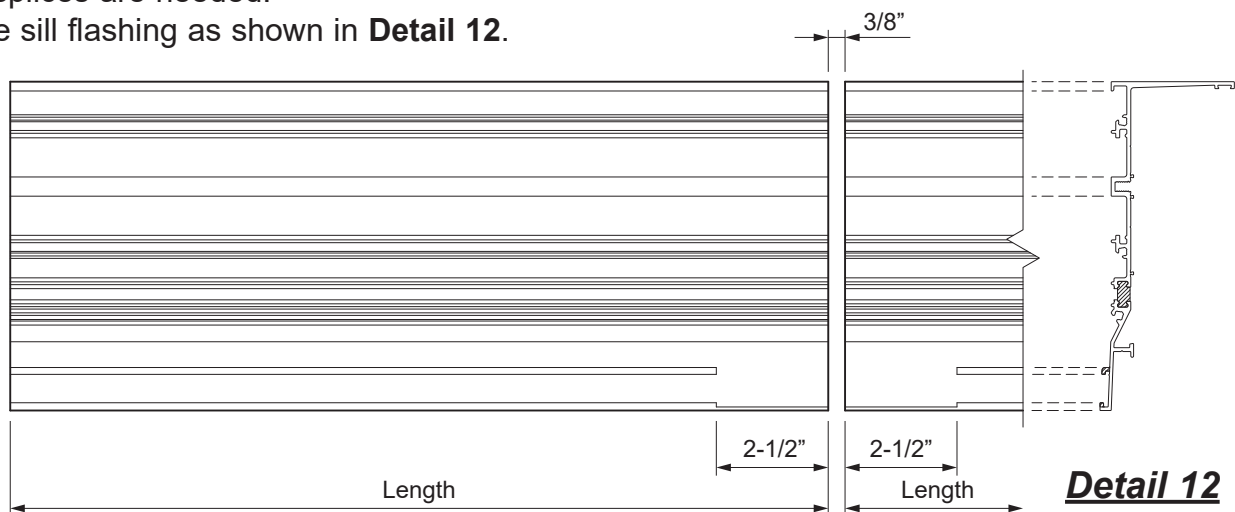

FRAME FABRICATION

**STEP 5A
FABRICATE SLAB EDGE PLATE ADAPTOR**

- Cut the aluminum plate adaptor E9-8222 to the same length as the sill flashing.
- Notch the aluminum plate adaptor 2-1/2" from each end at each splice joint location as shown in **Detail 13**.
- Cut slab edge cover plates to length as indicated on the approved shop drawings

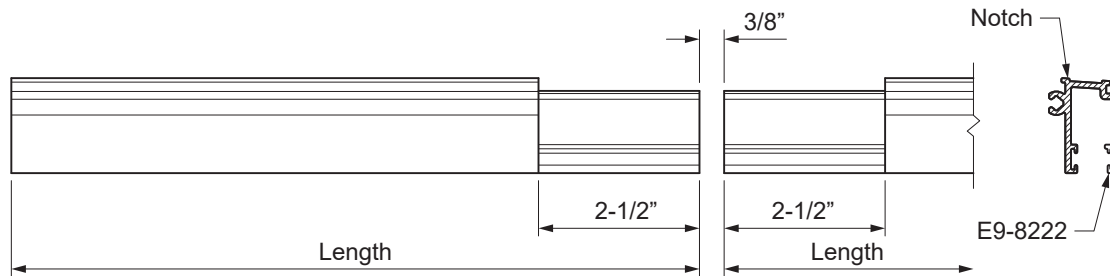

Detail 13

**STEP 6
FABRICATE CORNER COVERS**

- Cut the corner cover components to the mullion length. Drill 0.213" diameter holes into the cover at the v-groove where the cover will be fastened to the mullion at 3" from each end and at 24" maximum on center.

See **Detail 14**.

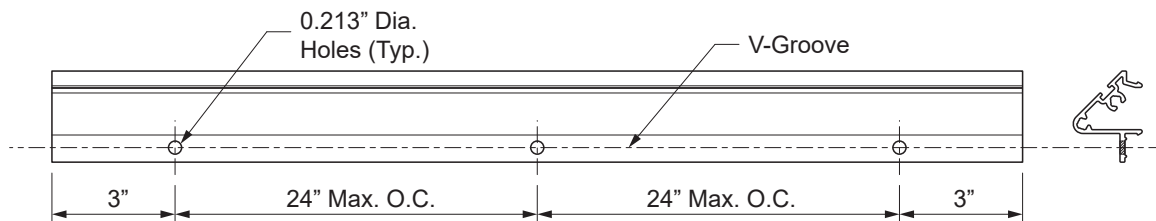

Detail 14
E9-2741 Shown,
Others Similar

FRAME FABRICATION

**STEP 7
FABRICATE HEAD RECEPTOR**

-Cut the head receptor to the frame width plus(+) 5/16” at each jamb.

Note: For additional possibilities such as slab edge cover application, it is recommended to provide additional space between the edge of the head receptor and the jamb substrate.

- For frame openings longer than 24’-0”, allow for a 3/8” splice joint between sill flashing members every twelve to fifteen feet at the center of a D.L.O.
- Mark the front face of the head receptor at the center of each vertical location and the midpoint of the daylight opening between the verticals.
- Drill a 1/4” diameter weep holes in the head receptor at each location marked.
- Drill clear holes for anchor fasteners into the head receptor as indicated on the approved shop drawings and or P.E. calculations.

See **Detail 15**.

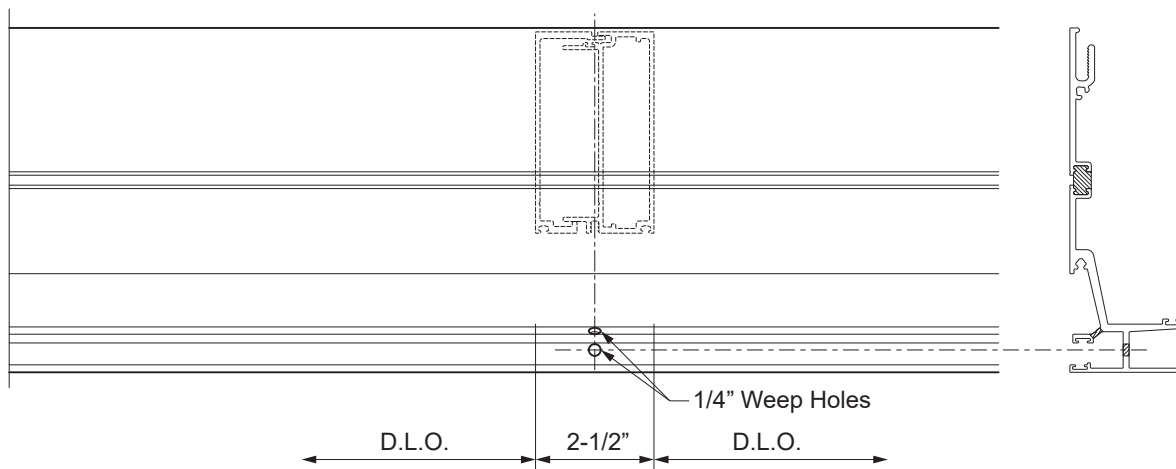

Detail 15
 Note: Anchor Hole
 Locations Shown
 for Reference Only

FRAME ASSEMBLY

**STEP 8
ASSEMBLE FRAME**

Note: It is recommended to lay out the unit pieces face down on a table or saw horses during assembly, fully supporting the mullions. If using saw horses, a brace tying the two together will be required.

-If strap anchors are used at the head, insert them into the head member prior to assembly (2 per Daylight Opening, unless otherwise noted).

-Apply sealant to the end of the horizontal members to be attached to the first mullion or jamb, at the shaded areas of the head and intermediate horizontals and the entire end of the sill.

See **Detail 16**.

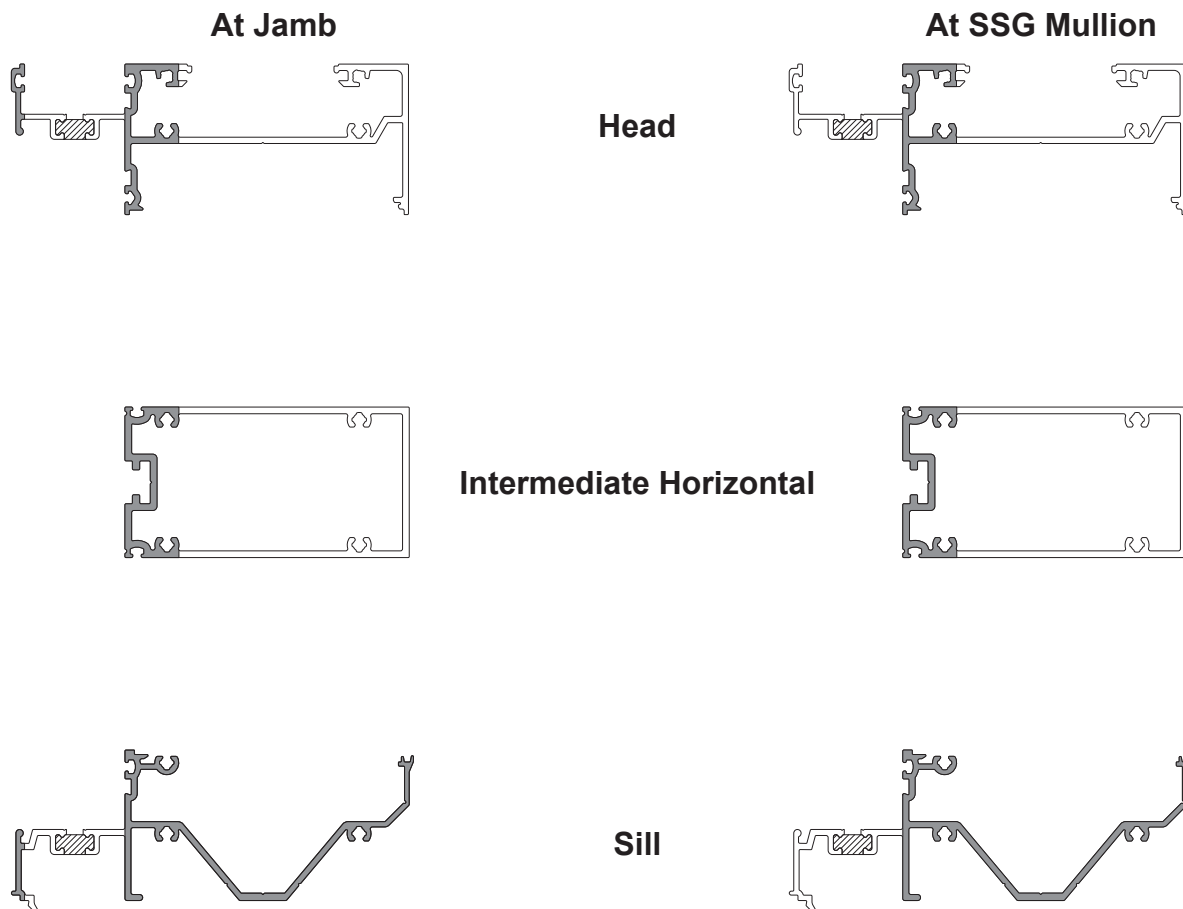

Detail 16

FRAME ASSEMBLY

STEP 8 (Continued)
ASSEMBLE FRAME

-Attach the horizontal members to the first mullion or jamb using PC-1220 screws, ensuring the bottom and back of the sill aligns with the bottom and back of the mullion as shown in **Detail 17A**.

See **Detail 17**.

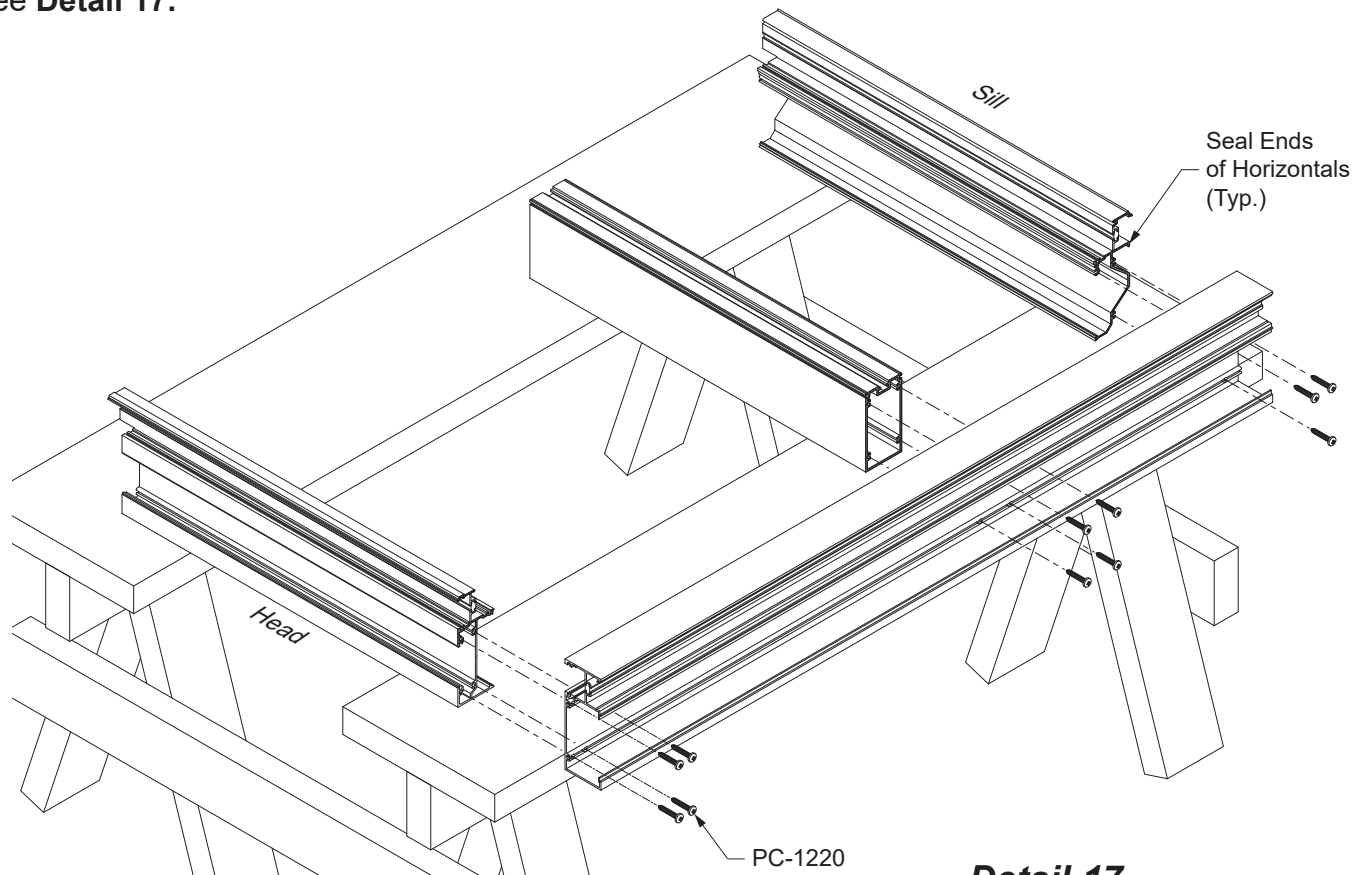

Detail 17
Jamb Mullion shown,
Female Mullion Similar

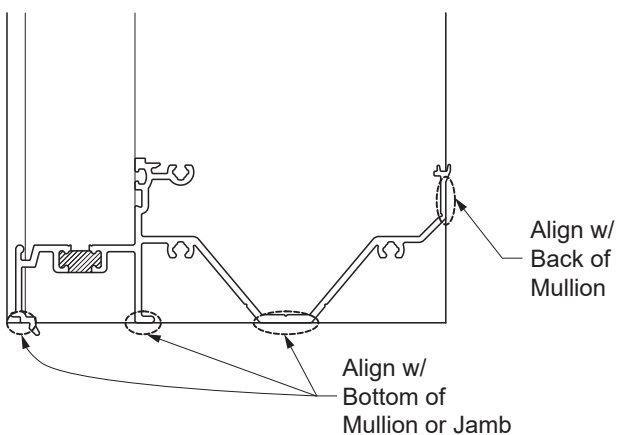

Detail 17A

FRAME ASSEMBLY**STEP 8 (Continued)
ASSEMBLE FRAME**

- Apply sealant to the end of the head, horizontals, and sill that is to be attached to the second mullion or jamb as previously shown in **Detail 17**, also ensuring proper alignment at the bottom of the mullion.
- Attach the horizontal members to the mullion using PC-1220 screws. See **Detail 18**.

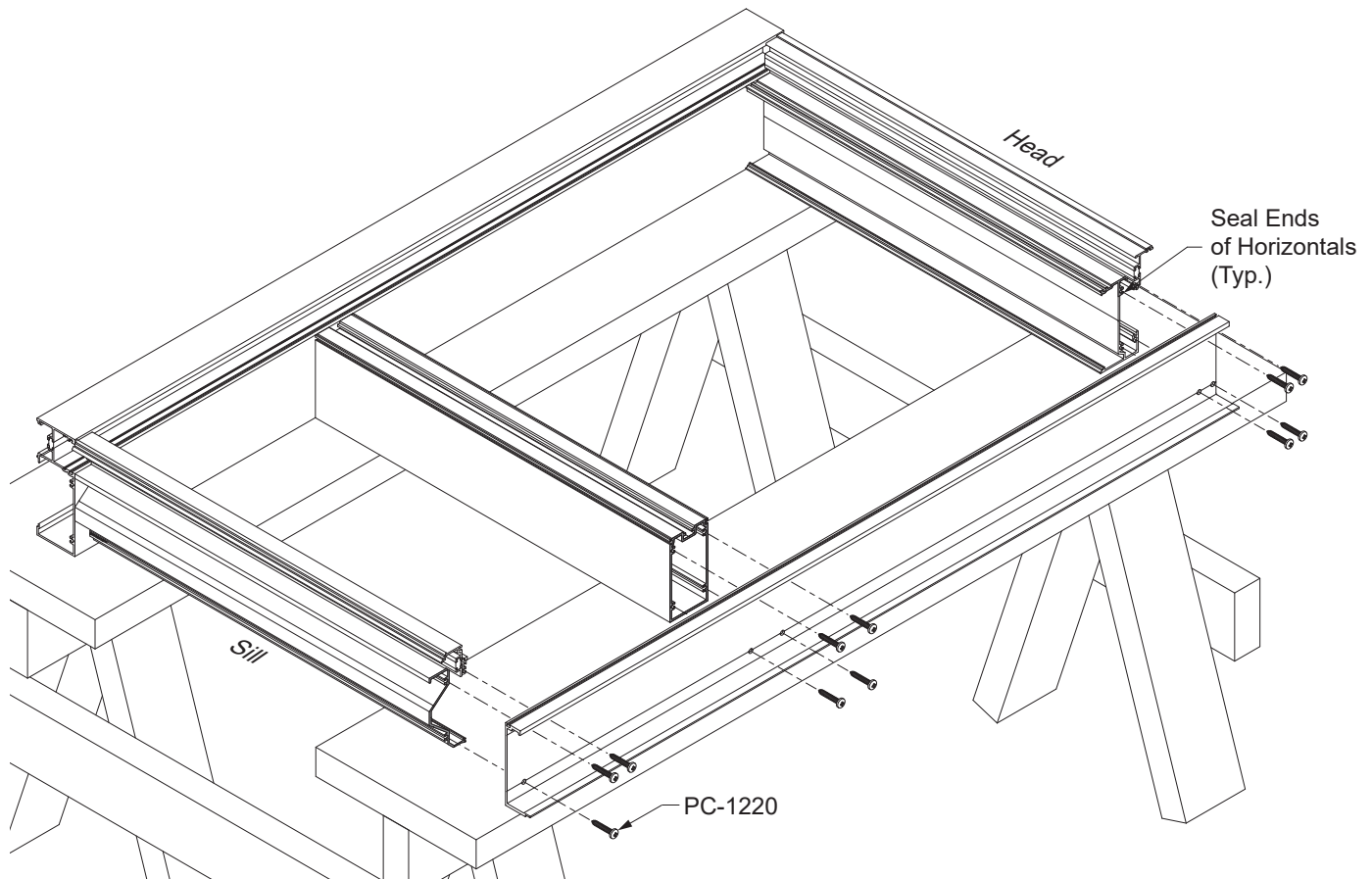
**Detail 18**

FRAME ASSEMBLY

STEP 8 (Continued)
ASSEMBLE FRAME -- CORNER MULLION

- Apply sealant to the interior snap interface of the interior corner cover, 6" up from the bottom of the mullion. Snap the cover pieces onto the corner mullion half. Fasten with PM-1006-SS fasteners at the holes previously drilled in fabrication.
- The exterior corner cover will require E2-0051 bulb gaskets cut to the length of the mullion. Apply dabs of sealant to the bottom of the bulb gasket to adhere it to the mullion so that it will not slide out during unit installation. Do not overseal. Insert the gasket into the reglet at the cover.
- The 90° corner cover (E9-2740) will also require an E2-0110 spacer tape adhered the cover for one side of the corner. This will keep the cover from flexing too much. (The other corner half for the adjoining unit will not need this spacer tape as well.)

See **Details 19** for YWW 50 TU and **Detail 20** for YWW 60 TU.

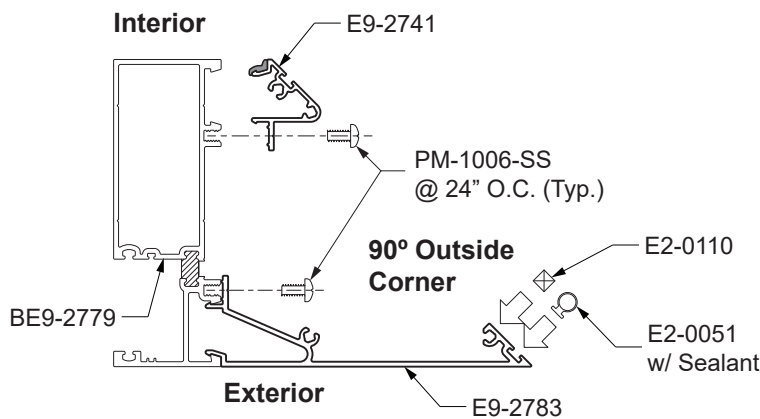

Detail 19
YWW 50 TU

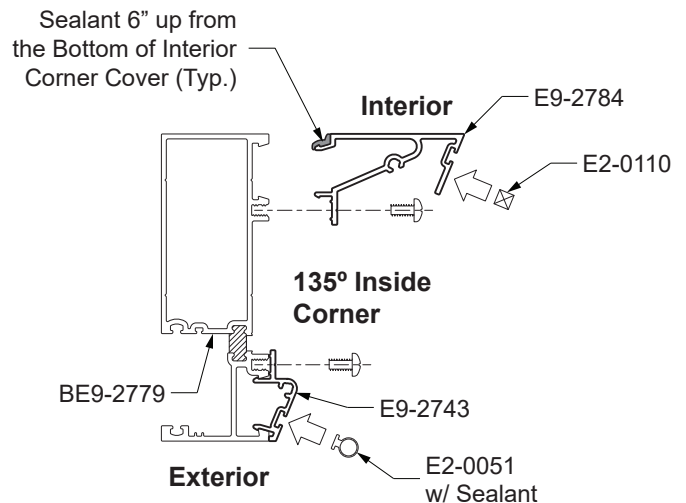
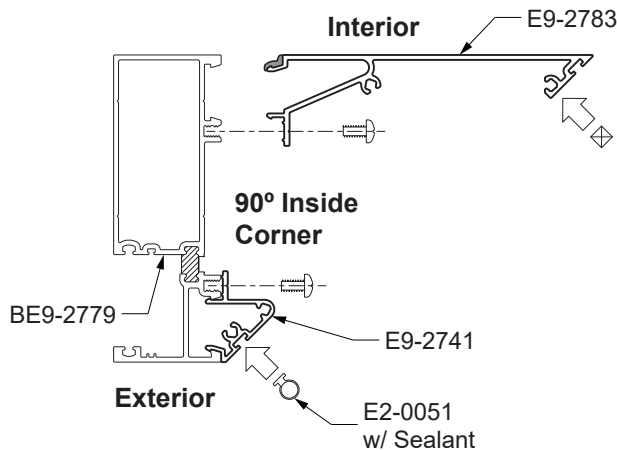
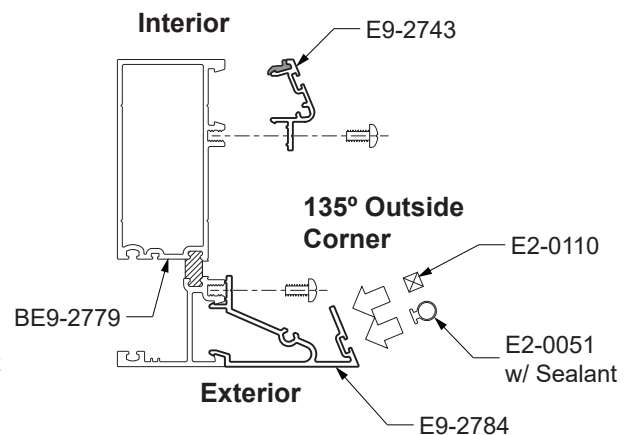

FRAME ASSEMBLY

**STEP 8 (Continued)
ASSEMBLE FRAME -- CORNER MULLION**

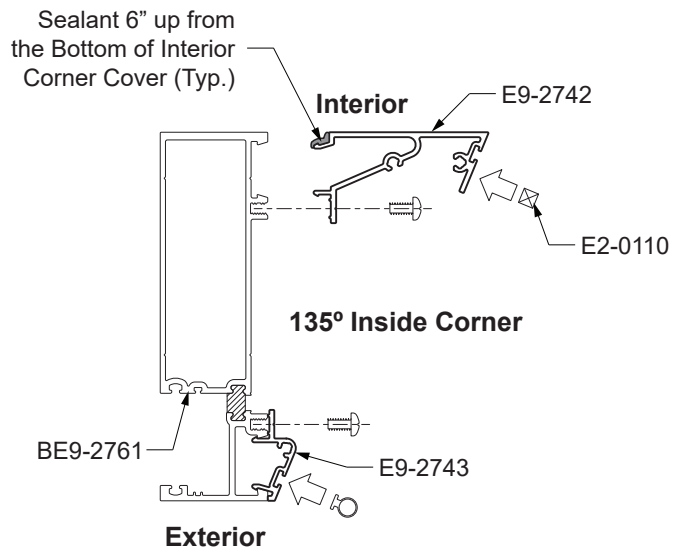
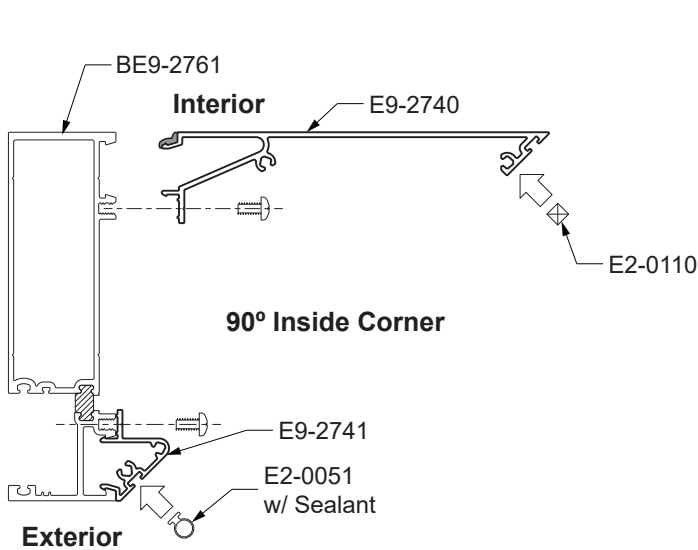
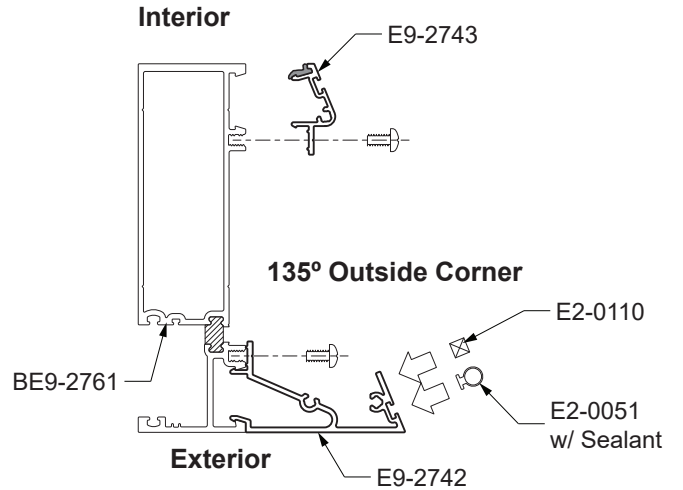
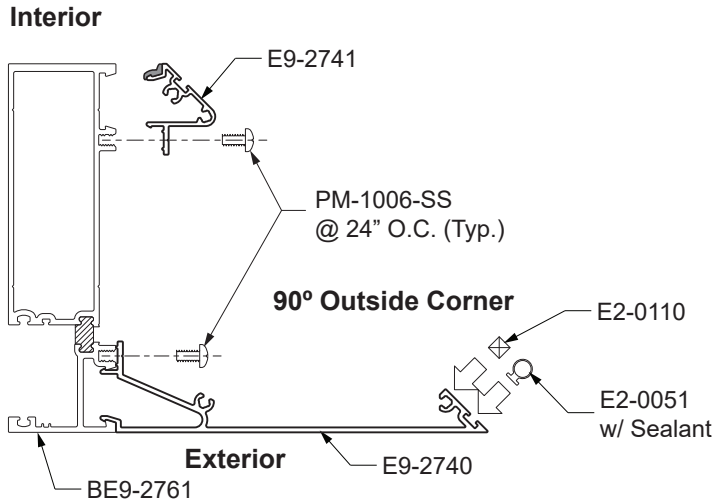

Detail 20
YWW 60 TU

FRAME ASSEMBLY

STEP 9 (Optional) SECURE UNIT FRAME

-It may be beneficial to attach bracing to the workspace against the outer edges of the mullions to keep the unit square during the remainder of the assembly process.

See **Detail 21**.

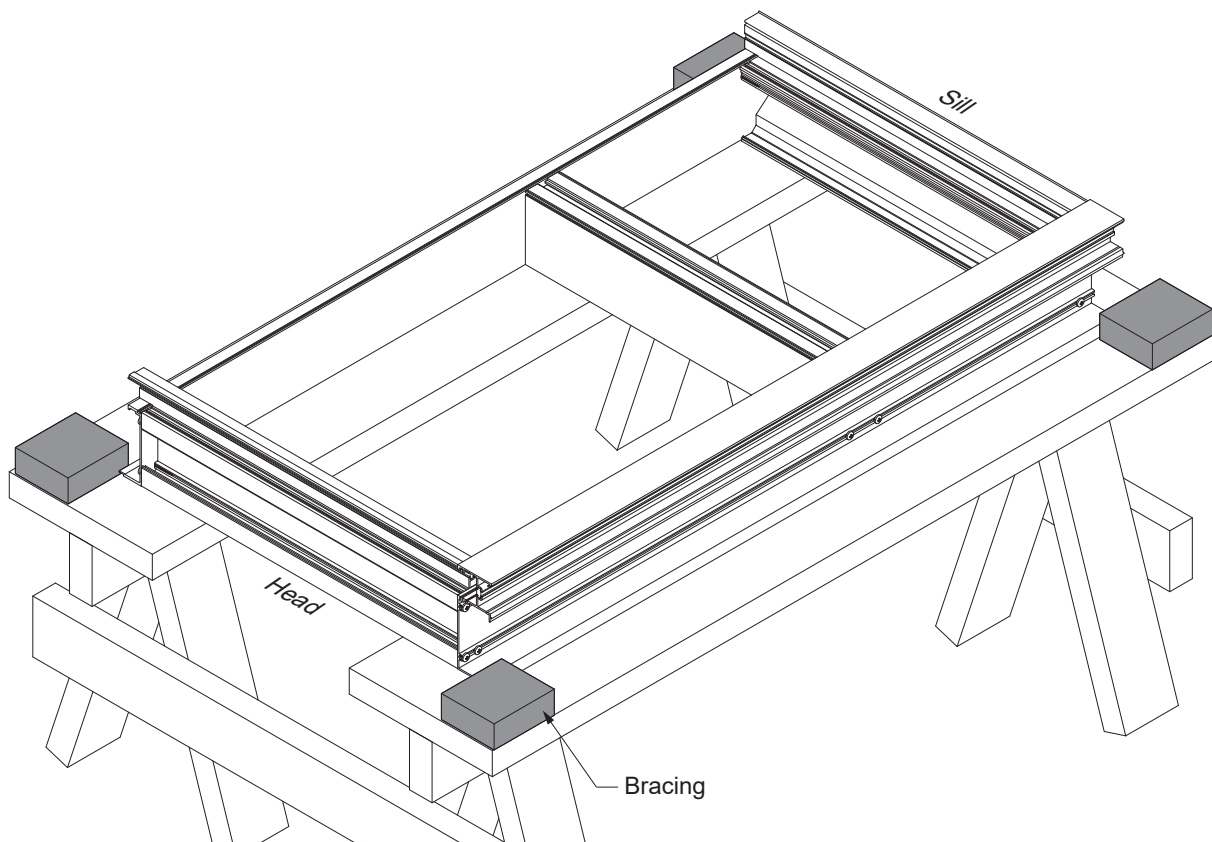

Detail 21

FRAME ASSEMBLY**STEP 10 (Optional)
INSTALL STEEL REINFORCING**

- Install steel reinforcing into the mullions and jambs as required by the P.E. calculations and or approved shop drawings.
- Take care that the fasteners do not interfere with the horizontals nor would be visible when the unit is installed.

See **Detail 22**.

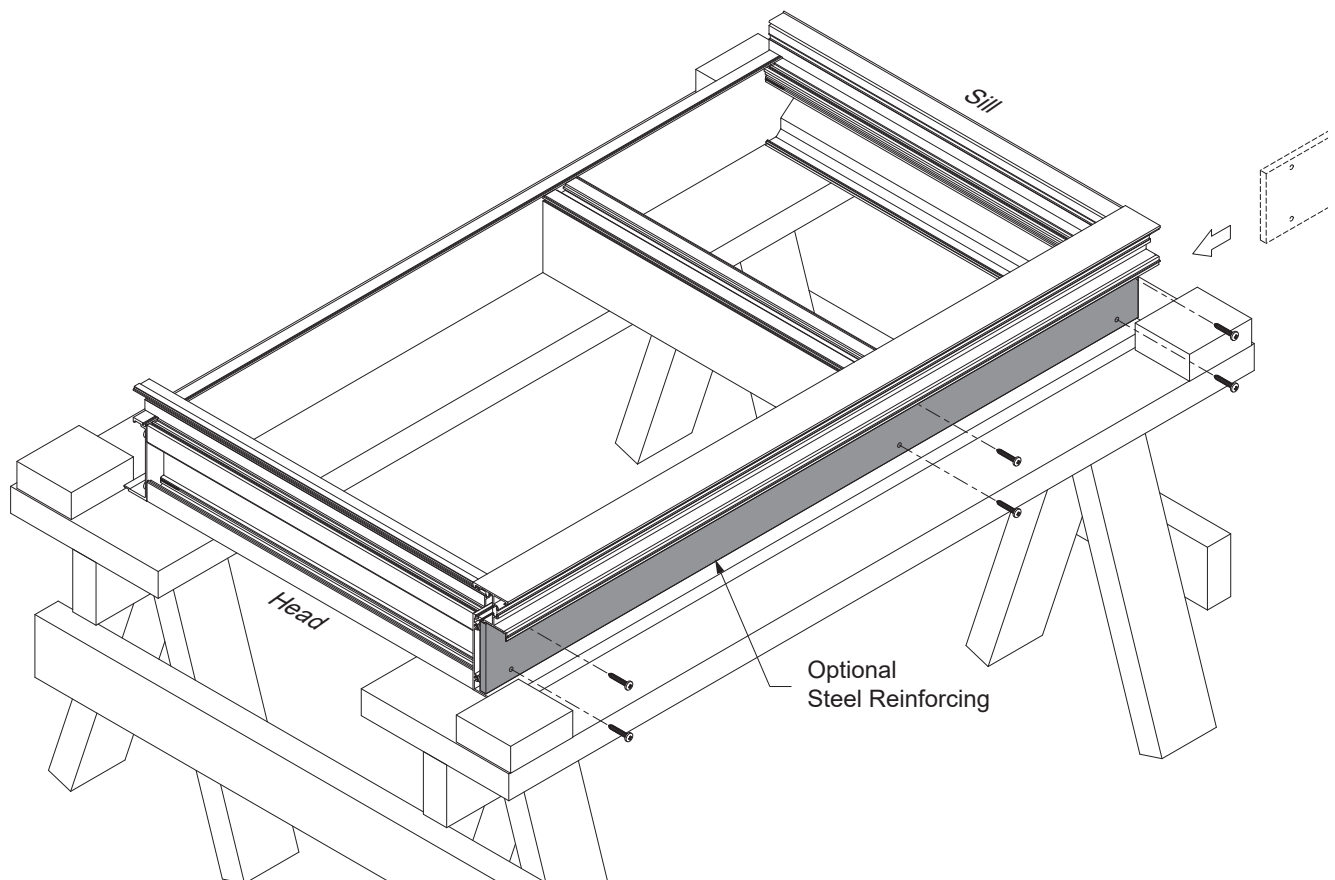

Detail 22

FRAME ASSEMBLY

STEP 11 INSTALL PERIMETER FILLERS

Install perimeter fillers into the jamb mullions and the head member.
-For the head, cut the E3-3664 pocket filler to horizontal daylight opening minus(-) 1/32" and snap it into the perimeter glazing pocket.

-If jamb strap anchors are used, install them into the jambs prior to installing perimeter fillers.

See **Detail 23**.

-At the jamb, cut the E3-3664 pocket filler to length of vertical and install it into the jamb.

-Cut the flat filler (E3-0032 for YWW 50 TU and E3-0023 for YWW 60 TU) to the length of the jamb, except where strap anchors would interfere. Snap the filler into place.

See **Detail 24**.

Note: E3-0023 is not required for heavy duty jamb mullion.

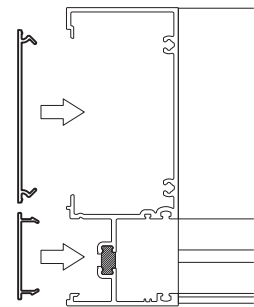

Detail 23

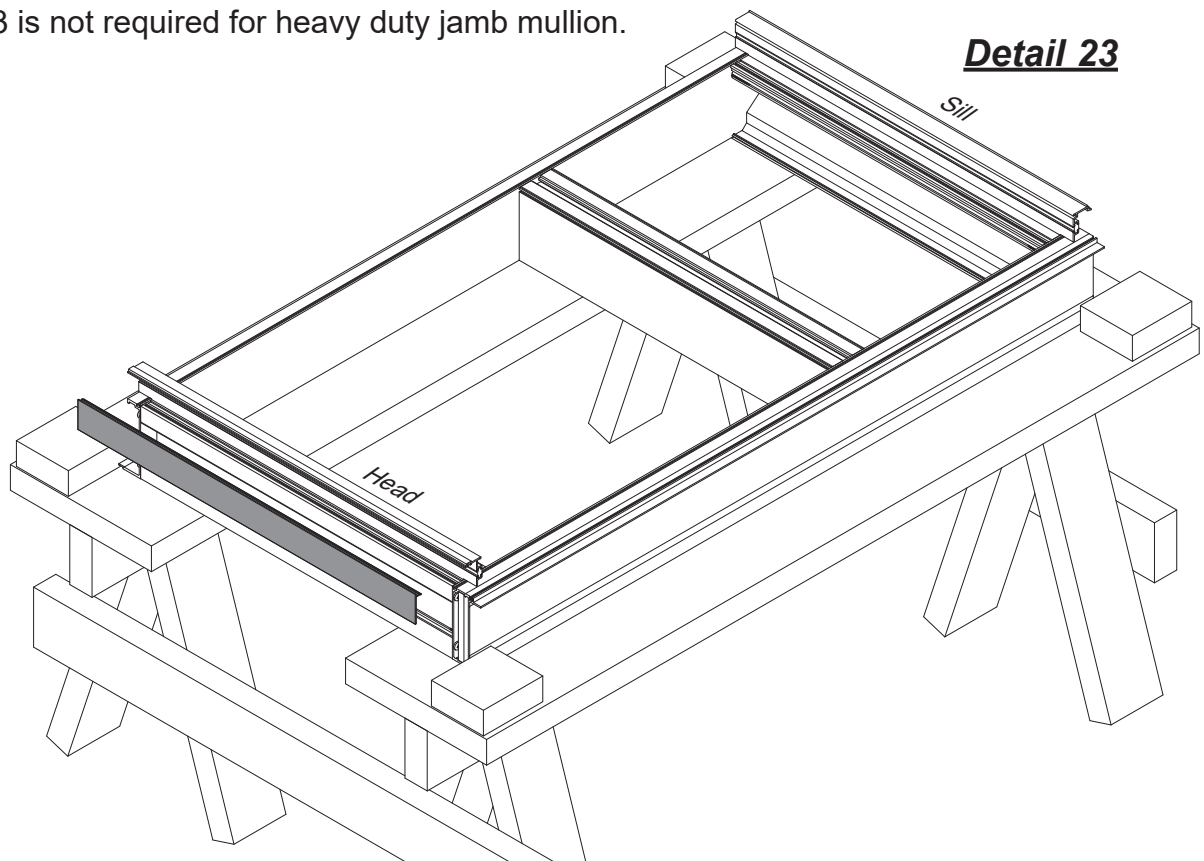

Detail 24

FRAME ASSEMBLY

**STEP 12
INSTALL FOAM PLUGS AT HEAD**

- Cut E2-0259 foam backer tape (maximum 1-1/4" long) to be installed at the head only. These will act as end caps for perimeter backer rods and sealant.
- Peel the adhesive tape from the foam and adhere it the mullion as shown in **Detail 25**. The foam can be easily compressed around physical obstacles in the assembled verticals.
- In the case where steel reinforcing is present at the head, the foam plugs may be adhered to the steel.

Note: For best adhesion, make sure the contact surfaces of the verticals and or steel members are clean and dry.

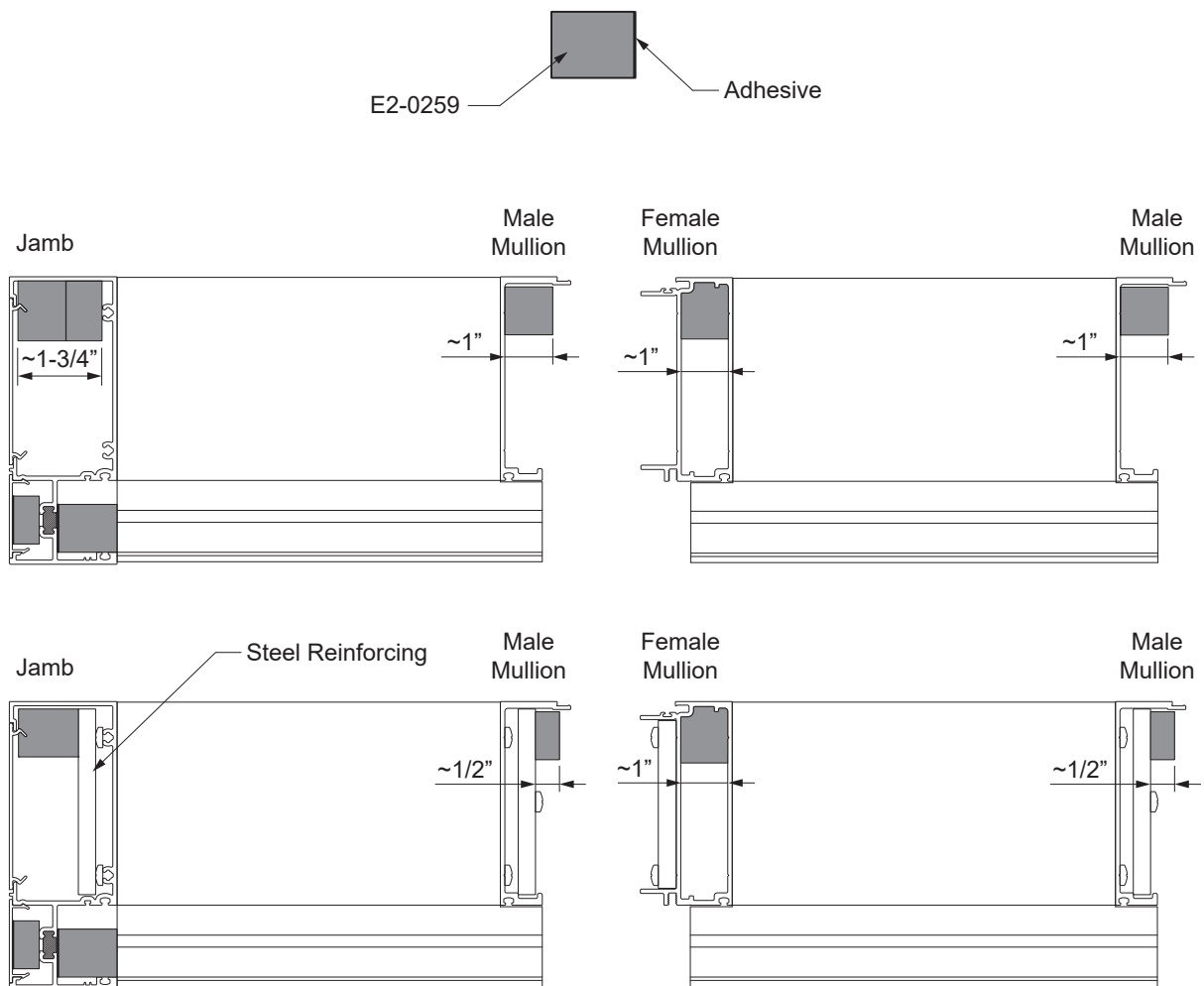

Detail 25

FRAME ASSEMBLY

STEP 13 INSTALL WEATHER SEAL

Weather seal gaskets (E2-7010) are installed in the female mullion only.

-Cut the weather seal gasket to length of the vertical plus(+) 3", and install into the interior reglet of the male mullion in the proper orientation as shown in **Detail 26**.

-Apply dabs of sealant to the bottom of the weather seal gasket to adhere it to the mullion so that it will not slide out during unit installation. Do not overseal. Too much silicone will deter mullion engagement.

-Trim the weather seal gasket after shrinkage.

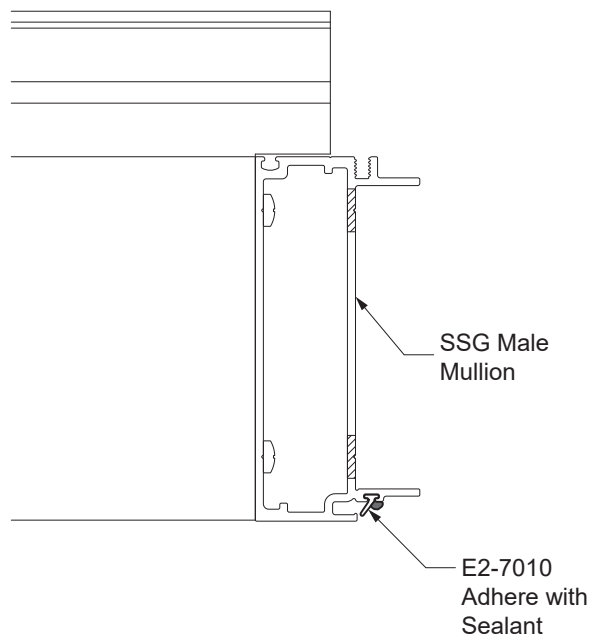

Detail 26

FRAME ASSEMBLY

**STEP 14
INSTALL INTERIOR GLAZING GASKETS**

-Using a small brush, clean out any dirt that may have accumulated in the gasket reglets.

Vertical glazing gaskets must be installed first:

- Cut vertical gaskets to the Daylight Opening plus(+) 3/4" plus(+) an additional 1/4" for each foot of length. For E2-0541 only, notch the ends of the vertical gasket as shown.
- Insert the gasket into the reglets at each end first; then insert the gasket at the midpoint of the opening.
- Push the gasket into the reglet starting at the midpoint and work towards each end.

See **Detail 27**.

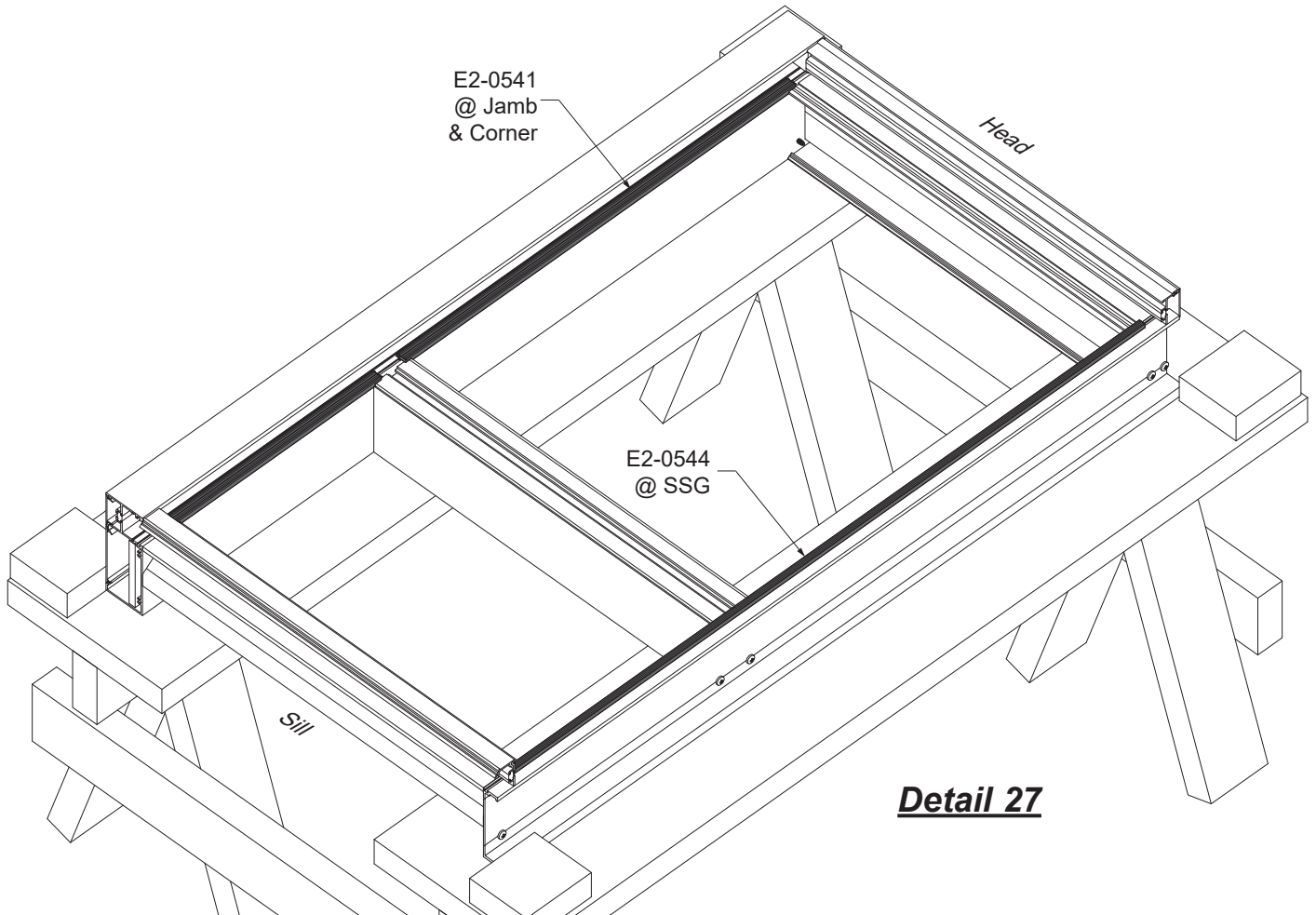
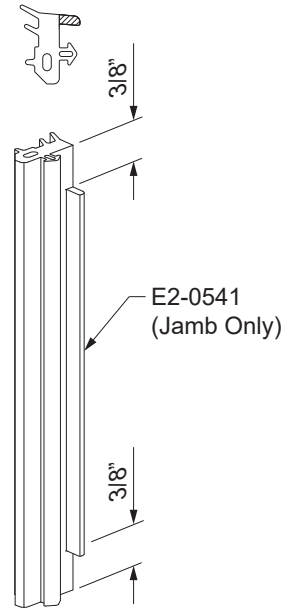

FRAME ASSEMBLY

STEP 14 (Continued)
INSTALL INTERIOR GLAZING GASKETS

Install horizontal glazing gaskets next:

- Cut horizontal glazing gaskets to Daylight Opening plus(+) 1/4" for each foot of length.
- Apply sealant to each end of the horizontal glazing gasket prior to inserting into the reglet.
- Insert the gasket into the reglet at each end first; then insert the gasket at the midpoint of the opening.
- Push the gasket into the reglet starting at each end and work towards the midpoint.
- Tool the excess sealant at the gasket corners to ensure a watertight seal.

See **Detail 28**.

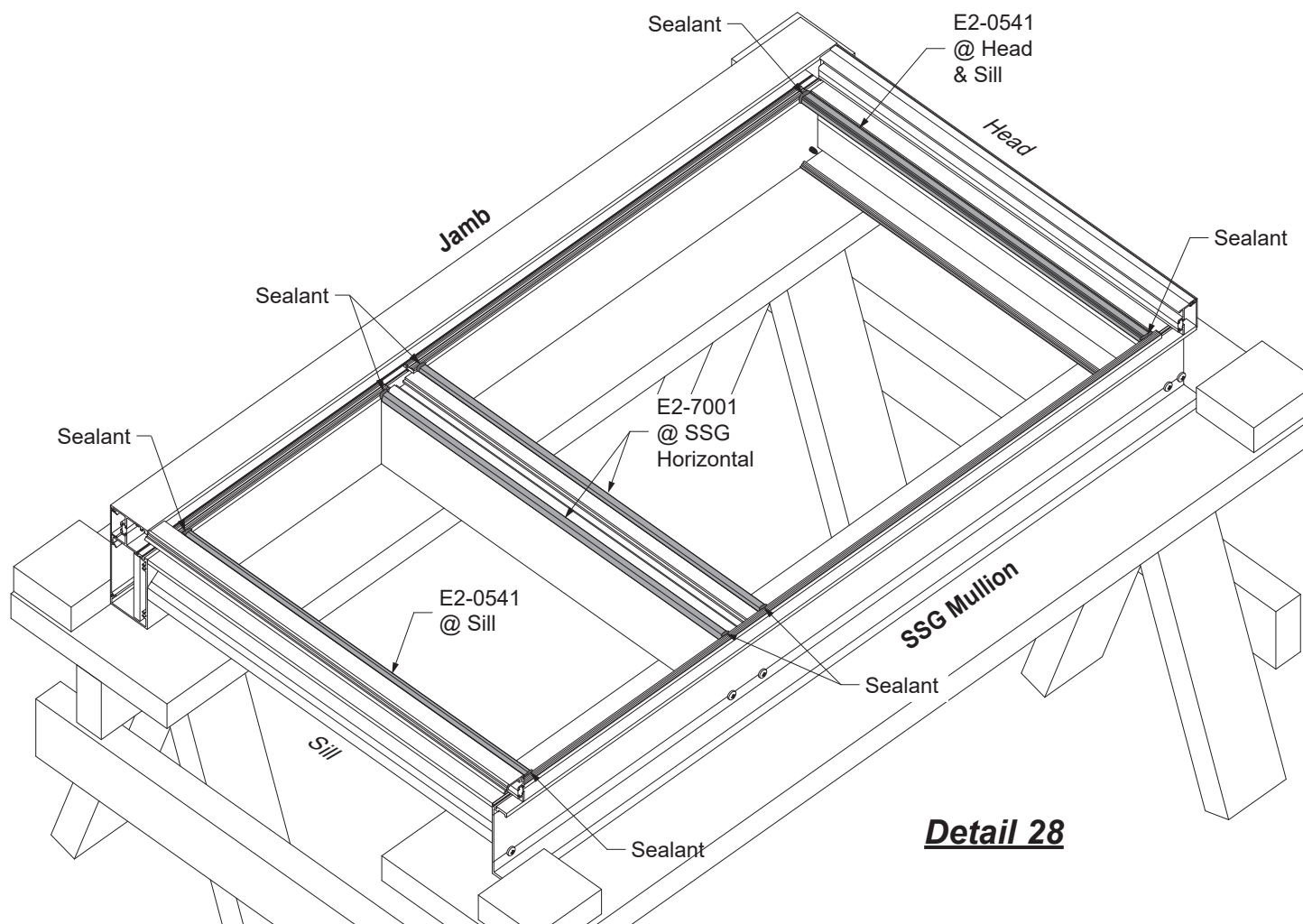



Detail 28

GLAZING

**STEP 15
INSTALL SETTING / SIDE BLOCKS**

-Apply setting blocks into the glazing pockets for every sill and intermediate horizontal as shown in **Detail 29** at quarter points at every daylight opening. Adhere the setting blocks with sealant. For jamb mullions, add E2-0628 setting blocks as shown (adhere with sealant).

| | | |
|---------------------|---|---------------------|
| E2-0150 |  | For Sill Members |
| E2-0628 |  | For Jamb |
| E1-3545/ E2-0224 |  | For SSG Horizontals |

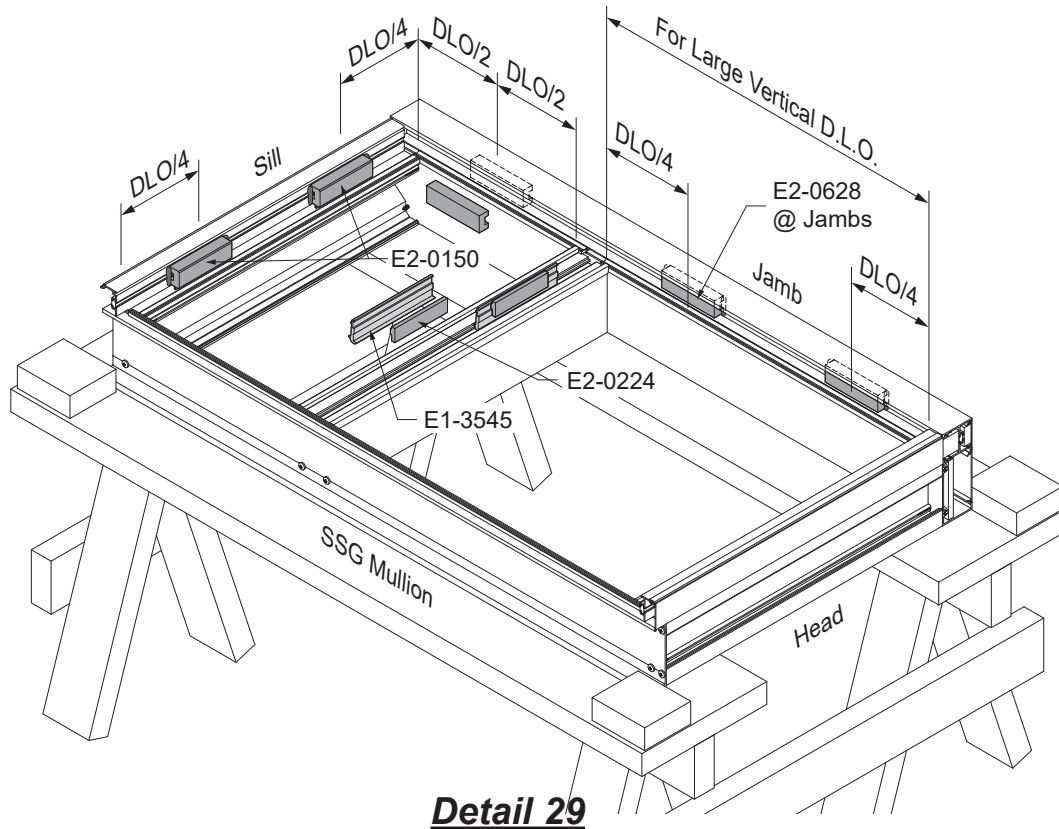

Packing/Shipping Notes for Jamb Units:
If packing units horizontally, ship with jamb side down.

GLAZING

**STEP 16
INSTALL GLASS**

Determine the glass size based upon the vertical and horizontal conditions illustrated in **Detail 29**.

Ensure the unit is square before glazing

-Install the glass lites into the daylight openings.
Position the glass lites ensuring the proper glass bites all around and tight against the setting blocks. Align the exterior edge of the glass with the edge of the female mullion half and the V-groove on the male mullion half

See **Details 30, 31, & 32**.

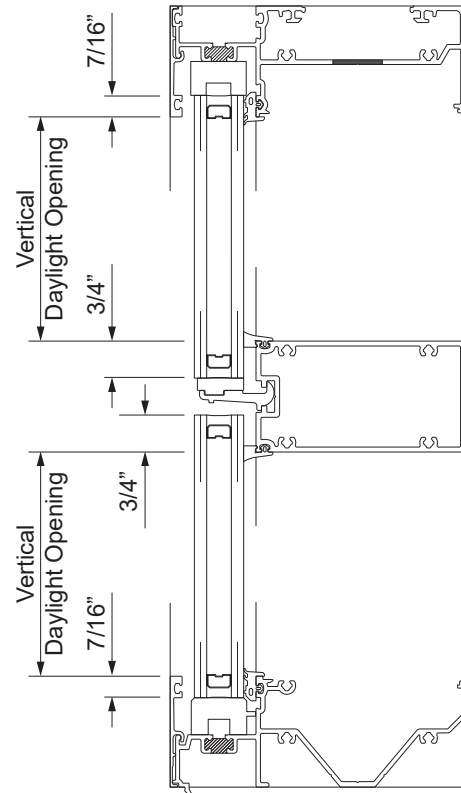

Detail 30

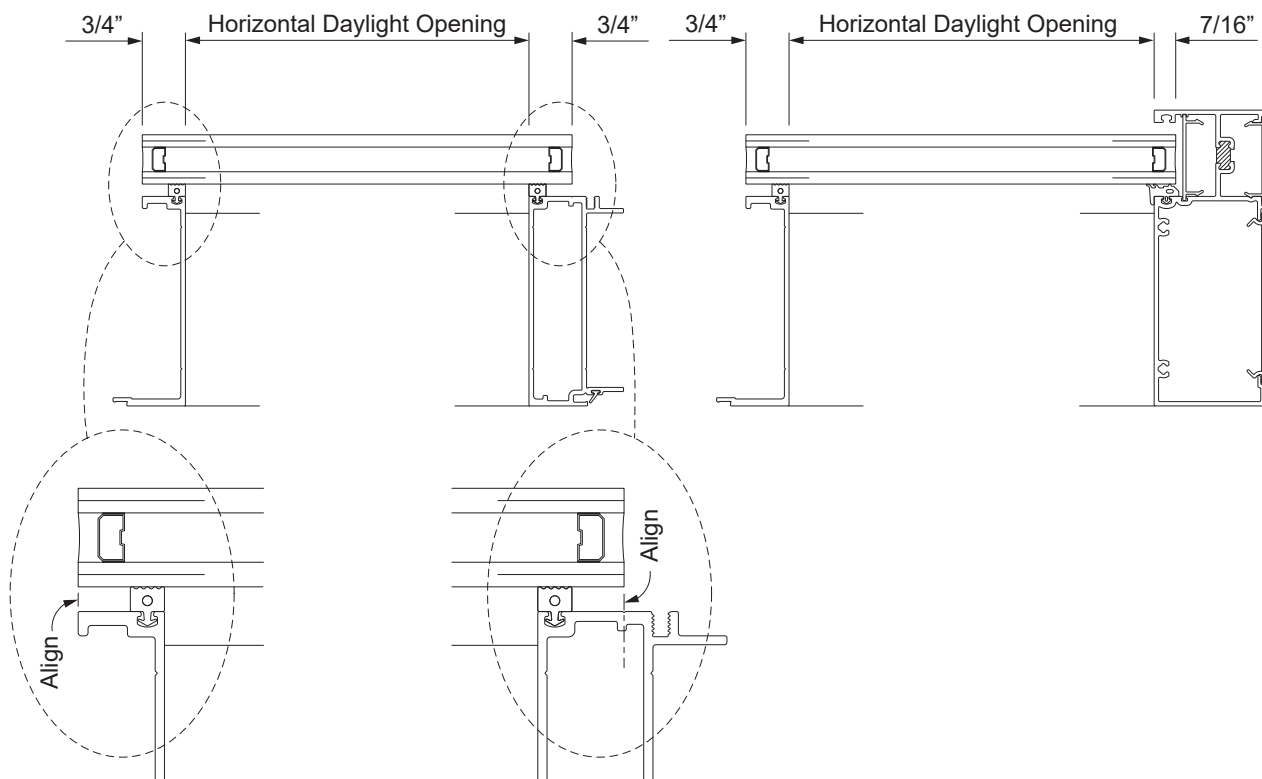

GLAZING

**STEP 16 (Continued)
INSTALL GLASS**

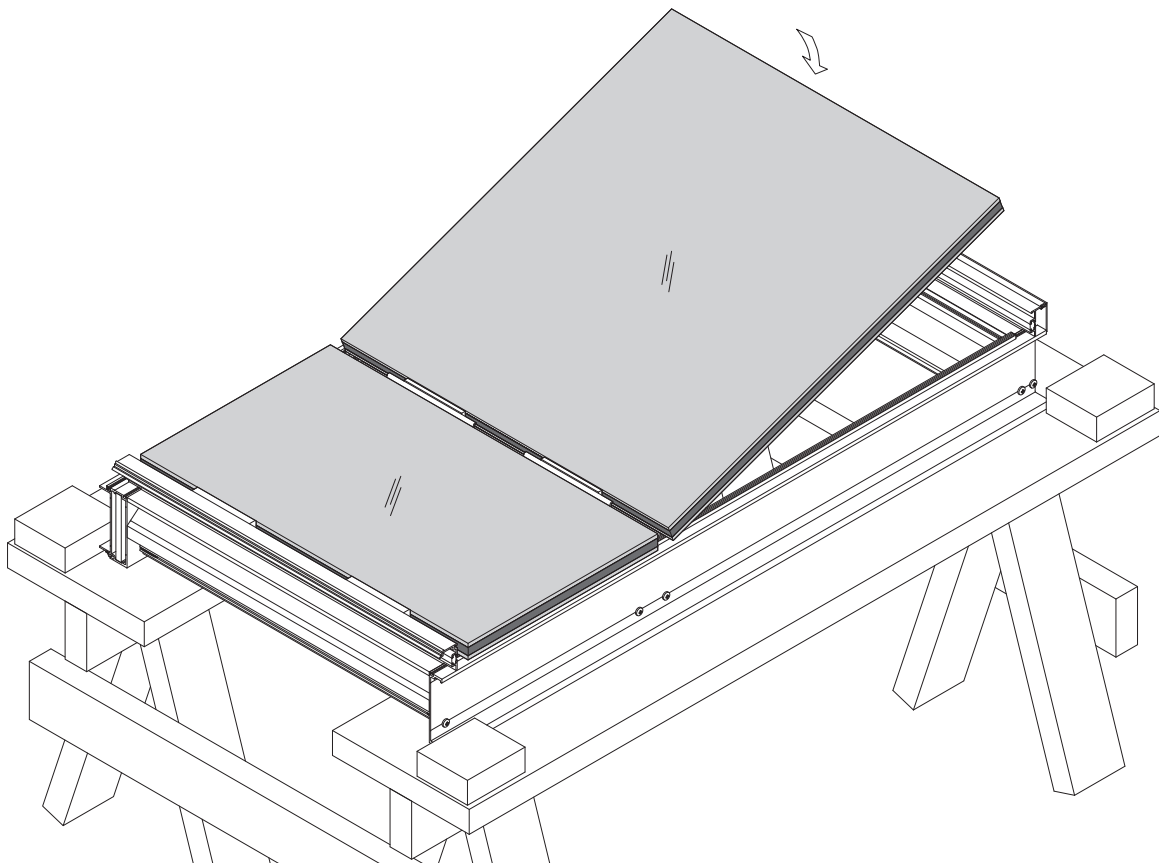

Detail 31
Intermediate Unit

GLAZING

STEP 16 (Continued)
INSTALL GLASS

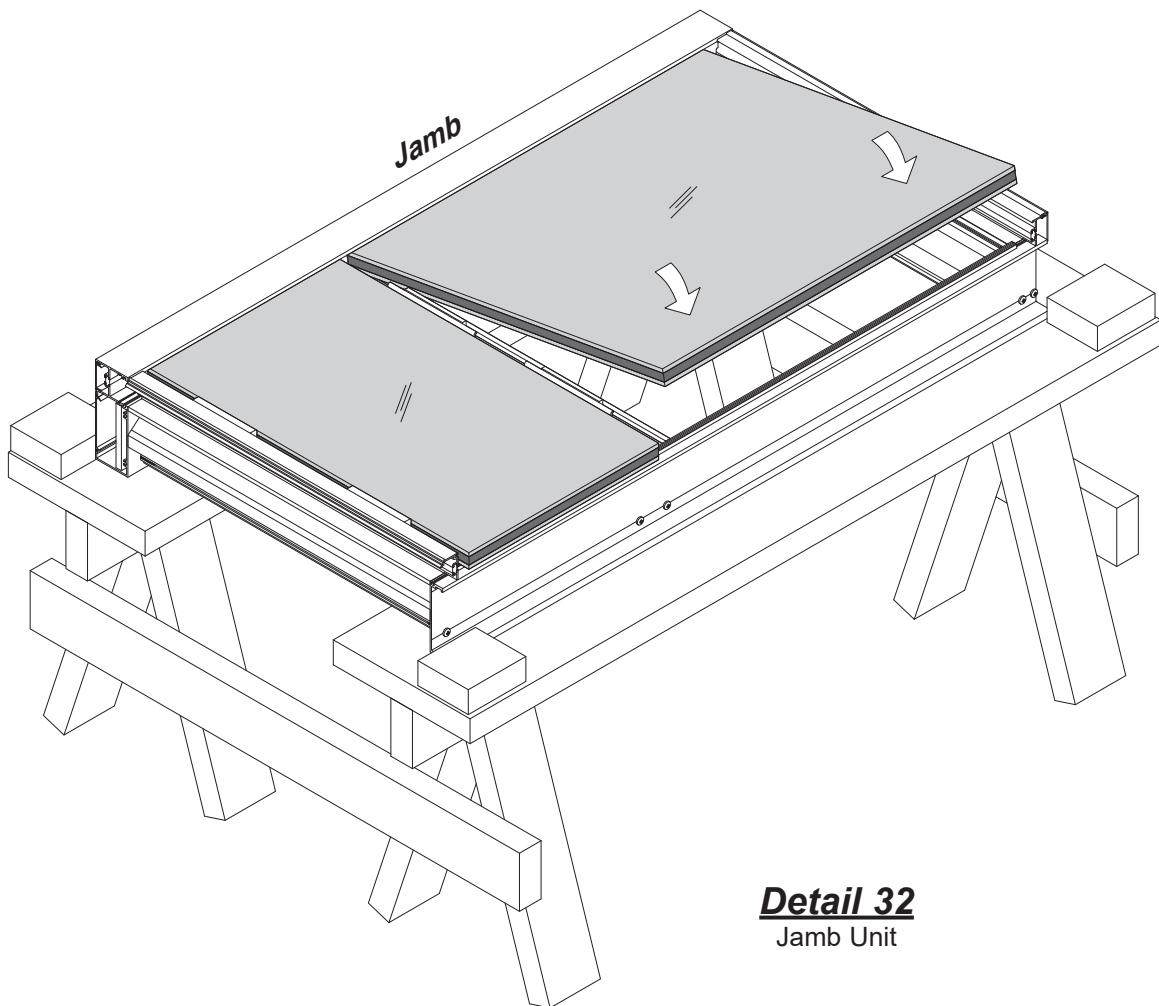

Detail 32
Jamb Unit

GLAZING**STEP 17
INSTALL SETTING BLOCKS AT HEAD**

-Adhere E2-0628 setting blocks with silicone to the frame at the topside of each lite at each end of the daylight opening. Be sure to set the inside face of the setting block flush with the glass and in the proper orientation as shown in **Detail 33**. This will keep the glass from shifting as the unit is raised for installation. If the glass is oversized, trim the blocks to fit.

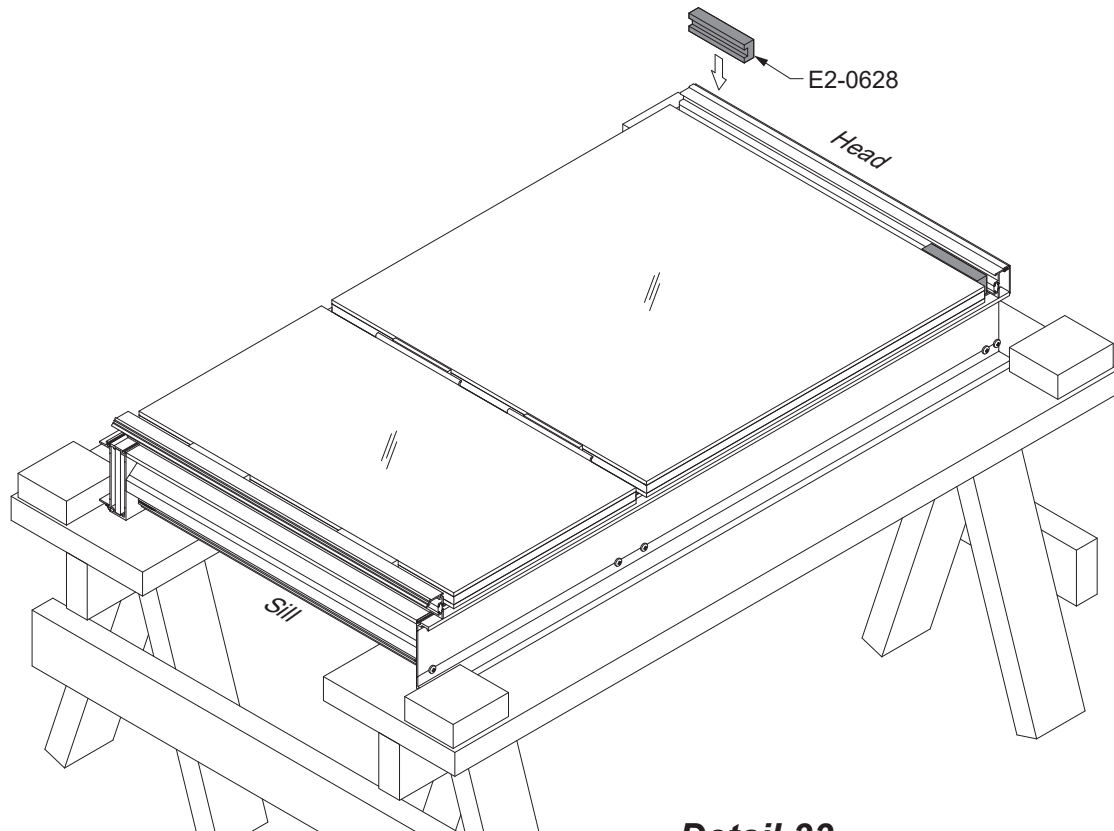

Detail 33
Dry Glazing Only

GLAZING

**STEP 18
SEAL GLASS TO FRAME**

-Apply structural silicone sealant to the gap between the glass and the frame, first at the intermediate SSG horizontals as shown in **Detail 34**.

Note: the setting blocks/chairs may need to be moved temporarily to properly seal the glass to the horizontals, and then relocated back to their intended positions once finished.

-Apply the sealant to the remaining perimeter of the glass as shown in See **Detail 35**.

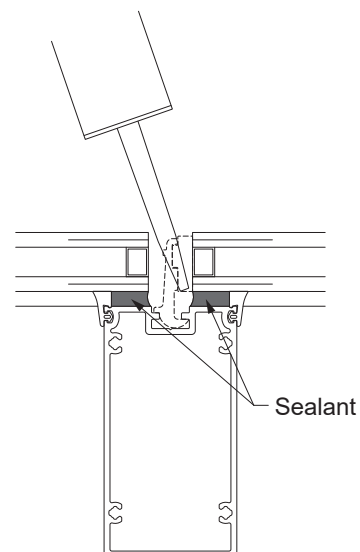

Detail 34

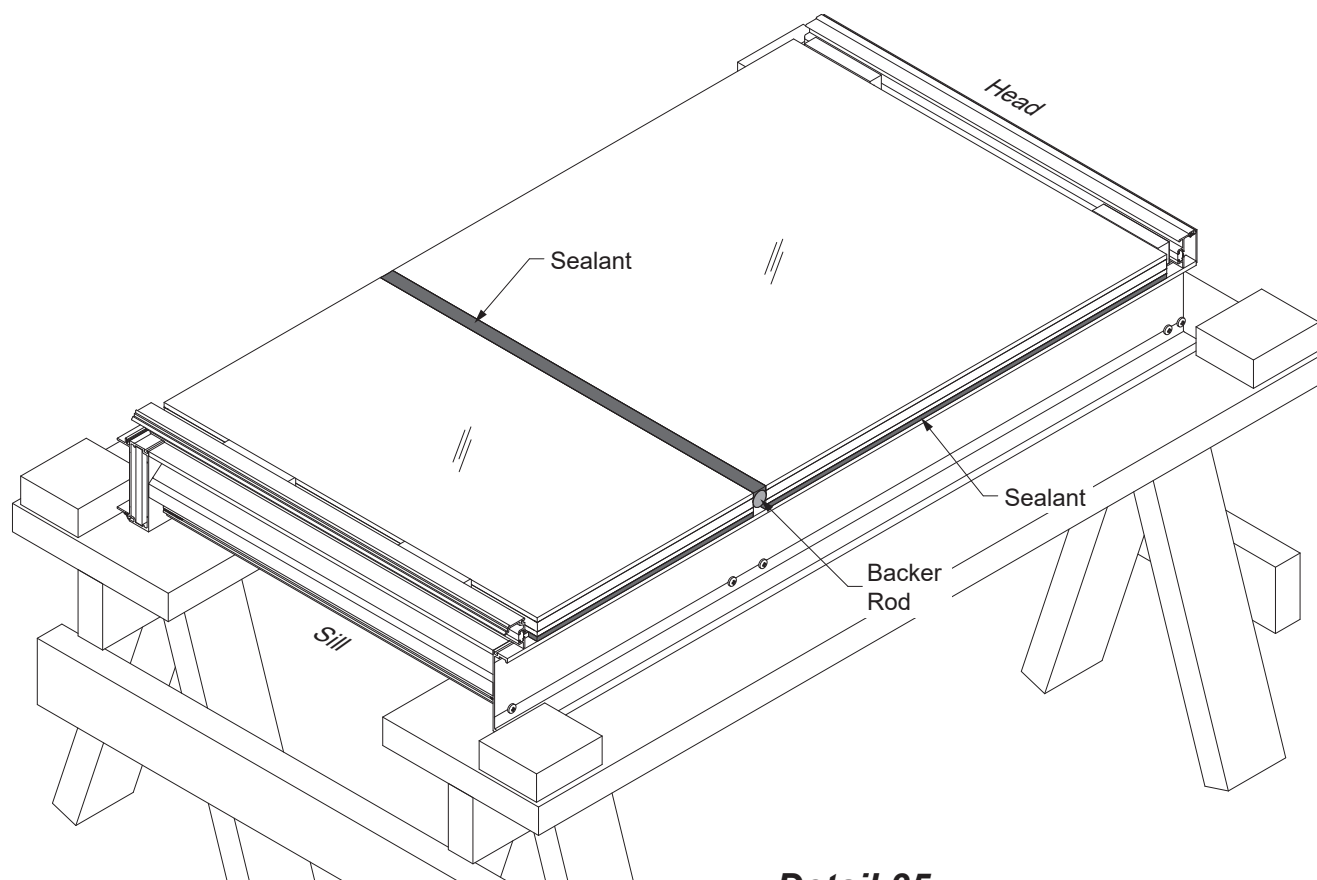

Detail 35

GLAZING

**STEP 19
INSTALL GLASS STOPS (FOR JAMB UNITS)**

- Apply sealant to the top corners of the jambs where the E2-1715 glass stops will be set against.
- Set the E9-1715 glass stops in place at the head and sill. Insert a 2" long section of E2-0542 gasket to temporarily hold the glass in place.
- Tool sealant at intersection of the glass stop to the vertical mullion.

See **Detail 36**.

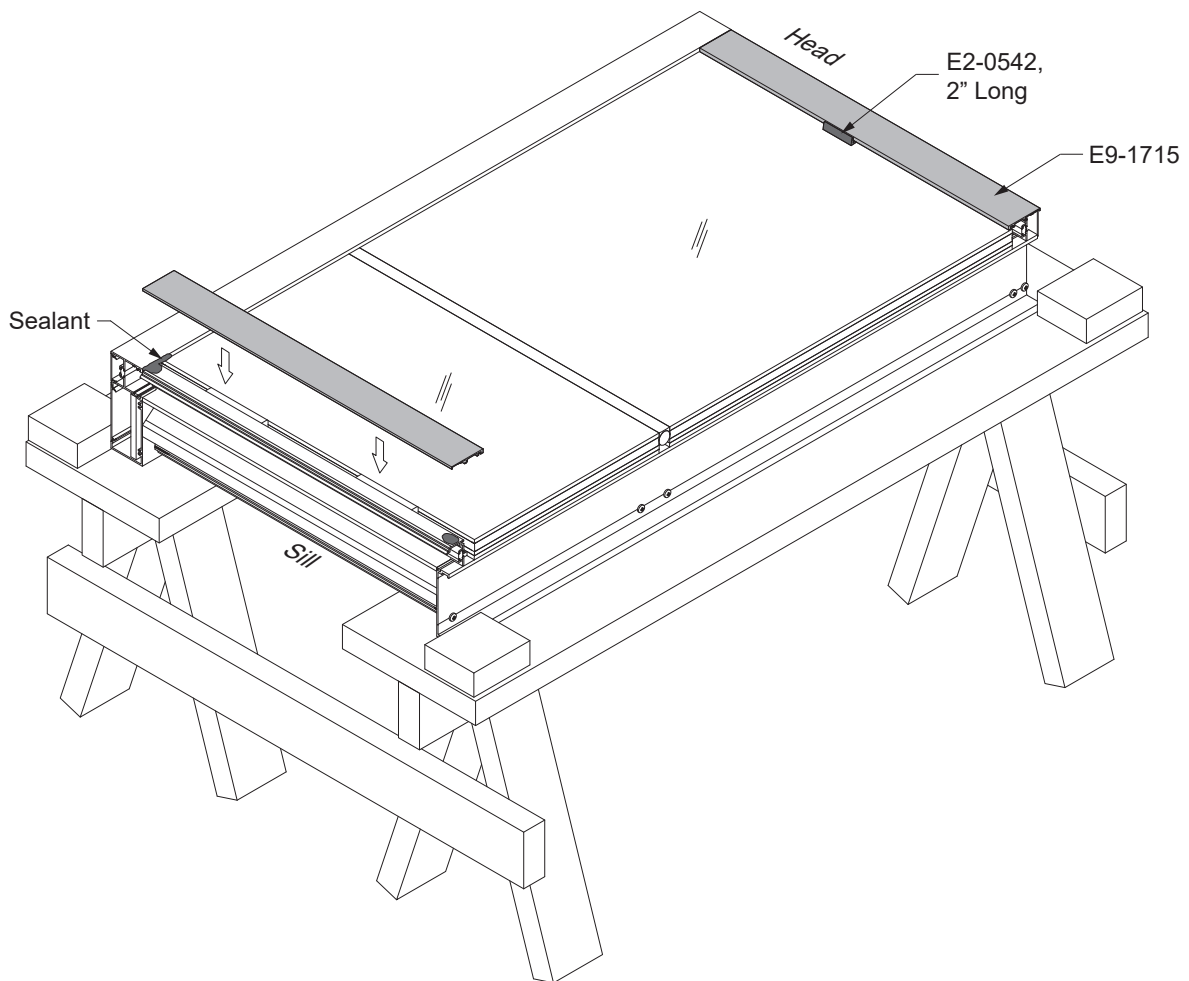

Detail 36

GLAZING

STEP 19 (Continued) INSTALL GLASS STOPS (FOR INTERMEDIATE UNITS)

-Installation of the exterior glass stops is similar to that for the jamb unit except the glass stop is centered on the horizontal daylight opening and sealant is not applied to the corners.

See **Detail 37**.

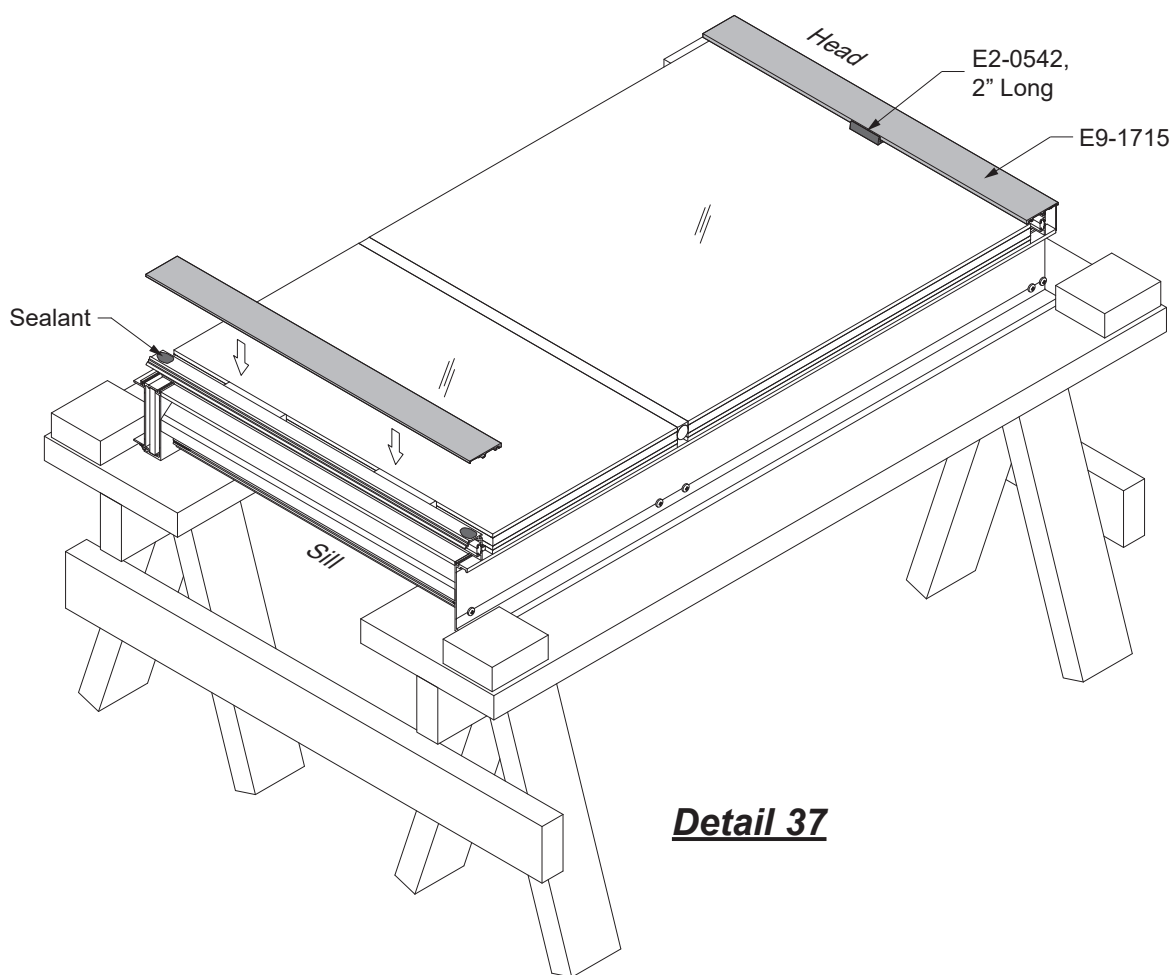

Detail 37

GLAZING

**STEP 20
INSTALL SSG RAINSCREEN GASKET**

-Cut the E2-0540 SSG rainscreen gasket to frame height minus (-) 4-1/2". Apply sealant to both ends where the gasket engages the mullion as shown below in **Detail 38**. Insert the gasket into the mullion, centered vertically on the framing unit. A screen roller tool and lubricant is recommended.

Note: Ensure that the distance between the end of frame and the end of the rainscreen gasket at each end is 2-1/4". Distances shorter than that will create difficulty for installing the joint plugs at the head and sill later on **Page 41**.

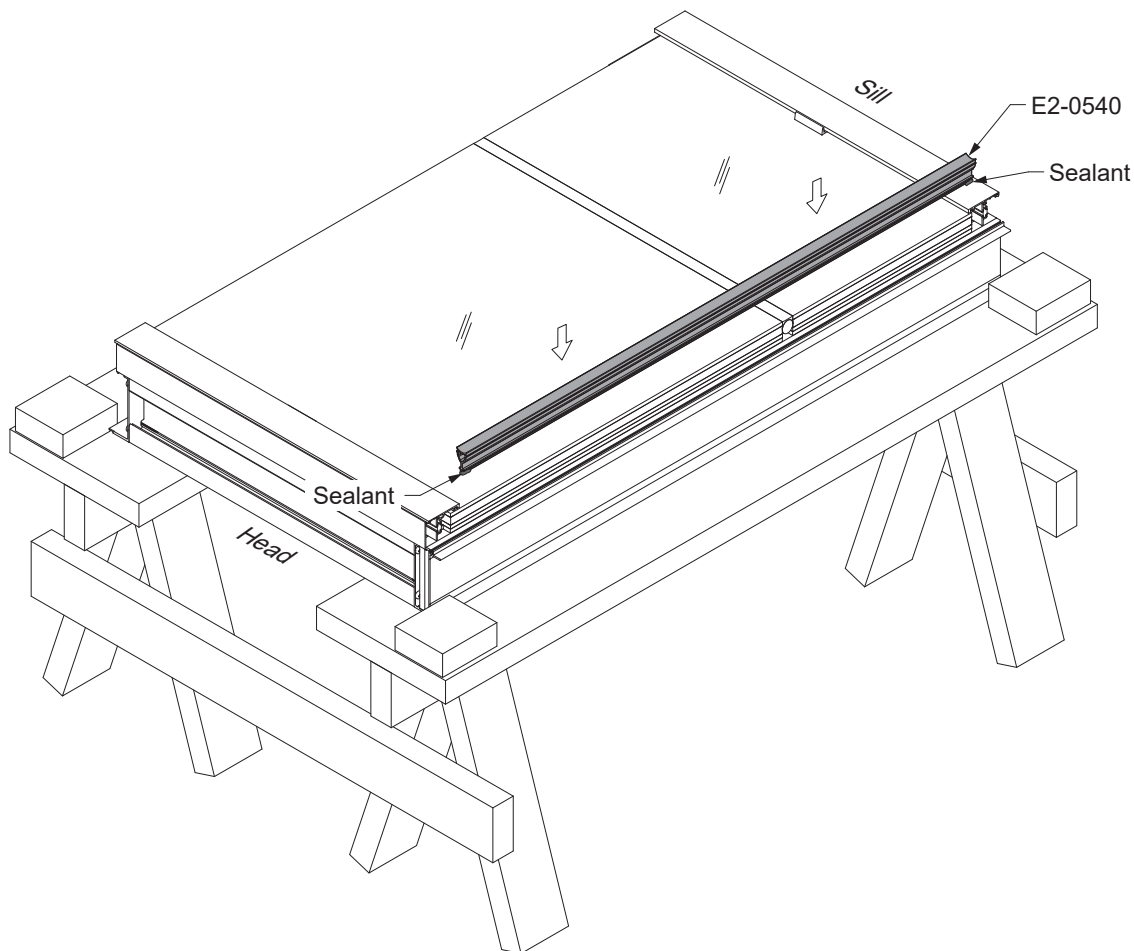

Detail 38

GLAZING

**STEP 21
INSTALL VERTICAL WEDGE GASKET (FOR JAMB UNIT)**

- Cut the E2-0542 wedge gasket to frame height minus (-) 3-3/4".
- Notch each end of the gasket by 3/8" as shown in **Detail 39**.
- Insert the gasket into the exterior jamb glazing pocket, starting at the ends first and working towards the midpoint as shown in **Detail 40**.

Detail 39

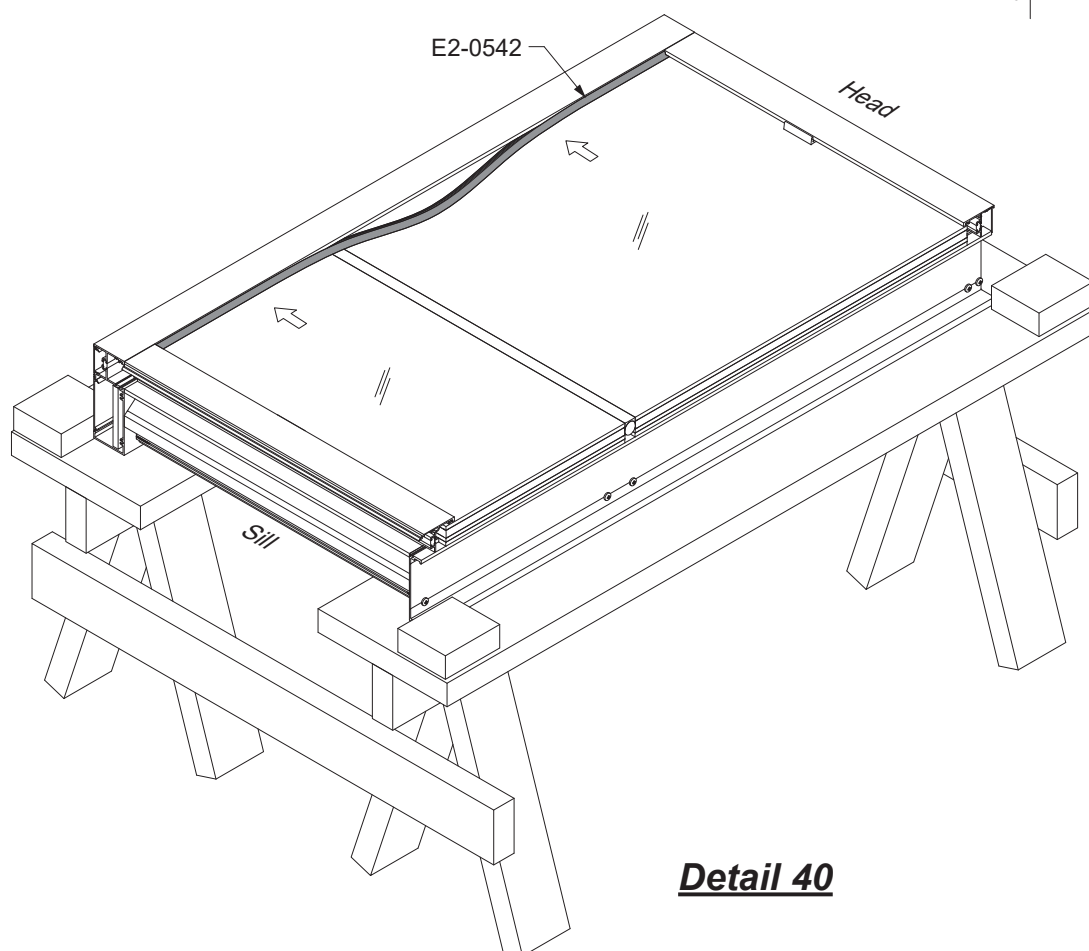

Detail 40

GLAZING**STEP 21 (Continued)****INSTALL HORIZONTAL WEDGE GASKET**

- Cut the E2-0542 wedge gasket to the length of the glass stops.
- For jamb units apply sealant to the end of the wedge gasket where it meets the vertical gasket.
- Insert the wedge gasket into the exterior glazing pocket, centered on intermediate units, and tight against the jamb gasket at jamb units.

See **Detail 41**.

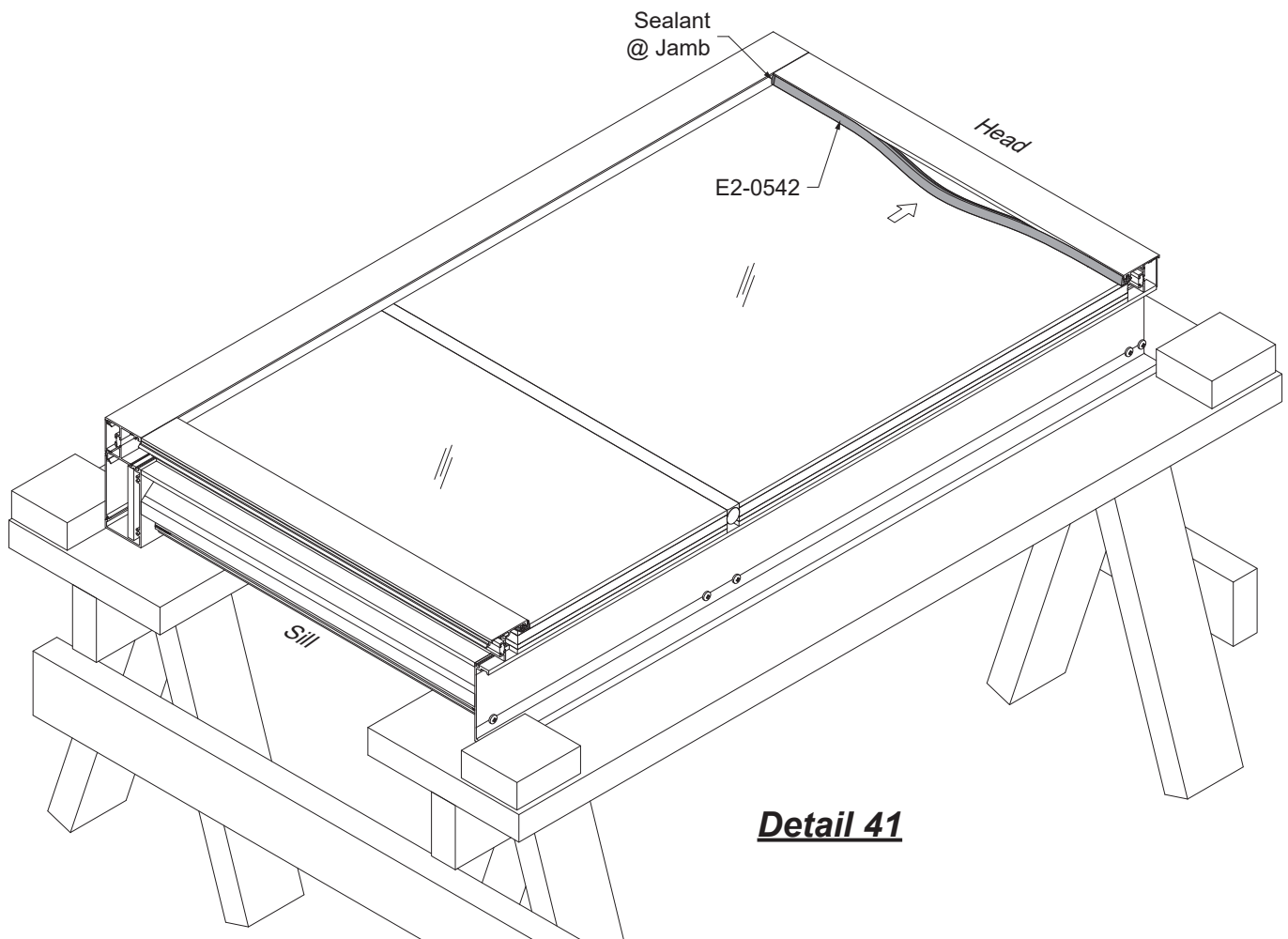

GLAZING

STEP 22 INSTALL JOINT PLUGS

- Fill the head and sill glazing pockets at the SSG mullion with sealant, giving the E2-9802 joint plugs a surface to adhere to.
- Adhere the joint plugs to the top and bottom of the unit at the SSG mullion, flush with the exterior glass stop. Tape the joint plugs in place until the sealant is cured.

See **Detail 42**.

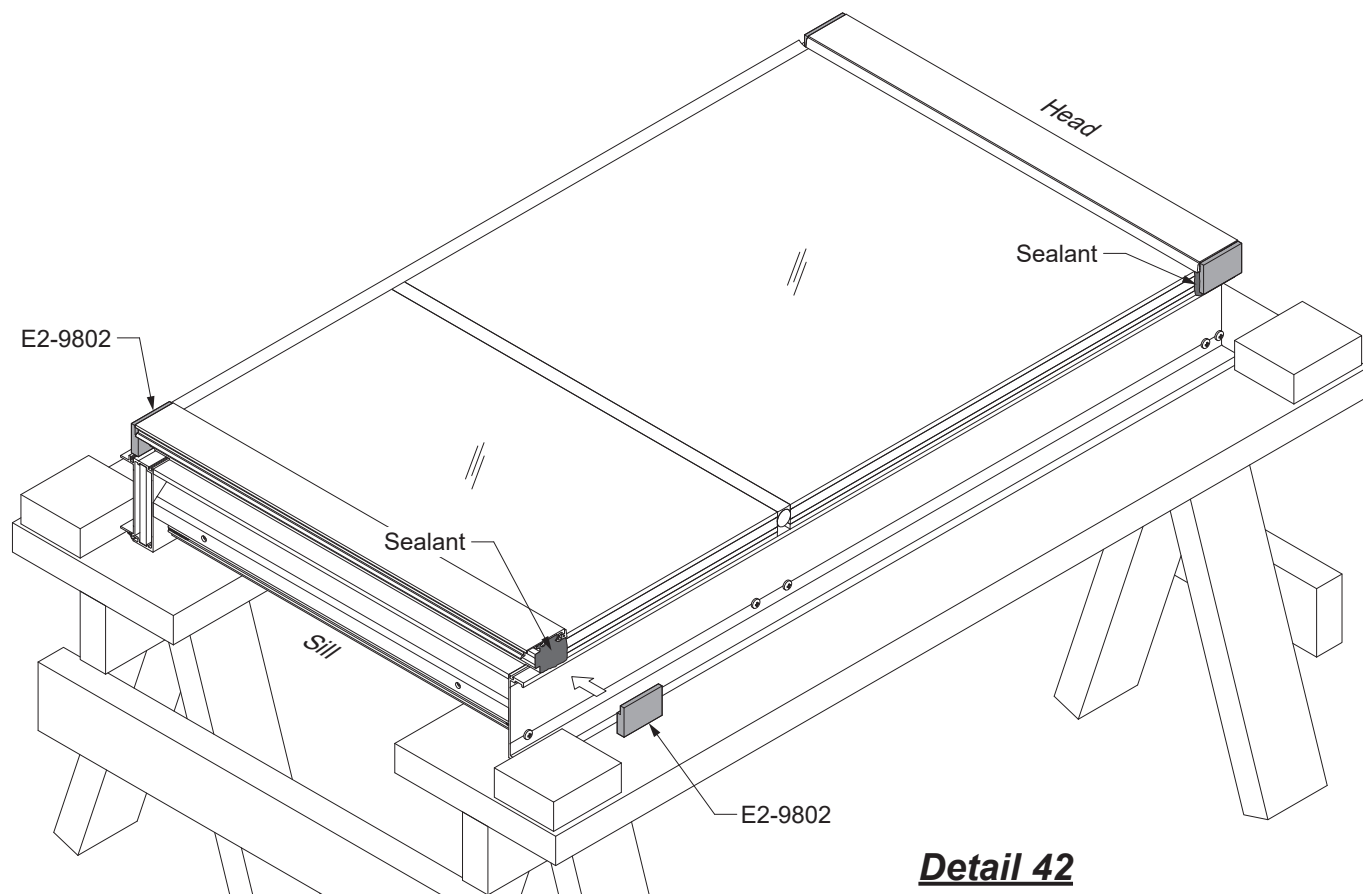

Detail 42

FRAME INSTALLATION

**STEP 23
INSTALL SILL FLASHING END DAMS**

-Bend the end dam tab left or right 90 degrees in order to “hand” the end dam for the left or right end of the flashing.

See **Detail 43**.

- Clean all joint surfaces using cleaner approved by sealant manufacturer.
- Apply sealant to the end of the sill flashing as shown in **Detail 44**.
- Slide the tab into the top portion of the sill flashing.
- Tap the tab into place with a small tool until the end dam is snug against the end of the flashing.
- Fasten the end dam to the sill flashing with three UA-1212 screws, starting at the back, followed by the front as shown in **Detail 44**.
- Tool sealant along the joint between the end dam and the sill flashing as shown in **Detail 45**.

E1-1141 for YWW 50 TU
E1-1142 for YWW 60 TU

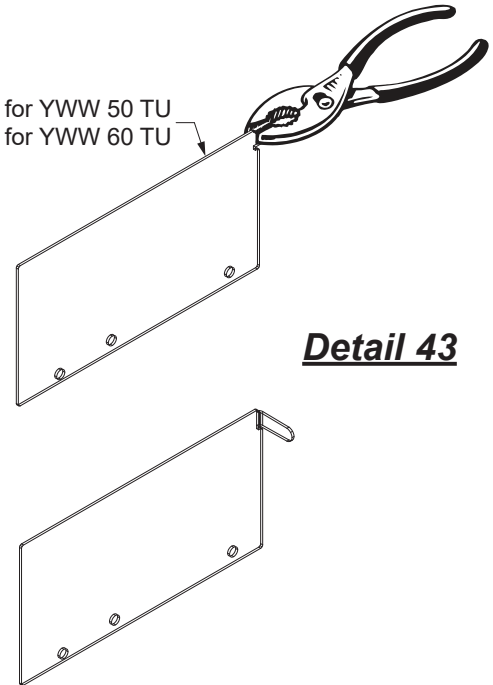

Detail 43

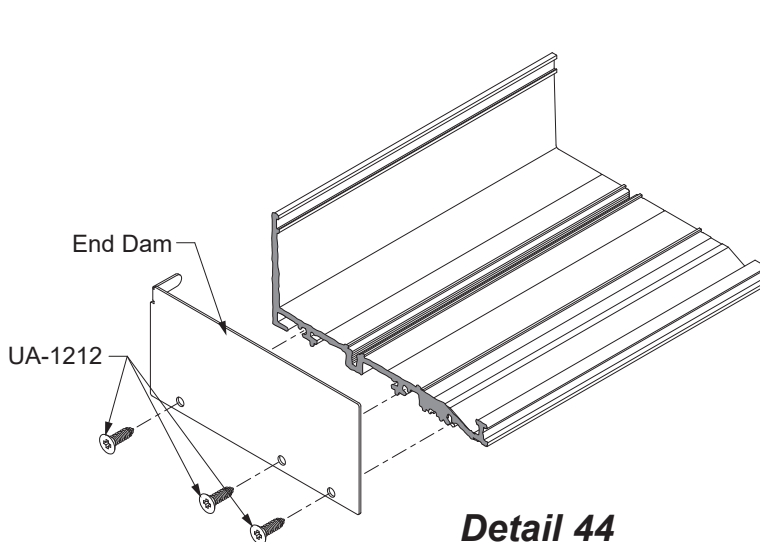

Detail 44

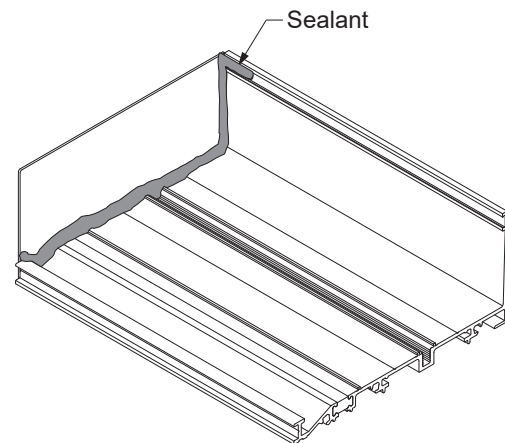

Detail 45

FRAME INSTALLATION

STEP 23A
INSTALL SILL FLASHING END DAMS FOR SLAB
EDGE COVER

- Sill flashings with slab edge covers will require an aluminum plate adaptor E9-8222 to be attached prior to field installation.
- Insert (2) E2-0065 weathering gaskets cut to the length of the reglets on the adaptor.
- Slide the slab edge adaptor onto the sill flashing.

See **Detail 46**.

- Installation of the E1-1198 end dam is the same as illustrated in the previous page, except that the end of the installed slab edge adaptor will also require sealant.
- Fasten an E1-1196 end cap onto the slab edge assembly using an additional UA-1212 screw.

See **Detail 47**.

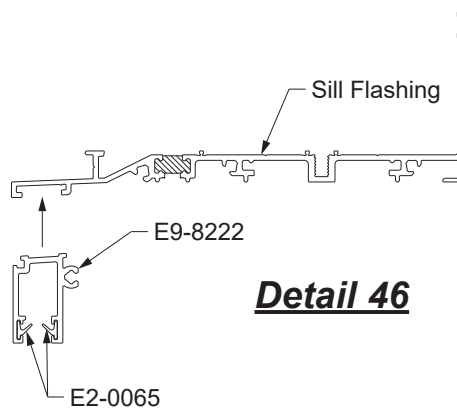

Detail 46

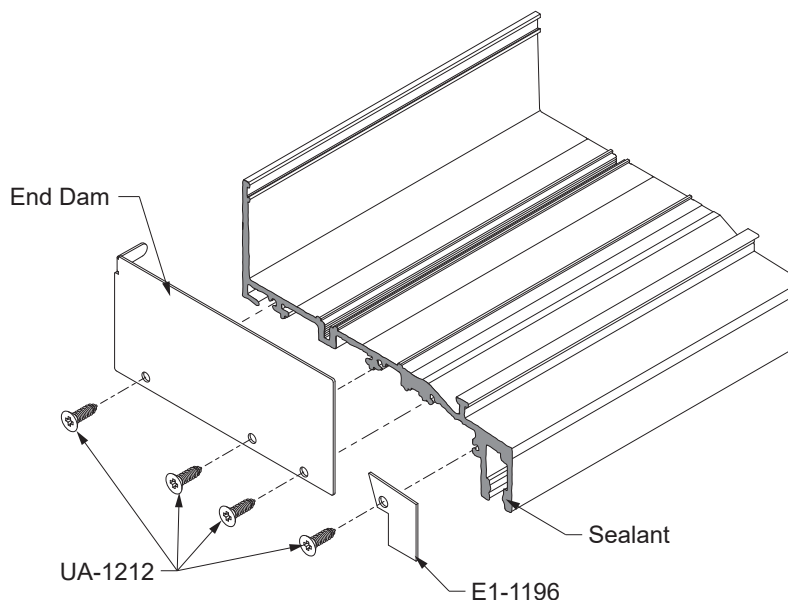

Detail 47

FRAME INSTALLATION

STEP 24 INSTALL BE9-2729 SILL FLASHING

- Prior to installing the sill flashing, slide in E1-1191 strap anchors (2 per DLO) if they are being used.
- Install the sill flashing with a minimum of 3/8" shim space underneath. Sill flashing must be installed level.
- Anchor the sill flashing to the structure a maximum of 4" from each end and then 18" to 24" on center, per P.E. calculations, or per FPA drawings.
- Apply and tool sealant to cover the heads of all anchors and screws.

STEP 25 INSTALL SILL FLASHING SPLICE SLEEVE

- Remove the nub with a chisel or pliers on both sides of the splice joint 1-1/2" as shown in **Detail 48**.
- After the sill flashing has been shimmed and anchored to the building structure, insert a small backer rod under the sill flashing as shown in **Detail 49**.
- Position the Silicone Splice Sleeve against the back wall below the groove.
- Bend the Silicone Splice Sleeve into the front on the channel as shown. Mark and cut the sleeve at this position.
- Clean Sill Flashing and Silicone Splice Sleeve with isopropyl alcohol at the splice location.
- Seal the flashing at the splice location as shown in **Detail 49**, before positioning the flashing. Set the Silicone Splice Sleeve into the sealant.
- Tool sealant tight as shown in **Detail 49**, squeezing the sheet flat with a seam roller.

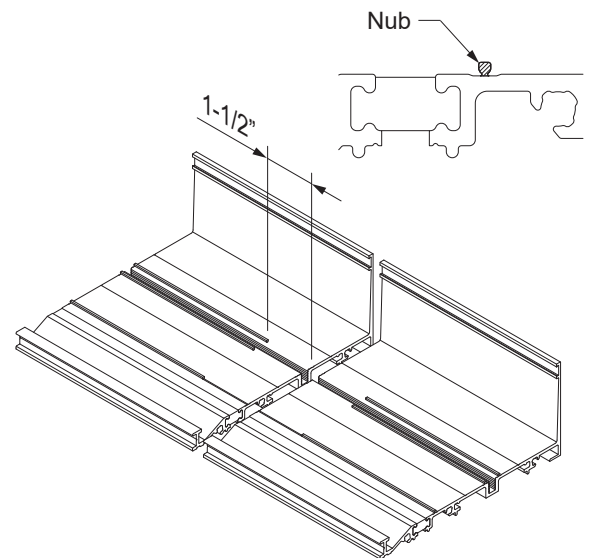

Detail 48

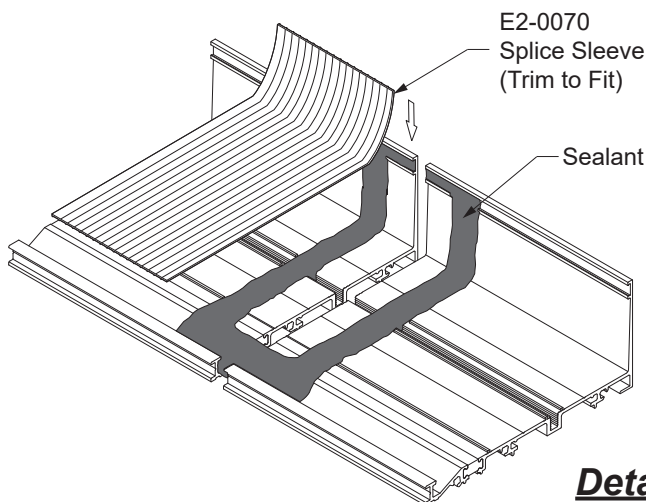

Detail 49

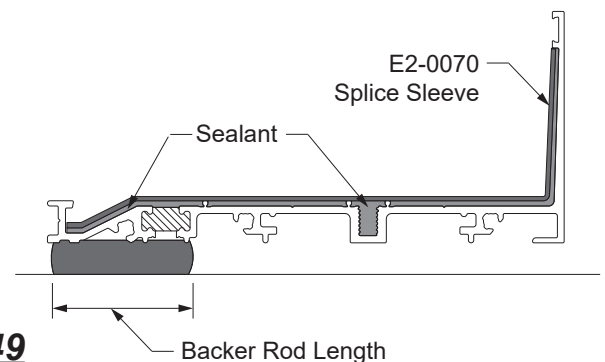

FRAME INSTALLATION

STEP 25 (Continued)
INSTALL SILL FLASHING SPLICE SLEEVE

-Thoroughly seal the small joint directly in front of the Silicone Splice Sleeve as shown in **Detail 50**.

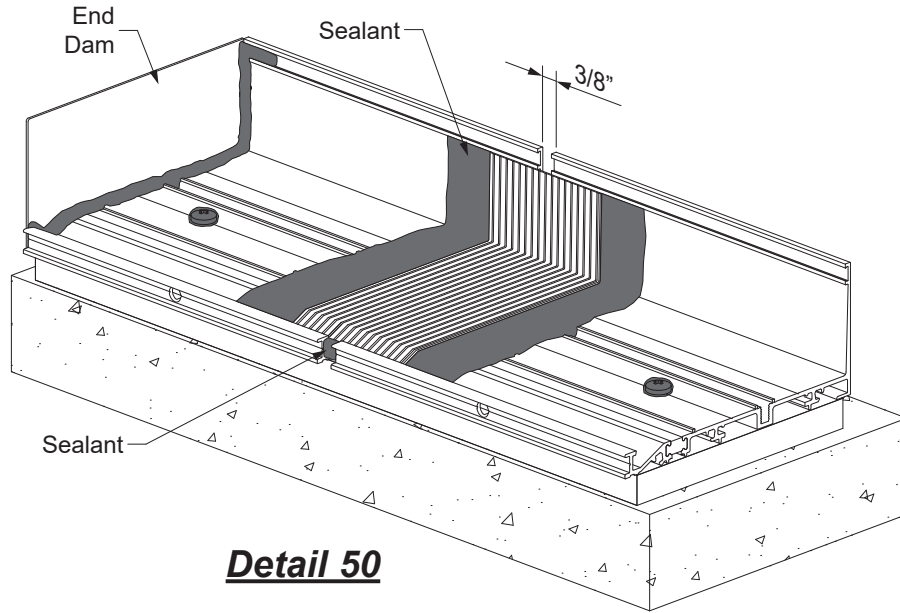

FRAME INSTALLATION

STEP 26 SLAB EDGE COVER INSTALLATION

Slab edge covers are installed from the head of the lowest elevation on upward. The head receptors are installed first, then slab edge plates, then the BE9-2735 sill flashings with the E9-8222 slab edge adaptors.

STEP 26A INSTALL HEAD RECEPTOR END DAMS & WEATHERING GASKETS

- Clean all joint surfaces using cleaner approved by sealant manufacturer.
- Apply sealant to the end of the head receptor as shown in **Detail 51**.
- Fasten the end dam to the head receptor with two UA-1212 screws, starting at the back, followed by the front.
- Tool sealant along the joint between the end dam and the end dam as shown in **Detail 51**.
- Tape down the top corners to hold the end cap in place until the sealant cures.

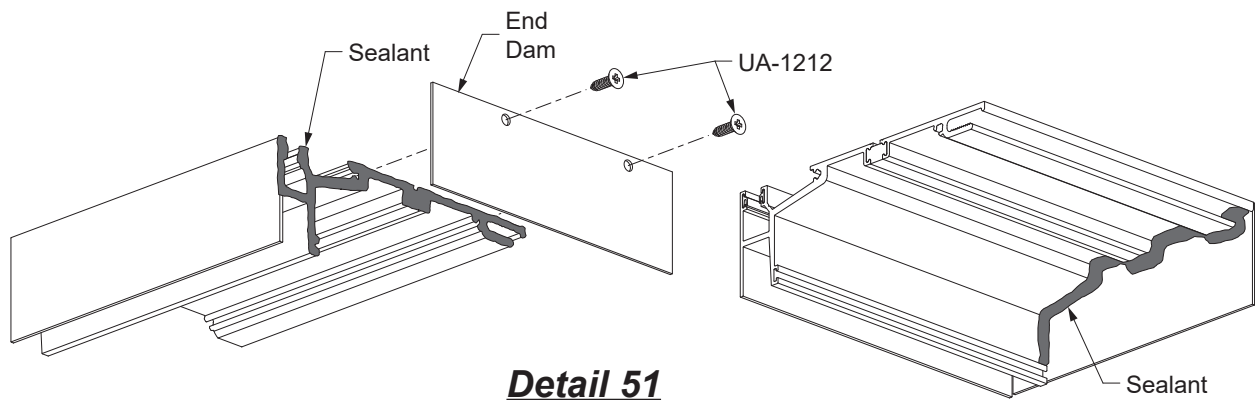

Detail 51

- Cut the E2-0051 airtight gasket to head receptor length plus 3/16" at each end for the splice joint, and insert it into its reglet for both the receptor and snap cover as shown in **Details 52 & 52A**.
- Cut the E2-0065 slab edge weathering gaskets to head receptor length. Insert the gaskets into the slab edge reglets in the orientation as shown in **Details 52A**.

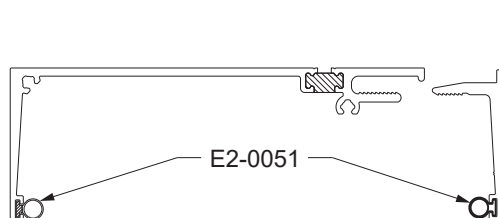

Detail 52

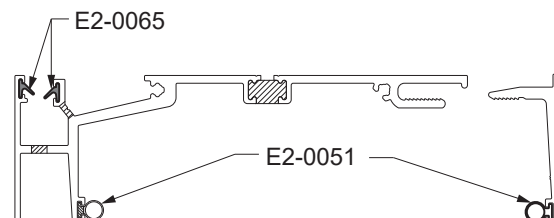

Detail 52A

FRAME INSTALLATION

STEP 26B INSTALL HEAD RECEPTOR

- Starting at the smallest opening height, install the head receptor with a minimum of 5/8" shim underneath. Head receptor must be installed level.
- Anchor the head receptor to the structure according to approved shop drawings and or P.E. calculations.
- Apply and tool sealant to the heads of all fasteners as shown on **Detail 53**.

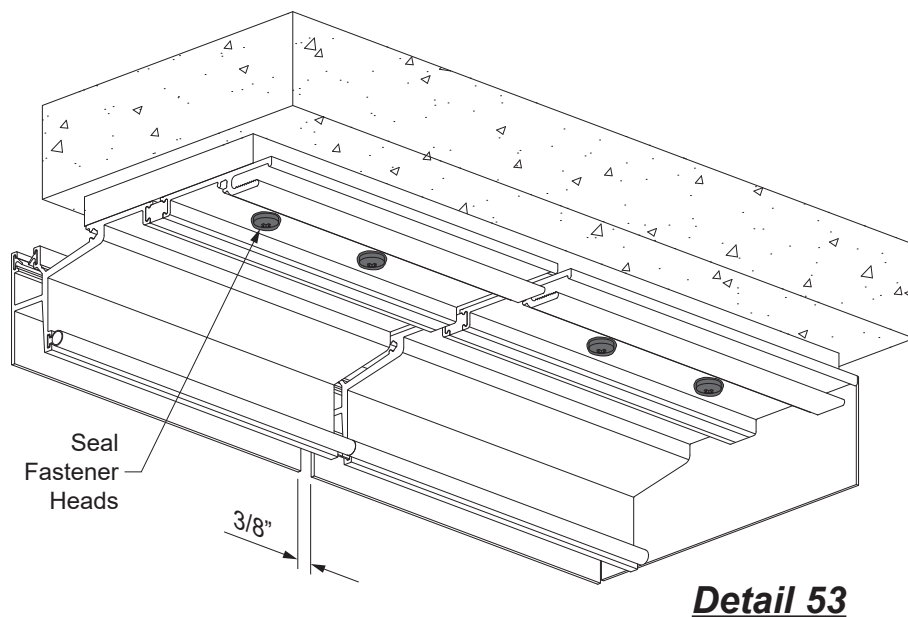

FRAME INSTALLATION

**STEP 26B (Continued)
INSTALL HEAD RECEPTOR**

-Prior to installing the Splice Sleeve, clean head receptor and Splice Sleeve with isopropyl alcohol at the splice location.

-Refer to the splice chart at the right for proper splice selection per head receptor used.

| System | Head Receptor | Splice |
|-----------|---------------|---------|
| YWW 50 TU | BE9-7635 | E2-0070 |
| YWW 50 TU | BY7-8426 | E2-0070 |
| YWW 50 TU | BE9-2819 | E1-2813 |
| YWW 60 TU | BE9-7736 | E2-0070 |
| YWW 60 TU | BE9-7229 | E1-9824 |

- Position the Splice Sleeve against the front wall inside the head receptor, set in sealant centered on the splice joint as shown in **Detail 54**. For E2-0070 sheet, trim as necessary to fit.
- Tool the sealant. For E2-0070 sheet, use a seam roller to press the sheet tight against the receptor.
- Seal the ends of the E2-0051 together at the splice.

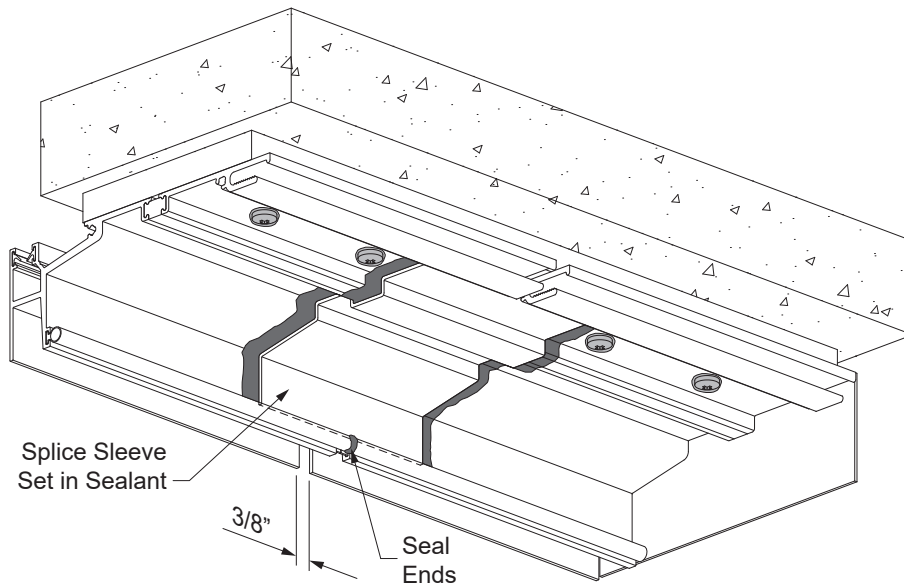

Detail 54

FRAME INSTALLATION

STEP 26B (Continued) INSTALL HEAD RECEPTOR SPLICE SLEEVE

-At the slab edge receptacle of the head receptor, position an E1-9961 splice sleeve centered on the splice joint. Set the splice sleeve in sealant, similar to the procedure previously outlined for the underside of the head receptor.

See **Detail 55**.

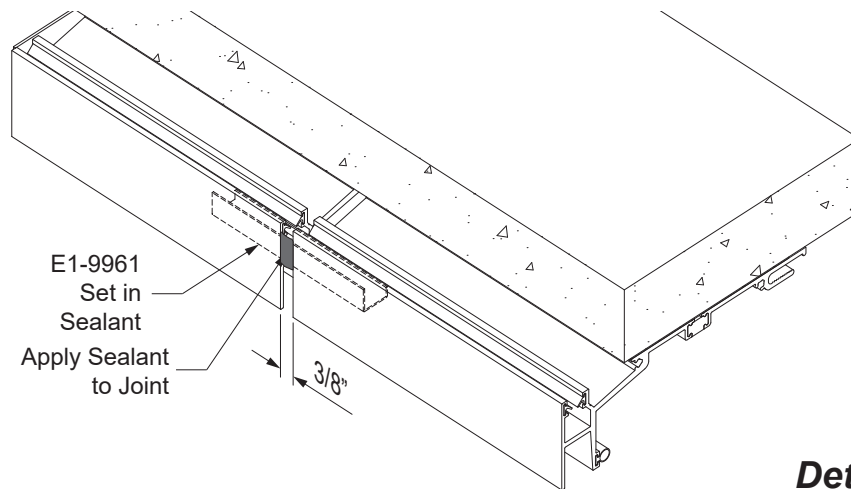

Detail 55

FRAME INSTALLATION

**STEP 26B (Continued)
INSTALL HEAD RECEPTOR GASKETS**

- Install E2-0054 setting blocks at 1/4 points of the aluminum plate.
- Install a weep baffle, E2-0099, over every weep hole location.

See **Detail 56**.

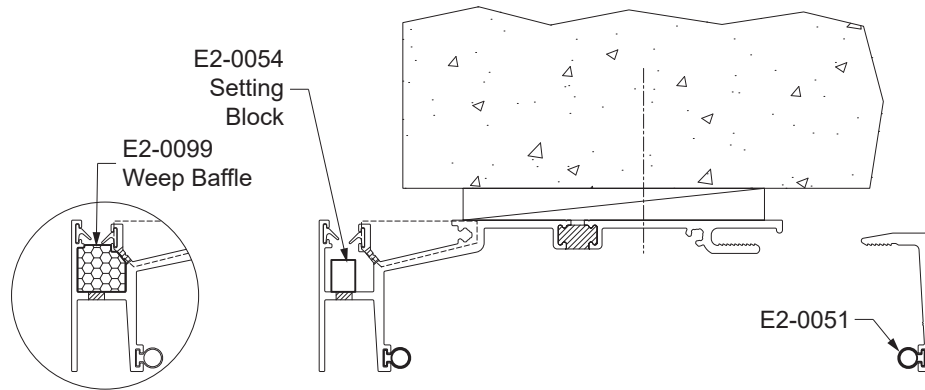

Detail 56

**STEP 26C
ASSEMBLE SLAB EDGE COVER PLATES**

- Clean the ends of the slab edge cover and attachment areas of end caps using a cleaner approved by sealant manufacturer.
- Apply and tool sealant to each end of the slab edge cover prior to attaching the end caps.
- Attach end caps to each end of the slab edge cover using (2) UA-1212 fasteners.
- Tool and wipe away any excess sealant at the joints.

See **Detail 57**.

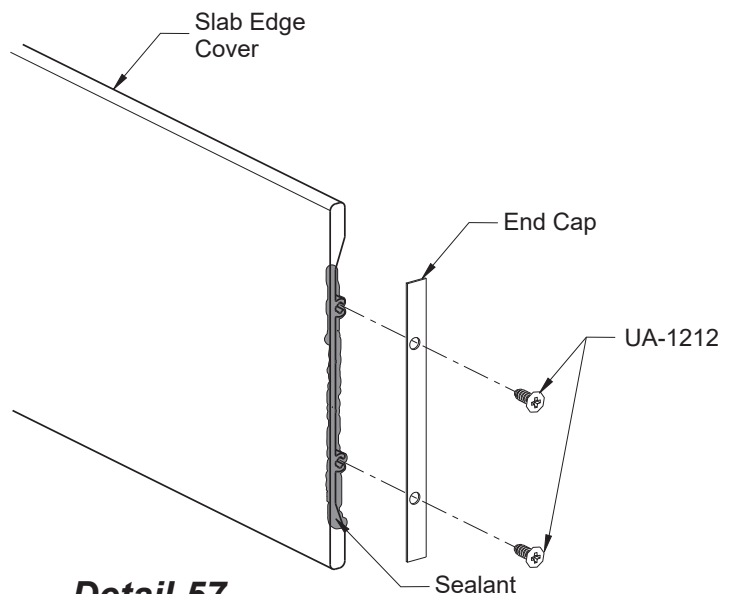

Detail 57

FRAME INSTALLATION

**STEP 26D
INSTALL SLAB EDGE COVER FASCIA**

- Prior to installing the slab edge cover, insert a continuous backer rod, and apply and tool sealant to the front underside of the slab edge, between the head receptor and the substrate.
- Slide the slab edge cover plate into the head receptor receptacle, seating it on top of the setting blocks.
- Be sure to leave a 3/8" joint between the plates for runs longer than 24'-0".

See **Detail 58**.

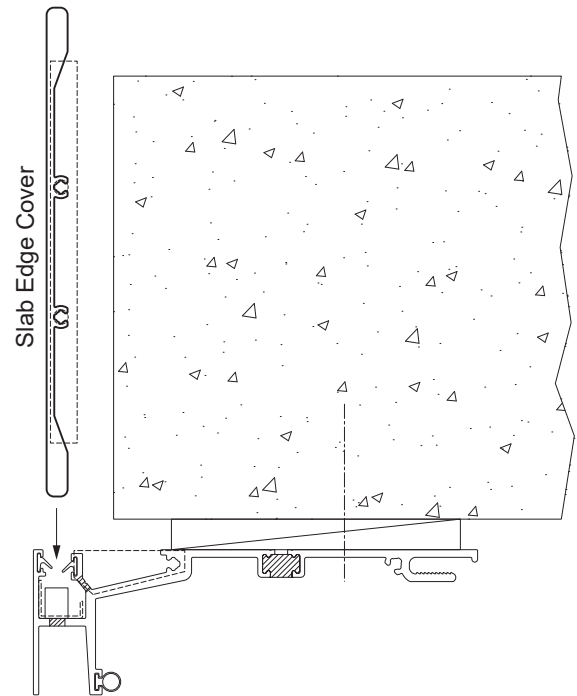

Detail 58

**STEP 26E
INSTALL SILL FLASHING SPLICE SLEEVE FOR
SLAB EDGE COVER**

- Before installing the sill flashing, install an E1-9959 splice sleeve at the underside of the sill flashing and slab edge adaptor.
- Apply bond breaker tape down the middle of the splice sleeve and sealant to one side of the splice sleeve as shown in **Detail 59**.
 - Adhere the sealed half of the splice sleeve to the underside of the sill flashing.

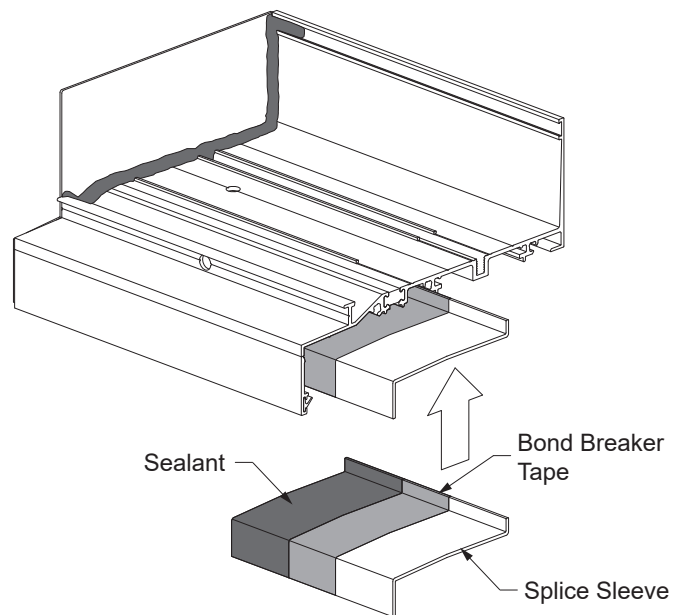

Detail 59

FRAME INSTALLATION

STEP 26E (Continued)

INSTALL SILL FLASHING SPLICE SLEEVE AT SLAB EDGE

- Install the sill flashing assembly onto the substrate, engaging the slab edge cover plates below and sealing all anchor fastener heads.
- Install the next slab edge sill flashing assembly onto the splice sleeve as shown in **Detail 60**. Be sure to leave a 3/8" joint between the sill flashing assemblies.

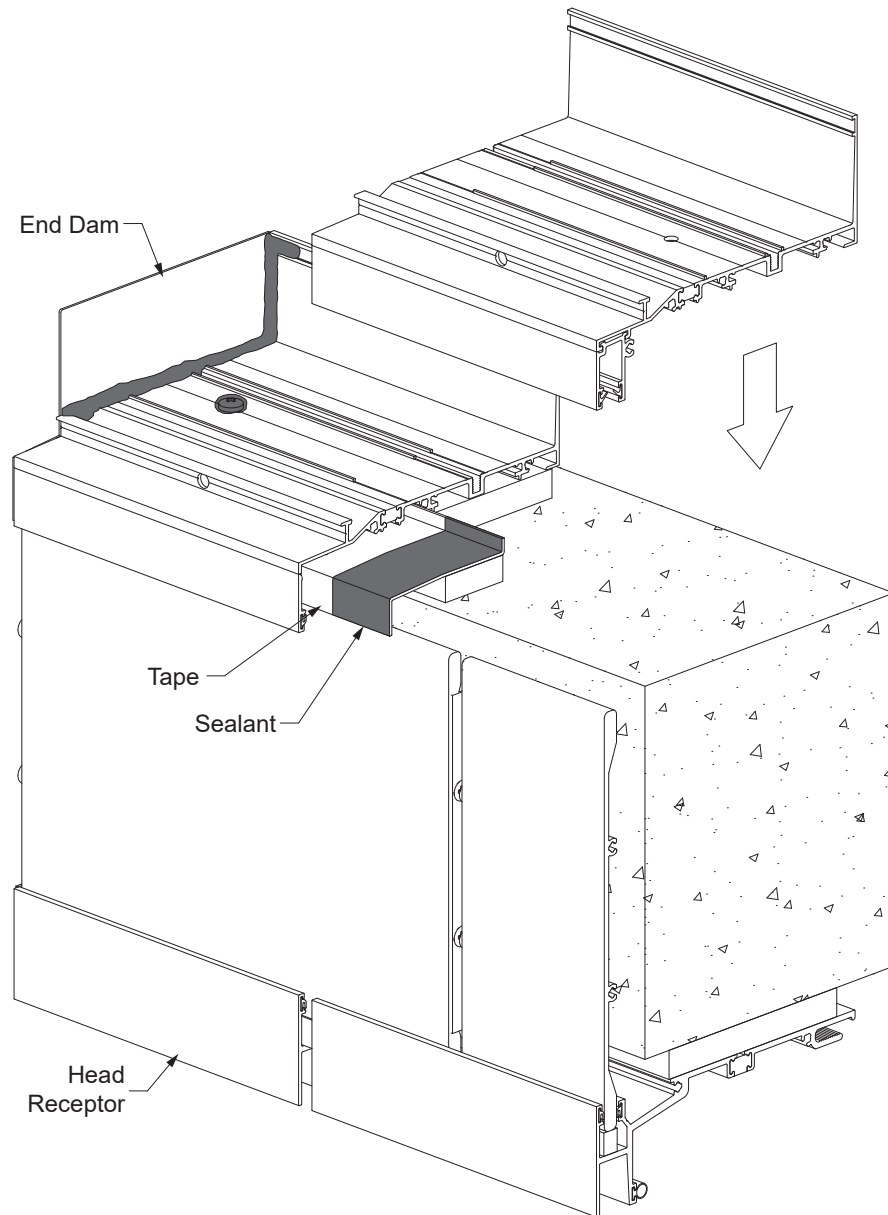

Detail 60

FRAME INSTALLATION

STEP 26E (Continued)

INSTALL SILL FLASHING SPLICE SLEEVE AT SLAB EDGE

-Installation of the E2-0070 splice sleeve is the same as previously outlined in **Step 25**, except to apply sealant to the joint at the slab edge cover plate, adaptor, and head receptor as shown in **Detail 61**.

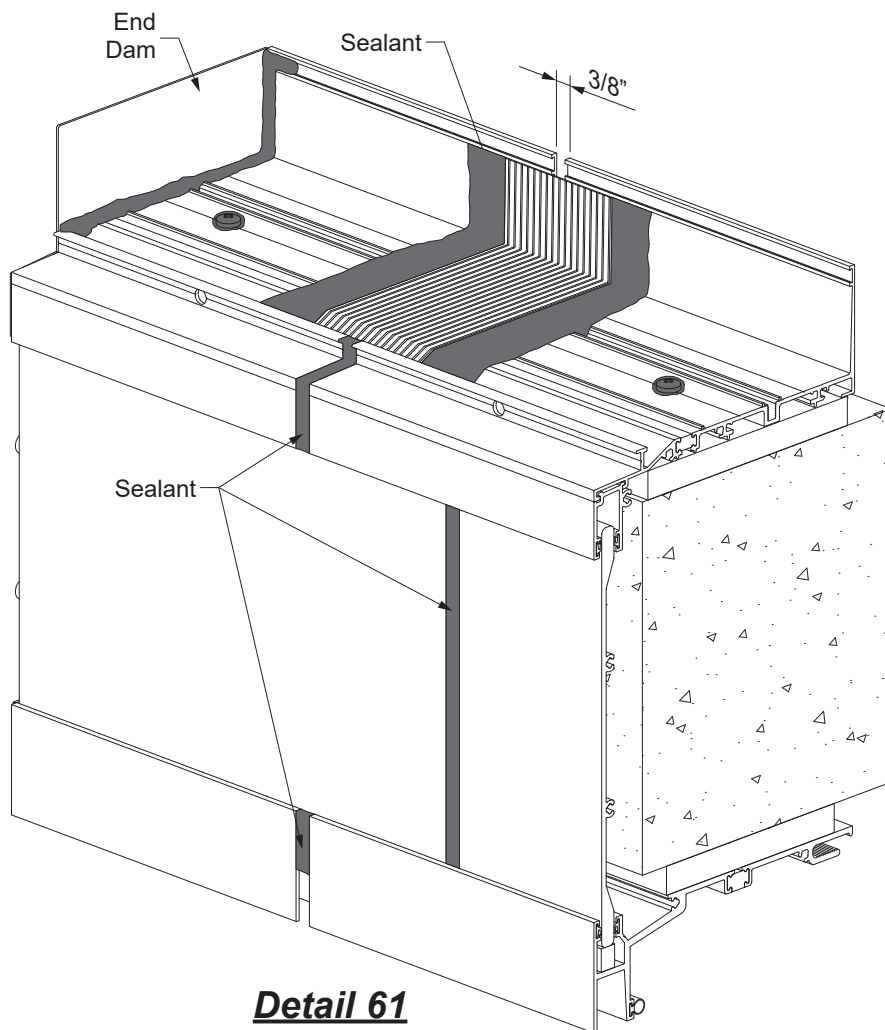

FRAME INSTALLATION

**STEP 27
INSTALL BE9-2729 SILL FLASHING AT CORNERS**

- Cut two 12" long pieces of sill flashing and miter(45° for 90° corners).
- Align the two pieces at the corner condition with the mitered ends pushed together tight and anchor the sill flashing as indicated on the approved shop drawings and or P.E. calculations.
- Apply and tool sealant to the mitered joint and anchor heads.

See **Detail 62**.

- Continue installing the rest of the sill flashing providing a 3/8" expansion joint at splices as shown in **Step 23 & 24 on Page 42 to 44**.

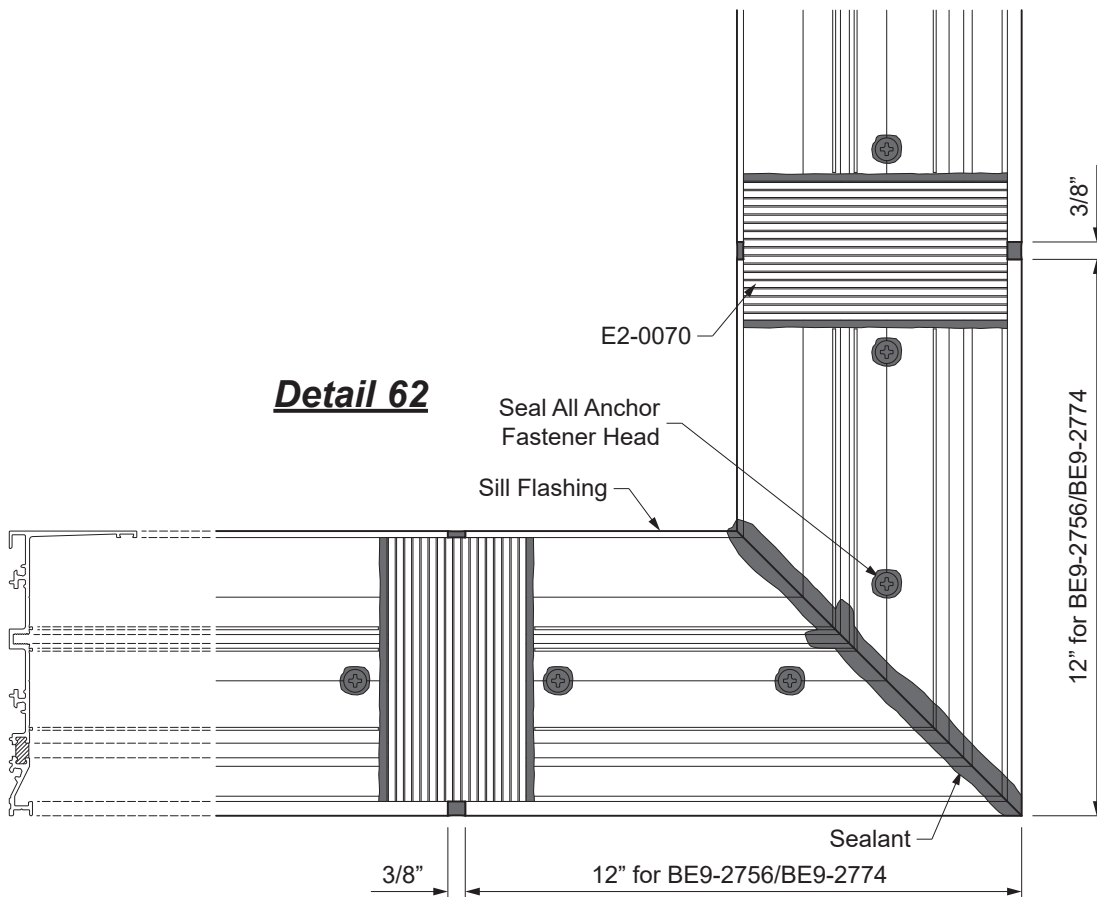

FRAME INSTALLATION

STEP 27A
INSTALL BE9-2735 SILL FLASHING AT CORNERS *

- Cut two 13-3/16" long pieces of BE9-2735 sill flashing and E9-8222 slab edge cover adaptor, and miter (45° for 90° corners). The head receptor that is to be installed below will also receive the same miter cut fabrication.
- Install the head receptor using similar procedure as previously described for the sill flashing.
- Miter cut the slab edge cover plates 45° for 90° corners, such that upon installation, they leave a 1/2" gap at the corner.
- Fasten end caps onto the edge of the slab edge cover plates.
- Install the slab edge plates onto the setting blocks of the head receptor below.
- Align the two pieces of the BE9-2735 sill flashing at the corner condition with the mitered ends pushed together tight and anchor the sill flashing as indicated on the approved shop drawings and or P.E. calculations.
- Apply and tool sealant to the mitered joint and anchor heads.

See **Detail 63**.

- Continue installing the rest of the sill flashing providing a 3/8" expansion joint at splices as shown in **Step 26 Pages 46 to 53**.

* **Note:** Similar technique required for head receptor.

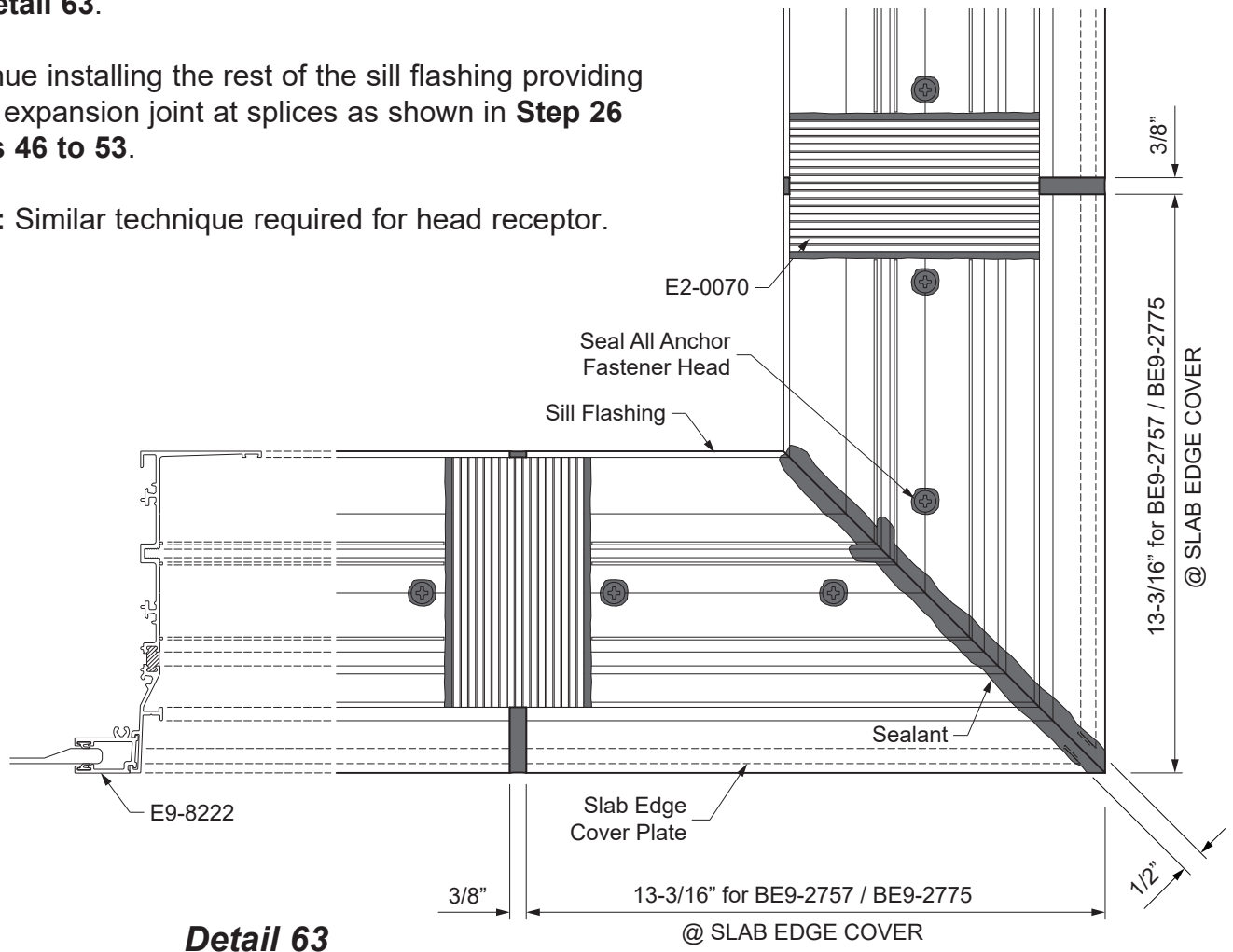

FRAME INSTALLATION**STEP 28
SILL PREPARATION**

At every splice condition, apply bond breaker tape to the back of the sill member before the joint is sealed between the sill and sill flashing.

See **Detail 64**.

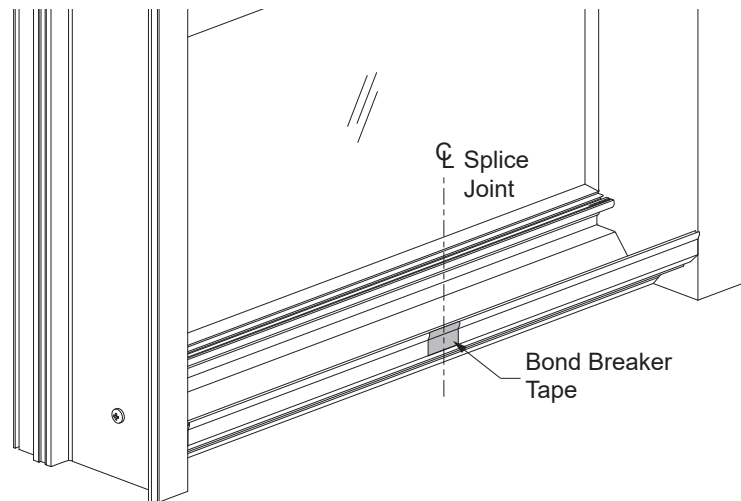

Detail 64

FRAME INSTALLATION

STEP 29
INSTALL FRAMES

-The female mullion half of the second unit engages into the male mullion half of the previously installed unit, from the side.

-For frames that utilize the E1-1190 channel shaped head anchor, secure the anchor to the head using masking tape as shown in **Detail 65** prior to installation into the frame opening.

-Set the frame into place. See **Detail 66** for shim space at head.

-Taking care to ensure the framing unit is plumb, level, square, and true, anchor the framing unit to the substrate, first at the head using fasteners as specified by engineering calculations.

See **Detail 66**.

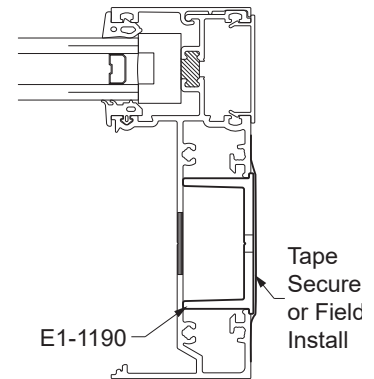

Detail 65

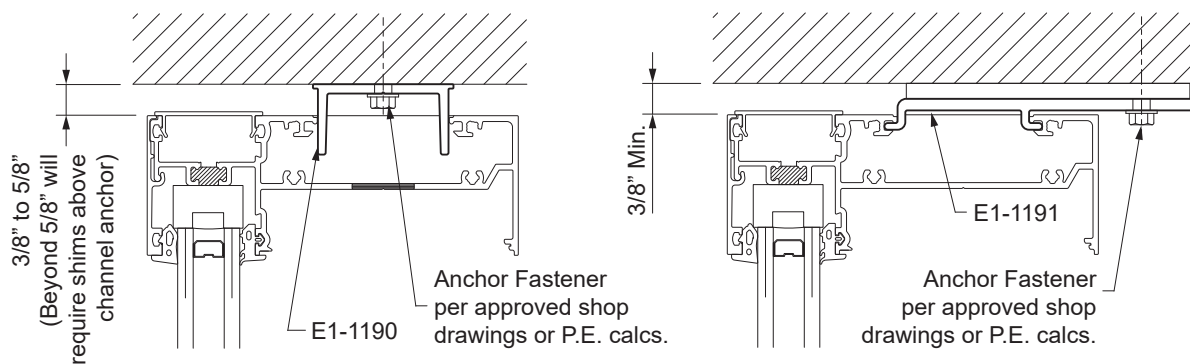

Detail 66

FRAME INSTALLATION

**STEP 29 (Continued)
INSTALL FRAMES**

-For end reactions greater than 500 lbs. per mullion, fasten the sill to the sill flashing using two (2) PM-2508-SS screws, one at 3" from each end of the sill.

See **Detail 67**.

-Then anchor the jamb strap anchors to the substrate, if applicable.

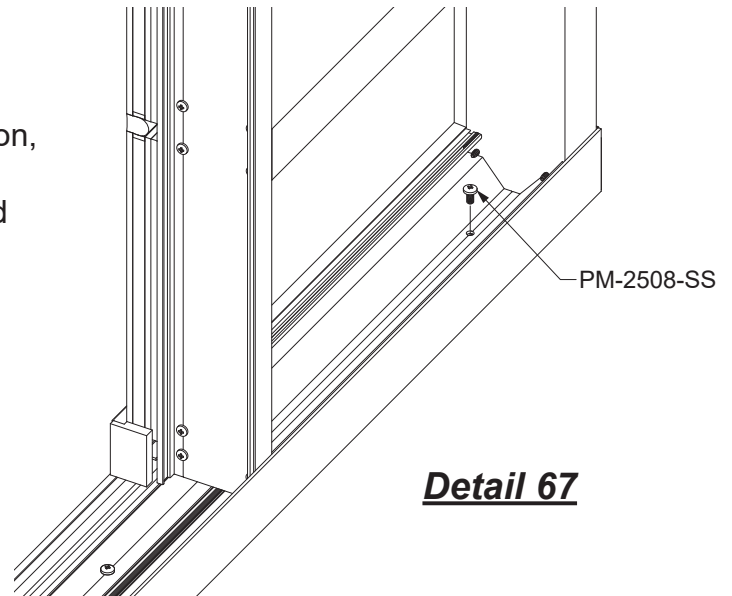

**INSTALL FRAMES WITH
HEAD RECEPTOR**

-Set the frame into place, taking care to ensure the unit is plumb, level, square, and true.
-Snap on the receptor snap cover with the E2-0051 airtight gasket onto the head receptor.

See **Detail 68**.

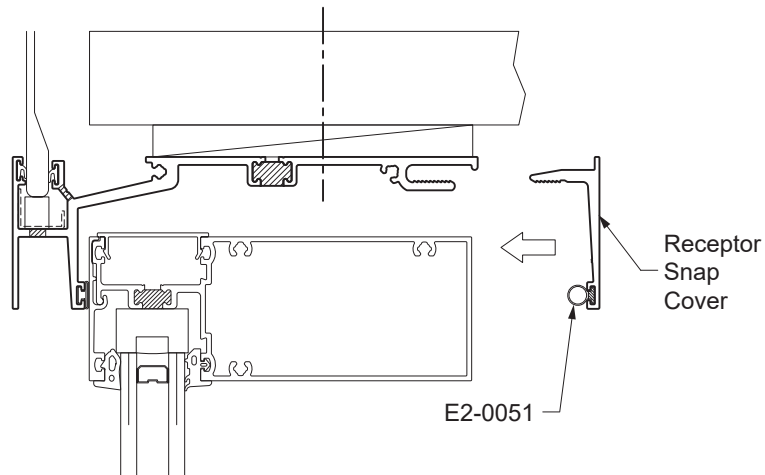

Detail 68

FRAME INSTALLATION

STEP 30 (Continued)
INSTALL FRAMES

Note: If sill has not fully engaged into the sill flashing, tap down with a block of wood to ensure proper engagement prior to sealing.

- Apply sealant to the back of the sill member (the length of the sill) of the installed unit at the sill flashing as shown in **Detail 69**.
- Just prior to installing the next unit, apply sealant to the interior reglet of the female mullion where it will interface with the male mullion of the installed unit (from bottom of mullion and 6" up.) Also, apply 6" of sealant to the sill flashing centered on the mullion centerline as shown in **Detail 70**.

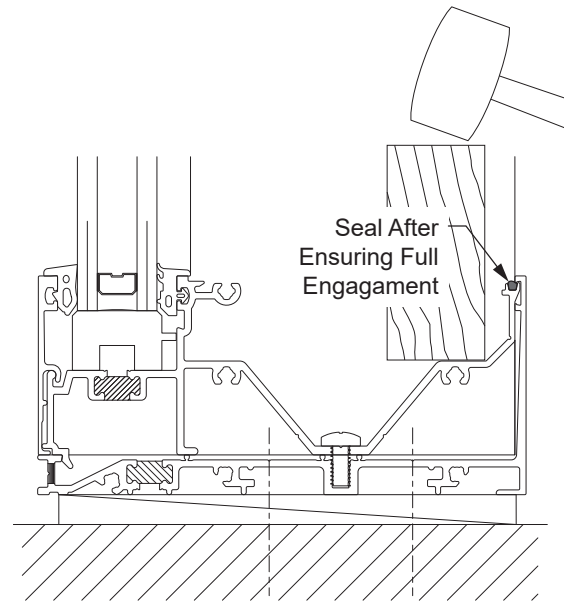

Detail 69

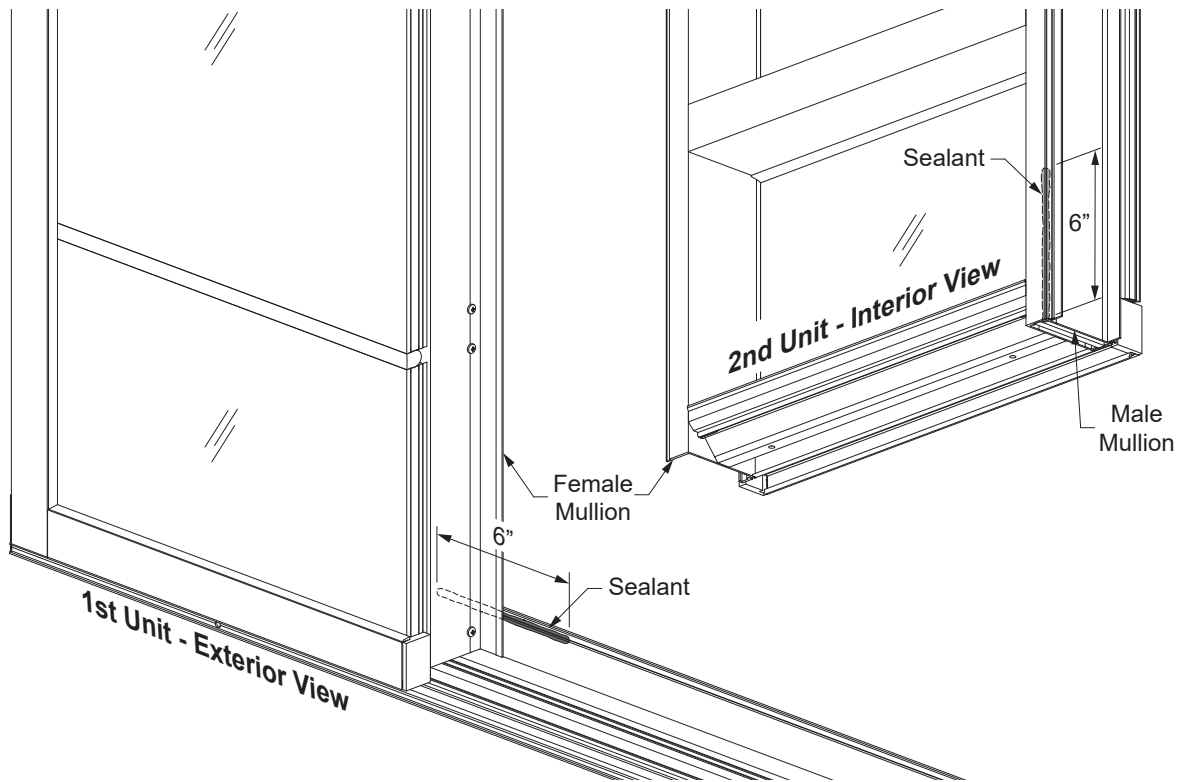

Detail 70

FRAME INSTALLATION**STEP 30 (Continued)
INSTALL FRAMES**

-Install the next framing unit, taking care to ensure that the unit is plumb, level, square, and true, and that the female mullion fully interfaces with the male mullion from the previous unit.

See **Detail 71 & 71A**.

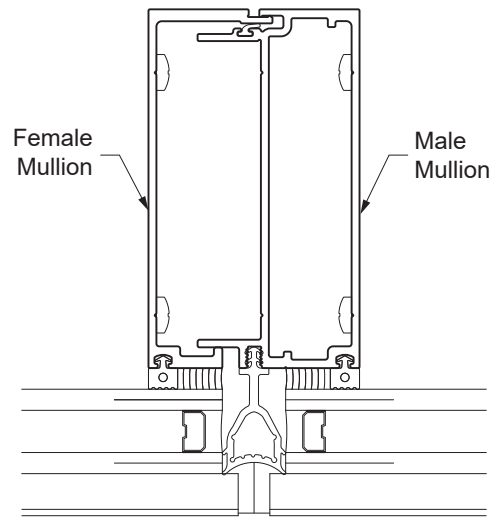

Detail 71

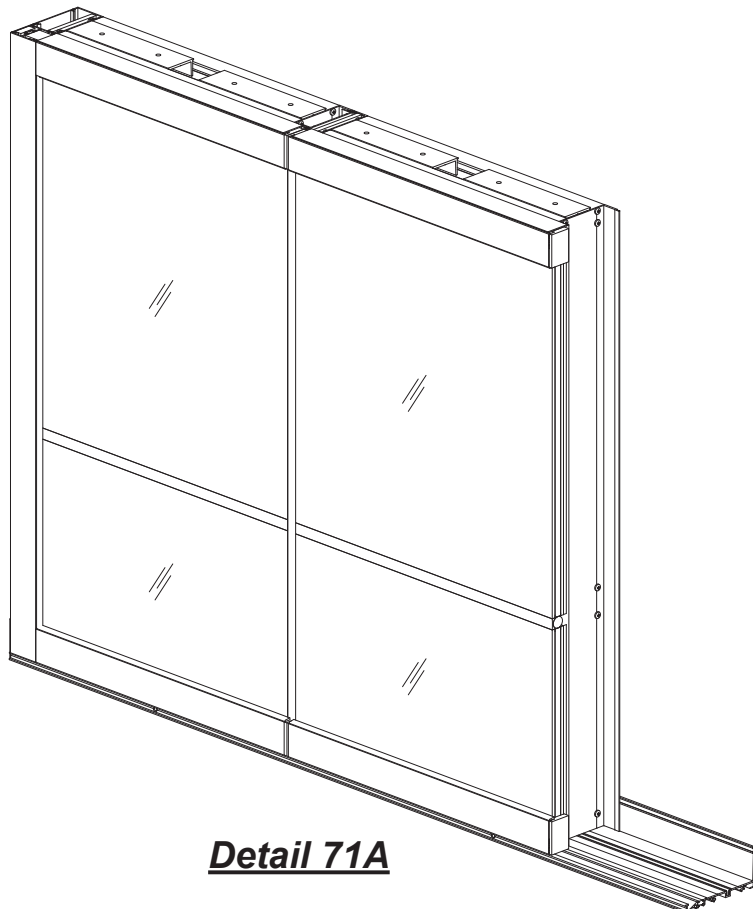

Detail 71A

FRAME INSTALLATION

STEP 30 (Continued)
INSTALL FRAMES

-Fill the void between the two units at the back of the sill flashing with sealant.

See **Detail 72**.

-Repeat **Step 30** until all units are installed.

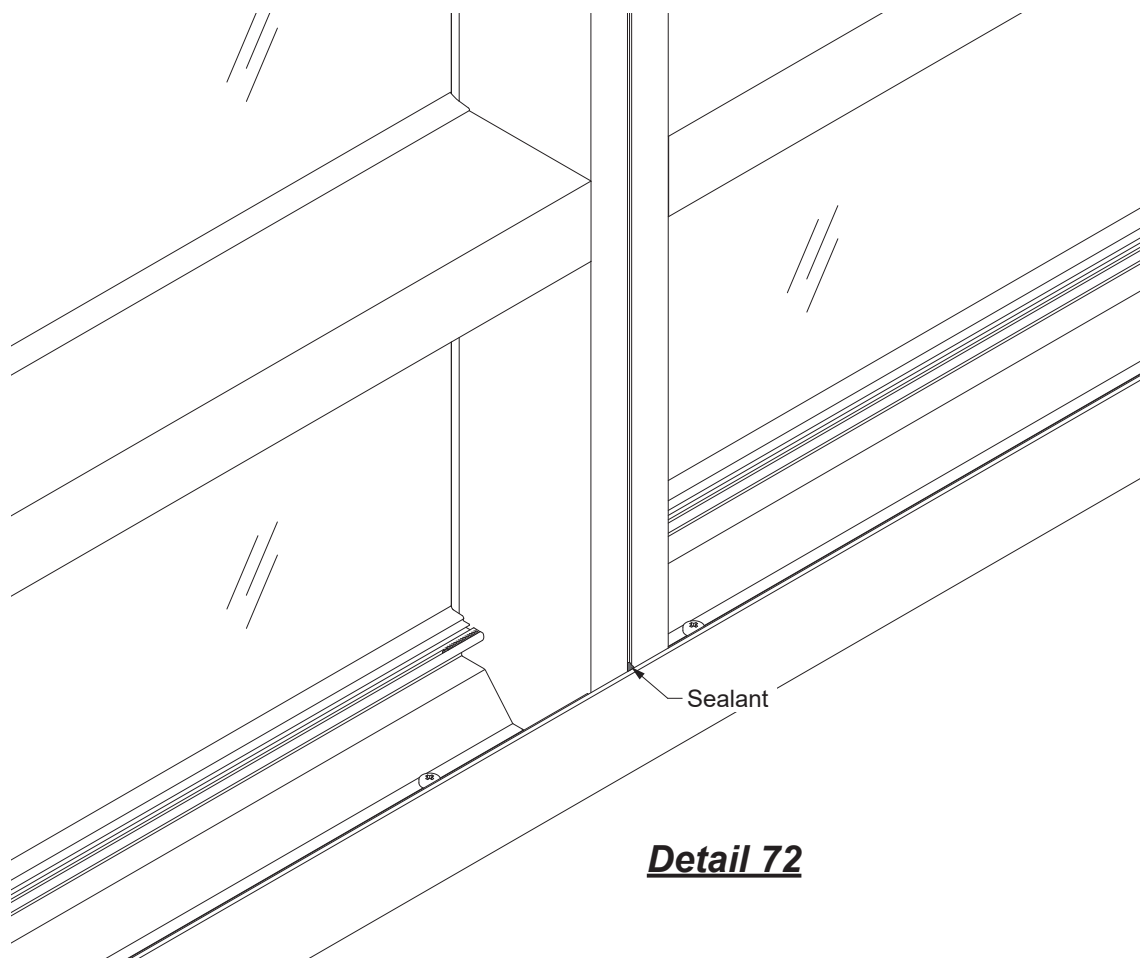

Detail 72

FRAME INSTALLATION

**STEP 31
APPLY PERIMETER SEALANT**

- Once all the units are installed, apply perimeter sealant required on interior and exterior of the window wall system.
- Install backer rod around the perimeter of the frame.
- Apply perimeter sealant to the joint between the frame and the structure.
- Avoid getting sealant into the sill flashing weep holes.

See **Detail 73**.

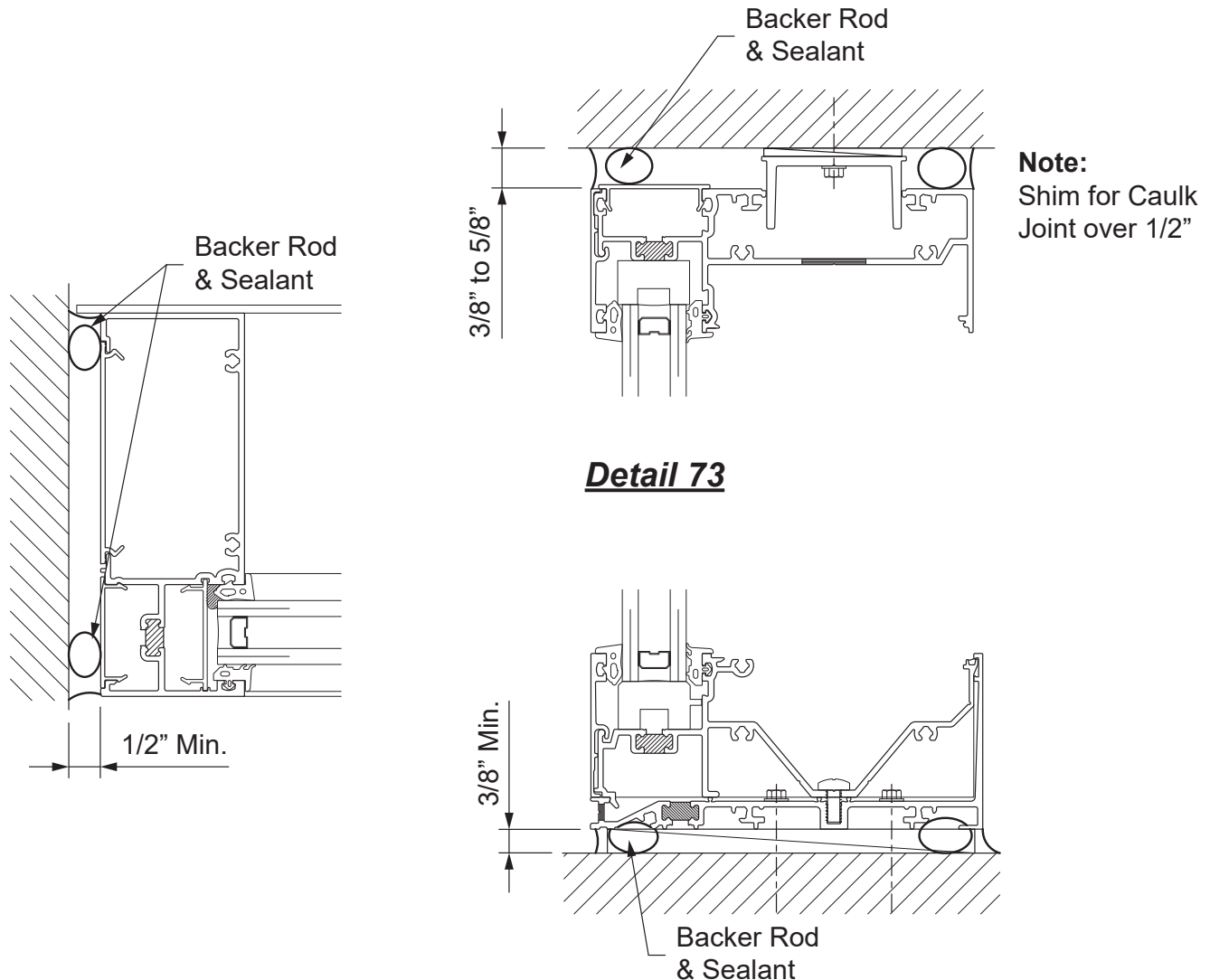

FRAME INSTALLATION

STEP 31A

APPLY PERIMETER SEALANT AT SLAB EDGE COVERS

- For slab edge covers at the head and sill, install a backer rod and apply sealant to the back of the sill flashing and head receptor.
- Tool sealant prior to skinning over.
- Install a backer rod and seal the jamb edge of the slab edge covers.

See **Detail 74**.

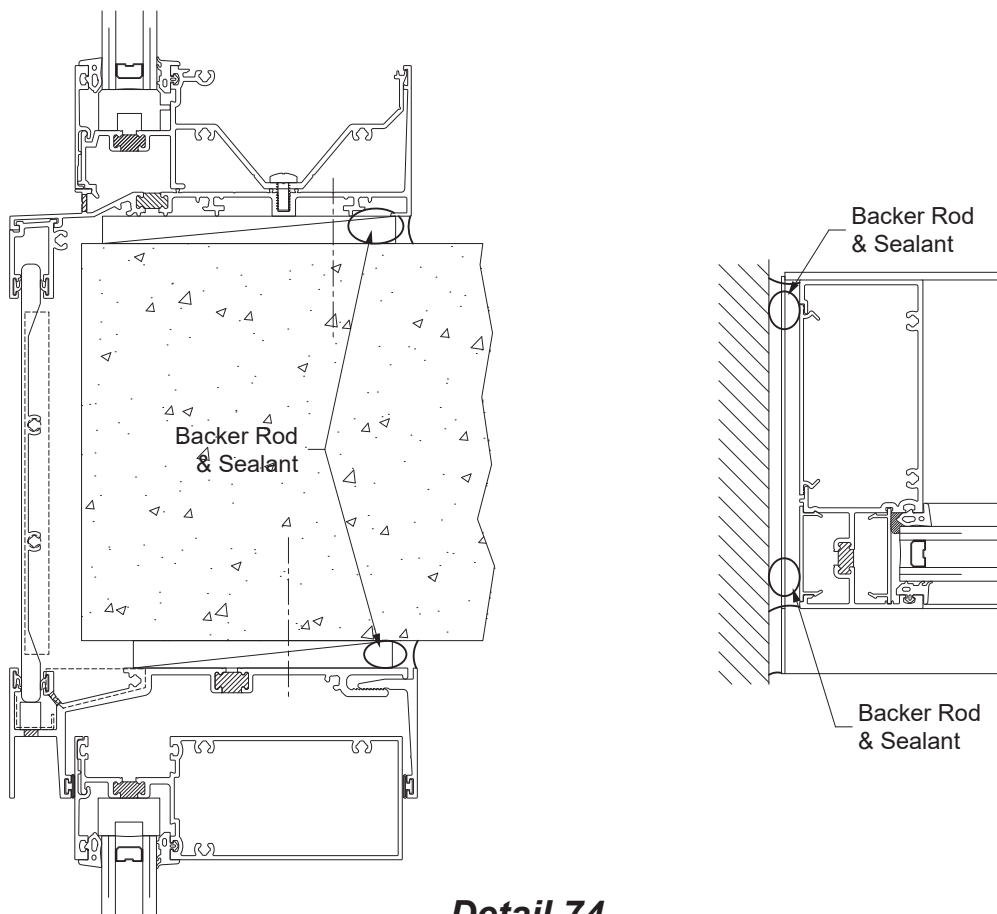

Detail 74

FRAME INSTALLATION

**STEP 31B
APPLY SEALANT AT CORNER MULLIONS**

-Apply backer rod and sealant the at the interior of the corner mullion, the full height of the mullion.
Do not seal the exterior side.

See **Detail 75**.

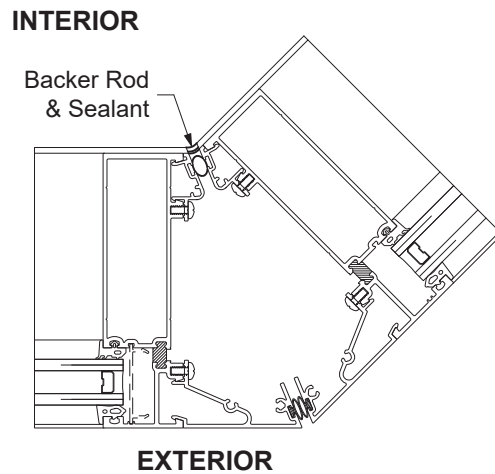
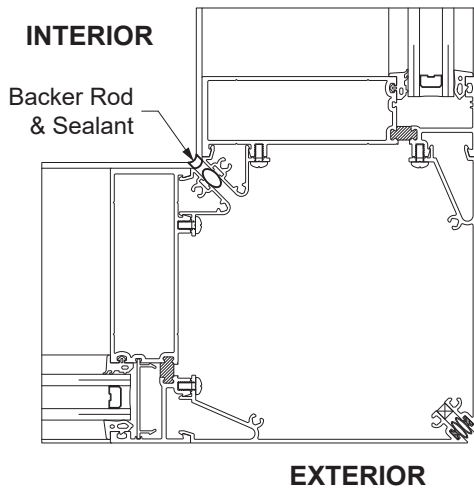

Detail 75

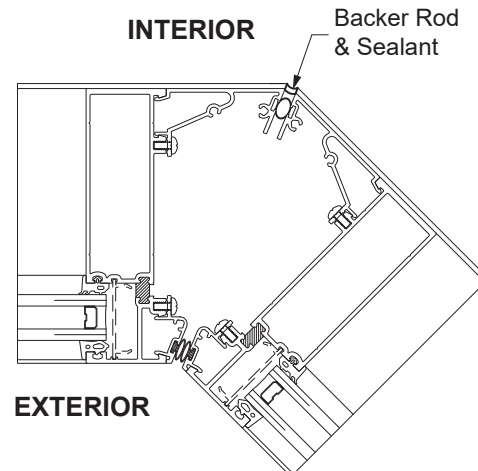
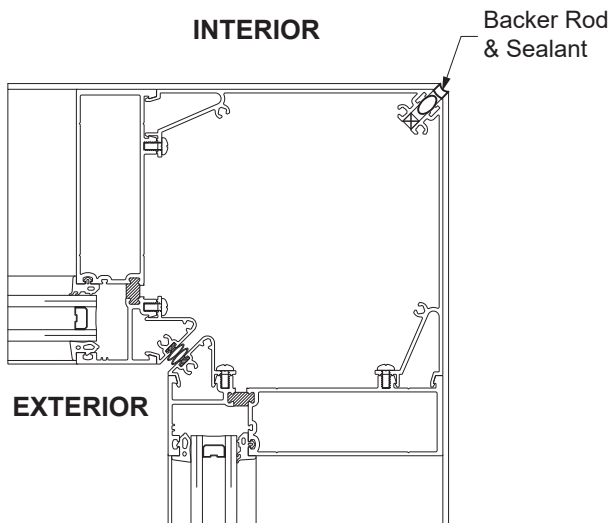

FRAME INSTALLATION

STEP 32

INSTALL INTERIOR COVERS

-Snap on the interior covers at the head, horizontals, and sills.

YWW 50 TU

E9-2780 sill and head

YWW 60 TU

E9-2762 @ sill and head

See **Details 76**.

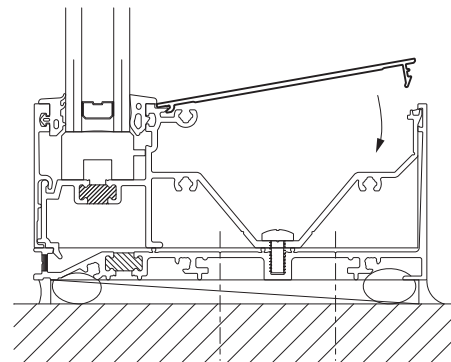
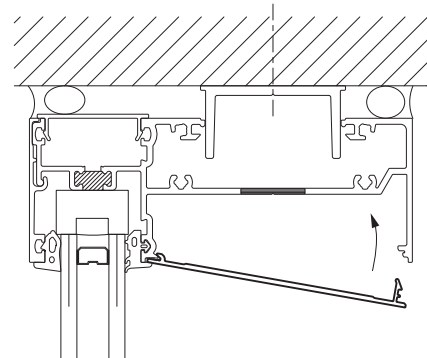

Detail 76

 **YKK AP America Inc.**

270 Riverside Parkway

Suite 100

Austell, Georgia 30168

www.ykkap.com