

YWW 50 TU / YWW 60 TU Window Wall Installation Manual Preglazed Captured

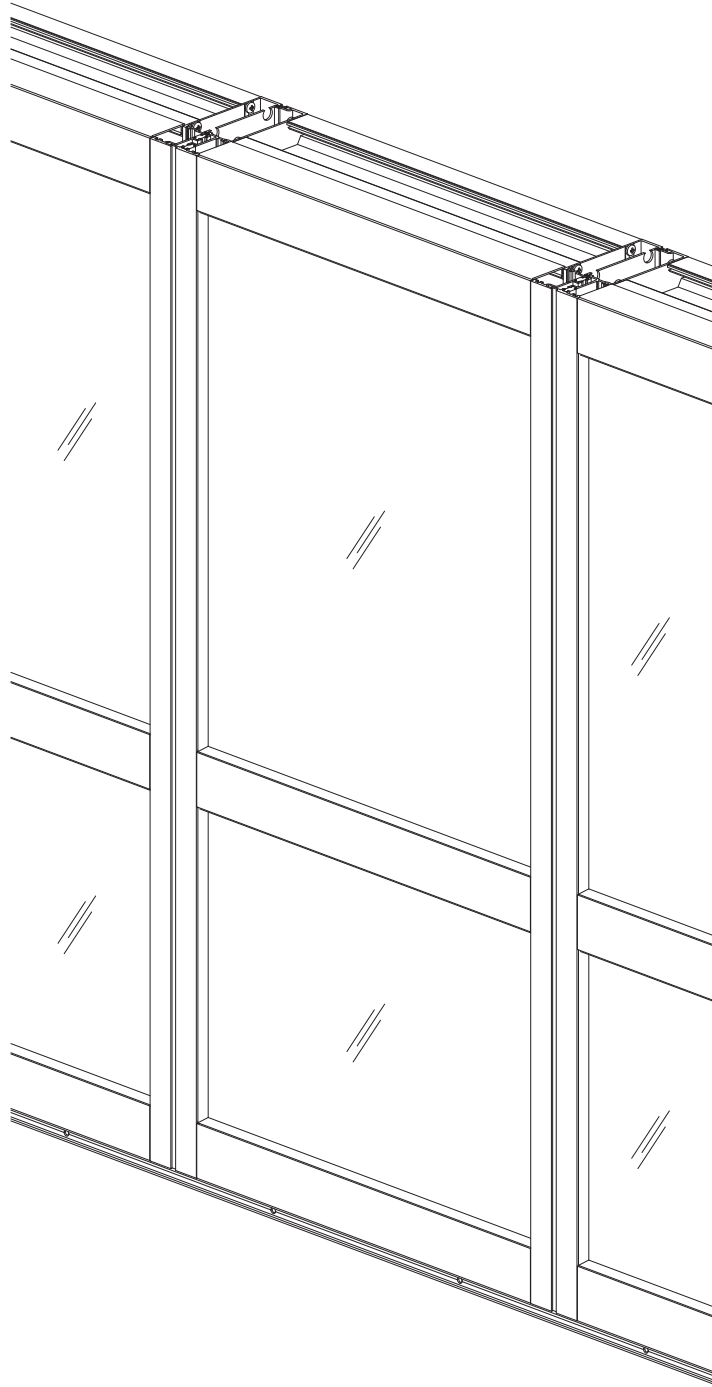

TABLE OF CONTENTS

Installation Notes.....	Page ii
PARTS DESCRIPTION	
Framing Members.....	Pages 1 to 4
Accessories.....	Pages 5 & 6
FRAME FABRICATION	
Determine Frame Size.....	Pages 7 & 8
Fabricate Vertical Members.....	Pages 9 & 10
Fabricate Horizontals.....	Pages 11 to 12
Fabricate Glass Stops.....	Page 13
Fabricate Sill Flashing.....	Page 14
Fabricate Slab Edge Plate Adaptor.....	Page 15
Fabricate Corner Covers.....	Page 15
Fabricate Head Receptors.....	Page 16
Fabricate 1/4" Glazing Adaptors (Where Required).....	Page 16
FRAME ASSEMBLY	
Assemble Frame.....	Pages 17 to 21
Secure Unit Frame.....	Page 22
Install Steel Reinforcing (Optional).....	Page 23
Install Perimeter Fillers.....	Page 24
Install Foam Plugs at Head.....	Page 25
Install Weather Seal.....	Page 26
Install Water Deflector.....	Page 27
Install PVC Filler at Jamb Glazing Pocket.....	Page 28
Install Dart Gaskets.....	Pages 29 & 30
GLAZING	
Install Setting / Side Blocks.....	Page 32
Install Glass.....	Pages 33 & 34
Install Anti-Walk Blocks.....	Page 35
Install Glass Stops (Outside Glazing).....	Page 36
Install Glass Stops (Inside Glazing).....	Page 37
Seal Glass to PVC Fillers at Jambs.....	Page 38
Install Wedge Gaskets.....	Pages 39 to 40
FRAME INSTALLATION	
Install Sill Flashing End Dams.....	Page 40 & 41
Install Sill Flashing.....	Page 42
Install Flashing Splice Sleeve.....	Pages 42 & 43
Install Slab Edge Covers.....	Pages 44 to 51
Install Sill Flashing at Corners.....	Pages 52 & 53
Sill Preparation.....	Pages 54
Install Frames.....	Pages 55 to 58
Apply Perimeter Sealant.....	Pages 59 to 61
Install Interior Covers.....	Page 62
DOOR FRAME INSTALLATION	
Install Door Frame.....	Pages 63 & 64
Glaze Door Transom.....	Page 65















Installation Notes

1. Do not drop, roll or drag boxes of aluminum framing. Move and stack boxes with proper support to prevent distortion. If fork lifts are used, be especially careful about striking the boxes when lifting or moving.
2. Store in a dry, out of the way area. If rain exposure, condensation or any water contact is likely, then all packaging material should be removed. Wet packaging materials will discolor and may stain aluminum finishes and paints.
3. All materials should be checked for quality and quantity upon receipt, YKK AP must be notified immediately of any discrepancies in shipment. Check to make sure that you have the required shims, sealants, supplies and tools necessary for the installation.
4. Carefully check the openings and surrounding conditions that will receive your material. Remember, if the construction is not per the construction documents, it is your responsibility to notify the general contractor in writing. Any discrepancies must be brought to the general contractor's attention before you proceed with the installation.
5. Gather your shop drawings, materials, packing list, and this installation manual. Carefully review parts location, the sequence it goes therein, when you glaze it and how you seal it. Installation instructions are of a general nature and may not cover every condition you will encounter. The shop drawings and/or installation manuals were prepared specifically for the product.
6. Any material substitutions must be of equal or greater quality.
7. Make certain that material samples have been sent for compatibility testing for all manufacturer's sealants involved. Make certain sealants have been installed in strict accordance with the manufacturer's recommendations and specifications.
8. Remember to isolate, in an approved manner, all aluminum from uncured masonry or other incompatible materials.
9. System-to-structure fasteners are not supplied by YKK AP. Fasteners called out on shop drawings are to indicate minimum sizes for design loading.
10. If any questions arise concerning YKK AP products or their installation, contact YKK AP for clarification before proceeding.
11. YKK AP storefront and/or curtain wall framing is typically completed before drywall, flooring and other products which may still be in process. Take the extra time to wrap and protect the work produced.
12. Cutting tolerances are plus zero, minus one thirty second unless otherwise noted.
13. Check our website, www.ykkap.com, for the latest installation manual update prior to commencing work.

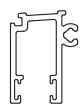
YWW 50 TU FRAMING MEMBERS

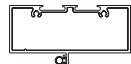
	Female Mullion	BE9-2764		Sill Flashing	BE9-2774
	Male Mullion	BE9-2765		Sill Flashing for Slab Edge	BE9-2775
	Jamb 2-1/4" x 5"	BE9-2766		Head Receptor	BE9-7635
	Corner Mullion Half 2-1/4" x 5"	BE9-2779		Optional Head Receptor	BY7-8426
	Head (IG) 2-1/2" x 5"	BE9-2785		Head Receptor w/ Plate Adaptor	BE9-2819
	Optional Head (IG)	BE9-2776		Receptor Snap Cover Used with BE9-7635	E9-8720
	Head (OG) 2-1/2" x 5"	BE9-2771		HD Receptor Snap Cover Used with BE9-2819 & BY7-8426	E9-8157
	Horizontal (IG)	BE9-2786		90° Corner Cover (Large)	E9-2783
	Optional Horizontal (IG)	BE9-2777		90° Corner Cover (Small)	E9-2741
	Horizontal (OG)	BE9-2772		135° Corner Cover (Large)	E9-2784
	Sill (OG)	BE9-2773		135° Corner Cover (Small)	E9-2743
	Sill (IG)	BE9-2778		Glass Stop	E9-7852











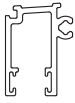

YWW 50 TU FRAMING MEMBERS (Continued)

	Interior Cover	E9-2782		7-7/8" Slab Edge Cover For Use with 7-7/8" Slab	E9-8231
	Flush Filler	E9-2780		8" Slab Edge Cover For Use with 7" Slab	E9-8589
	Glass Stop With Trim Cover	E9-2781		9" Slab Edge Cover For Use with 8" Slab	E9-8428
	Exterior Glass Stop	E9-1715		Anchor	E9-2732
	Aluminum Plate Adaptor For BE9-2735	E9-8222		Door Jamb Adaptor Subframe	E9-2344
	6-1/8" Slab Edge Cover For Use with 5-1/8" Slab	E9-8059		4-1/2" x 1-3/4" Door Head	AS-0402
	6-5/8" Slab Edge Cover For Use with 5-5/8" Slab	E9-7723		Flat Filler	BY7-9241
	7-3/8" Slab Edge Cover For Use with 6-3/8" Slab	E9-8223			





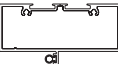

YWW 60 TU FRAMING MEMBERS

	Female Mullion	BE9-2746		Sill Flashing	BE9-2756
	Male Mullion	BE9-2747		Sill Flashing for Slab Edge	BE9-2757
	Jamb 2-1/4" x 5"	BE9-2748		Head Receptor	BE9-7736
	Corner Mullion Half 2-1/4" x 6"	BE9-2761		Head Receptor w/ Plate Adaptor	BE9-7299
	Head (IG)	BE9-2787		HD Receptor Snap Cover Used with BE9-7736 & BE9-7299	E9-8157
	Optional Head (IG)	BE9-2758		90° Corner Cover (Large)	E9-2783
	Head (OG) 2-1/2" x 6"	BE9-2753		90° Corner Cover (Small)	E9-2741
	Horizontal (IG)	BE9-2788		135° Corner Cover (Large)	E9-2784
	Optional Horizontal (IG)	BE9-2759		135° Corner Cover (Small)	E9-2743
	Horizontal (OG)	BE9-2754		Glass Stop	E9-7852
	Sill (OG)	BE9-2755		Interior Cover	E9-7853
	Sill (IG)	BE9-2760		Glass Stop With Trim Cover	E9-2763

YWW 60 TU FRAMING MEMBERS (Continued)

	Flush Filler	E9-2762		8" Slab Edge Cover For Use with 7" Slab	E9-8589
	Exterior Glass Stop	E9-1715		9" Slab Edge Cover For Use with 8" Slab	E9-8428
	Aluminum Plate Adaptor For BE9-2735	E9-8222		Head Anchor	E9-2732
	6-1/8" Slab Edge Cover For Use with 5-1/8" Slab	E9-8059		Strap Anchor	E9-2733
	6-5/8" Slab Edge Cover For Use with 5-5/8" Slab	E9-7723		Door Jamb Adaptor Subframe	E9-2344
	7-3/8" Slab Edge Cover For Use with 6-3/8" Slab	E9-8223		4-1/2" x 1-3/4" Door Head	AS-0402
	7-7/8" Slab Edge Cover For Use with 7-7/8" Slab	E9-8231		Flat Filler Use with BE9-2765	BY7-9241

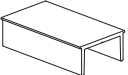
ACCESSORIES

	Head Anchor 10" Cut Length, for Non-Impact Glazing	E1-1190		Jamb Strap Anchor 6" Cut Length For YWW 50 T	E1-1143
	Strap Anchor 10" Cut Length For YWW 60 TU	E1-1191		Jamb Strap Anchor 6" Cut Length For YWW 60 T	E1-1149
	Anchor Filler 4" Cut Length For YWW 60 TU	E1-1194		Door Jamb Mullion Anchor (1-7/8")	E1-1195

ACCESSORIES (Continued)

	Door Jamb Anchor (3-5/8")	E1-1199		End Cap For E9-8428 Slab Edge Cover Plate	E1-9956
	End Dam For YWW 50 TU Sill Flashing	E1-1141		Splice Sleeve For Sill Flashing at Slab Edge	E1-9959
	End Dam For YWW 60 TU Sill Flashing	E1-1142		Head Receptor Splice Sleeve (YWW 50 TU) For BE9-2819	E1-2813
	End Cap (YWW 50 TU) For BE9-7635 & BE9-8426 Head Receptor	E1-9841		Head Receptor Splice Sleeve (YWW 60 TU) For BE9-7299	E1-9824
	End Cap (YWW 50 TU) For BE9-2819 Slab Edge Head Receptor	E1-9952		Head Receptor Splice Sleeve For Slab Edge	E1-9961
	End Cap (YWW 60 TU) For BE9-7736 Head Receptor	E1-9855		Silicone Splice Sleeve	E2-0070
	End Cap (YWW 60 TU) For BE9-7299 Slab Edge Head Receptor	E1-9822		Flat Filler PVC For YWW 50 TU	E3-0032
	End Cap For Slab Edge Sill Flashing Adaptor	E1-1196		Flat Filler PVC For YWW 60 TU	E3-0023
	End Cap For E9-8059 Slab Edge Cover Plate	E1-9984		PVC Perimeter/Pocket Filler	E3-3664
	End Cap For E9-7723 Slab Edge Cover Plate	E1-9985		Airtight Gasket	E2-0051
	End Cap For E9-8223 Slab Edge Cover Plate	E1-9953		Weather Seal Gasket For Mullion Halves	E2-7010
	End Cap For E9-8231 Slab Edge Cover Plate	E1-9954		Weathering Gasket For Slab Edge Cover	E2-0065
	End Cap For E9-8589 Slab Edge Cover Plate	E1-9955		Anti-Walk Block For Female Mullion	E2-0546

ACCESSORIES (Continued)

	Side Block For Male Mullion	E2-0133		Drill Fixture	H-7264
	Setting Block	E2-0150		#10" x 3/8" PHMS Stainless Steel, For Corner Cover Attachment	PM-1006 -SS
	Side Block for Jamb	E2-0628		#12 x 3/4" UFHMS Type A , Zinc Plated Steel, For End Dam Attachment	UA-1212
	Setting Block for Top of Glass	E2-0068		#12 x 1" FHSMS Type AB , Used with E1-1192 Strap Anchor	FC-1216
	Setting Block for Intermediate Horizontals	E2-0178		#12 x 1-1/2" FHSMS Type AB , Zinc Plated Steel, Used at Female Mullion at Door Jamb	FC-1224
	Setting Block For Slab Edge Cover	E2-0054		#12 x 2-1/2" FHSMS Type AB , Used at Door Transom Bar	FC-1240
	Water Deflector	E2-0047		#12 x 5/8" PHSMS Type AB , Zinc Plated Steel	PC-1210
	Foam Backer Tape 1" x 1-1/4" (Roll)	E2-0259		#12 x 1" PHSMS Type AB , Zinc Plated Steel, Used at Male Mullion at Door Jamb	PC-1216
	1/4" x 1/4" Spacer Tape	E2-0110		#12 x 1-1/4" PHSMS Type AB , Zinc Plated Steel	PC-1220
	Dart Gasket 1/4" F.C.	E2-0801		#25 x 1/2" PHMS , Stainless Steel	PM-2508- SS
	Wedge Gasket 1/4" F.C.	E2-0808		"This Side Down" Static Label	E4-0008
	Weep Baffle	E2-0099			

FRAME FABRICATION

STEP 1 DETERMINE FRAME SIZE

Determine Frame Width:

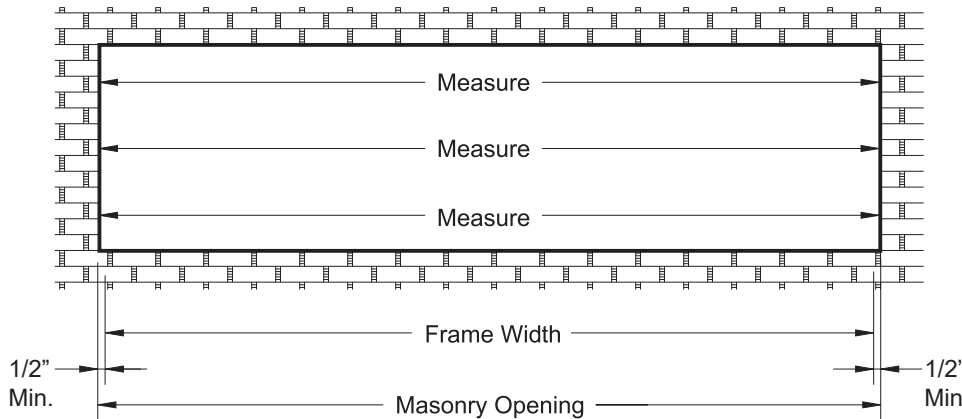

Note: Check opening for squareness of plumb at both ends, units must be installed in a true rectangle.

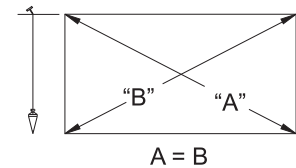

DETAIL 1

- Measure the width of the masonry opening at the top, middle, and bottom.
 - Select the smallest dimension measured and subtract 1" to determine the frame width.
- See **Detail 1**.

Note: For additional possibilities such as slab edge cover application, it is recommended to increase the caulk joint at the jambs to facilitate installation of the last framed unit. (Unit width will proportionally affect caulk joint width.)

Determine Frame Height:

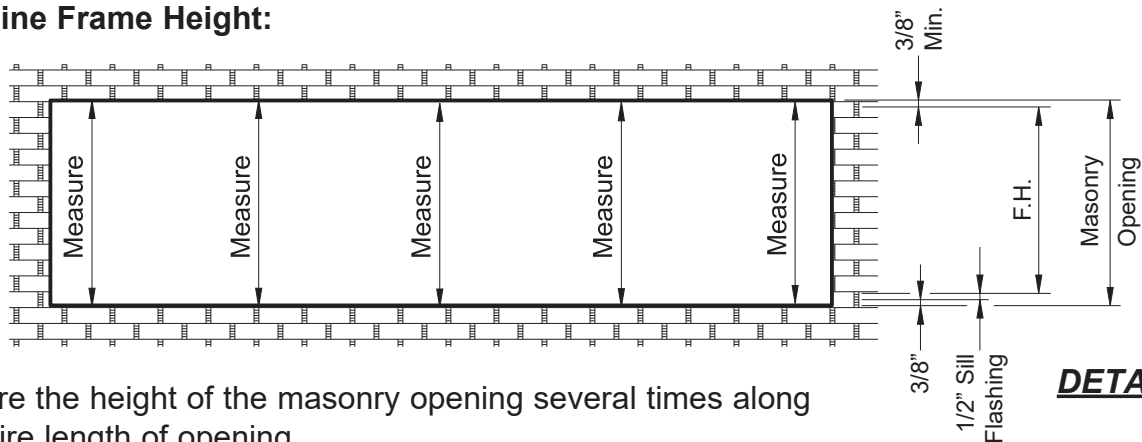

DETAIL 2

- Measure the height of the masonry opening several times along the entire length of opening.
- Select the smallest dimension measured and subtract *1-1/4" to determine the frame height to be used.

Minimum of 3/8" shim/caulk joint at the head.

1/2" for the sill flashing.

Minimum 3/8" shim/caulk joint below the sill flashing.

See **Detail 2**.

* **Note:** 1-1/4" is based on 3/8" perimeter caulk joint, which can vary per project.

FRAME FABRICATION

STEP 1 (Continued) DETERMINE FRAME SIZE

Determine Frame Height for Slab Edge Conditions:

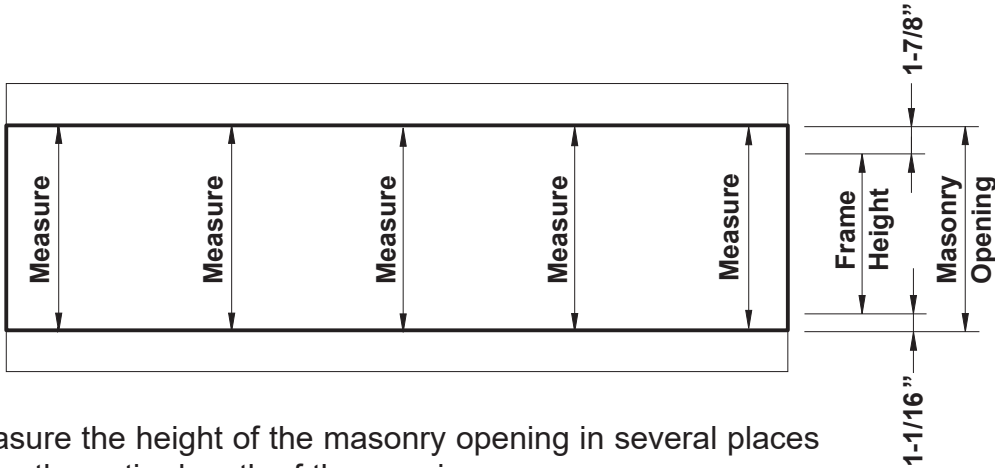

- Measure the height of the masonry opening in several places along the entire length of the opening.
- Select the smallest dimension measured and subtract $*2-15/16"$ to determine the frame height to be used:
 - $5/8"$ for the shim/caulk joint at the head.
 - $1-1/4"$ for the head receptor.
 - $7/16"$ for the sill flashing.
 - $5/8"$ for the shim/caulk joint below the sill flashing.

Detail 3

See **Detail 3**.

* **Note:** $2-15/16"$ is based on $5/8"$ perimeter caulk joint, which can vary per project.

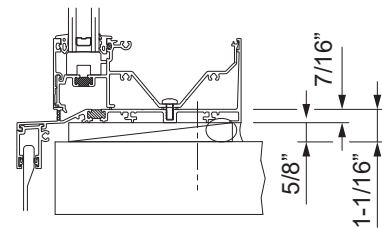
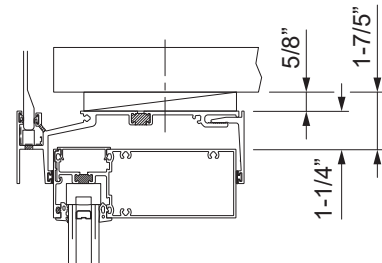

FRAME FABRICATION

**STEP 2
FABRICATE VERTICAL MEMBERS**

- Cut all jamb and two piece vertical members to the frame height determined in **Step 1**.
- Fabricate holes in the vertical members for screw spline attachment using one of the methods below:
 - Using the H-7264 drill fixture as a template, line up the glazing pockets and mark hole locations through the screw splines of the templates.
- OR**
- Layout hole locations on vertical members as shown in **Detail 4**.
- Drill 0.236" diameter (#B drill bit) holes at each location marked.

Notes: Drill fixture plate can be used. Additional fabrication will be required for the inclusion of steel reinforcing.

* A 5/16" diameter access hole can be used at the very top to eliminate sharp edges.

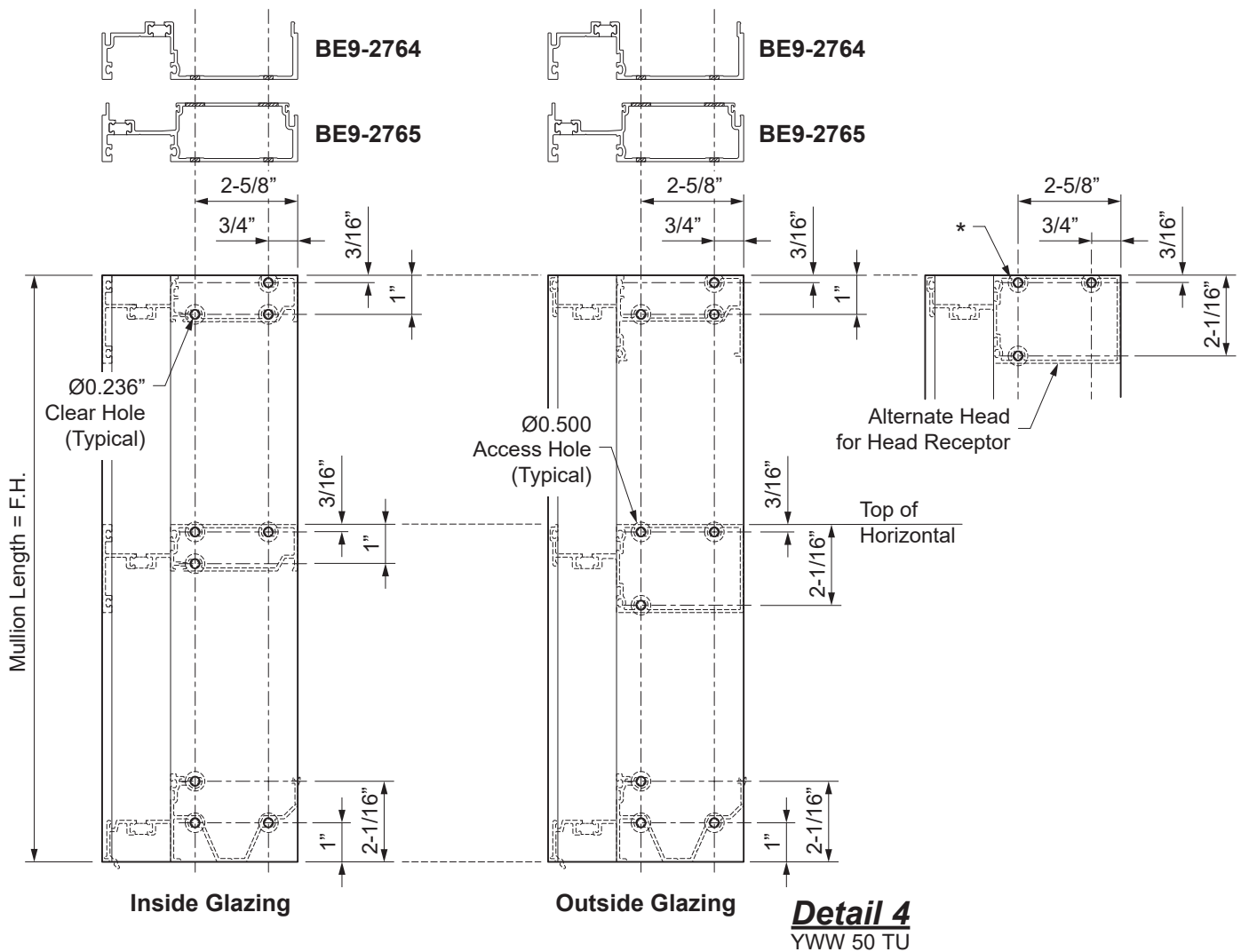

FRAME FABRICATION

**STEP 2 (Continued)
FABRICATE VERTICAL MEMBERS**

-For hollow vertical members, fabricate access holes in addition to the clear holes according to the methods previously shown and in **Detail 5**.

Notes: Additional fabrication will be required for the inclusion of steel reinforcing.

* A 5/16" diameter access hole can be used at the very top to eliminate sharp edges.

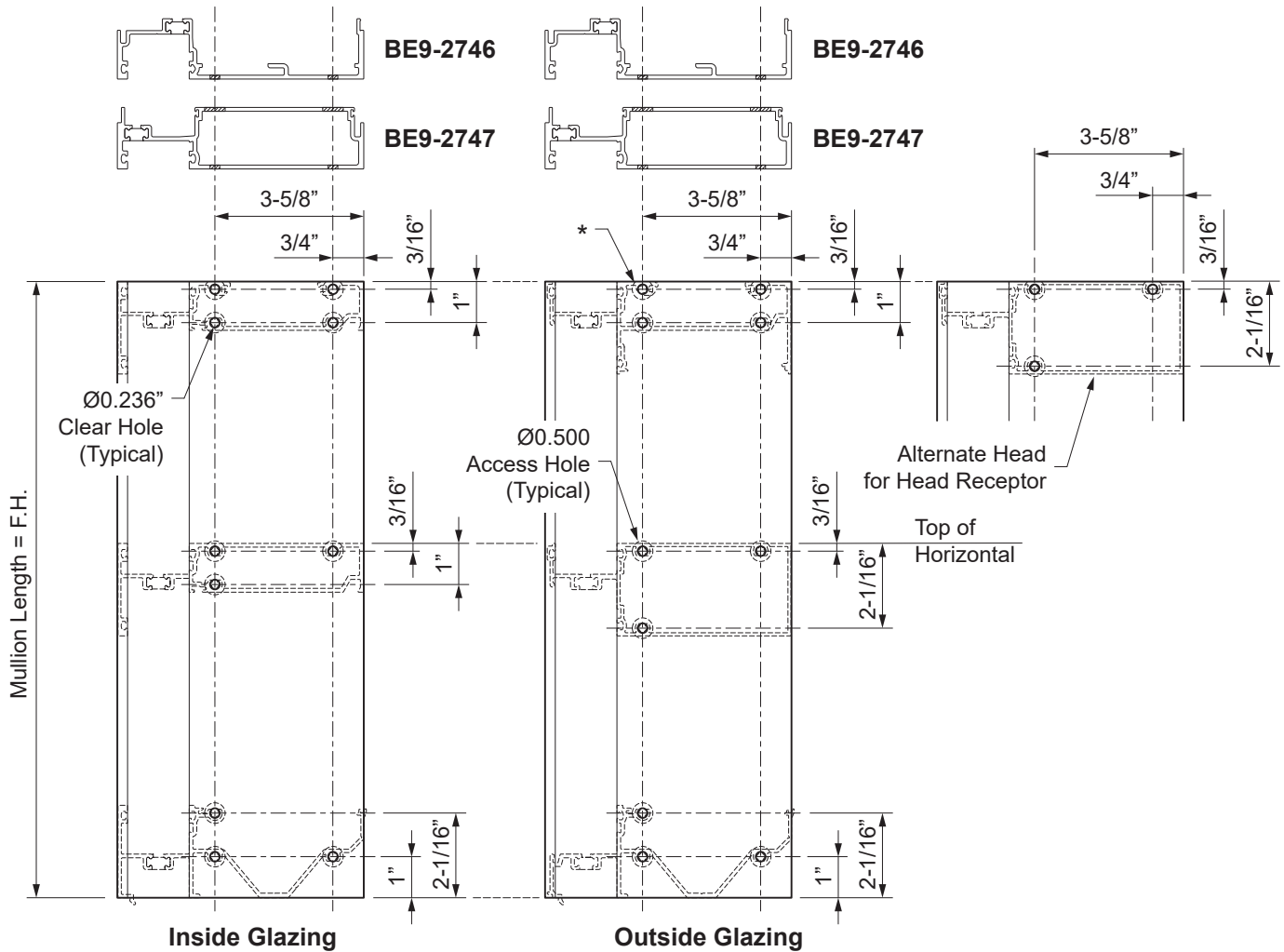

Detail 5
YWW 60 TU

FRAME FABRICATION

STEP 3
FABRICATE HORIZONTALS

- Cut all horizontals, head, and sill members to the horizontal daylight opening.
- Head and intermediate horizontal members will require 0.189" diameter holes for the glass stops, at 2" from the ends and one at the midpoint, as shown in **Detail 6**.
- Sill members will require additional 0.281" diameter clear hole at 3" from the ends of the daylight opening, centered along the V-groove as shown in **Detail 6**.

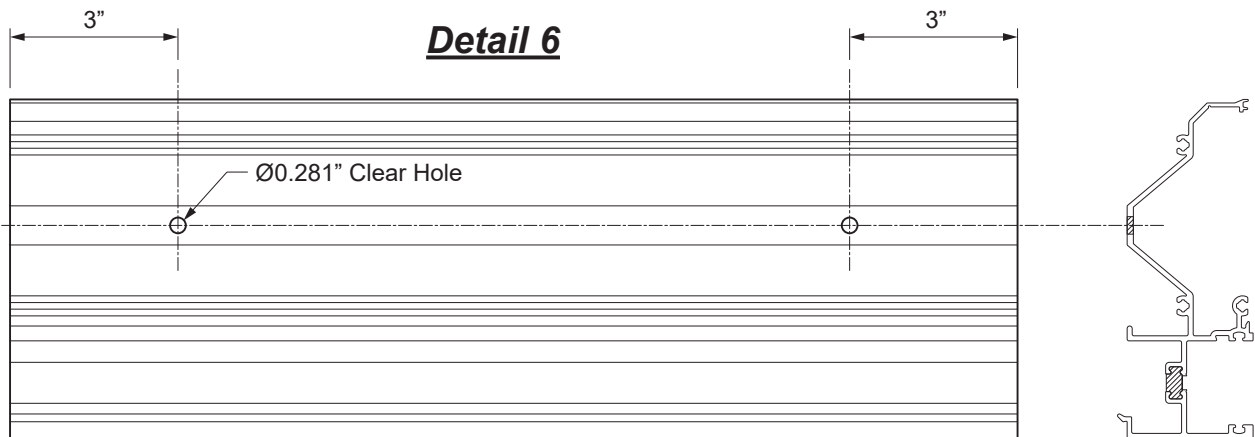
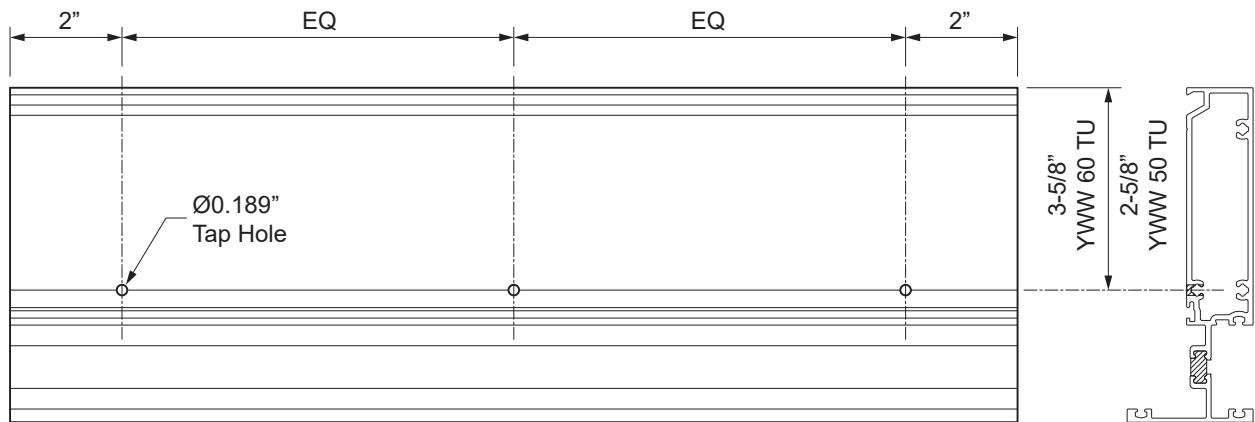
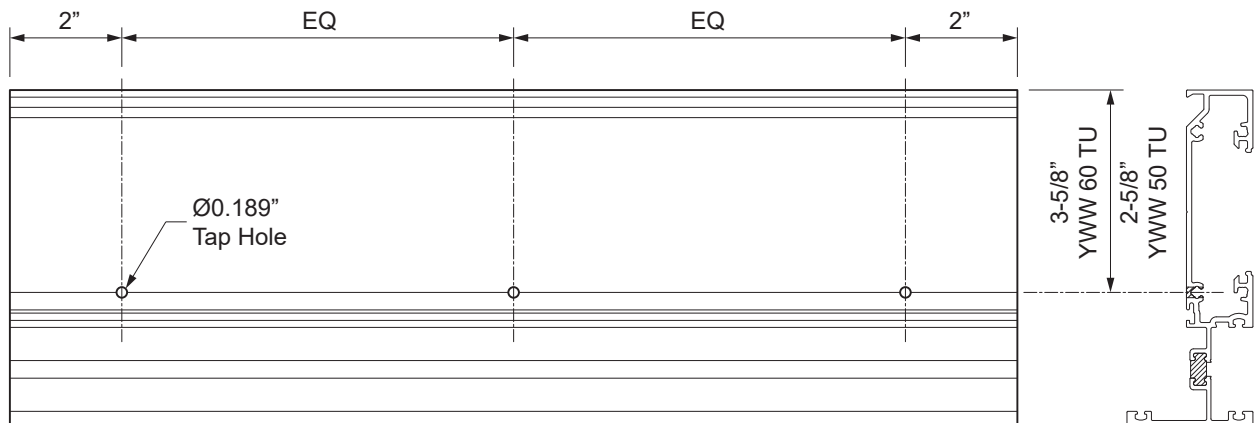

FRAME FABRICATION

**STEP 3 (Continued)
FABRICATE HORIZONTALS**

When the head is anchored to the substrate with the E1-1190 anchor, access holes will need to be drilled into the head member.

- Temporarily clamp the E1-1190 anchor onto the head where it will be in relation to the head member once anchored to the substrate.
- Drill 5/16" diameter holes into the head in line with the holes in the anchor. Unclamp the anchor. Then drill the access holes out to 3/4" diameter.

Notes: This is in addition to the 0.189" diameter tap holes for the glass stop. Refer to FPA drawings or shop drawings for appropriate fastener and hole locations as determined by a qualified engineer.

See **Detail 7**.

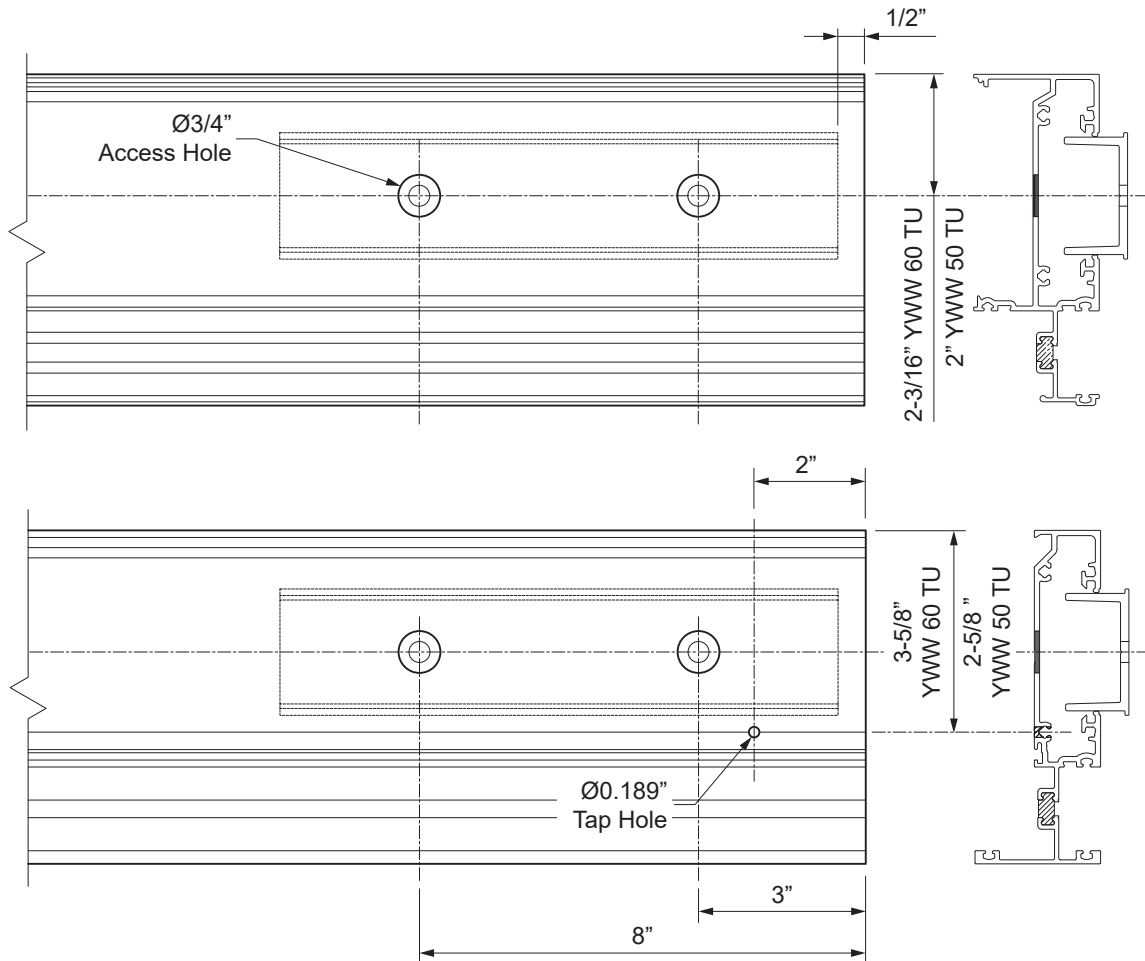

Detail 7

FRAME FABRICATION

STEP 4
FABRICATE FILLERS & GLASS STOPS

- Cut all vertical perimeter PVC fillers to the length of the jambs, except where strap anchors would interfere with the jamb filler.
- Cut all horizontal flush fillers, flat fillers, and interior covers to horizontal daylight opening minus(-) 1/32".

See **Detail 8**.

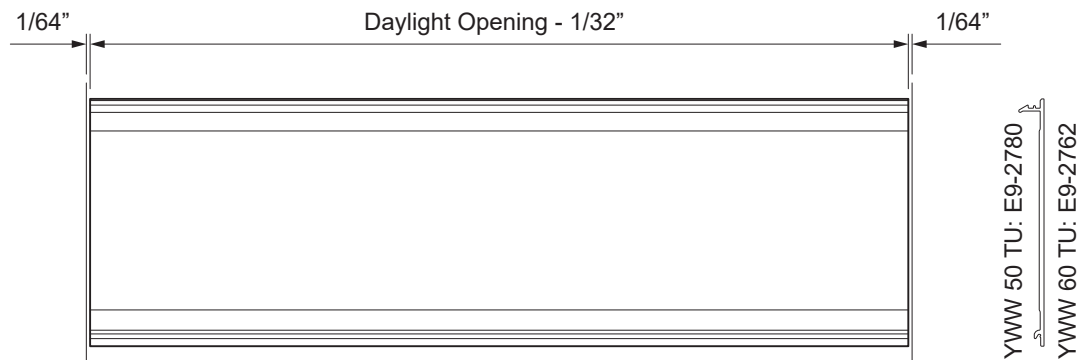

Detail 8

- Cut E9-7852 glass stops to horizontal daylight opening minus(-) 1/8". Drill two 0.236" diameter clear holes along the v-groove in the glass stop as shown in **Detail 9**.
- Add a third hole at centerline for glass stops over 48" in length.

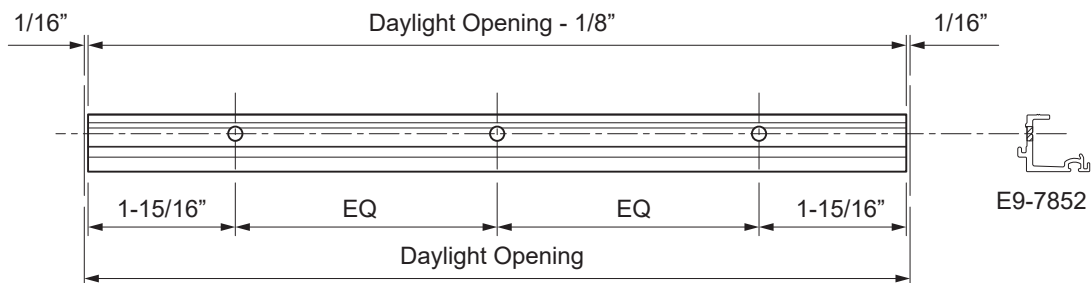

Detail 9

FRAME FABRICATION

**STEP 5
FABRICATE SILL FLASHING**

-Cut the sill flashing to the frame width plus(+) 5/16" at each jamb.

Note: For additional possibilities such as slab edge cover application, it is recommended to provide additional space between the edge of the sill flashing and the jamb substrate.

-For frame openings longer than 24'-0", allow for a 3/8" splice joint between sill flashing members every twelve to fifteen feet at the center of a daylight opening (best location next to the door jamb.)

-Mark the front face of the sill flashing at the center of each vertical location and the midpoint of the daylight opening between the verticals.

-Drill a 5/16" diameter weep hole in the face of the sill flashing at each location marked.

See **Detail 10**.

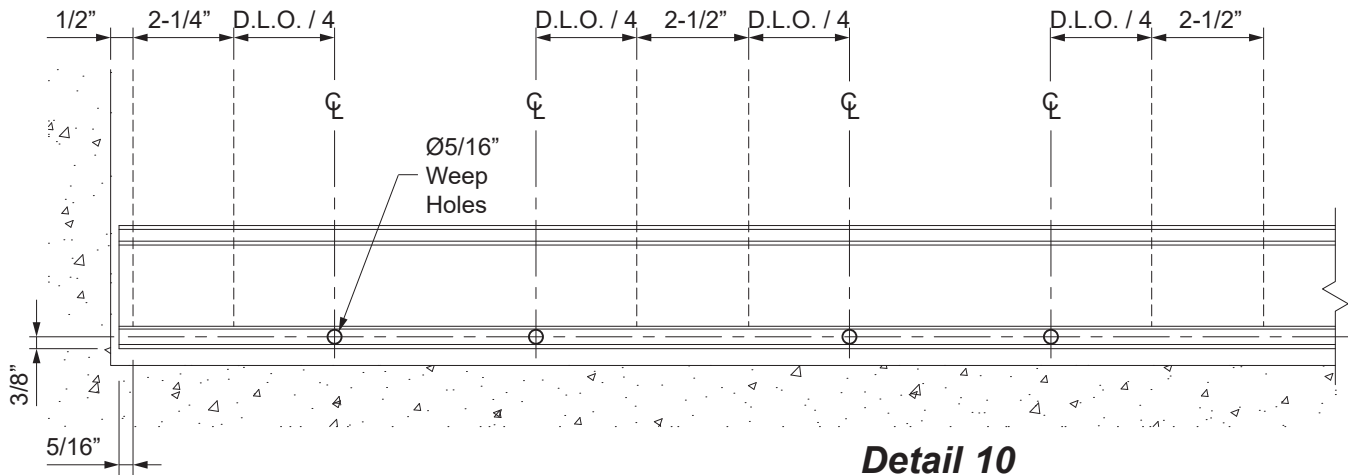

Detail 10

Additional fabrication will be required for BE9-2775 and BE9-2757 sill flashings used at slab edge covers if splices are needed.

-Notch the sill flashing as shown in **Detail 11**.

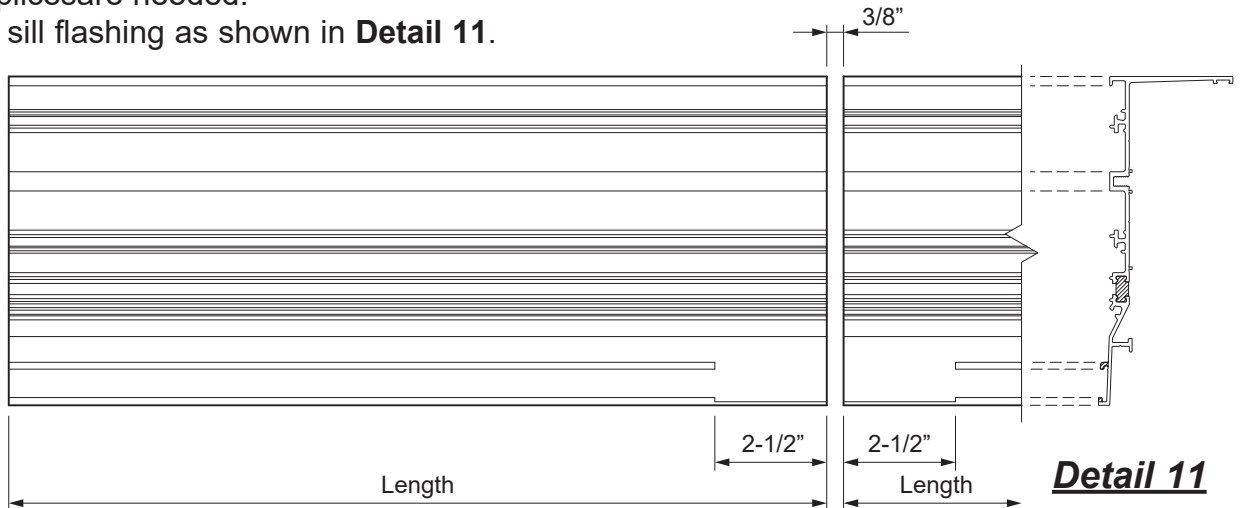

Detail 11

FRAME FABRICATION

**STEP 5A
FABRICATE SLAB EDGE PLATE ADAPTOR**

- Cut the aluminum plate adaptor E9-8222 to the same length as the sill flashing.
- Notch the aluminum plate adaptor 2-1/2" from each end at each splice joint location as shown in **Detail 12**.
- Cut slab edge cover plates to length as indicated on the approved shop drawings

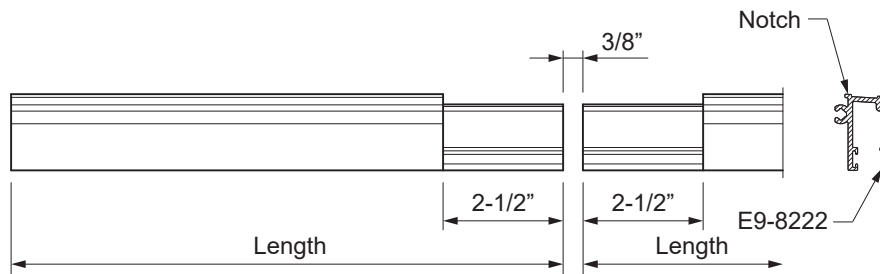

Detail 12

**STEP 6
FABRICATE CORNER COVERS**

- Cut the corner cover components to the mullion length. Drill 0.213" diameter holes into the cover at the v-groove where the cover will be fastened to the mullion at 3" from each end and at 24" maximum on center.

See **Detail 13**.

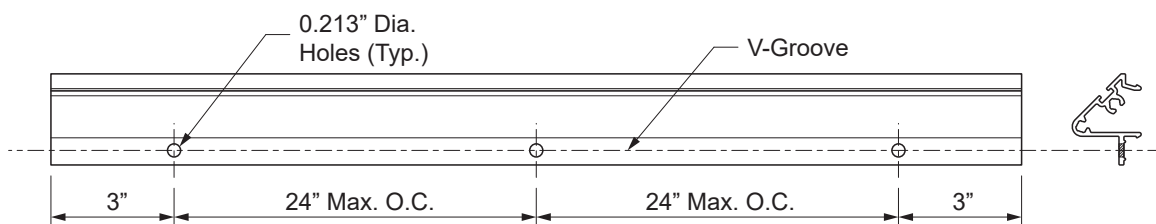

Detail 13

E9-2741 Shown,
Others Similar

FRAME FABRICATION

**STEP 7
FABRICATE HEAD RECEPTOR**

-Cut the head receptor to the frame width plus(+) 5/16" at each jamb.

Note: For additional possibilities such as slab edge cover application, it is recommended to provide additional space between the edge of the head receptor and the jamb substrate.

- For frame openings longer than 24'-0", allow for a 3/8" splice joint between sill flashing members every twelve to fifteen feet at the center of a D.L.O.
- Mark the front face of the head receptor at the center of each vertical location and the midpoint of the daylight opening between the verticals.
- Drill a 1/4" diameter weep holes in the head receptor at each location marked.
- Drill clear holes for anchor fasteners into the head receptor as indicated on the approved shop drawings and or P.E. calculations.

See **Detail 14**.

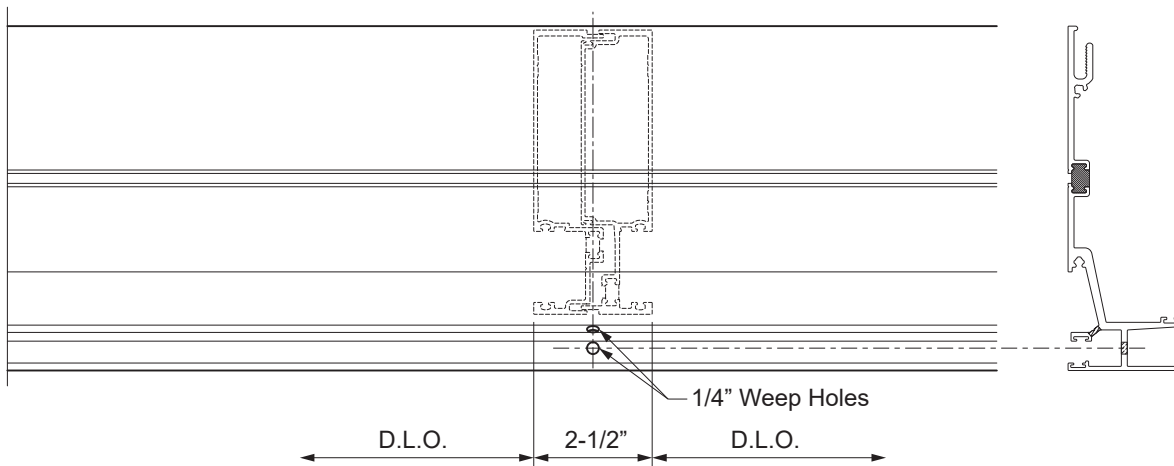

Detail 14

**STEP 8
FABRICATE 1/4" GLAZING ADAPTORS (Where Required)**

- Cut the vertical glazing adaptor to daylight opening dimension plus(+) 7/8".
- Cut the horizontal glazing adaptor to daylight opening dimension minus(-) 1/32".

FRAME ASSEMBLY

**STEP 9
ASSEMBLE FRAME**

Note: It is recommended to lay out the unit pieces face up on a table or saw horses during assembly, fully supporting the mullions. If using saw horses, a brace tying the two together will be required.

- If strap anchors are used at the head, insert them into the head member prior to assembly (2 per Daylight Opening, unless otherwise noted).
- Apply sealant to the end of the horizontal members to be attached to the first mullion or jamb, at the shaded areas of the head and intermediate horizontals and the entire end of the sill.

See **Detail 15**.

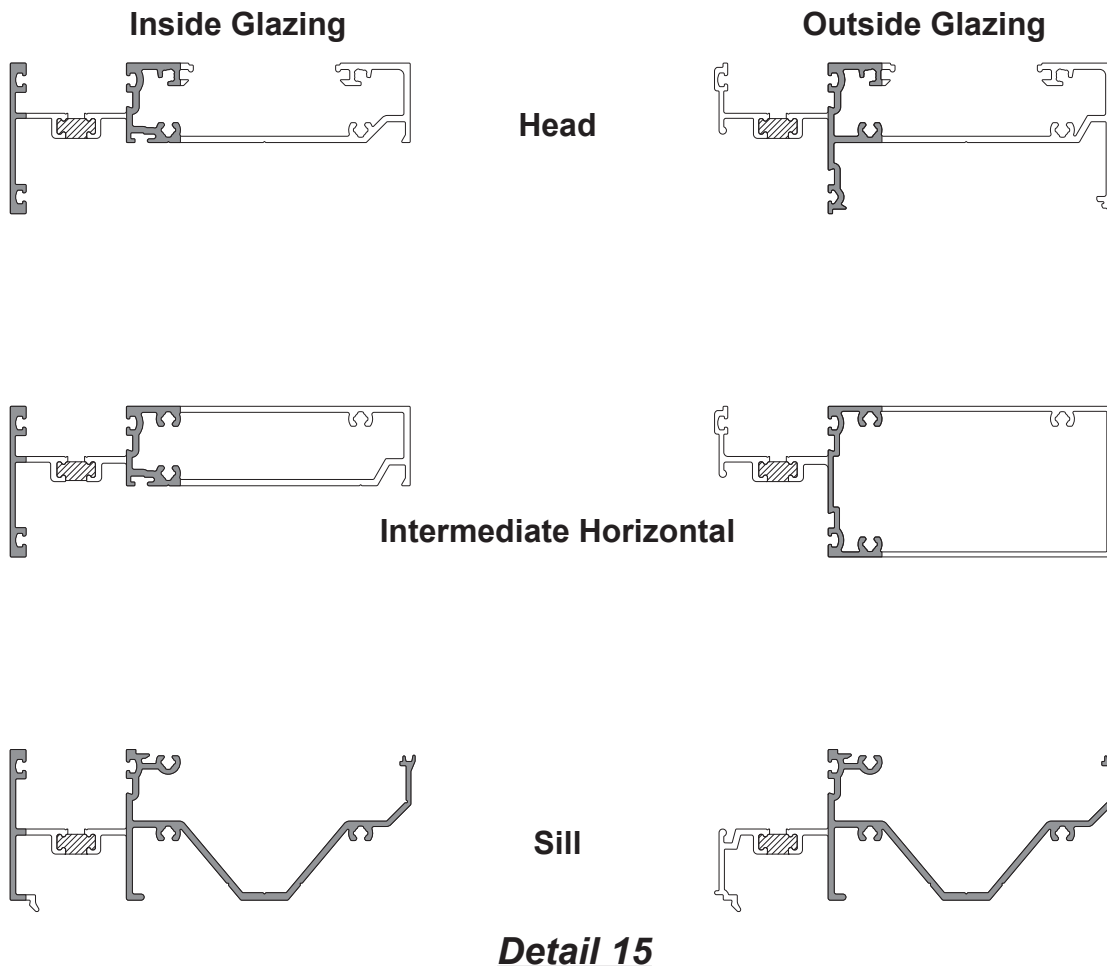

FRAME ASSEMBLY**STEP 9 (Continued)
ASSEMBLE FRAME**

-Attach the horizontal members to the first mullion or jamb using PC-1220 screws, ensuring the bottom and back of the sill aligns with the bottom and back of the mullion as shown in **Detail 16A**.

See **Detail 16** .

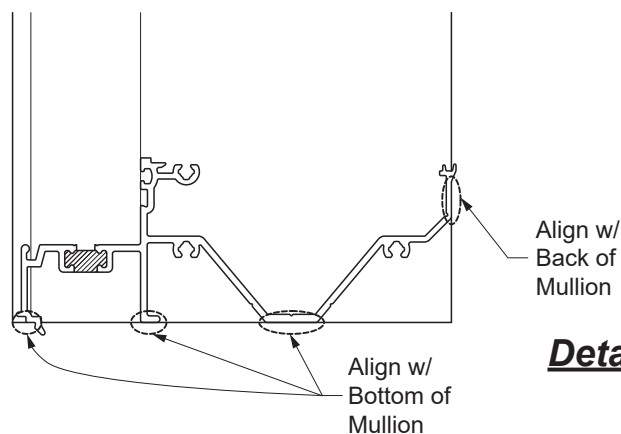
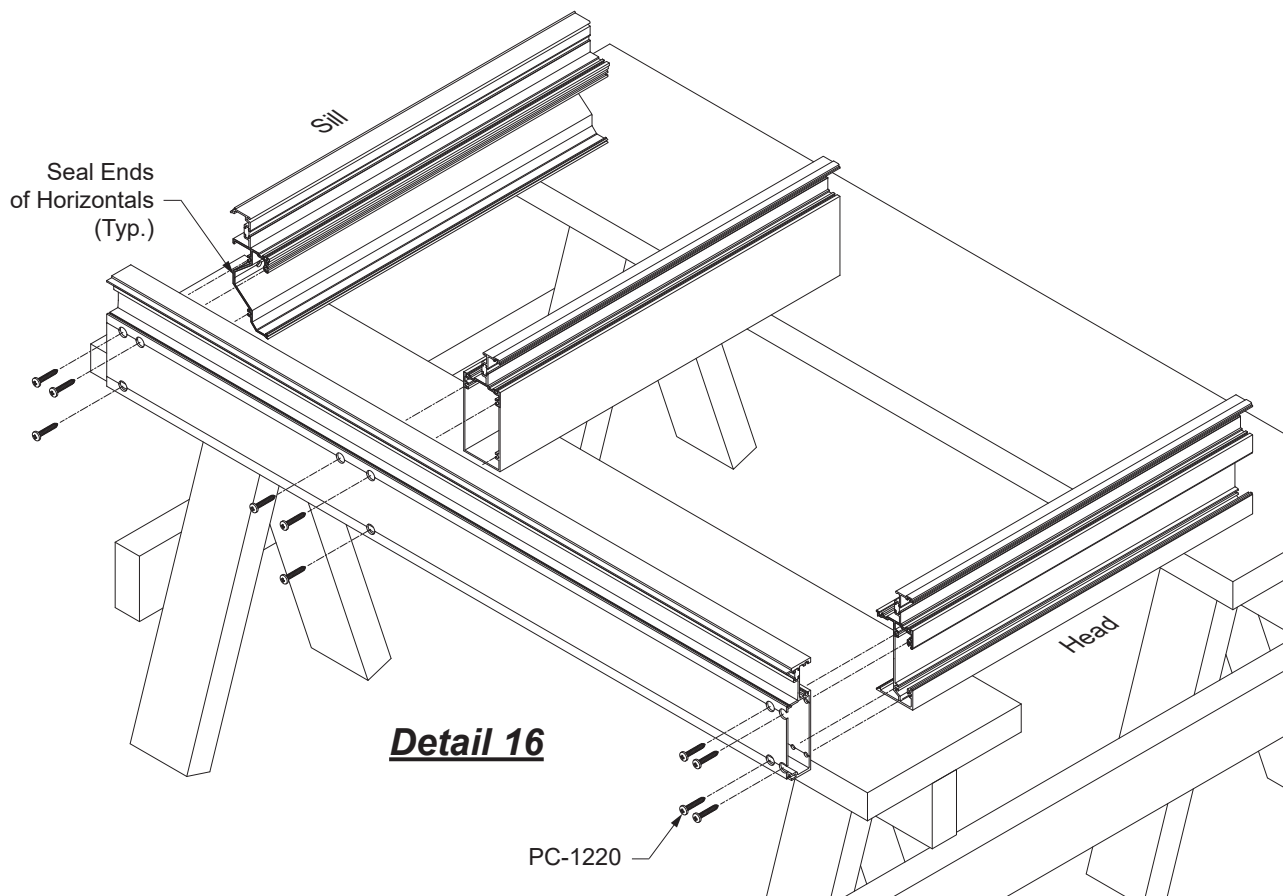

FRAME ASSEMBLY

STEP 9 (Continued)
ASSEMBLE FRAME

- Apply sealant to the end of the head, horizontals, and sill that is to be attached to the second mullion or jamb as previously shown in **Detail 16**, also ensuring proper alignment at the bottom of the mullion.
- Attach the horizontal members to the mullion using PC-1220 screws. See **Detail 17**.

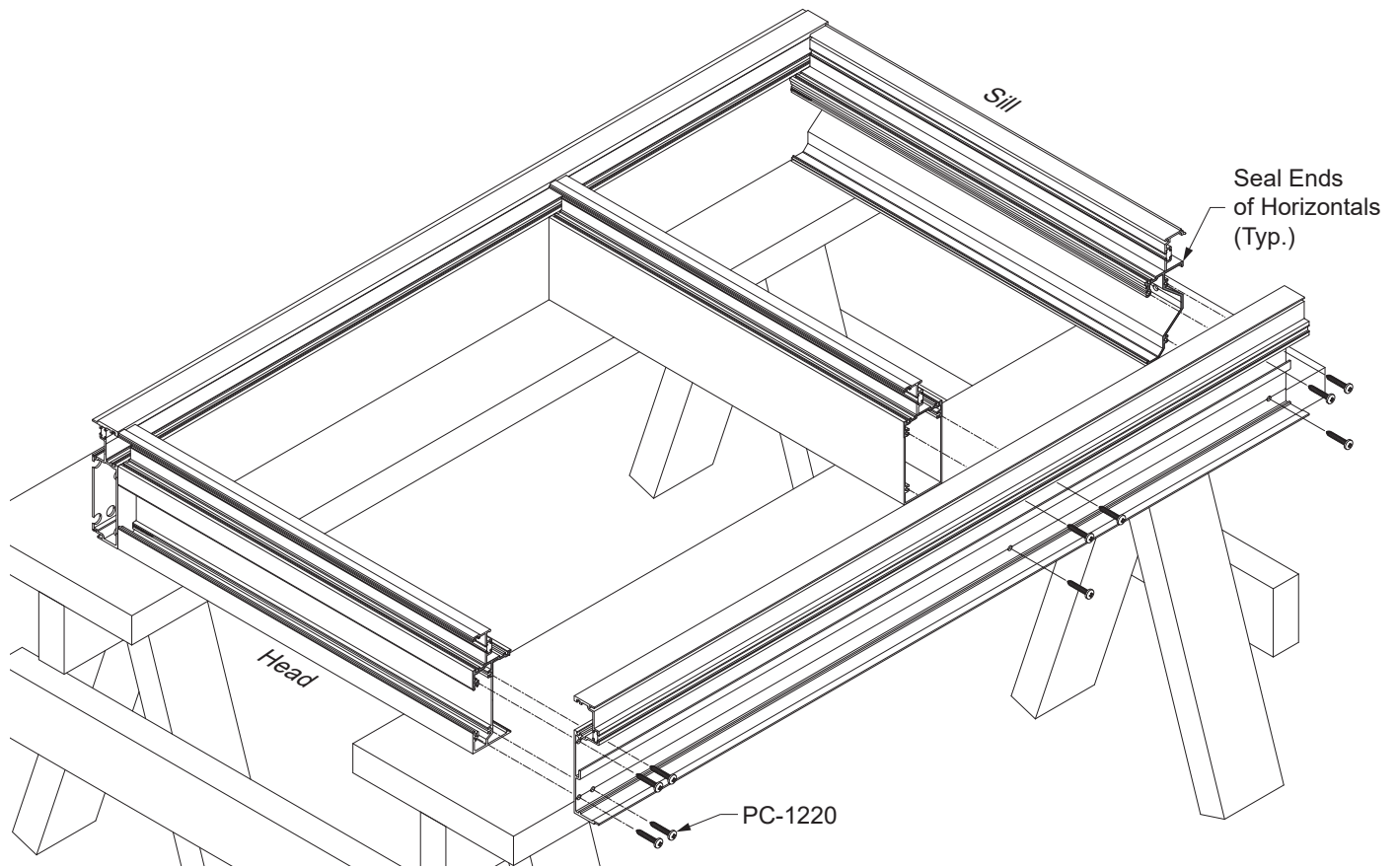

Detail 17
Outside Glazing shown,
Inside Glazing Similar

- For inside glazed units, apply sealant to the inside of the glazing pocket of the horizontal at the verticals as shown in **Detail 17A**.

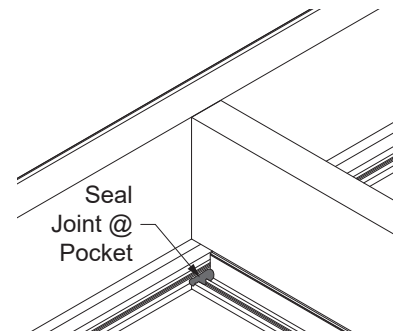

Detail 17A
Inside Glazed
Units Only

FRAME ASSEMBLY

STEP 9 (Continued) ASSEMBLE FRAME -- CORNER MULLION

- Apply sealant to the interior snap interface of the interior corner cover, 6" up from the bottom of the mullion. Snap the cover pieces onto the corner mullion half. Fasten with PM-1006-SS fasteners at the holes previously drilled in fabrication.
- The exterior corner cover will require E2-0051 bulb gaskets cut to the length of the mullion. Apply dabs of sealant to the bottom of the bulb gasket to adhere it to the mullion so that it will not slide out during unit installation. Do not overseal. Insert the gasket into the reglet at the cover.
- The 90° corner cover will also require an E2-0110 spacer tape adhered the cover for one side of the corner. This will keep the covers 1/4" apart. (The other corner half for the adjoining unit will not need this spacer tape.)

See **Details 18** for YWW 50 TU and **Detail 19** for YWW 60 TU.

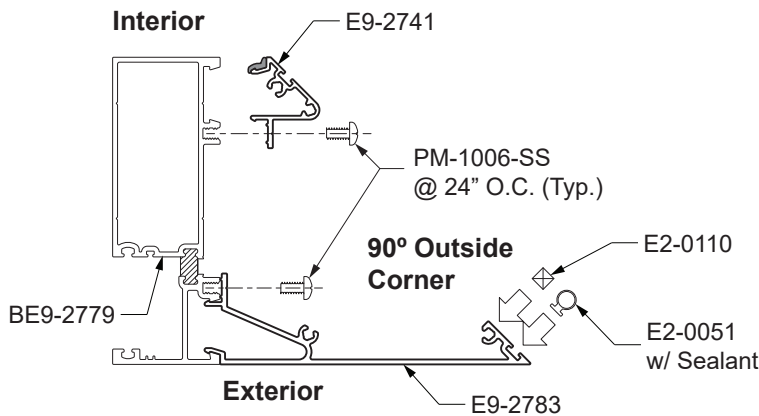

Detail 18
YWW 50 TU

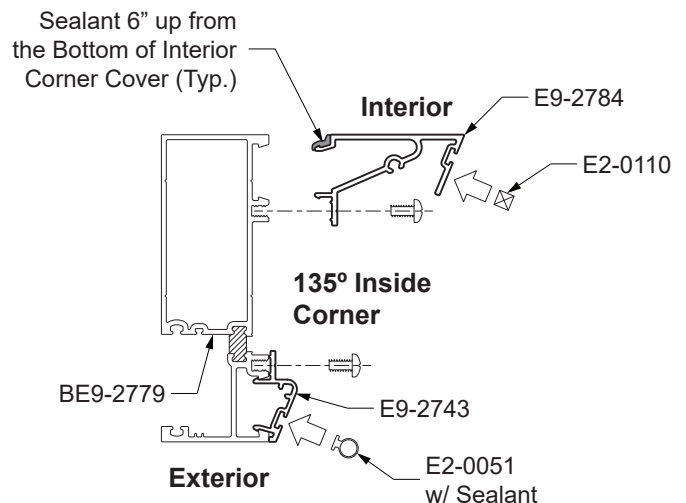
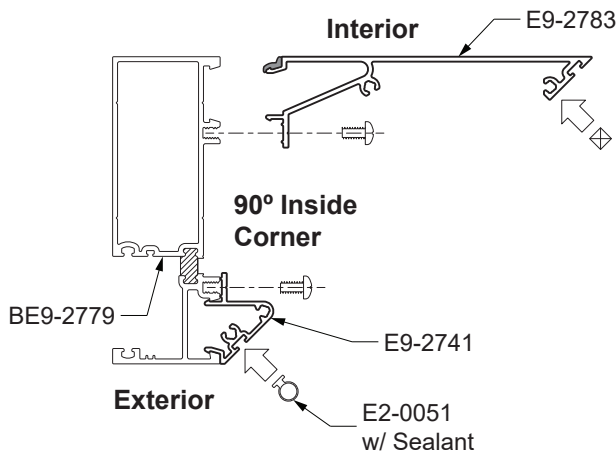
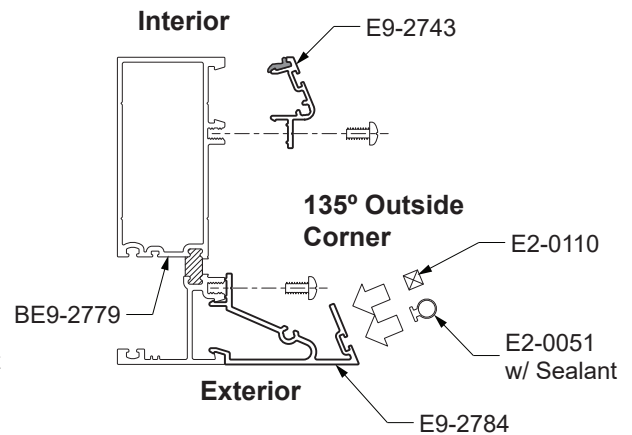

FRAME ASSEMBLY

STEP 9 (Continued)
ASSEMBLE FRAME -- CORNER MULLION

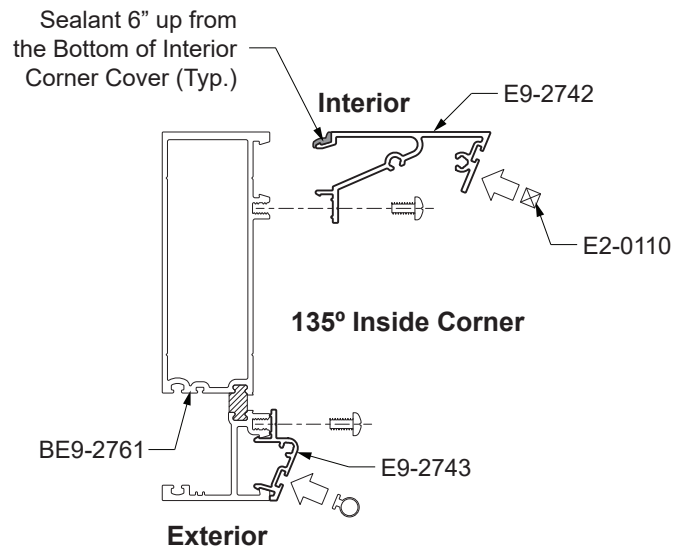
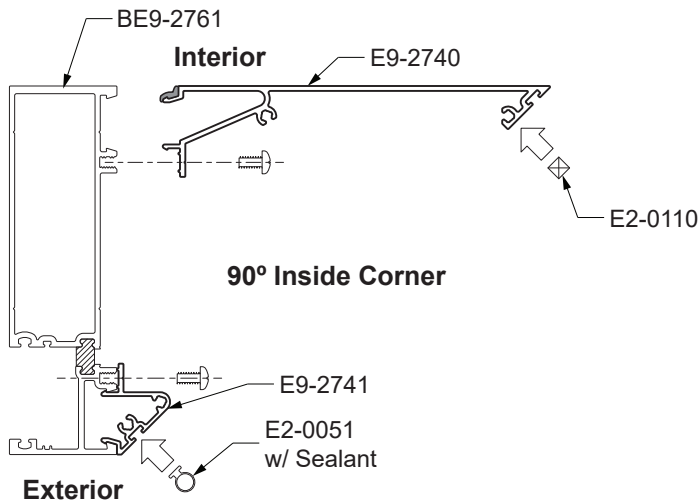
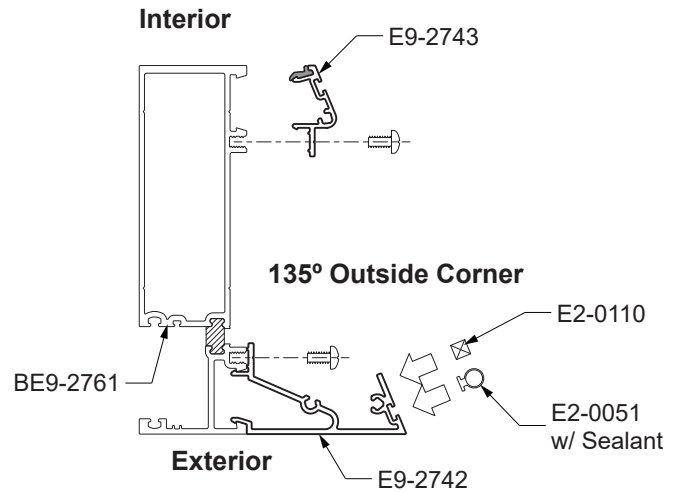
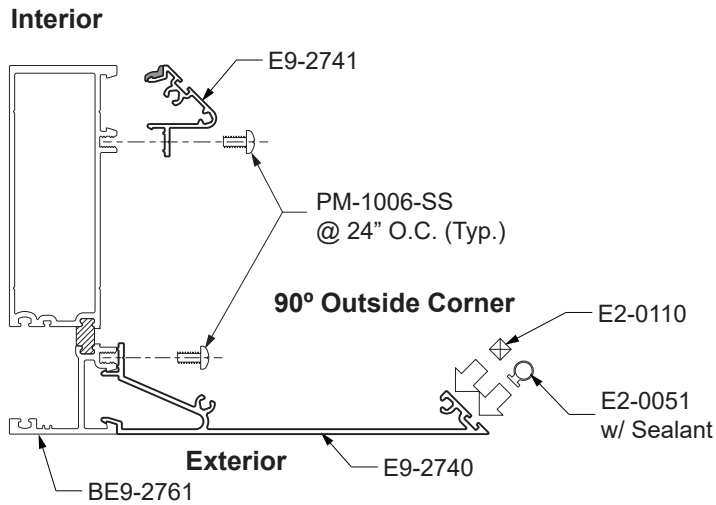

Detail 19
YWW 60 TU

FRAME ASSEMBLY**STEP 10 (Optional)
SECURE UNIT FRAME**

-It may be beneficial to attach bracing to the workspace against the outer edges of the mullions to keep the unit square during the remainder of the assembly process.

See **Detail 20**.

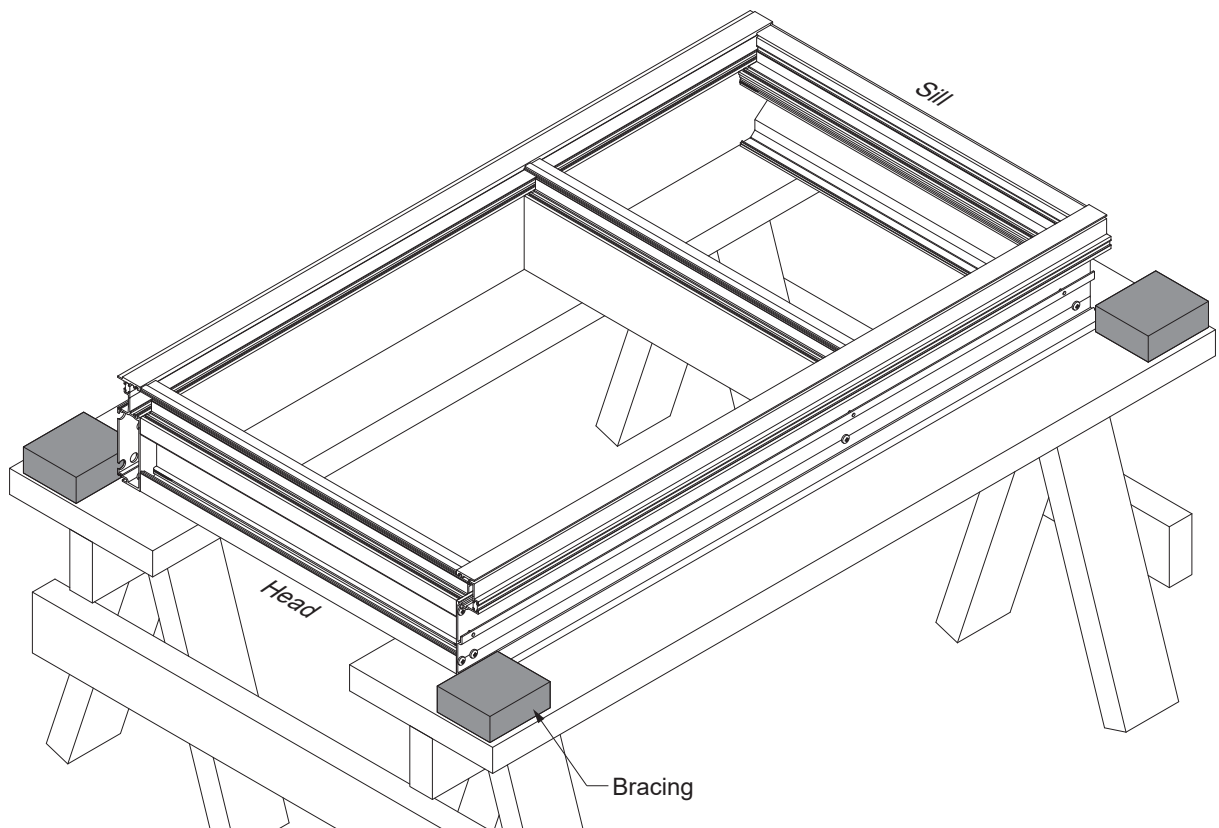

Detail 20

FRAME ASSEMBLY

STEP 11 (Optional)
INSTALL STEEL REINFORCING

- Install steel reinforcing into the mullions and jambs as required by the P.E. calculations and or approved shop drawings.
- Take care that the fasteners do not interfere with the horizontals nor would be visible when the unit is installed.

See **Detail 21**.

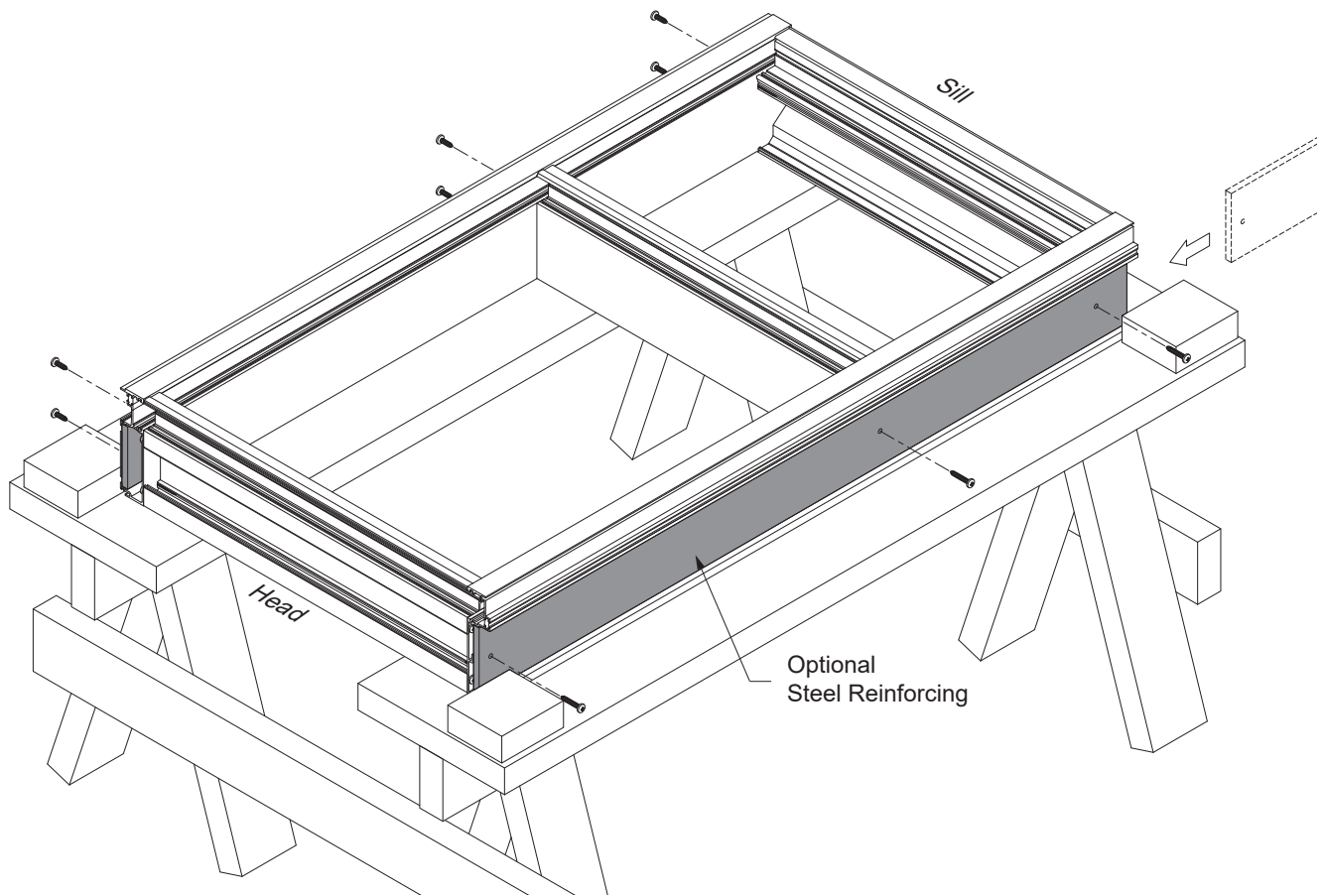

Detail 21

FRAME ASSEMBLY**STEP 12
INSTALL PERIMETER FILLERS**

Install perimeter fillers into the jamb mullions and the head member.
-For the head, cut the E3-3664 pocket filler to horizontal daylight opening minus(-) 1/32" and snap it into the perimeter glazing pocket.

-If jamb strap anchors are used, install them into the jambs prior to installing perimeter fillers.

See **Detail 22**.

-At the jamb, cut the E3-3664 pocket filler to length of vertical and install it into the jamb.

-Cut the flat filler (E3-0032 for YWW 50 TU, E3-0023 for YWW 60 TU) to the length of the jamb, except where strap anchors would interfere. Snap the filler into place.

See **Detail 23**.

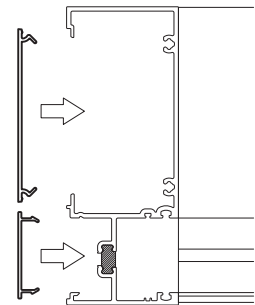

Detail 22

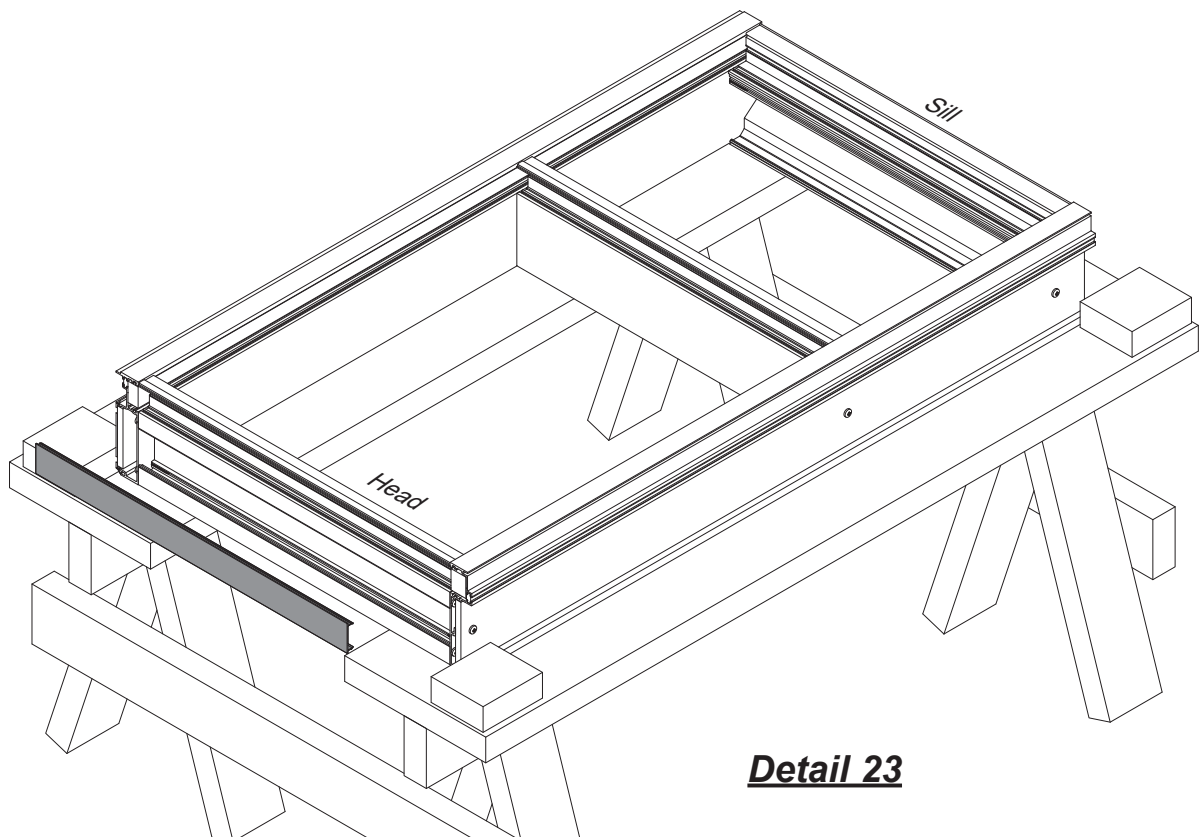

Detail 23

FRAME ASSEMBLY

STEP 13 (Optional, Not Necessary with Head Receptor)
INSTALL FOAM PLUGS AT HEAD

- Cut E2-0259 foam backer tape (maximum 1-1/4" long) to be installed at the head only. These will act as end caps for perimeter backer rods and sealant.
- Peel the adhesive tape from the foam and adhere it to the mullion as shown in **Detail 24**. The foam can be easily compressed around physical obstacles in the assembled verticals.
- In the case where steel reinforcing is present at the head, the foam plugs may be adhered to the steel.

Note: For best adhesion, make sure the contact surfaces of the verticals and or steel members are clean and dry.

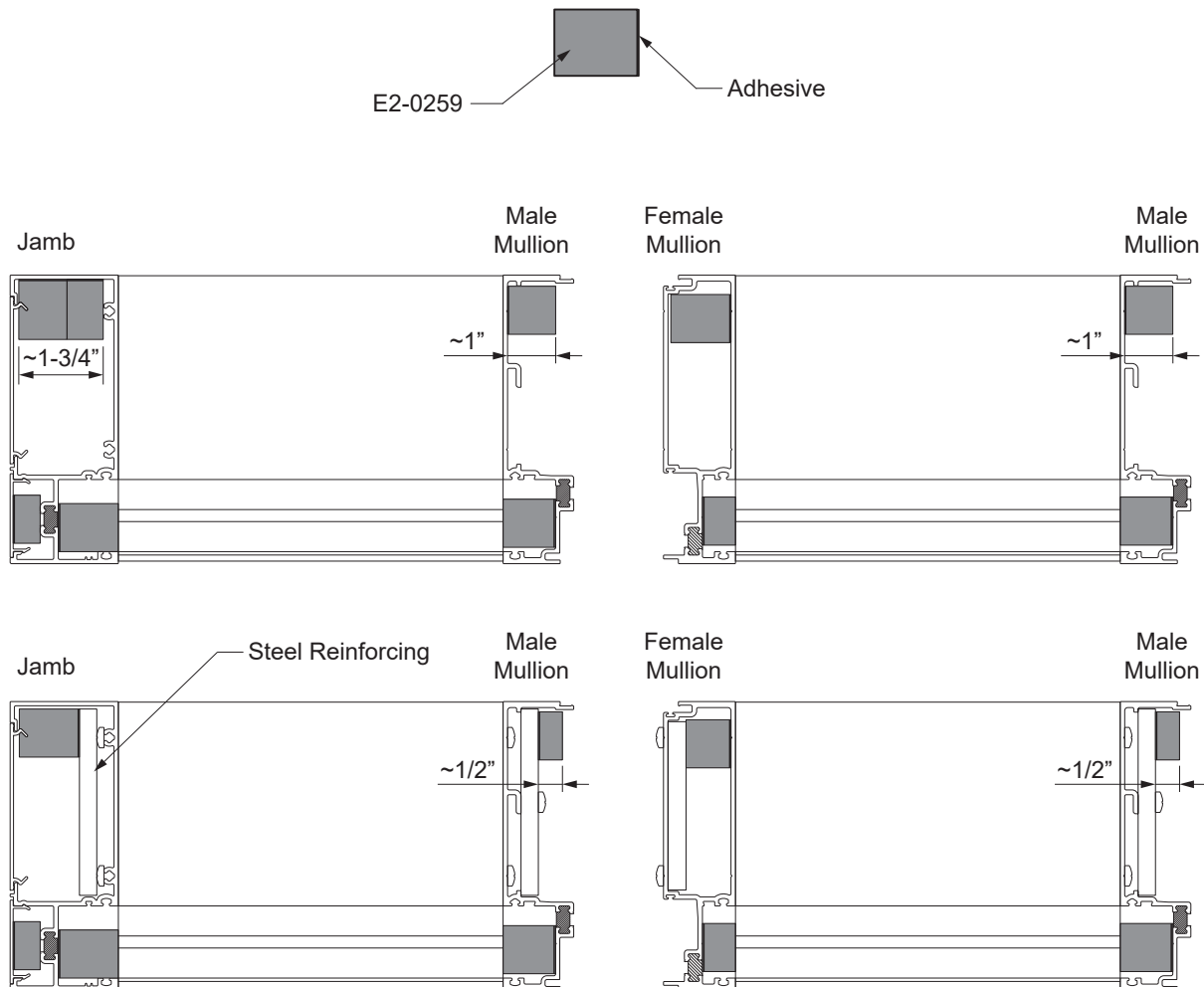

Detail 24

FRAME ASSEMBLY**STEP 14
INSTALL WEATHER SEAL**

Weather seal gaskets (E2-7010) are installed in the female mullion only.

-Cut the weather seal gasket to length of the vertical plus (+) 3", and install into the reglets of the male mullion in the proper orientation as shown in **Detail 25**.

-Apply dabs of sealant to the bottom of the weather seal gasket to adhere it to the mullion so that it will not slide out during unit installation. Do not overseal. Too much silicone will deter mullion engagement.

-Trim the gasket after shrinkage.

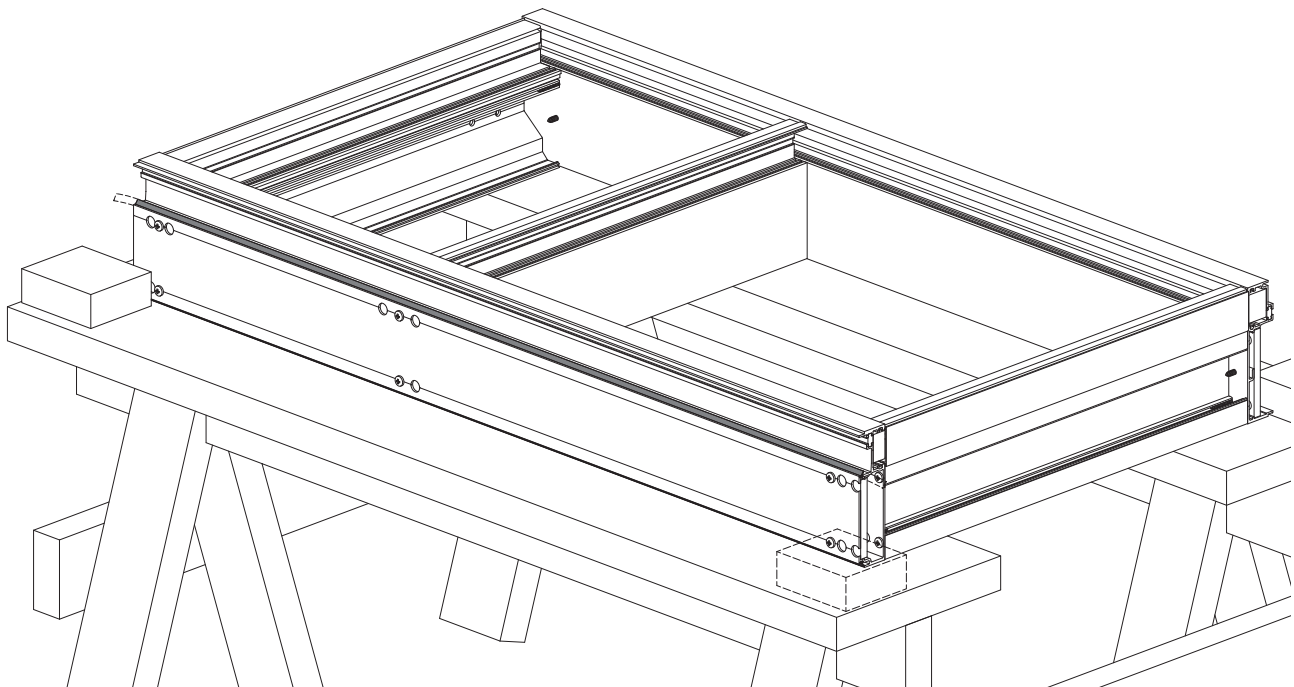
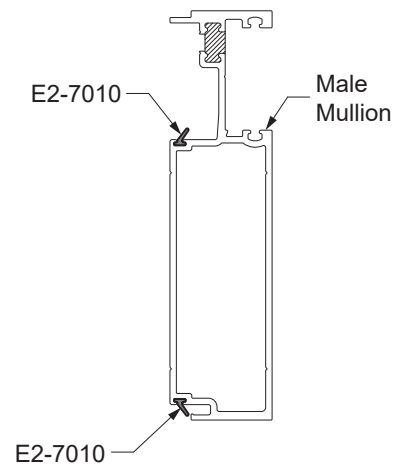

FRAME ASSEMBLY

STEP 15
INSTALL WATER DEFLECTOR

YWW 50 TU and YWW 60 TU require the installation of a water deflector, E2-0047, at the ends of every intermediate horizontal to keep water off of the insulating glass units.

-Peel away the protective paper from the bottom of the water deflector, E2-0047, and install the water deflector at the ends of each horizontal.

See **Detail 26**.

-Position the vertical leg of the water deflector against the end of the horizontal.

Note: For best adhesion, make sure that the horizontal is clean and dry.

-Apply and tool sealant along the edges of the deflector and down onto the horizontal. Seal the ramp of the water deflector to the glazing pocket, filling the gap at the thermal isolator as shown.

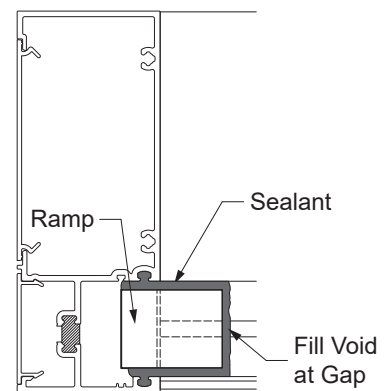

Detail 26

Jamb Mullion shown,
Others Similar

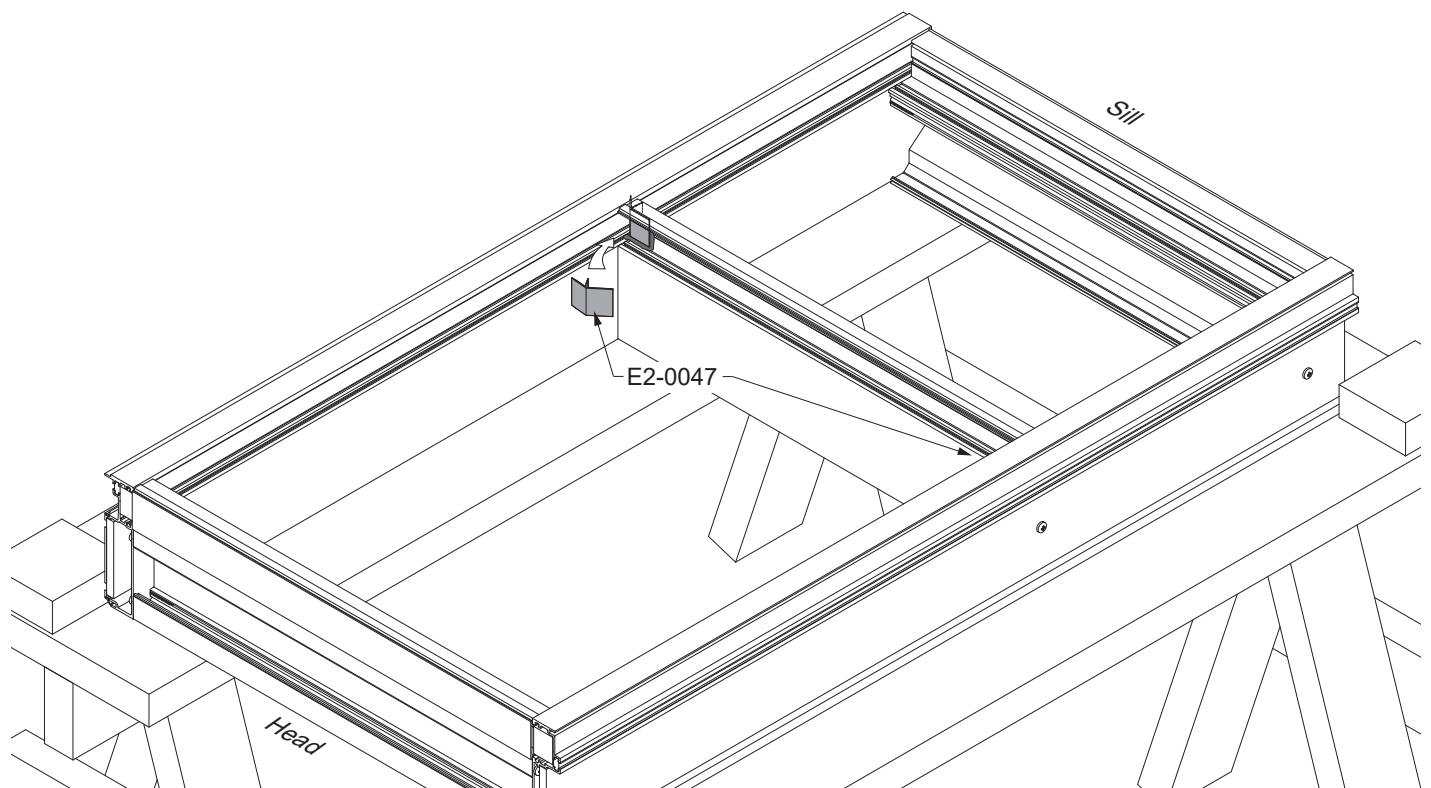

FRAME ASSEMBLY**STEP 16
INSTALL PVC FILLER AT JAMB GLAZING POCKET**

-Insert E3-3664 PVC fillers, cut to 6" long, at the jamb and corner mullions, inside the glazing pocket, at each end of the vertical daylight opening.

See **Detail 27**.

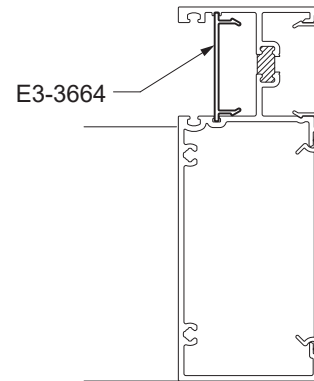

Detail 27
Jamb Mullion Only

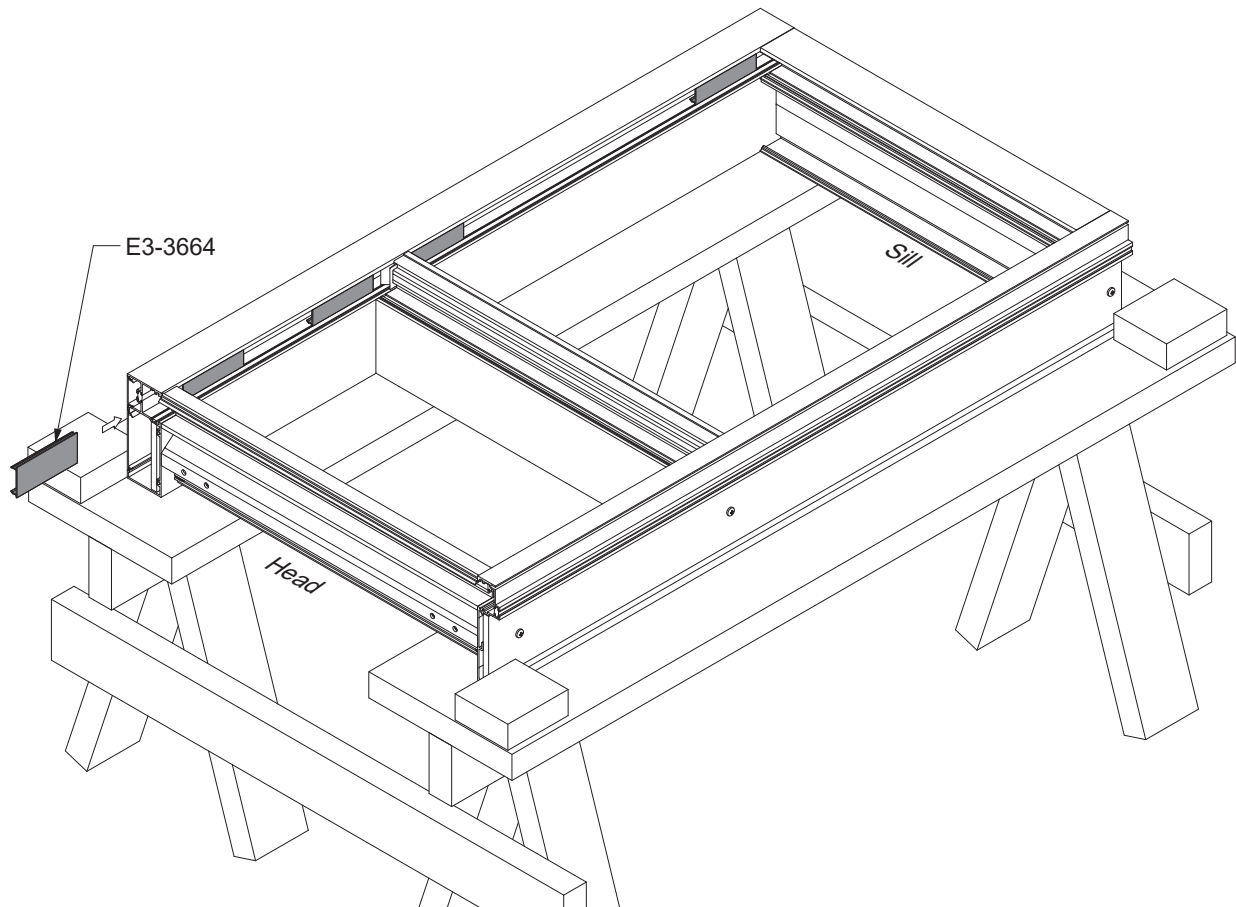

FRAME ASSEMBLY

**STEP 17
INSTALL DART GASKETS**

-Using a small brush, clean out any debris that may have accumulated in the gasket reglets.

Vertical glazing gaskets must be installed first:

- Cut vertical gaskets to the Daylight Opening plus(+) 3/4" plus(+) an additional 1/4" for each foot of length. For E2-0801 only, notch the ends of the vertical gasket as shown.
- Insert the gasket into the reglets at each end first; then insert the gasket at the midpoint of the opening.
- Push the gasket into the reglet starting at the ends and work towards the midpoint.

See **Detail 28**.

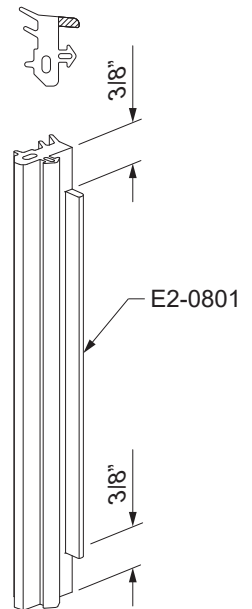

Detail 28
Outside Glazing
Shown, Inside
Glazing Similar

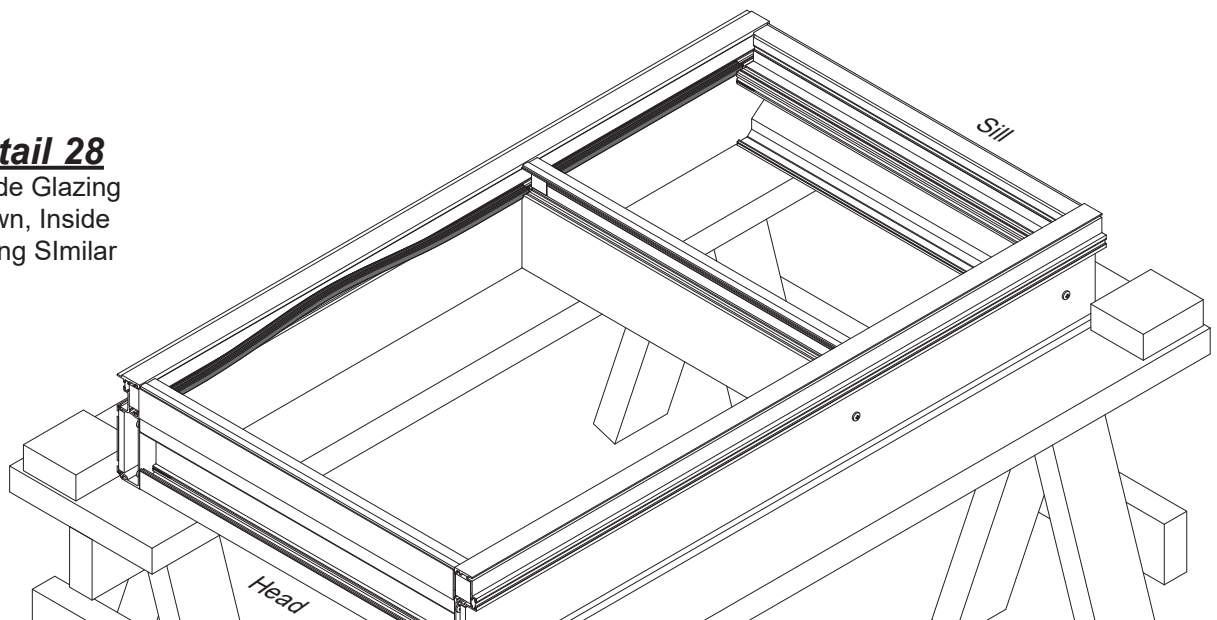

FRAME ASSEMBLY**STEP 17 (Continued)
INSTALL DART GASKETS****Install horizontal glazing gaskets next:**

- Cut horizontal glazing gaskets to Daylight Opening plus(+) 1/4" for each foot of length.
- Apply sealant to each end of the horizontal glazing gasket prior to inserting into the reglet.
- Insert the gasket into the reglet at each end first; then insert the gasket at the midpoint of the opening.
- Push the gasket into the reglet starting at each end and work towards the midpoint.
- Tool the excess sealant at the gasket corners to ensure a watertight seal.

See **Detail 29**.

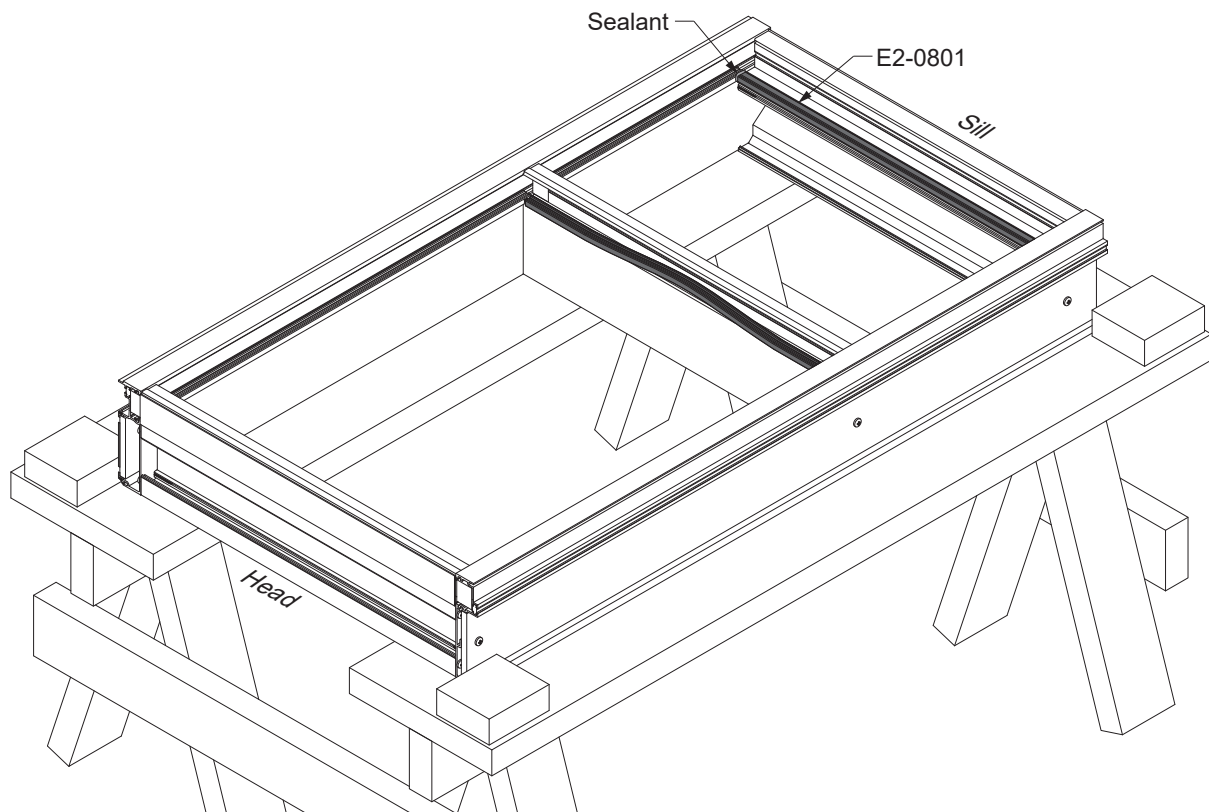

Detail 29
Outside Glazing
Shown, Inside
Glazing Similar

GLAZING

STEP 18
INSTALL SETTING / SIDE BLOCKS

-Apply setting blocks into the glazing pockets for every sill and intermediate horizontal as shown in **Detail 30** at quarter points at every daylight opening. Adhere all setting blocks and E2-0628 side blocks to their respective framing members with sealant.

-Apply side blocks to the shallow pocket.

E2-0133		For Male Mullion
E2-0150		For Sill Members
E2-0628		For Jamb
E2-0178		For Int. Horizontals

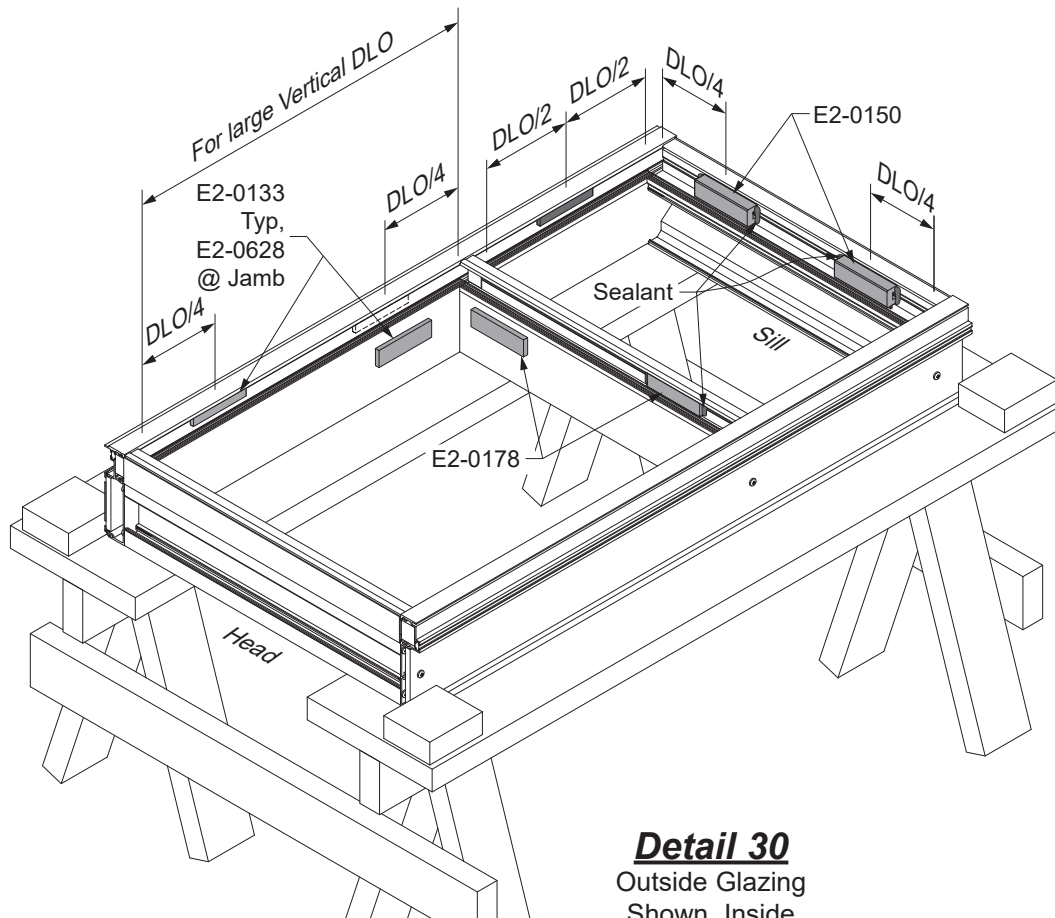

Detail 30
Outside Glazing
Shown, Inside
Glazing Similar

Packing/Shipping Notes:

If packing units horizontally, set units with shallow pocket down. Also on conditions with a double pocket, like a jamb/jamb punched opening or similar corner condition, use a setting block on one jamb (ship this side down.) See **Page 39** for application of “This Side Down” label.

GLAZING

**STEP 19
INSTALL GLASS**

Determine the glass size:

	Width	Height
Standard Glazing	D.L.O. + 7/8"	D.L.O. + 7/8"

-Install the glass lites into the daylight openings. Bring the glass lites into the deep glazing pocket first. Then move the glass lites to their proper positions ensuring a 7/16" glass bite all around and tight against the setting and side blocks.

See **Details 31 & 32**.

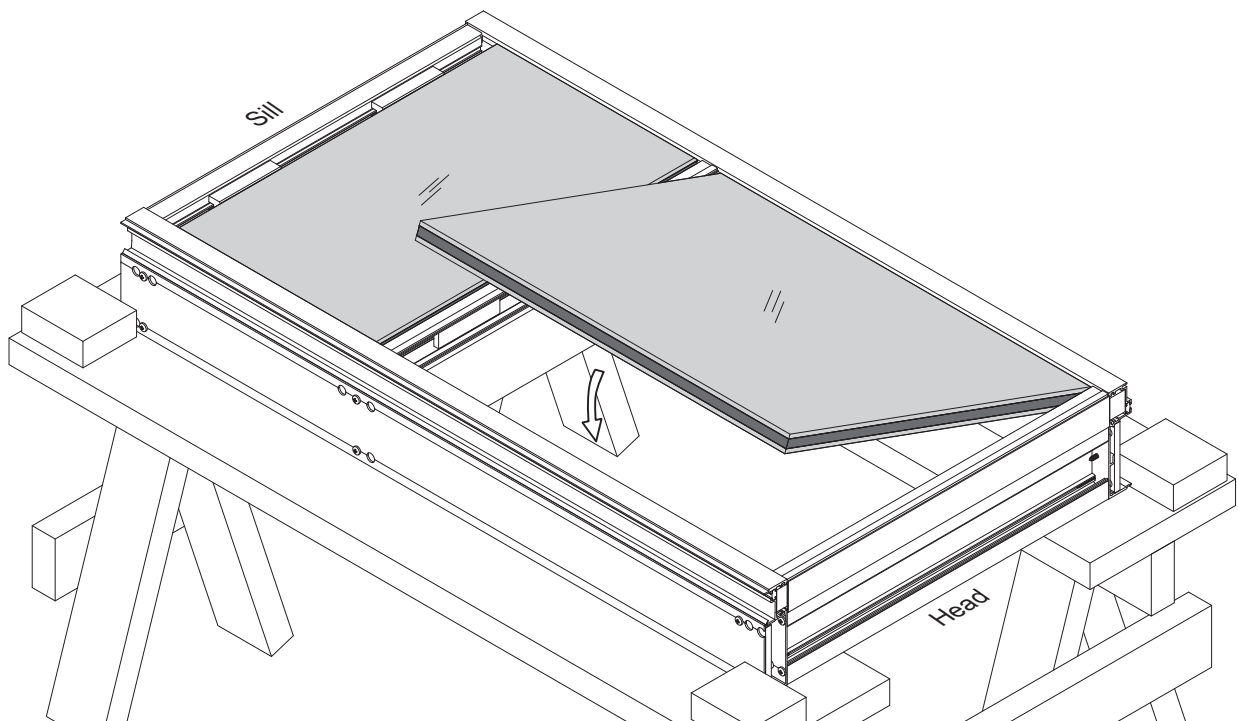

Detail 31

Outside Glazing
Shown, Inside
Glazing Similar

GLAZING

STEP 19 (Continued)
INSTALL GLASS

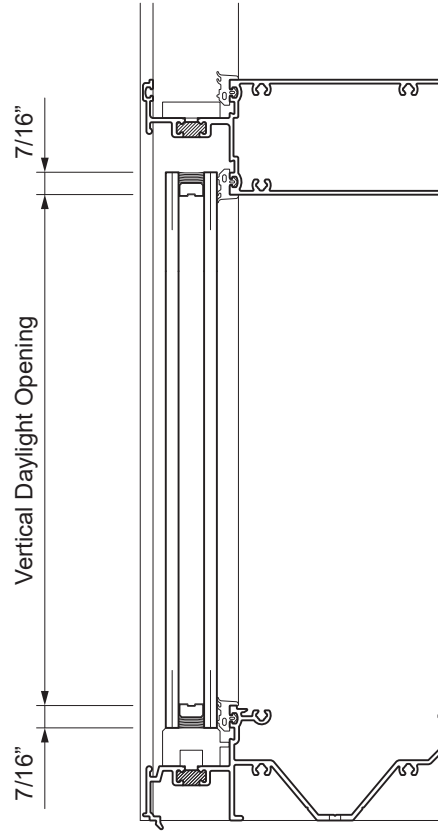

Detail 32
Outside Glazing
Shown, Inside
Glazing Similar

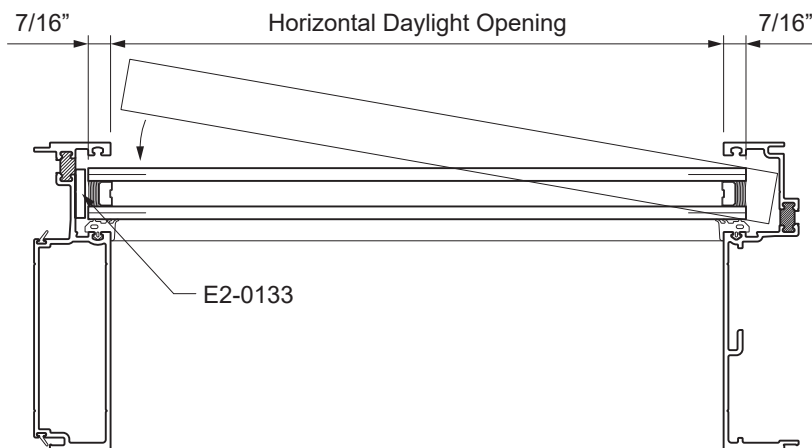

GLAZING

**STEP 20
INSTALL ANTI-WALK BLOCKS**

Anti-walk blocks must be installed in the vertical deep glazing pocket of each lite centered along the daylight opening.

- E2-0546 for all female mullions
- E2-0133 at male mullion

-Flatten the anti-walk block against the surface of the glass and push it into the opening between the glass and the mullion until it is released into the glazing pocket.

-Adhere E2-0068 setting blocks with silicone to the frame at the topside of each lite at each end of the daylight opening. Be sure to set the inside face of the setting block flush with the glass and in the proper orientation as shown in **Detail 33**. This will keep the glass from shifting as the unit is raised for installation. If the glass is oversized, trim the blocks to fit.

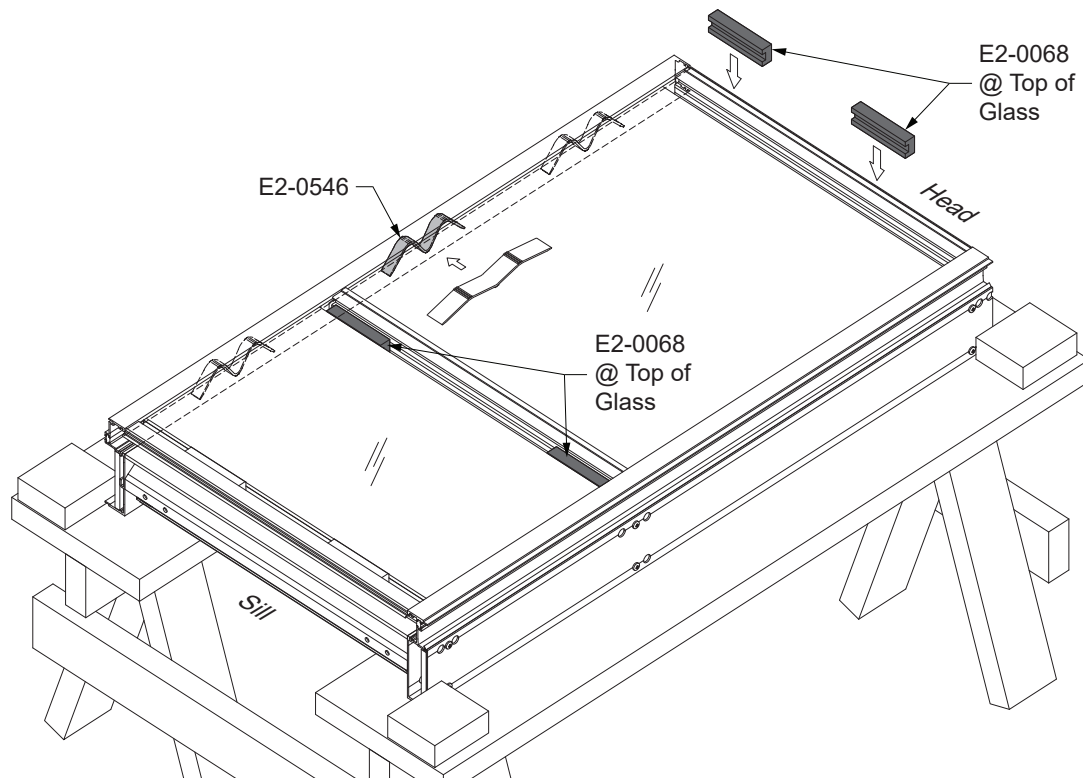

Detail 33
Outside Glazing
Shown, Inside
Glazing Similar

GLAZING

**STEP 21
INSTALL GLASS STOPS (OUTSIDE GLAZING)**

- Apply sealant to the top corners of the D.L.O. where the E9-1715 glass stops will be joined.
- Set the glass stops in place.
- Tool sealant at intersection of the glass stop to the vertical mullion.

See **Detail 34**.

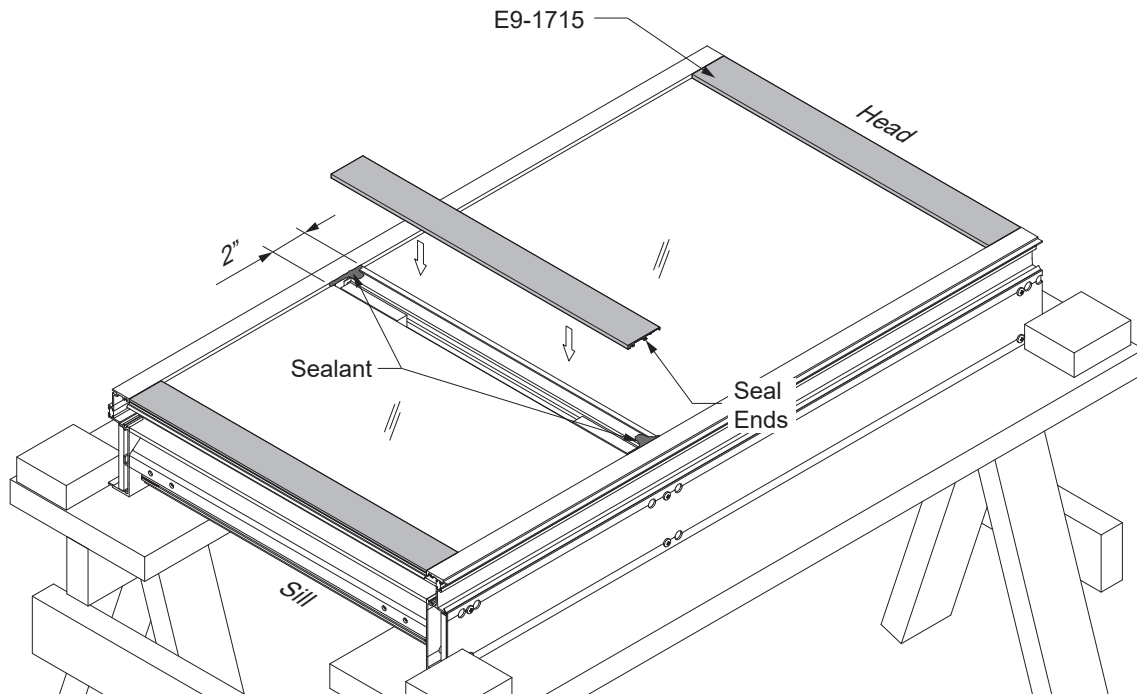

Detail 34

- To secure the intermediate glass stop to the unit, insert the wedge gasket (cut to D.L.O.) into the exterior of the glazing pocket, leaving the ends of the gasket out until the vertical gaskets are inserted.

See **Detail 35**.

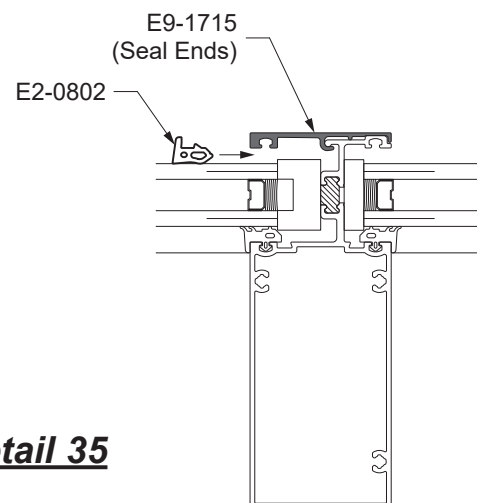

Detail 35

GLAZING**STEP 22
INSTALL GLASS STOPS (INSIDE GLAZING)**

- Apply sealant to the top corners of the mullions where the E9-7852 glass stops will be joined against the mullion.
- Set the glass stops in place at the top of each daylight opening and secure the stop in place by drilling #12 tap holes (0.189" dia.) and using PC-1210 fasteners.
- Tool sealant at intersection of the glass stop to the vertical mullion.

See **Detail 36**.

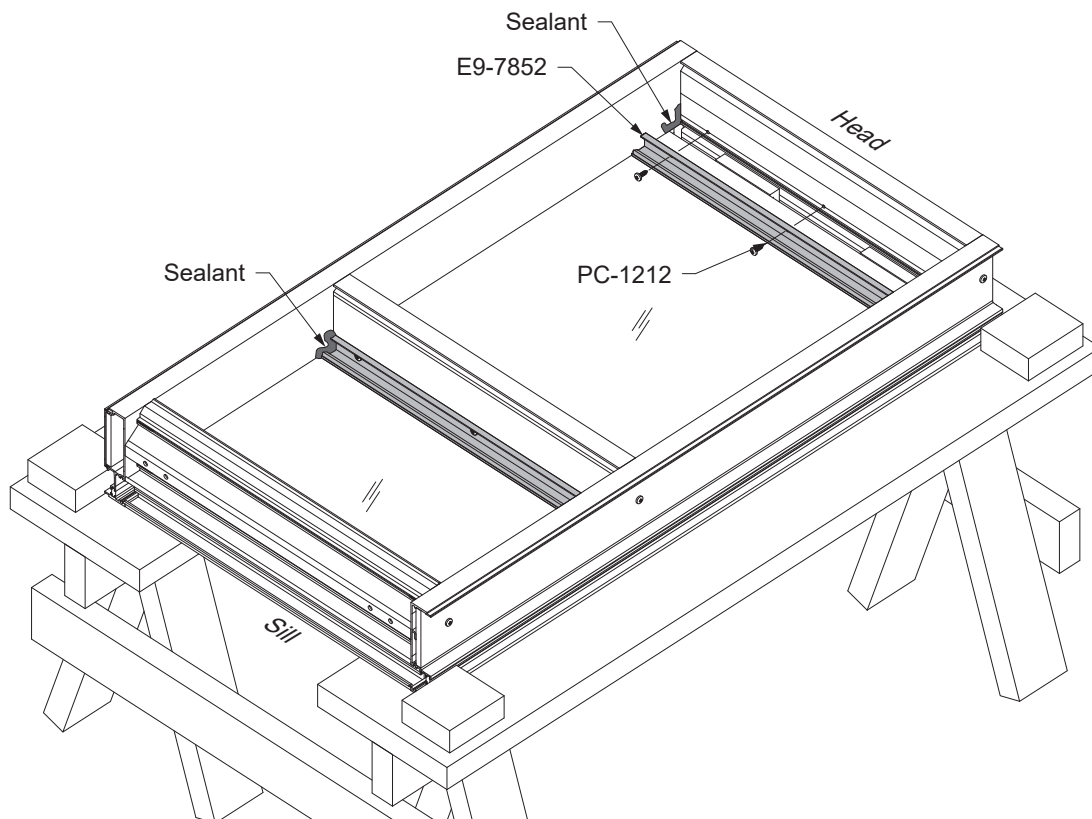

Detail 36

Note: Interior glass stops can be used on outside glazed units with inside reglazing option.

GLAZING

STEP 23
SEAL GLASS TO PVC FILLERS AT JAMBS

-In order to ensure the glass will not shift during transit, apply 6” of silicone sealant between the glass and the pvc fillers at the jamb mullions. Do not let the sealant cure before inserting the wedge gasket.
-Also seal the glass to the framing on the shallow pocket female mullion.

See **Detail 37**.

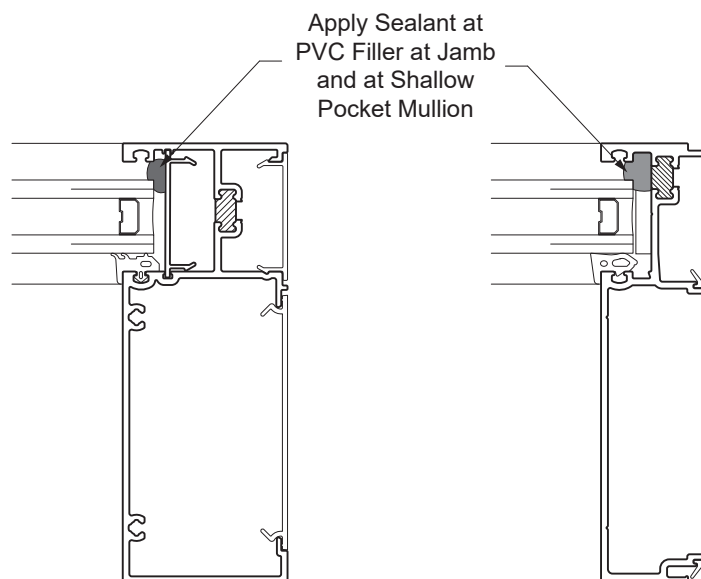

Detail 37

GLAZING

**STEP 24
INSTALL WEDGE GASKETS**

-Cut vertical E2-0808 wedge gasket to Daylight Opening plus(+) 3/4", plus(+) an additional 1/4" every foot of length. Notch the ends of the gasket by 3/8" as shown in **Detail 38**.

-Insert the wedge gasket into the glazing pocket at end points first, then work towards the midpoint.

See **Detail 39**.

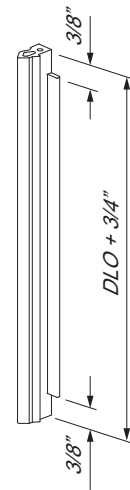

Detail 38

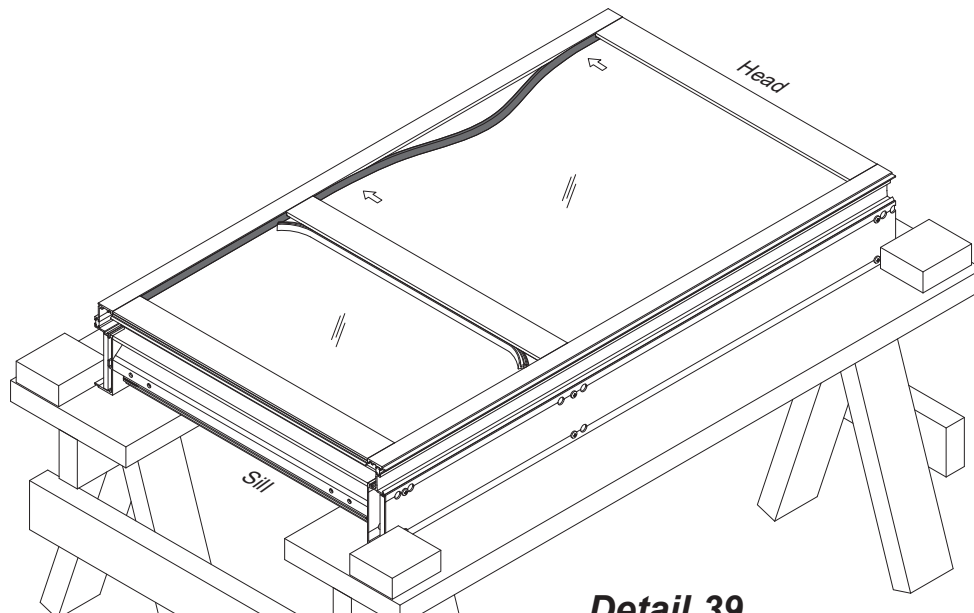

Detail 39
Outside Glazing
Shown, Inside
Glazing Similar

GLAZING

**STEP 24 (Continued)
INSTALL WEDGE GASKETS**

- Cut E2-0808 head and sill gaskets to Daylight Opening.
- Apply silicone to each end of the gasket and also to the ends of the intermediate horizontal gaskets already inserted.
- Next, insert the horizontal gasket into the glazing pocket, centered on the Daylight Opening at each end first; then insert the gasket at the midpoint of the opening and work towards each end. Ensure the horizontal and vertical gaskets are sealed together. Tool excess silicone smooth.
- Affix E4-0008 (This Side Down) Static label to the glass, orienting the arrows to the sill and the mullion with the shallow pocket or the jamb with the setting blocks.

See **Detail 40**.

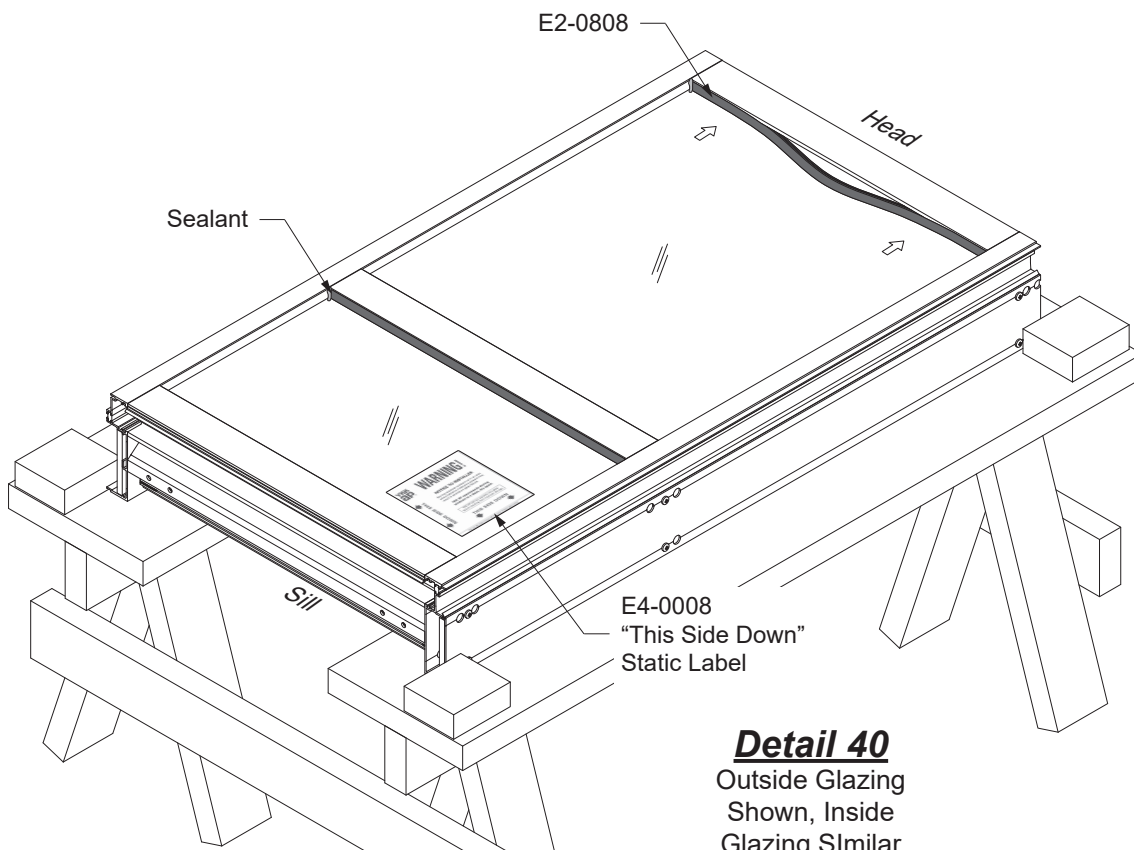

Detail 40
Outside Glazing
Shown, Inside
Glazing Similar

FRAME INSTALLATION

**STEP 25
INSTALL SILL FLASHING END DAMS**

-Bend the end dam tab left or right 90 degrees in order to “hand” the end dam for the left or right end of the flashing.

See **Detail 41**.

- Clean all joint surfaces using cleaner approved by sealant manufacturer.
- Apply sealant to the end of the sill flashing as shown in **Detail 42**.
- Slide the tab into the top portion of the sill flashing.
- Tap the tab into place with a small tool until the end dam is snug against the end of the flashing.
- Fasten the end dam to the sill flashing with three UA-1212 screws, starting at the back, followed by the front as shown in **Detail 42**.
- Tool sealant along the joint between the end dam and the sill flashing as shown in **Detail 43**.

E1-1141 for YWW 50 TU
E1-1142 for YWW 60 TU

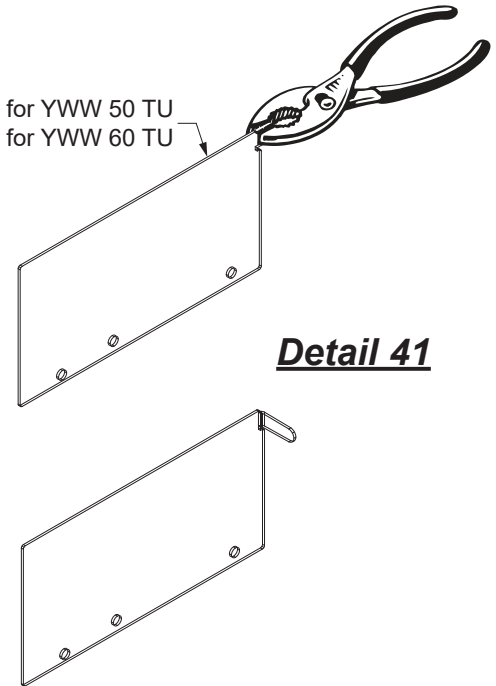

Detail 41

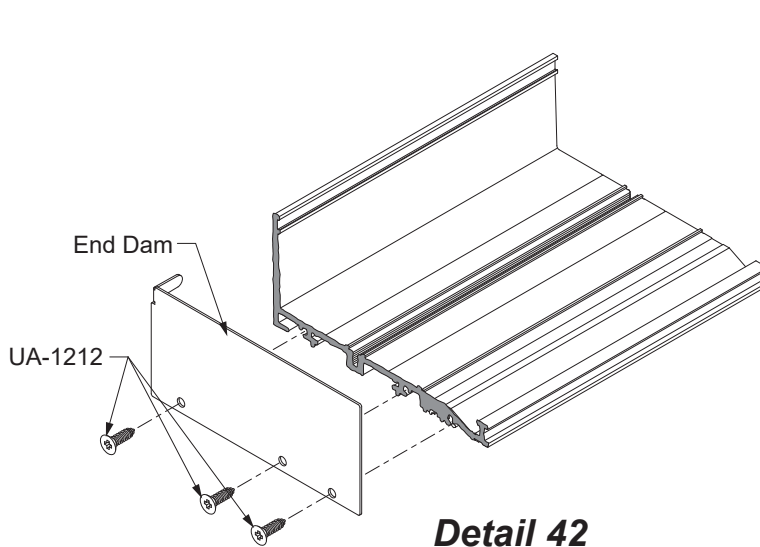

Detail 42

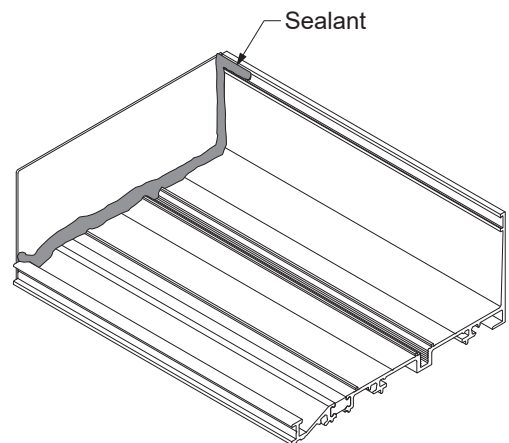

Detail 43

FRAME INSTALLATION

**STEP 25A
INSTALL SILL FLASHING END DAMS FOR SLAB
EDGE COVER**

- Sill flashings with slab edge covers will require an aluminum plate adaptor E9-8222 to be attached prior to field installation.
- Insert (2) E2-0065 weathering gaskets cut to the length of the reglets on the adaptor.
- Slide the slab edge adaptor onto the sill flashing.

See **Detail 44**.

- Installation of the E1-1196 end dam is the same as illustrated in the previous page, except that the end of the installed slab edge adaptor will also require sealant.
- Fasten an E1-1196 end cap onto the slab edge assembly using an additional UA-1212 screw.

See **Detail 45**.

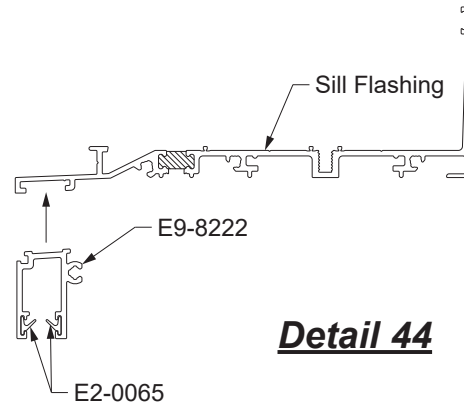

Detail 44

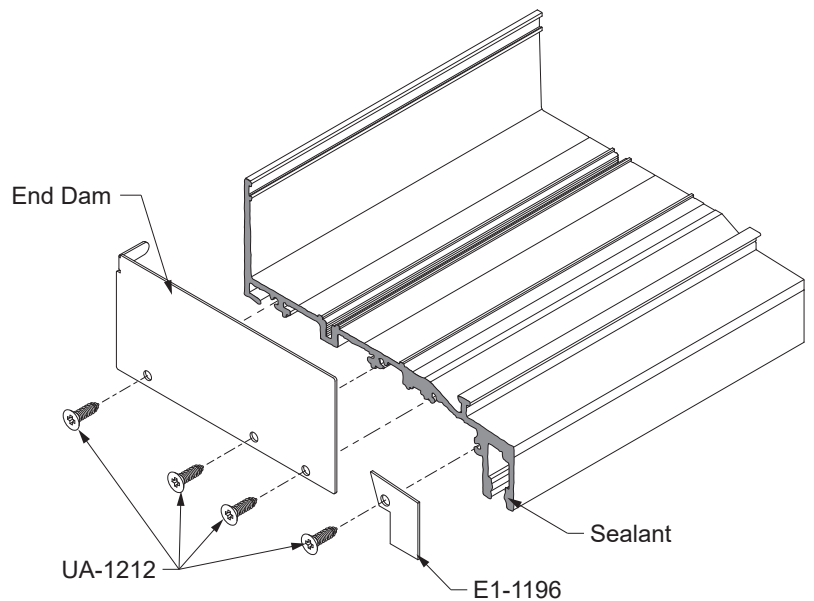

Detail 45

FRAME INSTALLATION

**STEP 26
INSTALL BE9-2729 SILL FLASHING**

- Prior to installing the sill flashing, slide in E1-1191 strap anchors (2 per DLO) if they are being used.
- Install the sill flashing with a minimum of 3/8" shim space underneath. Sill flashing must be installed level.
- Anchor the sill flashing to the structure a maximum of 4" from each end and then 18" to 24" on center, per P.E. calculations, or per FPA drawings.
- Apply and tool sealant to cover the heads of all anchors and screws.

**STEP 27
INSTALL SILL FLASHING SPLICE SLEEVE**

- Remove the nub with a chisel or pliers on both sides of the splice joint 1-1/2" as shown in **Detail 46**.
- After the sill flashing has been shimmed and anchored to the building structure, insert a small backer rod under the sill flashing as shown in **Detail 47**.
- Position the Silicone Splice Sleeve against the back wall below the groove.
- Bend the Silicone Splice Sleeve into the front on the channel as shown. Mark and cut the sleeve at this position.
- Clean Sill Flashing and Silicone Splice Sleeve with isopropyl alcohol at the splice location.
- Seal the flashing at the splice location as shown in **Detail 47**, before positioning the flashing. Set the Silicone Splice Sleeve into the sealant.
- Tool sealant tight as shown in **Detail 47**, squeezing the sheet flat with a seam roller.

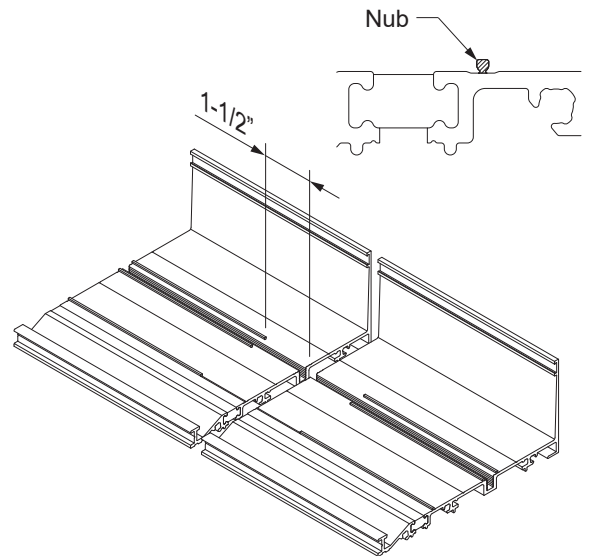

Detail 46

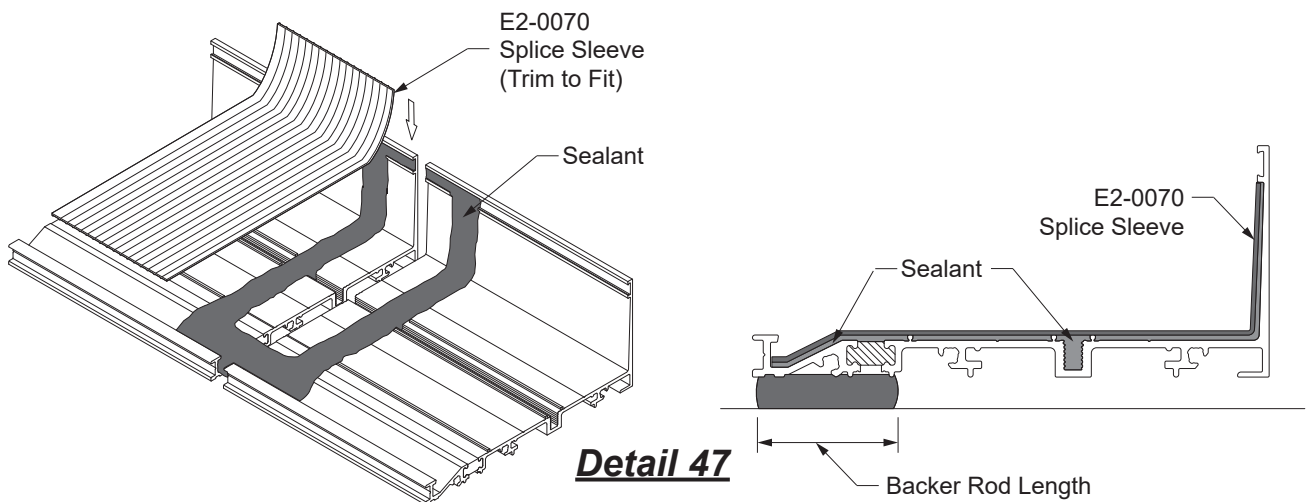

Detail 47

FRAME INSTALLATION

STEP 27 (Continued)
INSTALL SILL FLASHING SPLICE SLEEVE

-Thoroughly seal the small joint directly in front of the Silicone Splice Sleeve as shown in **Detail 48**.

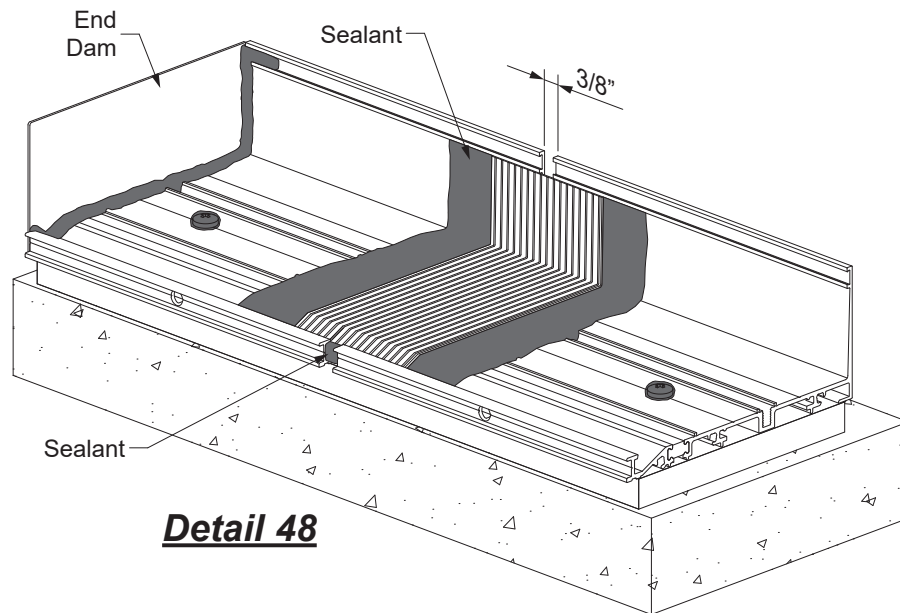

FRAME INSTALLATION

**STEP 28
SLAB EDGE COVER INSTALLATION**

Slab edge covers are installed from the head of the lowest elevation on upward. The head receptors are installed first, then slab edge plates, then the BE9-2735 sill flashings with the E9-8222 slab edge adaptors.

**STEP 28A
INSTALL HEAD RECEPTOR END DAMS & WEATHERING GASKETS**

- Clean all joint surfaces using cleaner approved by sealant manufacturer.
- Apply sealant to the end of the head receptor as shown in **Detail 49**.
- Fasten the end dam to the head receptor with two UA-1212 screws, starting at the back, followed by the front.
- Tool sealant along the joint between the end dam and the head receptor as shown in **Detail 50**.
- Tape down the top corners to hold the end cap in place until the sealant cures.

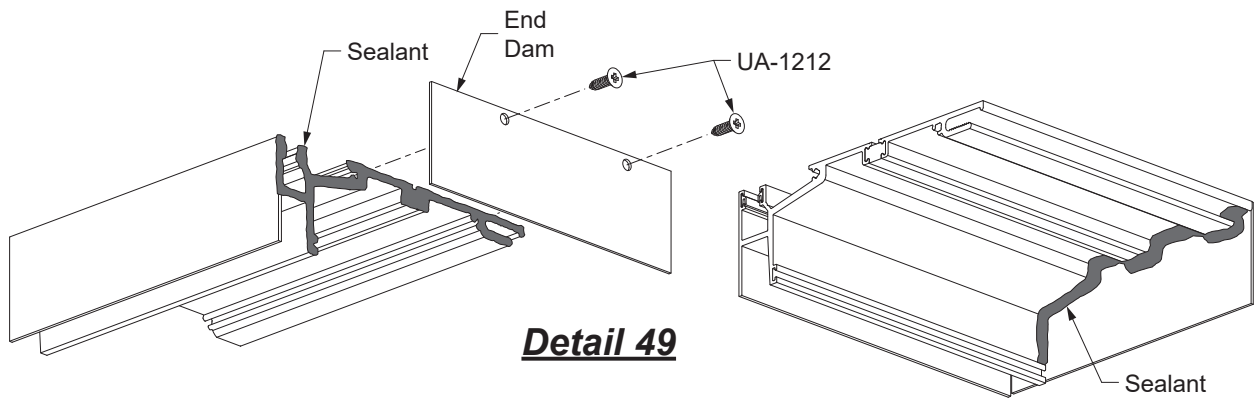

- Cut the E2-0051 airtight gasket to head receptor length plus 3/16" at each end for the splice joint, and insert it into its reglet for both the receptor and snap cover as shown in **Details 51 & 51A**.
- Cut the E2-0065 slab edge weathering gaskets to head receptor length. Insert the gaskets into the slab edge reglets in the orientation as shown in **Details 51A**.

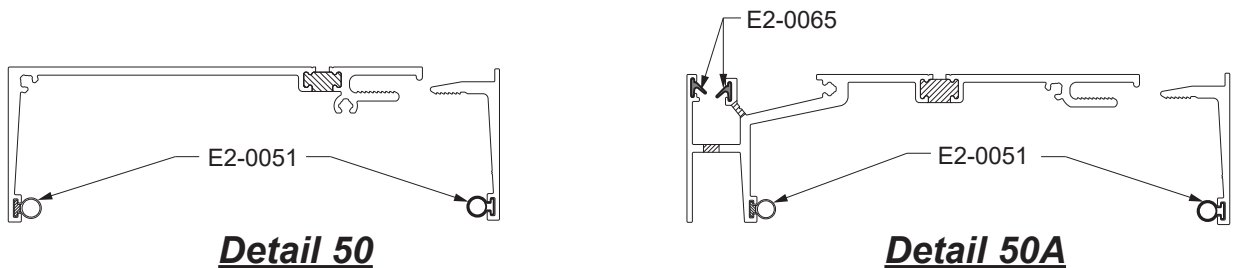

FRAME INSTALLATION

STEP 28B INSTALL HEAD RECEPTOR

- Starting at the smallest opening height, install the head receptor with the appropriate shim to ensure the dimensions from the approved shop drawings. Head receptor must be installed level.
- Anchor the head receptor to the structure according to approved shop drawings and or P.E. calculations.
- Apply and tool sealant to the heads of all fasteners as shown in **Detail 51**.

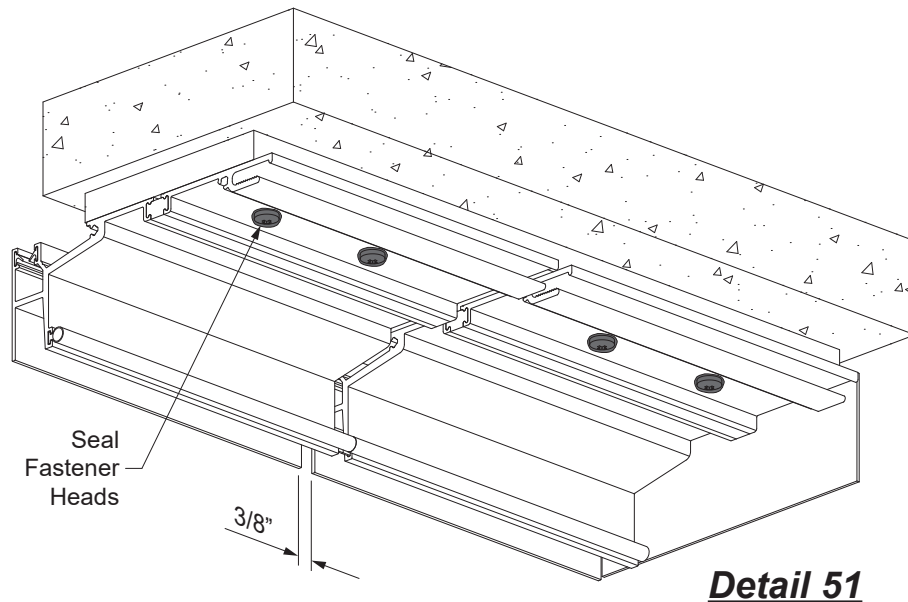

FRAME INSTALLATION

**STEP 28B (Continued)
INSTALL HEAD RECEPTOR**

-Prior to installing the Splice Sleeve, clean head receptor and Splice Sleeve with isopropyl alcohol at the splice location.

-Refer to the splice chart at the right for proper splice selection per head receptor used.

System	Head Receptor	Splice
YWW 50 TU	BE9-7635	E2-0070
YWW 50 TU	BY7-8426	E2-0070
YWW 50 TU	BE9-2819	E1-2813
YWW 60 TU	BE9-7736	E2-0070
YWW 60 TU	BE9-7229	E1-9824

-Position the Splice Sleeve against the front wall inside the head receptor, set in sealant centered on the splice joint as shown in **Detail 52**. For E2-0070 sheet, trim as necessary to fit.

-Tool the sealant. For E2-0070 sheet, use a seam roller to press the sheet tight against the receptor.

-Seal the ends of the E2-0051 gasket together at the splice.

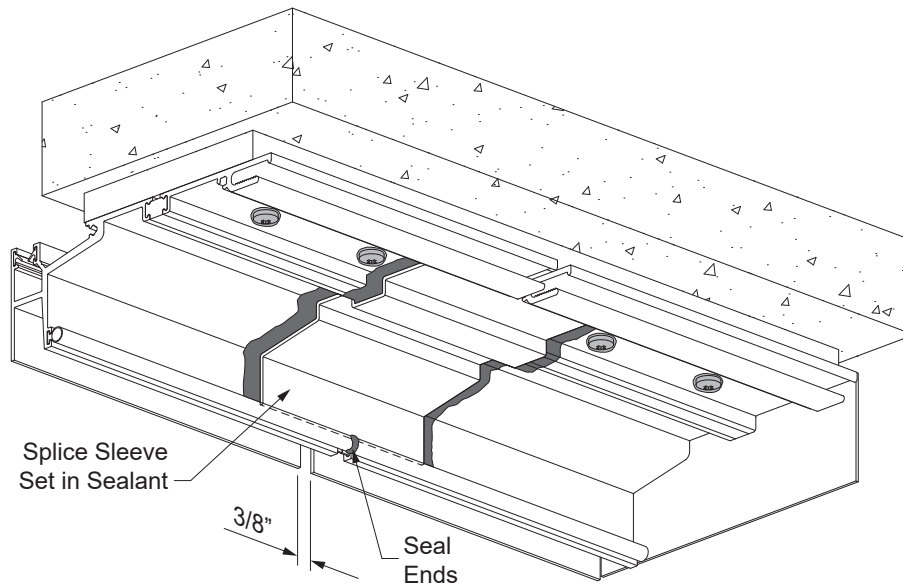

Detail 52

FRAME INSTALLATION

STEP 28B (Continued)
INSTALL HEAD RECEPTOR SPLICE SLEEVE

-At the slab edge receptacle of the head receptor, position an E1-9961 splice sleeve centered on the splice joint. Set the splice sleeve in sealant, similar to the procedure previously outlined for the underside of the head receptor.

See **Detail 54**.

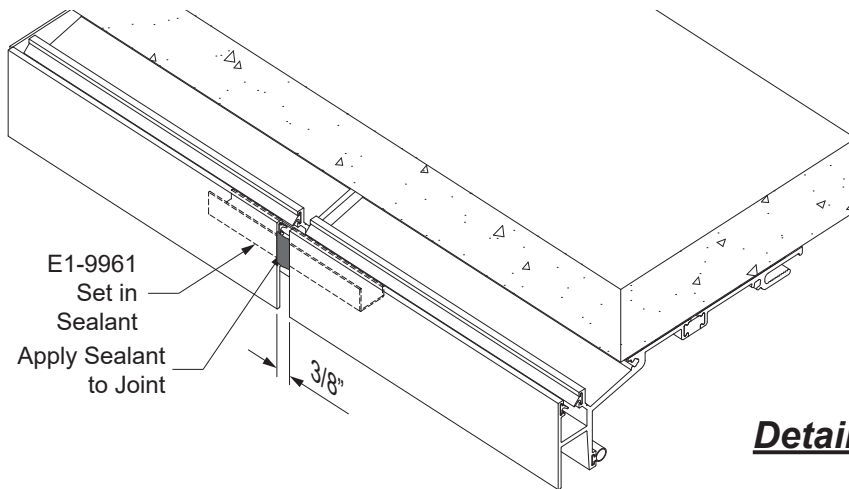

Detail 54

FRAME INSTALLATION

STEP 28B (Continued)
INSTALL HEAD RECEPTOR GASKETS

- Install E2-0054 setting blocks at 1/4 points of the aluminum plate.
- Install a weep baffle, E2-0099, over every weep hole location.
- Do not install the snap cover yet.

See **Detail 54**.

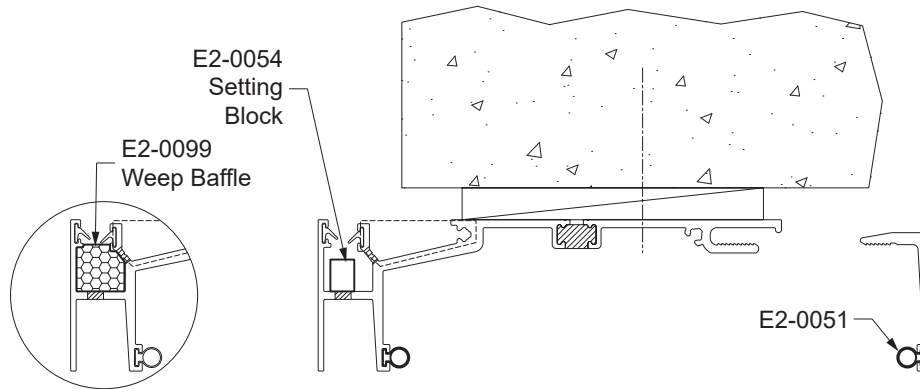

Detail 54

STEP 28C
ASSEMBLE SLAB EDGE COVER PLATES

- Clean the ends of the slab edge cover and attachment areas of end caps using a cleaner approved by sealant manufacturer.
- Apply and tool sealant to each end of the slab edge cover prior to attaching the end caps.
- Attach end caps to each end of the slab edge cover using (2) UA-1212 fasteners.
- Tool and wipe away any excess sealant at the joints.

See **Detail 55**.

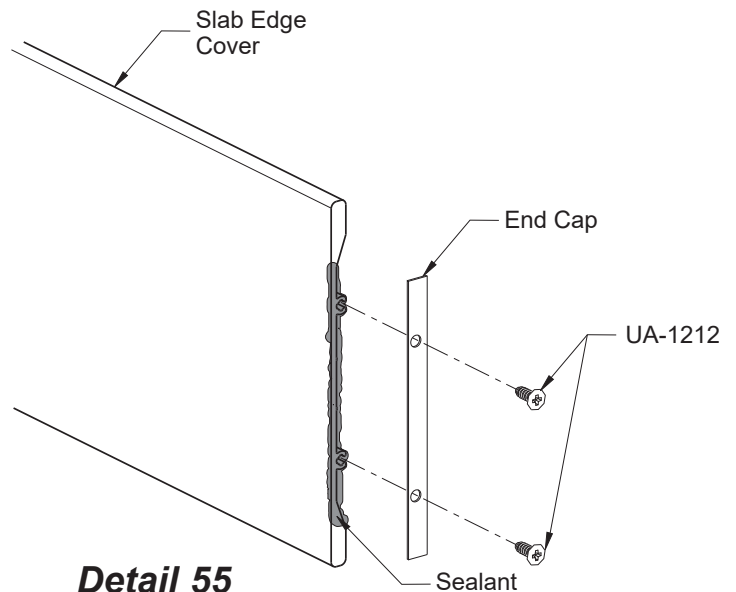

Detail 55

FRAME INSTALLATION

**STEP 28D
INSTALL SLAB EDGE COVER FASCIA**

- Slide the slab edge cover plate into the head receptor receptacle, seating it on top of the setting blocks.
- Be sure to leave a 3/8" joint between the plates for runs longer than 24'-0".

See **Detail 56**.

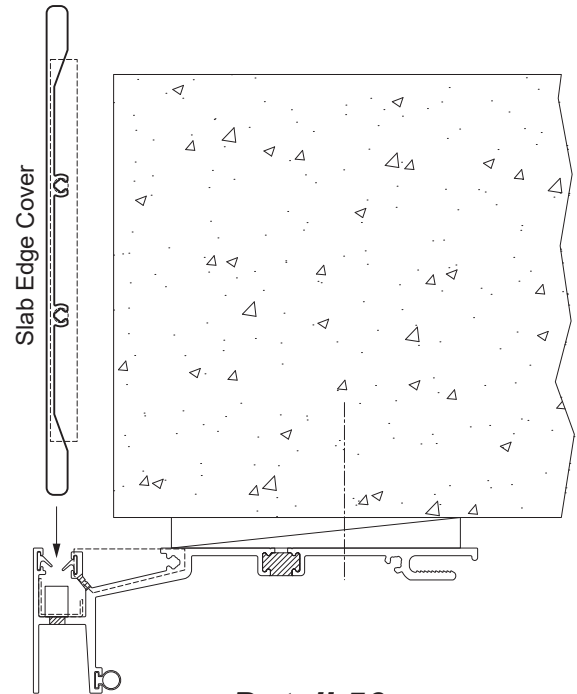

Detail 56

**STEP 28E
INSTALL SILL FLASHING SPLICE SLEEVE FOR
SLAB EDGE COVER**

Before installing the sill flashing, install an E1-9959 splice sleeve at the underside of the sill flashing and slab edge adaptor.

- Apply bond breaker tape down the middle of the splice sleeve and sealant to one side of the splice sleeve as shown in **Detail 57**.
- Adhere the sealed half of the splice sleeve to the underside of the sill flashing.

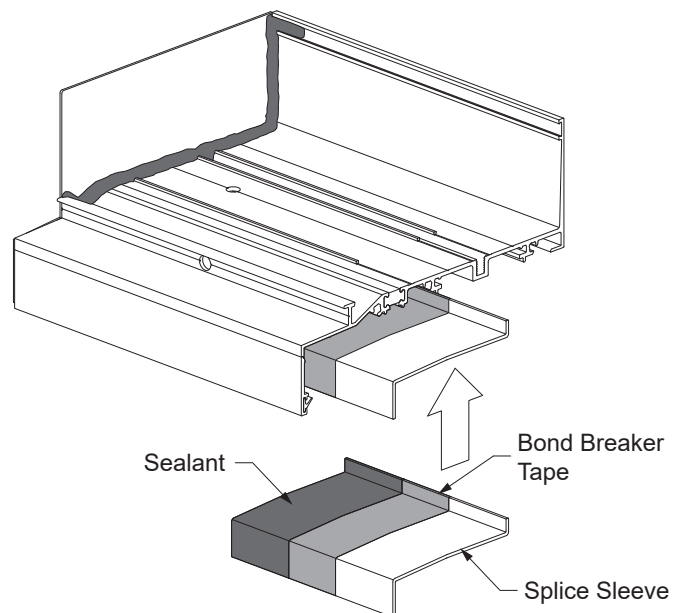

Detail 57

FRAME INSTALLATION

STEP 28E (Continued)

INSTALL SILL FLASHING SPLICE SLEEVE AT SLAB EDGE

- Install the sill flashing assembly onto the substrate, engaging the slab edge cover plates below and sealing all anchor fastener heads.
- Install the next slab edge sill flashing assembly onto the splice sleeve as shown in **Detail 58**. Be sure to leave a 3/8" joint between the sill flashing assemblies.

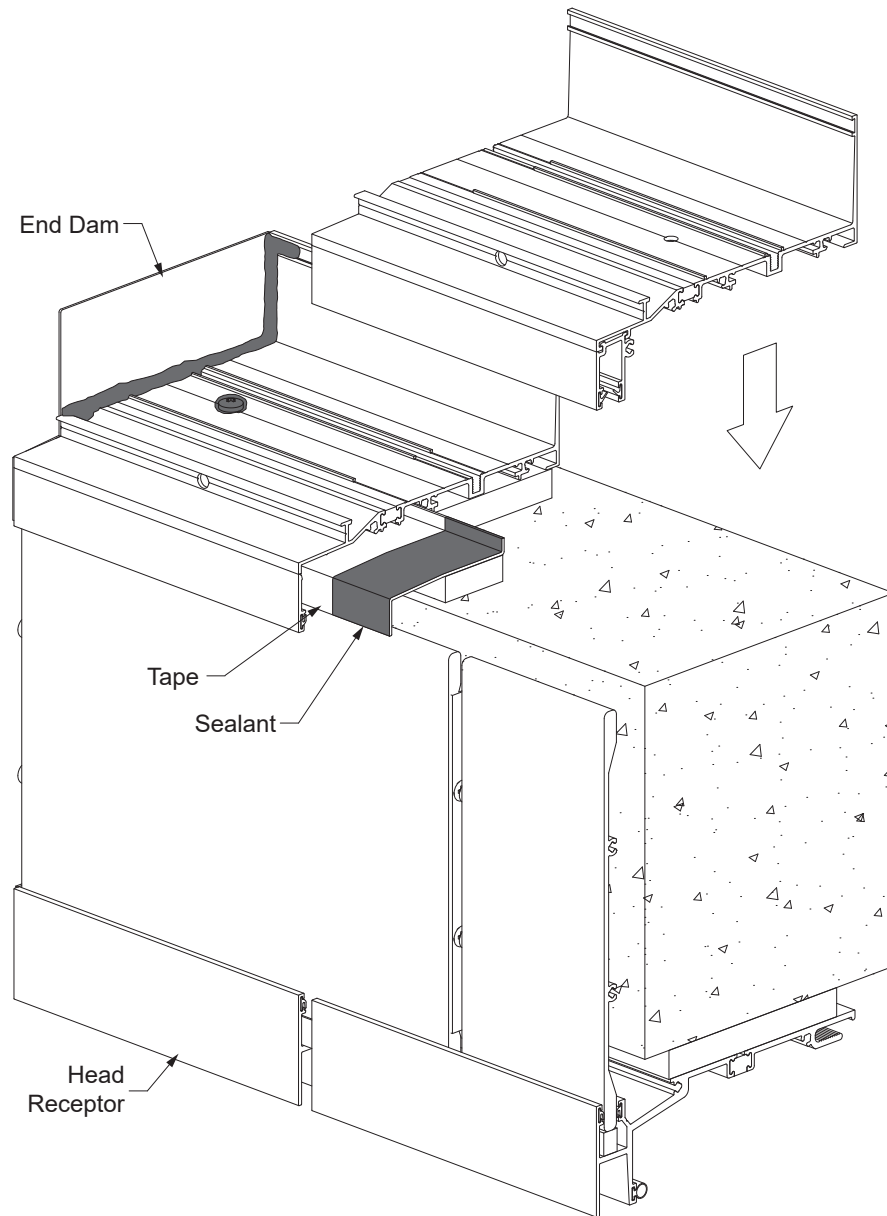

Detail 58

FRAME INSTALLATION

STEP 28E (Continued)

INSTALL SILL FLASHING SPLICE SLEEVE AT SLAB EDGE

-Installation of the E2-0070 splice sleeve is the same as previously outlined in **Step 28**, except to apply sealant to the joint at the slab edge cover plate, adaptor, and head receptor as shown in **Detail 59**.

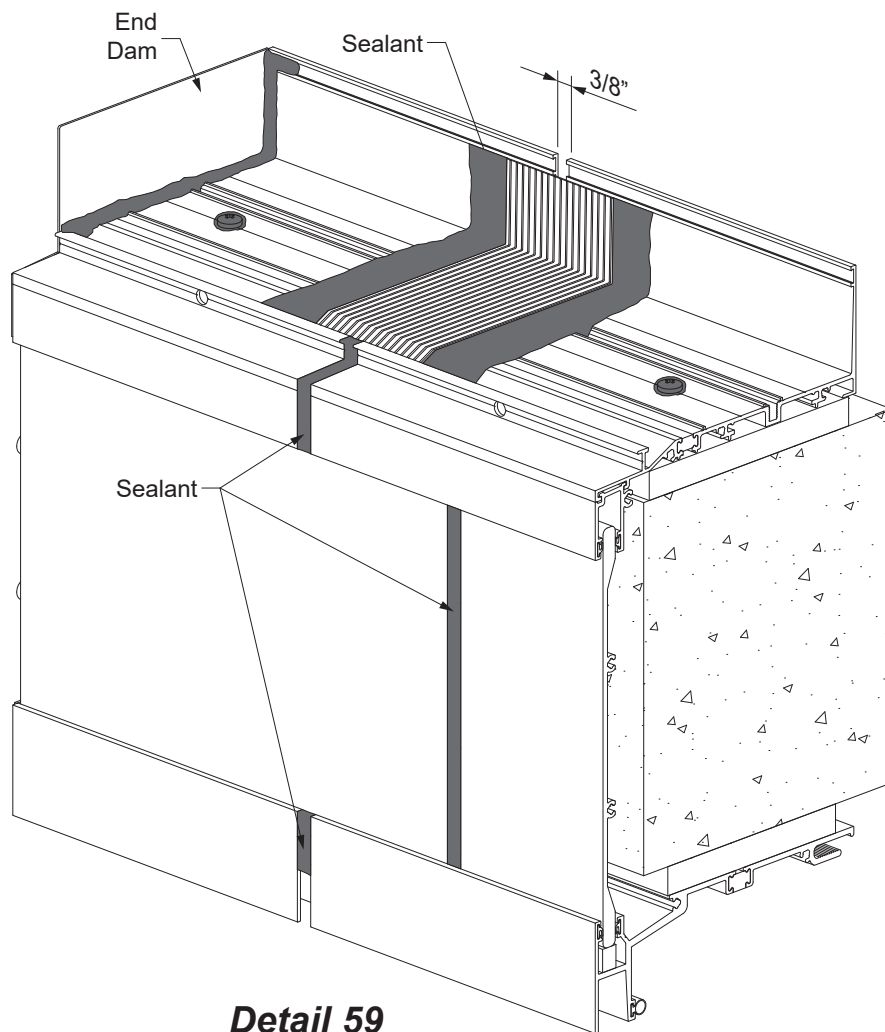

Detail 59

FRAME INSTALLATION

STEP 29

INSTALL BE9-2274 / BE9-2756 SILL FLASHING AT CORNERS

- Cut two 12" long pieces of sill flashing and miter(45° for 90° corners).
- Align the two pieces at the corner condition with the mitered ends pushed together tight and anchor the sill flashing as indicated on the approved shop drawings and or P.E. calculations.
- Apply and tool sealant to the mitered joint and anchor heads.

See **Detail 60**.

-Continue installing the rest of the sill flashing providing a 3/8" expansion joint at splices as shown in **Step 26 & 27 on Page 42 & 43**.

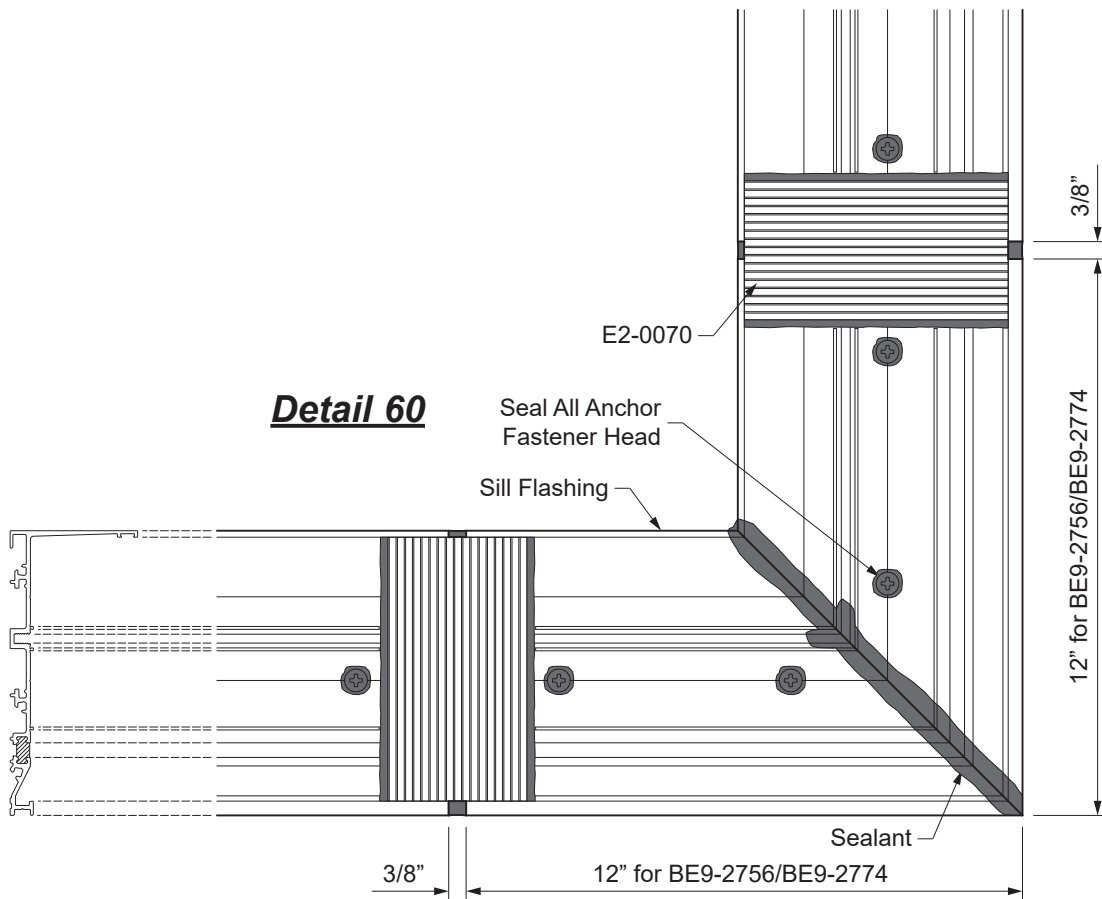

FRAME INSTALLATION

STEP 29A

INSTALL BE9-2775 / BE9-2757 SILL FLASHING AT CORNERS *

- Cut two 13-3/16" long pieces of sill flashing and E9-8222 slab edge cover adaptor, and miter (45° for 90° corners). The head receptor that is to be installed below will also receive the same miter cut fabrication.
- Install the head receptor using similar procedure as previously described for the sill flashing.
- Miter cut the slab edge cover plates 45° for 90° corners, such that upon installation, they leave a 1/2" gap at the corner.
- Fasten end caps onto the edge of the slab edge cover plates.
- Install the slab edge plates onto the setting blocks of the head receptor below.
- Align the two pieces of the sill flashing at the corner condition with the mitered ends pushed together tight and anchor the sill flashing as indicated on the approved shop drawings and or P.E. calculations.
- Apply and tool sealant to the mitered joint and anchor heads.

See **Detail 61**.

- Continue installing the rest of the sill flashing providing a 3/8" expansion joint at splices as shown in **Step 28 Pages 44 to 51**.

* **Note:** Similar technique required for head receptor.

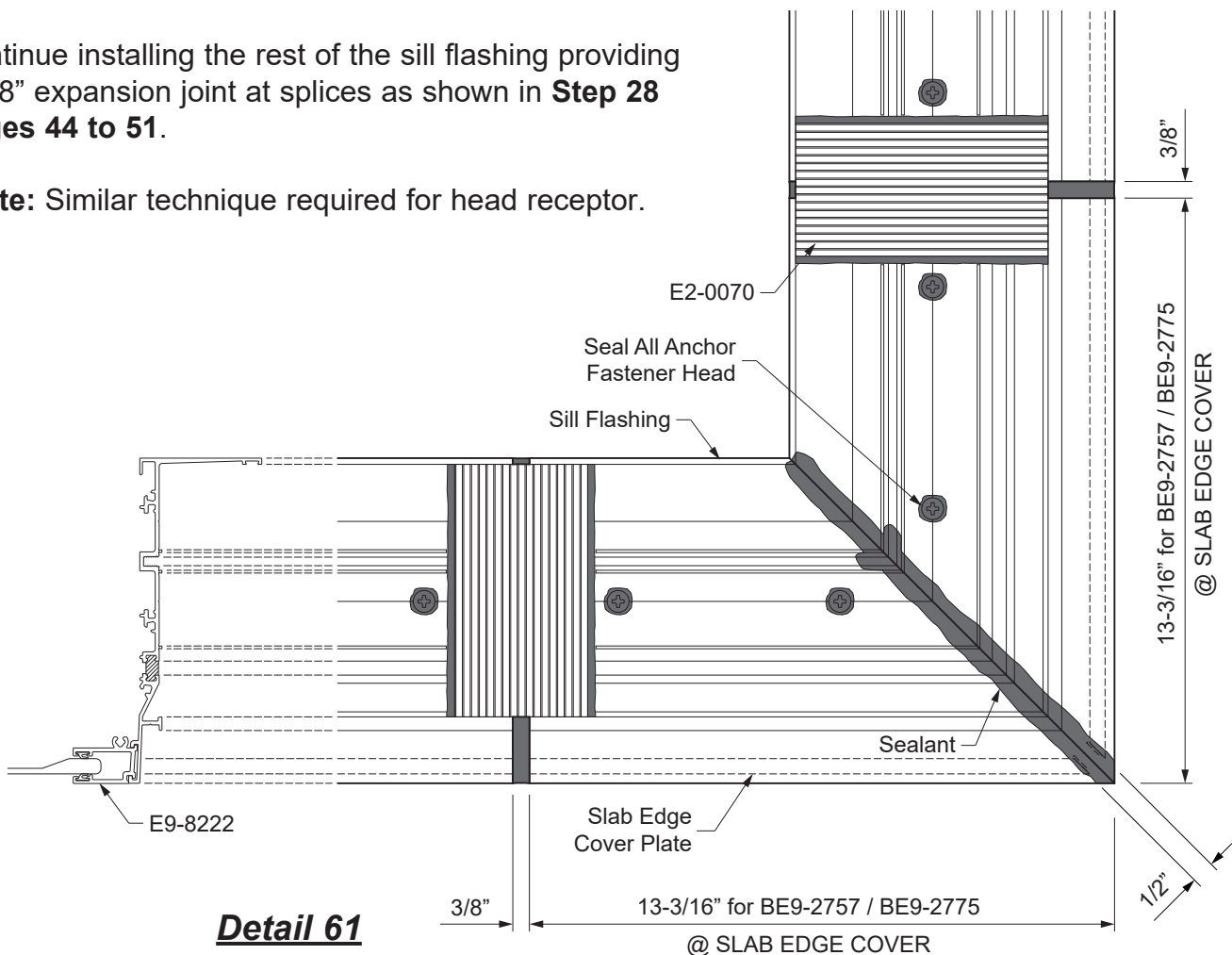

Detail 61

FRAME INSTALLATION**STEP 30
SILL PREPARATION**

At every splice condition, apply bond breaker tape to the back of the sill member before the joint is sealed between the sill and sill flashing.

See **Detail 62**.

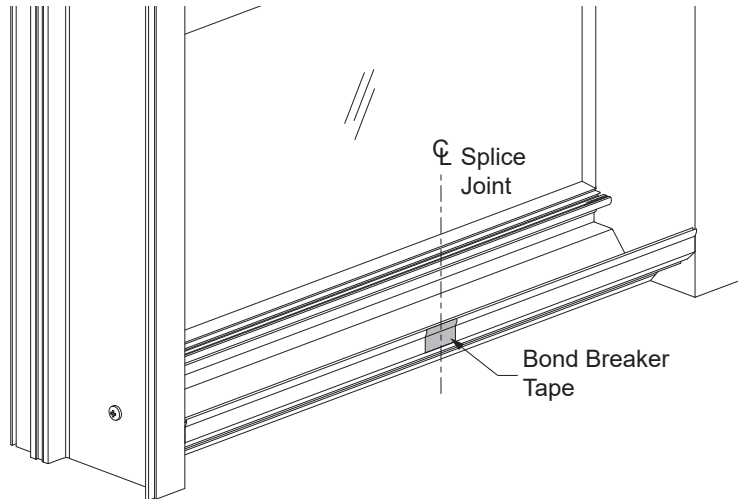

Detail 62

FRAME INSTALLATION

**STEP 31
INSTALL FRAMES**

-The female mullion half of the second unit engages into the male mullion half of the previously installed unit, from the side.

-For frames that utilize the E1-1190 channel shaped head anchor, secure the anchor to the head using masking tape as shown in **Detail 63** prior to installation into the frame opening.

-Set the frame into place. See **Detail 64** for shim space at head.

-Taking care to ensure the framing unit is plumb, level, square, and true, anchor the framing unit to the substrate, first at the head using fasteners as specified by engineering calculations.

See **Detail 64**.

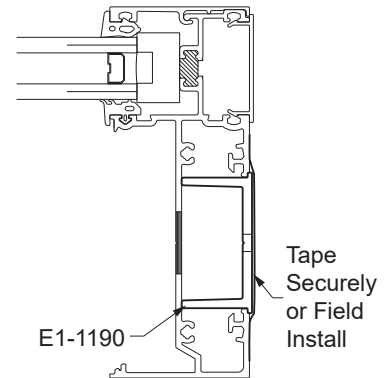

Detail 63

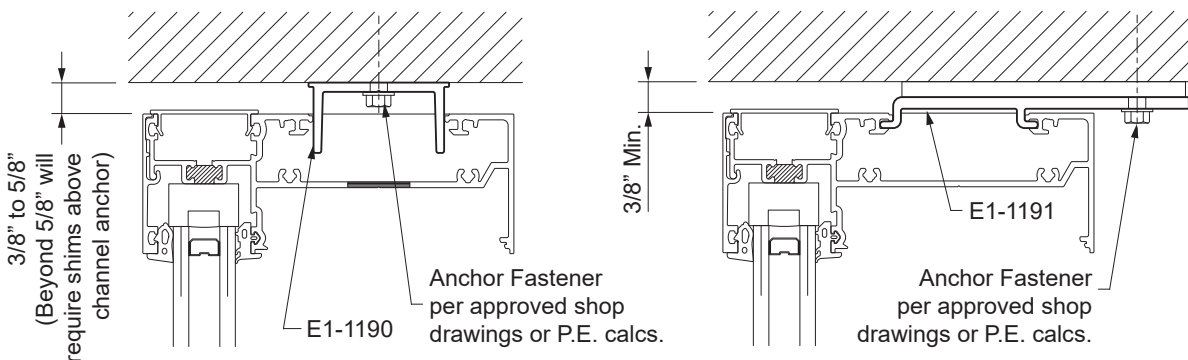

Detail 64

FRAME INSTALLATION

**STEP 31 (Continued)
INSTALL FRAMES**

-For end reactions greater than 500 lbs. per mullion, fasten the sill to the sill flashing using two (2) PM-2508-SS screws, one at 3" from each end of the sill.

See **Detail 65**.

-Then anchor the jamb strap anchors to the substrate, if applicable.

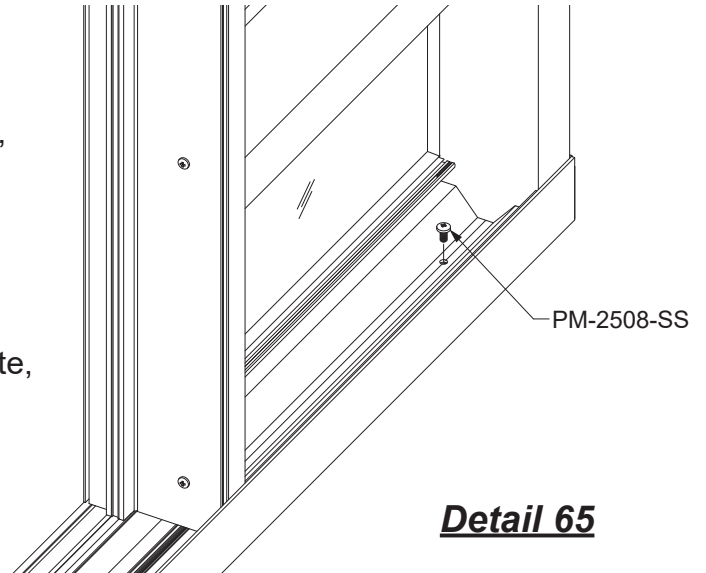

Detail 65

**INSTALL FRAMES WITH
HEAD RECEPTOR**

-Set the frame into place, taking care to ensure the unit is plumb, level, square, and true.

-Snap on the receptor snap cover with the E2-0051 airtight gasket onto the head receptor.

See **Detail 66**.

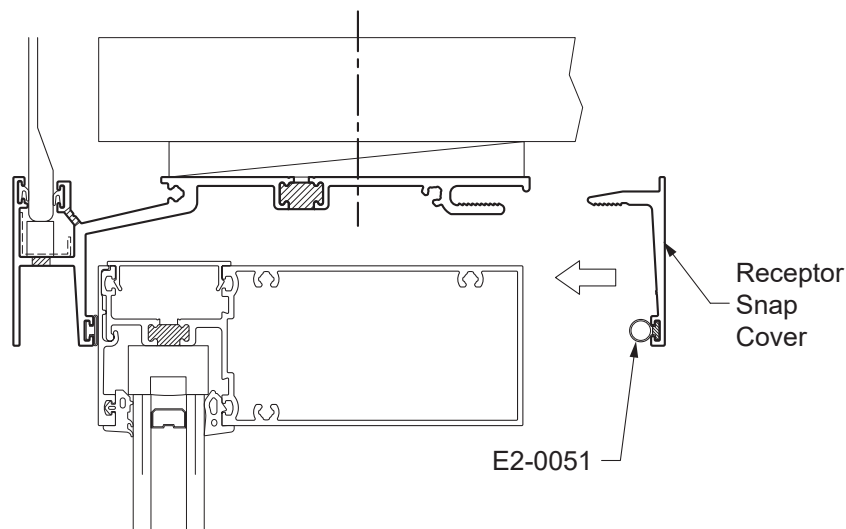

Detail 66

FRAME INSTALLATION

STEP 31 (Continued)
INSTALL FRAMES

Note: If sill has not fully engaged into the sill flashing, tap down with a block of wood to ensure proper engagement prior to sealing (after mullion has been properly placed.)

- Apply sealant to the back of the sill member (the length of the sill) of the installed unit at the sill flashing as shown in **Detail 67**.
- Just prior to installing the next unit, apply sealant to the interior reglet of the female mullion where it will interface with the male mullion of the installed unit (from bottom of mullion and 6" up.) Also, apply 6" of sealant to the sill flashing centered on the mullion centerline as shown in **Detail 68**.

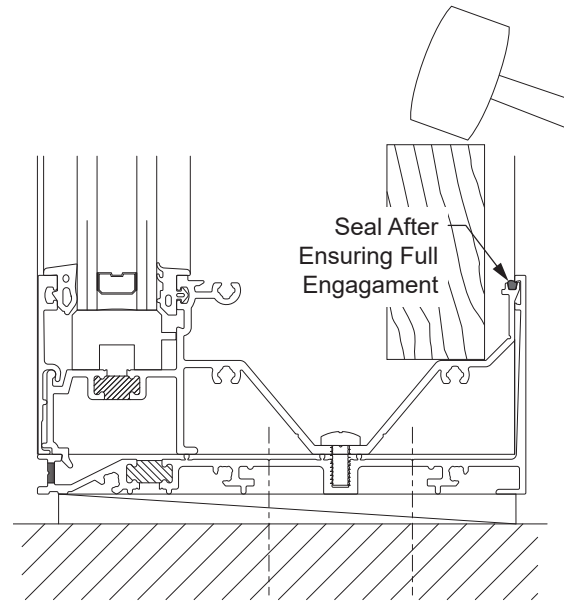

Detail 67

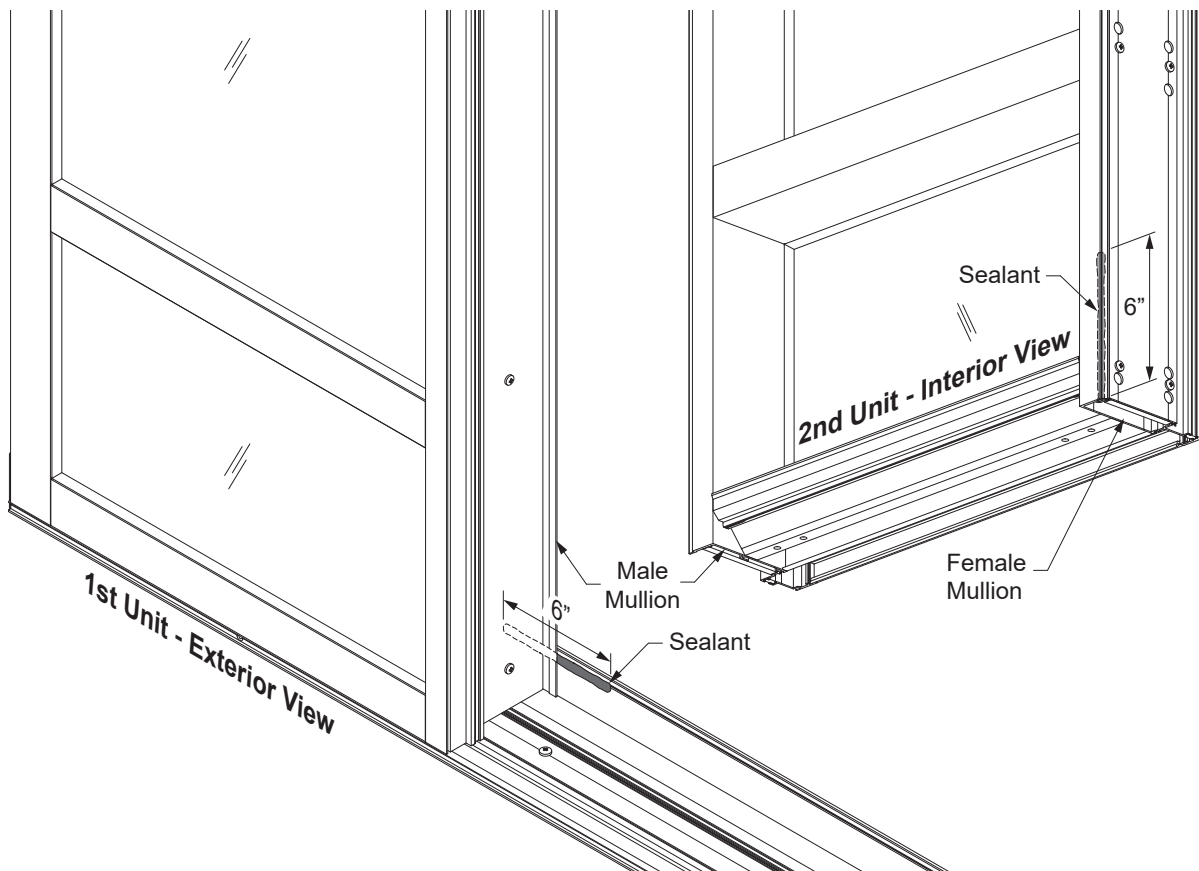

Detail 68

FRAME INSTALLATION

**STEP 31 (Continued)
INSTALL FRAMES**

- Install the next framing unit, taking care to ensure that the unit is plumb, level, square, and true, and that the female mullion fully interfaces with the male mullion from the previous unit.
 - Continue installation to the opposite jamb unit. Previously installed units can be moved (if not already fastened at the sill) to make room for the final unit.
- See **Detail 69 & 69A**.

- Fill the void between the two units at the back of the sill flashing with sealant.

See **Detail 70**.

- Repeat **Step 31** until all units are installed.

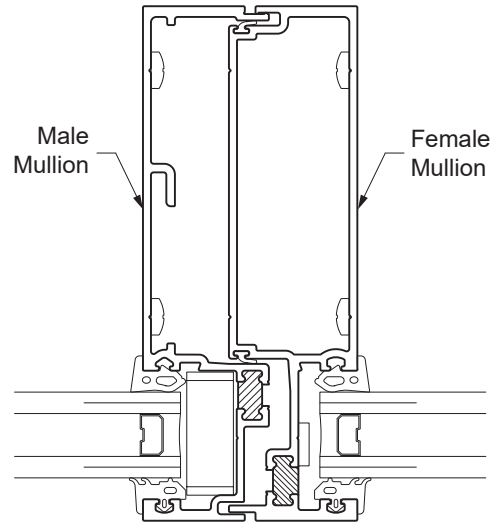

Detail 69

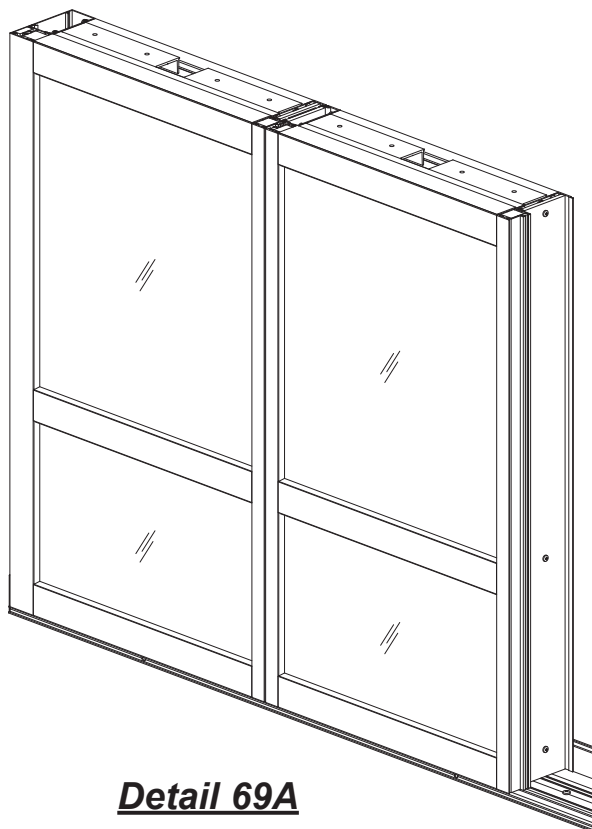

Detail 69A

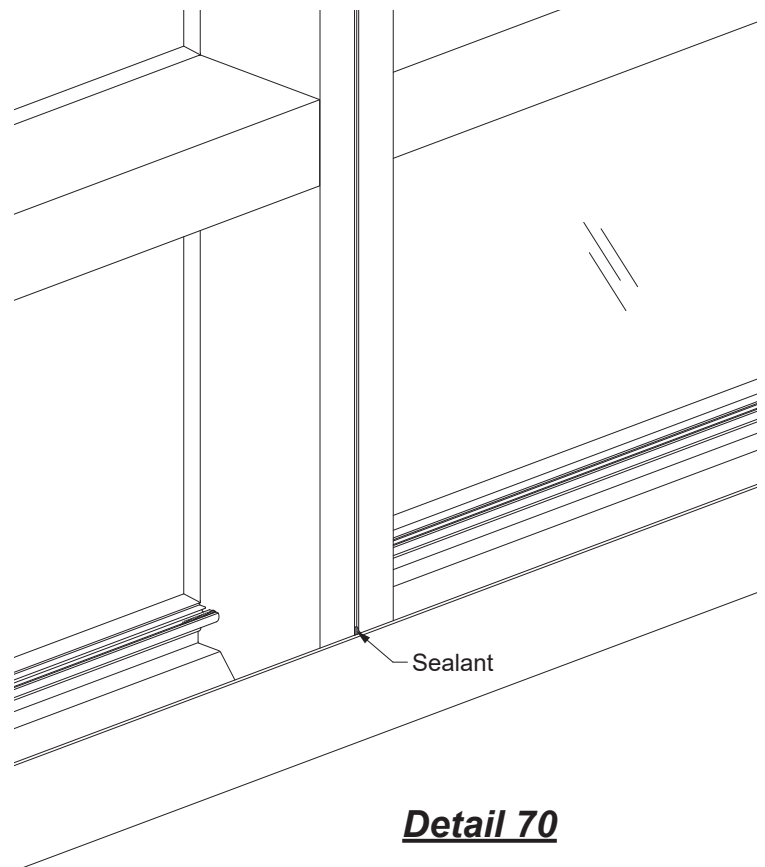

Detail 70

FRAME INSTALLATION

**STEP 32
APPLY PERIMETER SEALANT**

- Once all the units are installed, apply perimeter sealant required on interior and exterior of the window wall system.
- Install backer rod around the perimeter of the frame.
- Apply perimeter sealant to the joint between the frame and the structure.
- Avoid getting sealant into the sill flashing weep holes.

See **Detail 71**.

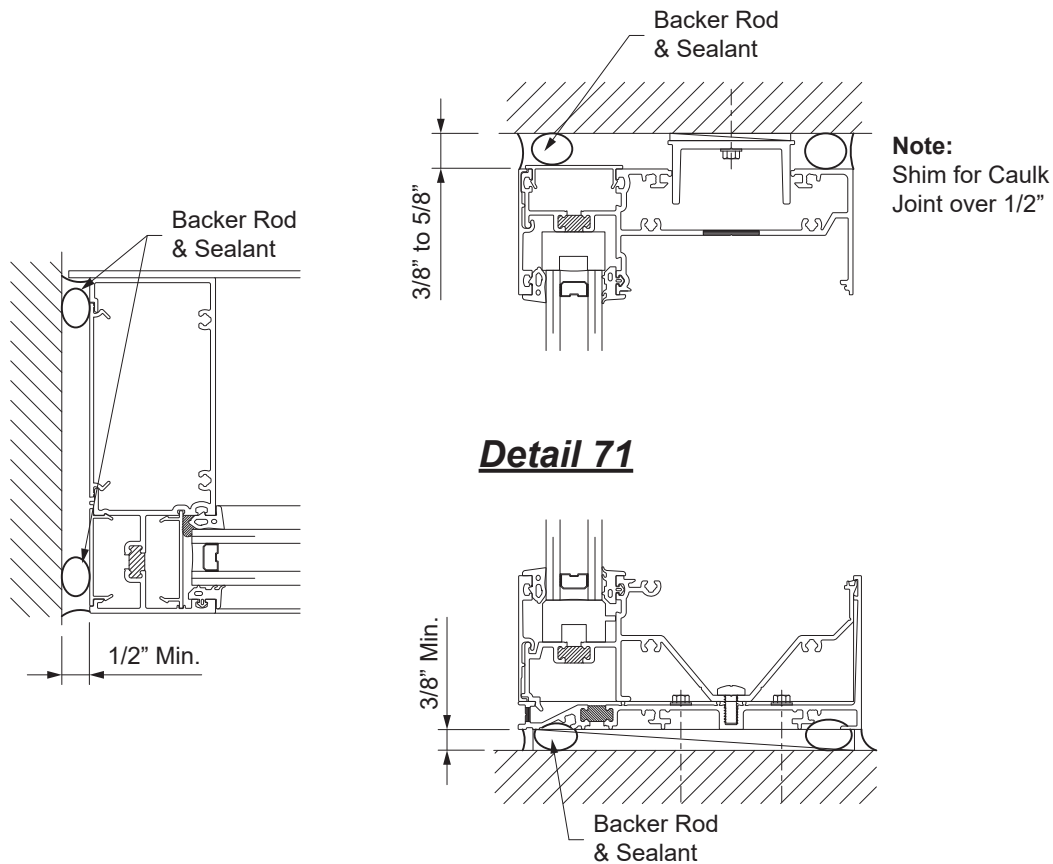

FRAME INSTALLATION**STEP 32A****APPLY PERIMETER SEALANT AT SLAB EDGE COVERS**

- For slab edge covers at the head and sill, install a backer rod and apply sealant to the back of the sill flashing and head receptor.
- Tool sealant prior to skinning over.
- Install a backer rod and seal the jamb edge of the slab edge covers.

See **Detail 72**.

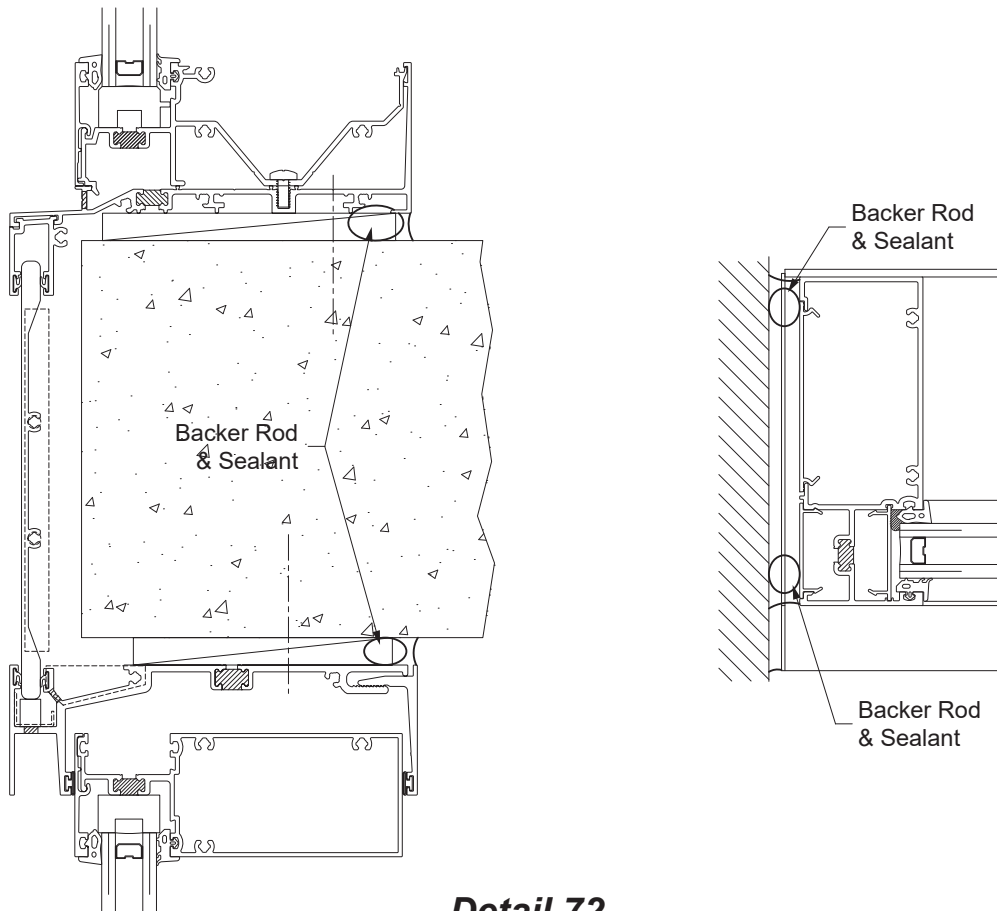

Detail 72

FRAME INSTALLATION

STEP 32B
APPLY SEALANT AT CORNER MULLIONS

-Apply backer rod and sealant the at the interior of the corner mullion, the full height of the mullion.
Do not seal the exterior side.

See **Detail 73**.

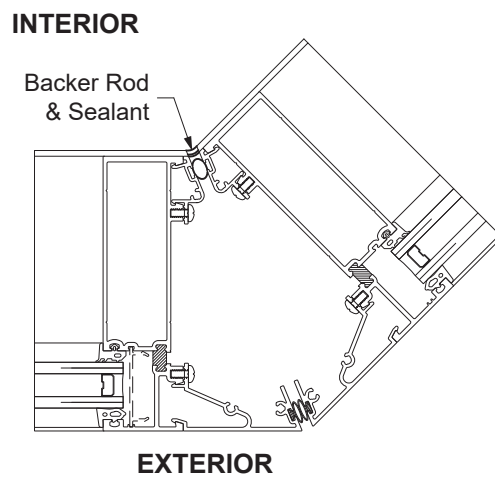
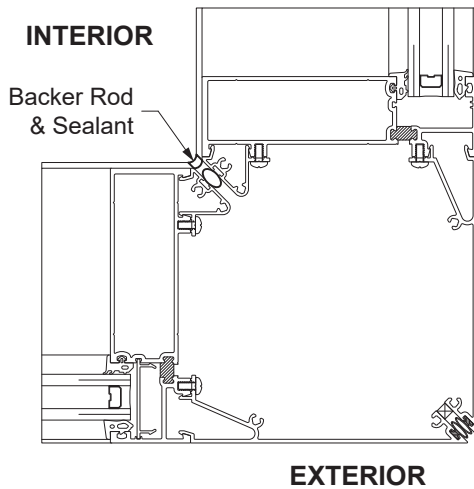

Detail 73

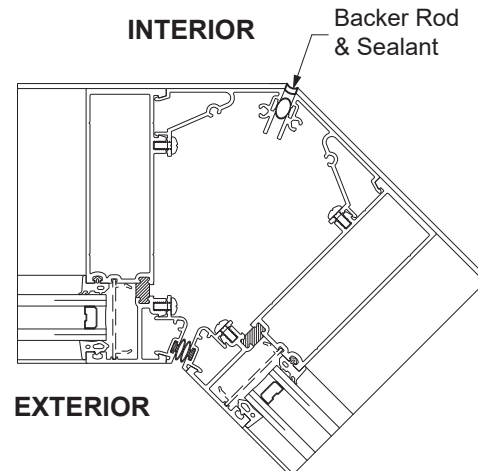
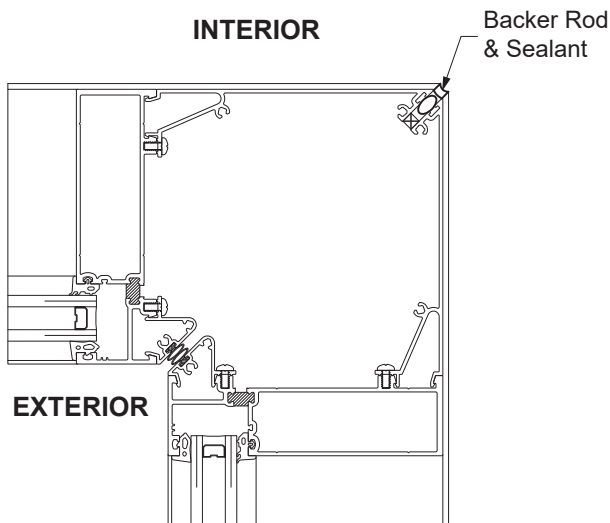

FRAME INSTALLATION

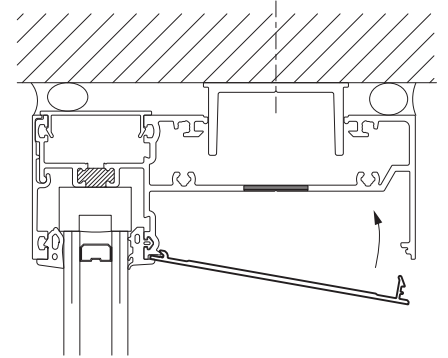
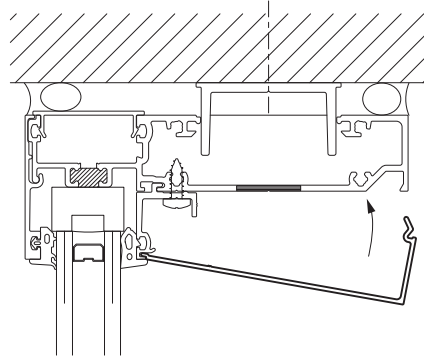

Detail 74

**STEP 33
INSTALL INTERIOR COVERS**

-Snap on the interior covers at the head, horizontals, and sills.

YWW 50 TU

E9-2782 IG head & IG horizontals

E9-2780 sill and OG head

YWW 60 TU

E9-7853 @ IG head & IG horizontals

E9-2762 @ sill and OG head

See **Details 74**.

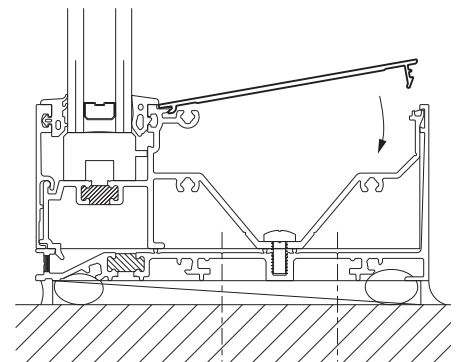
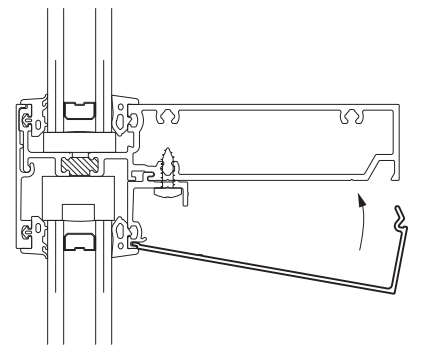

DOOR FRAME INSTALLATION

STEP 34 INSTALL DOOR FRAME

Doors are shipped assembled, and door frames will be fabricated and shipped knocked down. Please refer to the 20D, 35D, & 50D **Entrances Installation Manual** for door installation.

-Door jamb mullions are made from male and female mullions for the preglazed application, shimmed and fastened together as shown below in **Detail 76**. Spacing of fasteners to be determined by approved shop drawings and or P.E. calculations. Door transoms bars are made with tubular horizontals and BY7-9241 pocket filler (cut to transom horizontal length minus(-) 1/32") and E9-1715 glass stop.

Note: The left jamb and right jamb have different shim sizes and fasteners.

- Install the BY7-9241 flat filler (cut to length and notched as shown in **Detail 75**) into the door jamb mullions.
- Install the E9-1715 glass stop and flat filler onto the transom bar.
- Install sill flashing end dams into the ends of the sill flashing using the same method as previously shown in **Step 25 on Page 40**.

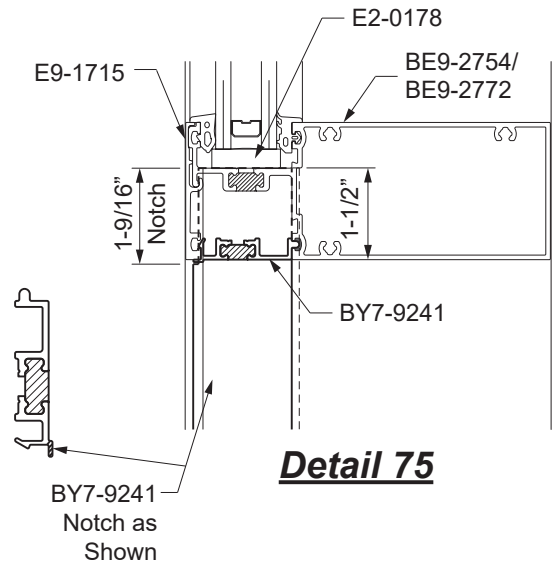

See **Detail 76**.

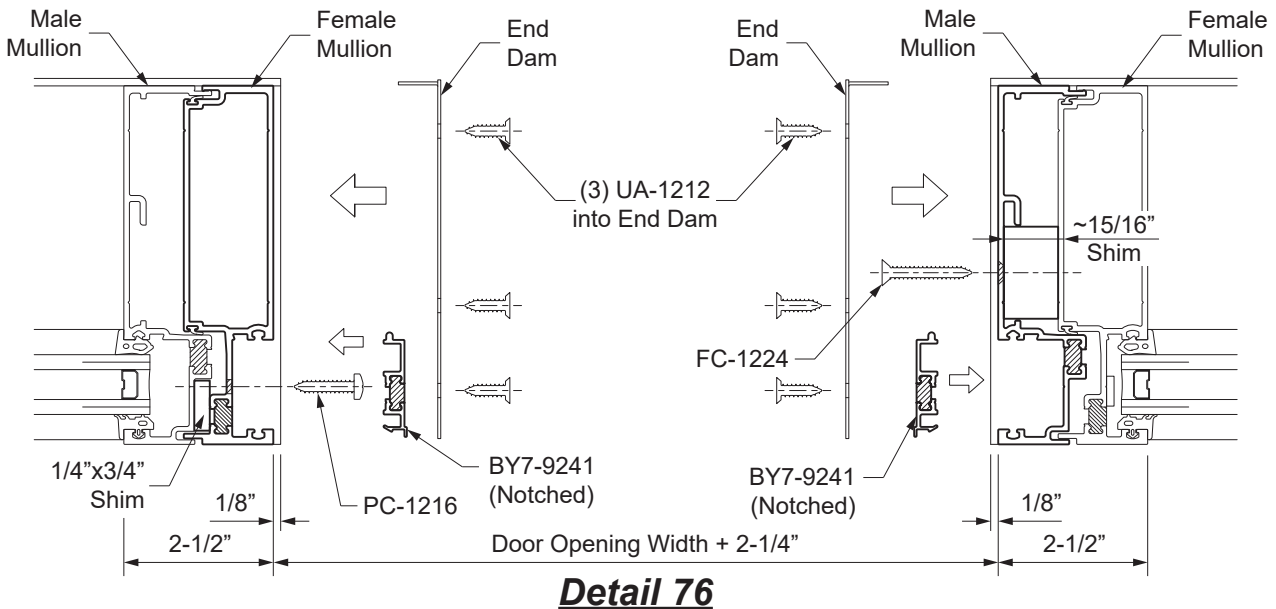

DOOR FRAME INSTALLATION

**STEP 34 (Continued)
INSTALL DOOR FRAME**

- Assemble the door subframe and install the door jamb subframes to the door jambs with PC-1220 fasteners, spaced according to the approved shop drawings and or P.E. calculations. Provide a 3/8" shim space between the jamb subframes and the jamb mullions, 1/4" shim space at the transom bar. Maintain a 1/2" inset between the subframe and the front of the window wall framing.
- Snap in the AS-0417 fillers into the door jamb subframes.

See **Details 77 & 78.**

- Install backer rods between the subframes and the window wall framing, both front and back. Apply and tool sealant to the backer rods to ensure a water-tight seal.

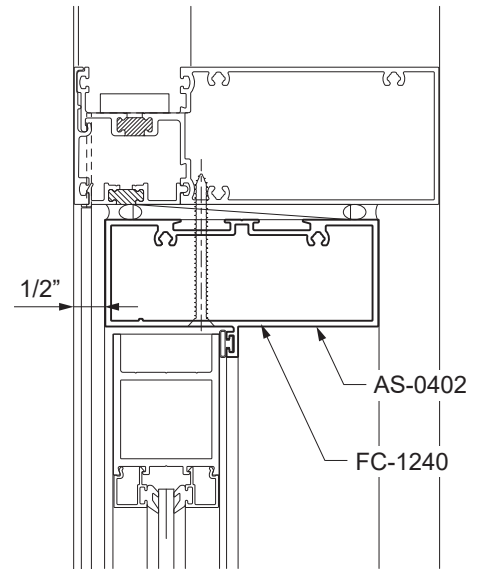

Detail 77

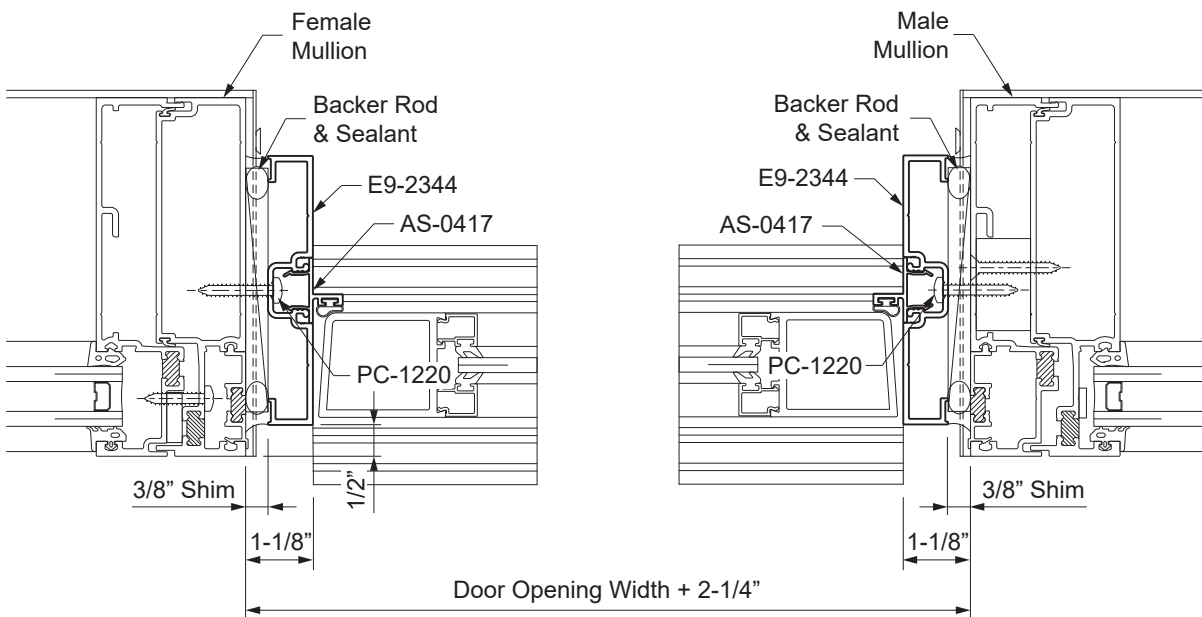

Detail 78

DOOR FRAME INSTALLATION

**STEP 35
GLAZE DOOR TRANSOM**

Door transoms for YWW 50 TU and YWW 60 TU are outside glazed only.

See **Details 79 & 80**.

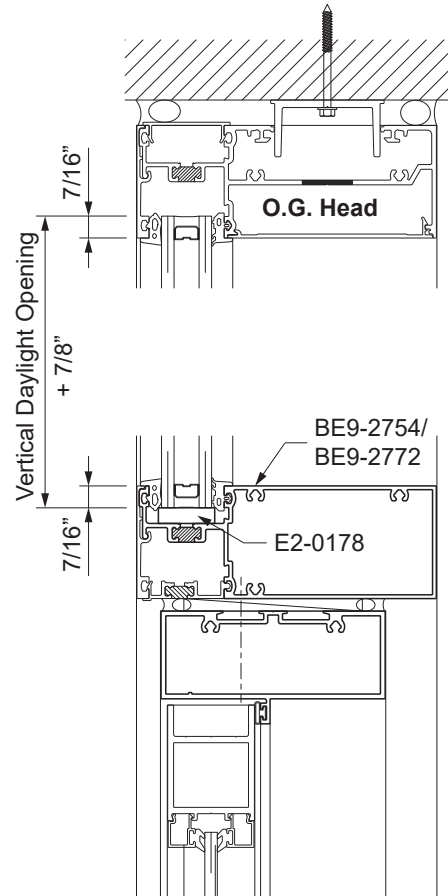

Detail 79

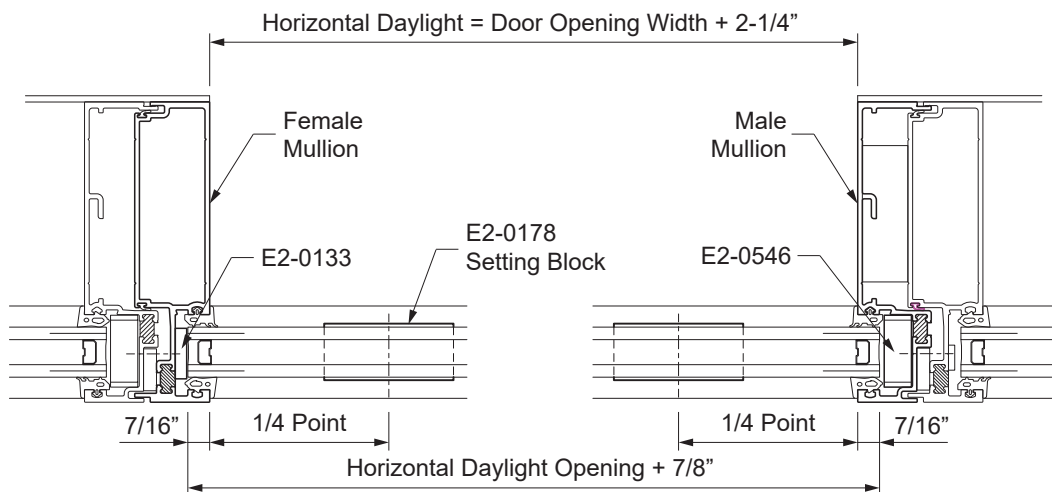

Detail 80

 **YKK AP America Inc.**

270 Riverside Parkway

Suite 100

Austell, Georgia 30168

www.ykkap.com