

**YWW 50 T Thermal Window Wall System**

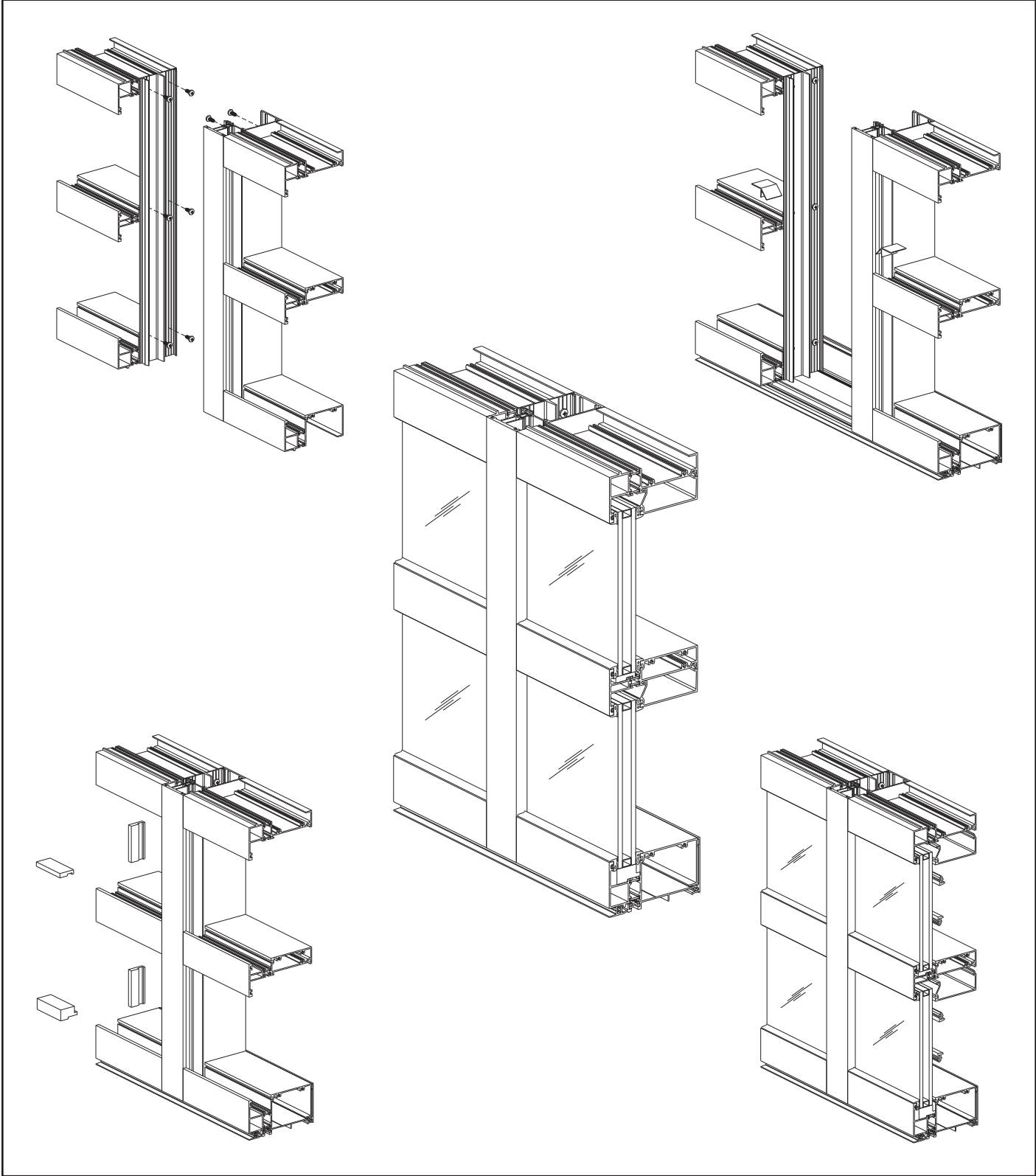

**Installation Manual**



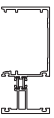

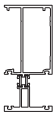
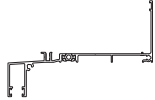

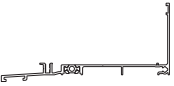
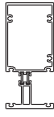

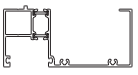
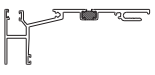
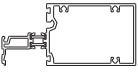

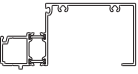
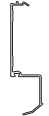





**TABLE OF CONTENTS**

Installation Notes.....	Page ii
<b>PARTS DESCRIPTION</b>	
Framing Members .....	Page 1 to 6
Door Framing Members .....	Page 7
Accessories .....	Page 8 to 10
<b>FRAME FABRICATION</b>	
Determine Frame Size .....	Page 11 & 12
Fabricate Sill Flashing .....	Page 13
Fabricate Head & Sill Members .....	Page 14 & 15
Fabricate Two Piece Verticals & Jamb Members .....	Page 16 & 17
Fabricate One Piece SSG Verticals.....	Page 17
Fabricate Interior & Exterior Glass Stops.....	Page 18 & 19
Fabricate Glazing Adaptors.....	Page 20
Fabricate Plate Adaptors.....	Page 21
Fabricate Head Receptor & Slab Edge Cover .....	Page 22
Fabricate Head Near Expansion Joint .....	Page 23
<b>FRAME ASSEMBLY</b>	
Attach Mullion End Caps.....	Page 24
Install End Dams .....	Page 24
Prepare Frames for Assembly .....	Page 25
Assemble Frames .....	Page 26
Assemble Sill Flashing .....	Page 27
Assemble Slab Edge Cover .....	Page 28
<b>FRAME INSTALLATION</b>	
Install Sill Flashing .....	Page 28 to 30
Install Corner Mullions for Vertical Through Frames .....	Page 31
Assemble and Install Head Receptor.....	Page 32 to 34
Install Slab Edge Cover.....	Page 35
Install Slab Edge Sill Flashing .....	Page 36 to 39
Install Assembled Frames .....	Page 40 & 41
Apply Internal & Perimeter Sealant.....	Page 42
Install Slab Edge Frames .....	Page 43 & 44
Apply Perimeter Sealant at Slab Edge Locations .....	Page 45 & 46
Install Water Deflectors & Horizontal Bridges .....	Page 47
Install 1/4" Glazing Adaptors .....	Page 48
<b>GLAZING</b>	
Seal Inside Glazed Horizontals .....	Page 49
Install Glazing Gaskets .....	Page 50
Install Glass for Standard Glazing .....	Page 51 to 53
Install Glass for Structural Silicone Glazing .....	Page 54 to 56
<b>DOOR FRAME INSTALLATION</b>	
Install Door Frame.....	Page 57







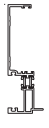

## Installation Notes

1. Do not drop, roll or drag boxes of aluminum framing. Move and stack boxes with proper support to prevent distortion. If fork lifts are used be especially careful about striking the boxes when lifting or moving.
2. Store in a dry, out of the way area. If rain exposure, condensation or any water contact is likely, then all packaging material should be removed. Wet packaging materials will discolor and may stain aluminum finishes and paints.
3. All materials should be checked for quantity and quality upon receipt, YKK AP must be notified immediately of any discrepancies in shipment. Check to make sure that you have the required shims, sealants, supplies and tools necessary for the installation.
4. Carefully check the openings and surrounding conditions that will receive your material. Remember, if the construction is not per the construction documents, it is your responsibility to notify the general contractor in writing. Any discrepancies must be brought to the general contractor's attention before you proceed with the installation.
5. Gather your shop drawings, materials, packing list and this installation manual. Carefully review parts location, the sequence it goes therein when you glaze it and how you seal it. Installation instructions are of a general nature and may not cover every condition you encounter. The shop drawings and/or installation manuals were prepared specifically for the product.
6. Any material substitutions must be of equal or greater quality.
7. Make certain that material samples have been sent for compatibility testing for all manufacturer's sealants involved. Make certain that sealants have been installed in strict accordance with the manufacturer's recommendations and specifications.
8. Remember to isolate, in an approved manner, all aluminum from uncured masonry or other incompatible materials.
9. System-to-structure fasteners are not supplied by YKK AP. Fasteners called out on shop drawings are to indicate minimum sizes for design loading.
10. Entrances are to be installed plumb, square, level and true.
11. If any questions arise concerning YKK AP products or their installation, contact YKK AP for clarification before proceeding.
12. YKK AP store front and/or curtain wall framing is typically completed before drywall, flooring and other products that may still be in process. Take the extra time to wrap and protect the work produced.
13. Cutting tolerances are plus zero, minus one thirty second unless otherwise noted.
14. Check our website, [www.ykkap.com](http://www.ykkap.com), for the latest installation manual update prior to commencing work.





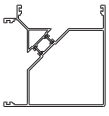

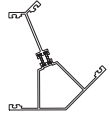



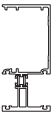

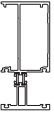
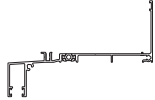

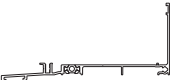
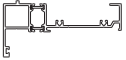

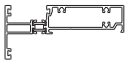
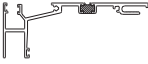
**FRAMING MEMBERS FOR OUTSIDE GLAZING**

	<b>Vertical</b>	<b>BE9-8707</b>		<b>Sill Flashing</b>	<b>BE9-2818</b>
	<b>Vertical Heavy Duty</b>	<b>BE9-8789</b>		<b>Sill Flashing With Integral Receptor</b>	<b>BE9-2812</b>
	<b>Snap-In Filler</b> Use with BE9-8707 and BE9-8789	<b>E9-8715</b>		<b>Sill Flashing</b>	<b>BE9-2814</b>
	<b>Vertical</b> For Continuous Head & Sill Construction	<b>BE9-2803</b>		<b>Slab Edge Cover Receptor</b> Use with BE9-2814	<b>E9-8222</b>
	<b>Head / Jamb</b>	<b>BE9-2816</b>		<b>Head Receptor</b>	<b>BE9-2819</b>
	<b>Horizontal</b>	<b>BE9-8728</b>		<b>Snap Cover</b> Use with BE9-2819	<b>E9-8720</b>
	<b>Sill</b>	<b>BE9-2823</b>		<b>Pocket Filler</b>	<b>BE9-8734</b>
	<b>Exterior Glass Stop</b> Use with BE9-2823 & BE9-8728	<b>E9-1715</b>		<b>Glazing Adapter</b> For 1/4" glazing Use with BE9-8734	<b>E9-1725</b>
	<b>Deep Pocket Glazing Adaptor</b> For 1/4" Glazing	<b>E9-1707</b>		<b>6-1/8" Slab Edge Cover</b> For use with 5-1/8" Slab	<b>E9-8059</b>
	<b>Shallow Pocket Glazing Adaptor</b> For 1/4" Glazing	<b>E9-1708</b>		<b>6-5/8" Slab Edge Cover</b> For use with 5-5/8" Slab	<b>E9-7723</b>

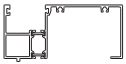









## FRAMING MEMBERS FOR OUTSIDE GLAZING

	<p><b>7-3/8" Slab Edge Cover</b> For use with 6-3/8" Slab</p>	<p><b>E9-8223</b></p>	 <p><b>Expansion Mullion Female</b> Elastomer Weathering E2-0065 not Included</p>	<p><b>BE9-8708</b></p>
	<p><b>7-7/8" Slab Edge Cover</b> For use with 6-7/8" Slab</p>	<p><b>E9-8231</b></p>	 <p><b>Expansion Mullion Male</b></p>	<p><b>BE9-2827</b></p>
	<p><b>8" Slab Edge Cover</b> For use with 7" Slab</p>	<p><b>E9-8589</b></p>	 <p><b>Slip-On Face Cap</b> Use with BE9-2827</p>	<p><b>E9-1763</b></p>
	<p><b>9" Slab Edge Cover</b> For use with 8" Slab</p>	<p><b>E9-8428</b></p>	 <p><b>Hinged Mullion Female</b></p>	<p><b>BE9-7912</b></p>
	<p><b>90° Corner Mullion</b> Use with (2) BE9-8734</p>	<p><b>BE9-8731</b></p>	 <p><b>Outside Hinged Mullion Male</b> 3° to 20°</p>	<p><b>BE9-7911</b></p>
	<p><b>135° Outside Corner Mullion</b> Use with (2) BE9-8734</p>	<p><b>BE9-8725</b></p>		





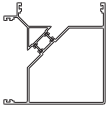

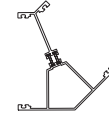







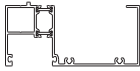

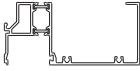
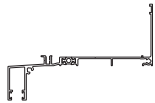
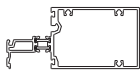
**FRAMING MEMBERS FOR INSIDE GLAZING**

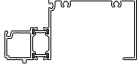
	<b>Vertical</b>	<b>BE9-8707</b>		<b>Sill Flashing</b>	<b>BE9-2818</b>
	<b>Vertical Heavy Duty</b>	<b>BE9-8789</b>		<b>Sill Flashing With Integral Receptor</b>	<b>BE9-2812</b>
	<b>Snap-In Filler</b> Use with BE9-8707	<b>E9-8715</b>		<b>Sill Flashing</b>	<b>BE9-2814</b>
	<b>Head</b> For vertical through applications	<b>BE9-8703</b>		<b>Slab Edge Cover Receptor</b> Use with BE9-2814	<b>E9-8222</b>
	<b>Horizontal</b>	<b>BE9-8704</b>		<b>Head Receptor</b>	<b>BE9-2819</b>
	<b>Glass Stop</b> For 1" Glazing Use with BE9-8703 & BE9-8704	<b>E9-8711</b>		<b>Snap Cover</b> Use with BE9-2819	<b>E9-8720</b>
	<b>Glass Stop</b> For 1/4" Glazing Use with BE9-8703 & BE9-8704	<b>E9-7703</b>		<b>Pocket Filler</b>	<b>BE9-8734</b>
	<b>Sill / Jamb</b>	<b>BE9-2816</b>		<b>Glazing Adapter</b> For 1/4" glazing Use with BE9-8734	<b>E9-1725</b>
	<b>Deep Pocket Glazing Adaptor</b> For 1/4" Glazing	<b>E9-1707</b>		<b>6-1/8" Slab Edge Cover</b> For use with 5-1/8" Slab	<b>E9-8059</b>
	<b>Shallow Pocket Glazing Adaptor</b> For 1/4" Glazing	<b>E9-1708</b>		<b>6-5/8" Slab Edge Cover</b> For use with 5-5/8" Slab	<b>E9-7723</b>

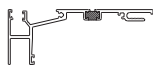





## FRAMING MEMBERS FOR INSIDE GLAZING

	<p><b>7-3/8" Slab Edge Cover</b> For use with 6-3/8" Slab</p>	<p><b>E9-8223</b></p>	 <p><b>Expansion Mullion Female</b> Elastomer Weathering E2-0065 not Included</p>	<p><b>BE9-8708</b></p>
	<p><b>7-7/8" Slab Edge Cover</b> For use with 6-7/8" Slab</p>	<p><b>E9-8231</b></p>	 <p><b>Expansion Mullion Male</b></p>	<p><b>BE9-2827</b></p>
	<p><b>8" Slab Edge Cover</b> For use with 7" Slab</p>	<p><b>E9-8589</b></p>	 <p><b>Slip-On Face Cap</b> Use with BE9-2827</p>	<p><b>E9-1763</b></p>
	<p><b>9" Slab Edge Cover</b> For use with 8" Slab</p>	<p><b>E9-8428</b></p>	 <p><b>Hinged Mullion Female</b></p>	<p><b>BE9-7912</b></p>
	<p><b>90° Corner Mullion</b> Use with (2) BE9-8734</p>	<p><b>BE9-8731</b></p>	 <p><b>Outside Hinged Mullion Male</b> 3° to 20°</p>	<p><b>BE9-7911</b></p>
	<p><b>135° Outside Corner Mullion</b> Use with (2) BE9-8734</p>	<p><b>BE9-8725</b></p>		







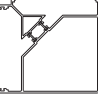



**FRAMING MEMBERS FOR STRUCTURAL SILICONE GLAZING**

	<b>Vertical</b> For Structural Silicone Glazing	<b>E9-2805</b>		<b>SSG Expansion Mullion Female</b>	<b>E9-2824</b>
	<b>Glazing Adaptor</b> For 1/4" Glazing Use with E9-2805	<b>E9-2716</b>		<b>SSG Expansion Mullion Male</b>	<b>E9-2825</b>
	<b>Head / Jamb / Sill</b>	<b>BE9-2816</b>		<b>Sill Flashing</b>	<b>BE9-2818</b>
	<b>Head</b> For Spliced Runs Longer than 24'-0"	<b>BE9-2801</b>		<b>Sill Flashing With Integral Receptor</b>	<b>BE9-2812</b>
	<b>Horizontal</b>	<b>BE9-8728</b>		<b>Sill Flashing</b>	<b>BE9-2814</b>
	<b>Sill</b> For Spliced Runs Longer than 24'-0"	<b>BE9-2823</b>		<b>Slab Edge Cover Receptor</b> Use with BE9-2814	<b>E9-8222</b>
	<b>Exterior Glass Stop</b> Use with BE9-8728 & BE9-8706	<b>E9-1715</b>		<b>Head Receptor</b>	<b>BE9-2819</b>
	<b>Exterior Glass Stop</b> Use with BE9-2801	<b>E9-1730</b>		<b>Snap Cover</b> Use with BE9-2819	<b>E9-8720</b>
	<b>Deep Pocket Glazing Adaptor</b> For 1/4" Glazing	<b>E9-1707</b>		<b>Pocket Filler</b>	<b>BE9-8734</b>
	<b>Glazing Adaptor</b> For 1/4" Glazing	<b>E9-1708</b>		<b>Glazing Adaptor</b> For 1/4" glazing Use with BE9-8734	<b>E9-1725</b>

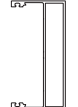





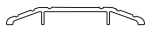

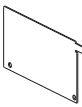

## FRAMING MEMBERS FOR STRUCTURAL SILICONE GLAZING

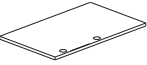
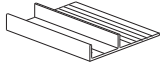
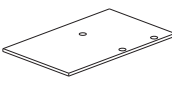
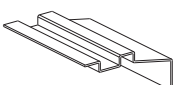
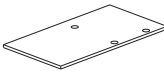
 <p><b>6-1/8" Slab Edge Cover</b> For use with 5-1/8" Slab</p>	<p><b>E9-8059</b></p>	 <p><b>8" Slab Edge Cover</b> For use with 7" Slab</p>	<p><b>E9-8589</b></p>
 <p><b>6-5/8" Slab Edge Cover</b> For use with 5-5/8" Slab</p>	<p><b>E9-7723</b></p>	 <p><b>9" Slab Edge Cover</b> For use with 8" Slab</p>	<p><b>E9-8428</b></p>
 <p><b>7-3/8" Slab Edge Cover</b> For use with 6-3/8" Slab</p>	<p><b>E9-8223</b></p>	 <p><b>90° Corner Mullion</b> For structural silicone glazing</p>	<p><b>E9-2821</b></p>
 <p><b>7-7/8" Slab Edge Cover</b> For use with 6-7/8" Slab</p>	<p><b>E9-8231</b></p>	 <p><b>90° Corner Mullion</b> Use with (2) BE9-8734</p>	<p><b>BE9-8731</b></p>

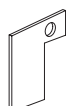
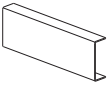
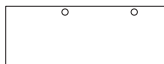
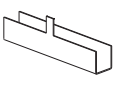

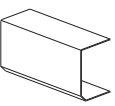
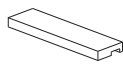

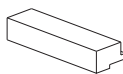
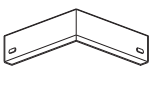





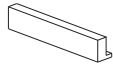

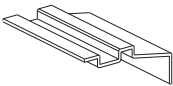

**DOOR FRAMING MEMBERS**

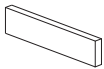
	<p><b>Single Acting Door Jamb</b> 2-1/4" x 5" Elastomer Weathering E2-0051 Included</p>	<p><b>AS-2807</b></p>	 <p><b>Glazing Pocket Flush Filler</b> For 1" Glazing</p>	<p><b>BE9-7856</b></p>
	<p><b>Single Acting Transom Bar</b> 2-1/4" x 5" E2-0051 Included</p>	<p><b>AS-2808</b></p>	 <p><b>Glazing Pocket Flush Filler</b> For 1" Glazing</p>	<p><b>BE9-2721</b></p>
	<p><b>Double Acting Door Jamb</b> 2-1/4" x 5"</p>	<p><b>E9-2809</b></p>	 <p><b>Glazing Adaptor</b> For 1/4" Glazing Use with BE9-8734 &amp; E9-1721</p>	<p><b>E9-1725</b></p>
	<p><b>Double Acting Transom Bar</b> 2-1/4" x 5" E2-0062 Included</p>	<p><b>AS-2810</b></p>	 <p><b>Transom Glazing Pocket</b> For 1" Glazing</p>	<p><b>E9-1721</b></p>
	<p><b>Intermediate Door Jamb</b> 2" x 5" Tube Use with AS-0401 Door Stop</p>	<p><b>E9-8439</b></p>	 <p><b>Door Stop Assembly</b> E9-0409 &amp; E9-1113 (Mill) Elastomer Weathering E2-0051 Included</p>	<p><b>AS-0401</b></p>
	<p><b>Jamb Filler</b></p>	<p><b>BE9-8734</b></p>	 <p><b>Threshold</b> 1/2" x 4"</p>	<p><b>E9-0407</b></p>



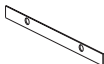

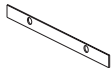
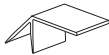
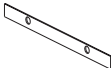

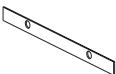











## ACCESSORIES

 <p><b>Shear Block</b> For BE9-8728 Horizontal Use (2) PC-1228 &amp; (2) FC-1212 not Included</p>	<p><b>E1-2802</b></p>	 <p><b>End Dam</b> For BE9-2818 Sill Flashing</p>	<p><b>E1-2808</b></p>
 <p><b>Shear Clip</b> For BE9-8704 Horizontal Use (4) PC-1210 not Included</p>	<p><b>E1-2801</b></p>	 <p><b>SSG Mullion End Cap</b></p>	<p><b>E1-2805</b></p>
 <p><b>"F" Anchor</b> For Head &amp; Jamb</p>	<p><b>E1-2803</b></p>	 <p><b>Expansion Mullion End Cap</b></p>	<p><b>E1-2806</b></p>
 <p><b>Splice Sleeve</b> For Head Receptor</p>	<p><b>E1-2813</b></p>	 <p><b>Standard Mullion End Cap</b></p>	<p><b>E1-2809</b></p>
 <p><b>Splice Sleeve</b> For Sill Flashing and Head Receptor</p>	<p><b>E2-0070</b></p>	 <p><b>End Cap</b> For Sill Flashing</p>	<p><b>E1-9951</b></p>
 <p><b>Joint Sleeve</b> For Head &amp; Sill (Forward Chamber)</p>	<p><b>E1-1027</b></p>	 <p><b>End Cap</b> For Head Receptor</p>	<p><b>E1-9952</b></p>
 <p><b>Joint Sleeve</b> For SSG Head &amp; Sill (Forward Chamber)</p>	<p><b>E1-1028</b></p>	 <p><b>End Cap</b> For Head Receptor</p>	<p><b>E1-9957</b></p>
 <p><b>Joint Sleeve</b> For Head &amp; Sill (Rear Chamber)</p>	<p><b>E1-2804</b></p>	 <p><b>Setting Block / Side Block</b> 1" Glazing</p>	<p><b>E2-0184</b></p>
 <p><b>Water Deflector</b> For Horizontals at Structural Silicone Glazed Verticals</p>	<p><b>E1-1038</b></p>	 <p><b>Setting Block</b> For Sill 1" Glazing</p>	<p><b>E2-0182</b></p>
 <p><b>Water Deflector</b> For Horizontals at 90° Structural Silicone Glazed Corners</p>	<p><b>E1-1039</b></p>	 <p><b>Setting Block</b> For Horizontal 1/4" Glazing</p>	<p><b>E2-0192</b></p>

ACCESSORIES

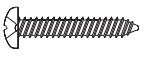
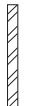
	<b>Setting Block</b> For Sill 1/4" Glazing	<b>E2-0190</b>		<b>End Dam</b> For Frame Ends Where Head & Sill Run Through	<b>E2-0194</b>
	<b>Setting Block</b> Use with BE9-2819	<b>E2-0054</b>		<b>Reinforcement</b> Use with BE9-2819	<b>E1-2812</b>
	<b>Weep Baffle</b>	<b>E2-0098</b>		<b>Temporary Glass Retainer</b> For 1" Structural Silicone Glazing	<b>E3-0001</b>
	<b>Weep Baffle</b>	<b>E2-0099</b>		<b>Temporary Glass Retainer</b> For 1/4" Structural Silicone Glazing	<b>E3-0006</b>
	<b>Side Block</b>	<b>E2-0186</b>		<b>End Cap</b> Use with E9-8059	<b>E1-9984</b>
	<b>Side Block</b>	<b>E2-0537</b>		<b>End Cap</b> Use with E9-7723	<b>E1-9985</b>
	<b>Anti-Walk Block</b> For Deep Pocket	<b>E2-0153</b>		<b>End Cap</b> Use with E9-8223	<b>E1-9953</b>
	<b>Anti-Walk Block</b>	<b>E2-0546</b>		<b>End Cap</b> Use with E9-8231	<b>E1-9954</b>
	<b>Water Deflector</b>	<b>E2-0047</b>		<b>End Cap</b> Use with E9-8589	<b>E1-9955</b>
	<b>End Dam</b> For Frame Ends Where Head & Sill Run Through	<b>E2-0193</b>		<b>End Cap</b> Use with E9-8428	<b>E1-9956</b>

## ACCESSORIES

	<b>Push-In Glazing Gasket</b>	<b>E2-0801</b>		<b>#10 x 3/8" FHSMS Type AB</b> Zinc Plated Steel For Attachment of Mullion End Caps	<b>FC-1006</b>
	<b>Wedge Glazing Gasket</b>	<b>E2-0808</b>		<b>#12 x 3/4" UFHSMS Type A</b> , Zinc Plated Steel, For End Dam Attachment	<b>UA-1212</b>
	<b>Push-In Glazing Gasket</b> For SSG Glazing	<b>E2-0541</b>		<b>#10 x 3/8" PHSMS-SS</b> <b>Type AB</b> , Stainless Steel For Attachment of Head Receptor Splice	<b>PC-1006-SS</b>
	<b>Wedge Glazing Gasket</b> For SSG Glazing	<b>E2-0542</b>		<b>#10 x 5/8" PHSMS Type AB</b> Zinc Plated Steel For Attachment of E9-1724 Adaptor	<b>PC-1010</b>
	<b>SSG Glazing Spacer</b> For Inside Glazing	<b>E2-0543</b>		<b>#12 x 3/4" FHSMS Type AB</b> Zinc Plated Steel For Attachment of Horizontal to Shear Block E1-1037	<b>FC-1212</b>
	<b>SSG Glazing Spacer</b> For Outside Glazing	<b>E2-0544</b>		<b>#12 x 5/8" PHSMS Type AB</b> Zinc Plated Steel, For Attachment of Shear Clip E1-1040 to Vertical & Horizontal	<b>PC-1210</b>
	<b>Weathering Gasket</b> For Expansion Mullion	<b>E2-0065</b>		<b>#12 x 1" PHSMS Type AB</b> Zinc Plated Steel For Screw Spline Attachment	<b>PC-1216</b>
	<b>Airtight Gasket</b> For Head Receptor	<b>E2-0051</b>		<b>#12 x 1-1/4" PHSMS Type AB</b> Zinc Plated Steel, For Screw Spline Attachment When Using BE9-1704 as Jamb	<b>PC-1220</b>
	<b>Steel Reinforcing</b> 3/16" x 2-3/4" Use with E9-8443, E9-2805	<b>E1-2811</b>		<b>#12 x 1-3/4" PHSMS</b> <b>Type AB</b> , Zinc Plated Steel For Attachment of Shear Block E1-2802 to Vertical	<b>PC-1228</b>
	<b>Drill Fixture</b>	<b>H-7250</b>		<b>#10 x 3/8" PHMS</b> Stainless Steel, For Attachment of Sill Flashing	<b>PM-1006-SS</b>
	<b>#8 x 1/2" FHSMS Type AB</b> Zinc Plated Steel For Attachment of Hinged Mullions	<b>FC-0808</b>			

FRAME FABRICATION

STEP 1  
DETERMINE FRAME SIZE

Determine Frame Width:

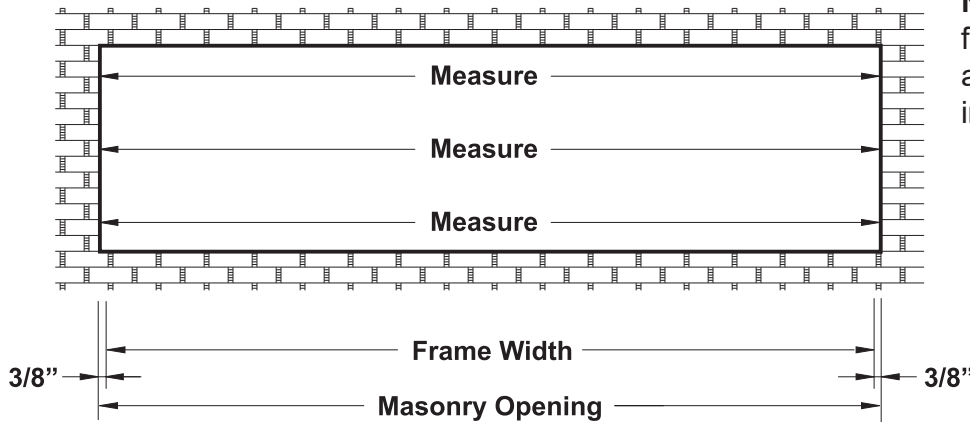

**Note:** Check the opening for squareness and plumb at both ends. Units must be installed in a true rectangle.

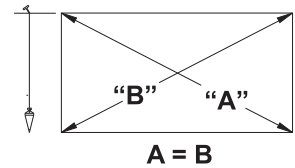

**Detail 1**

- Measure the width of the masonry opening at the top, middle, and bottom.
  - Select the smallest dimension measured and subtract 3/4" to determine the frame width.
- See **Detail 1**.

Determine Frame Height:

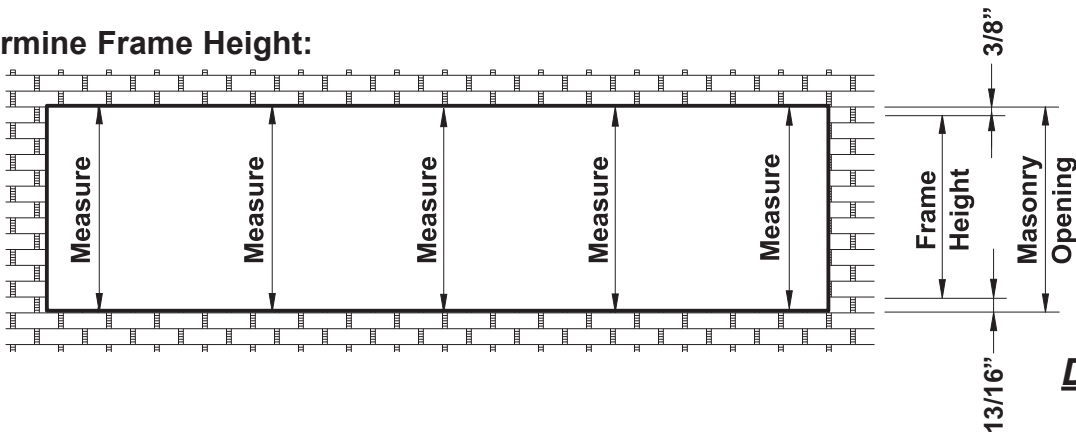

**Detail 2**

- Measure the height of the masonry opening in several places along the entire length of the opening.
- Select the smallest dimension measured and subtract 1-3/16" to determine the frame height to be used:
  - 3/8" for the shim/caulk joint at the head.
  - 7/16" for the sill flashing.
  - 3/8" for the shim/caulk joint below the sill flashing.

See **Detail 2**.

**NOTE:** Vertical through frame widths over 24'-0" require expansion mullions every 12 to 15 feet (best location at vertical next to the door jamb.)

## FRAME FABRICATION

### STEP 1 (Continued) DETERMINE FRAME SIZE

Determine Frame Height for Slab Edge Conditions:

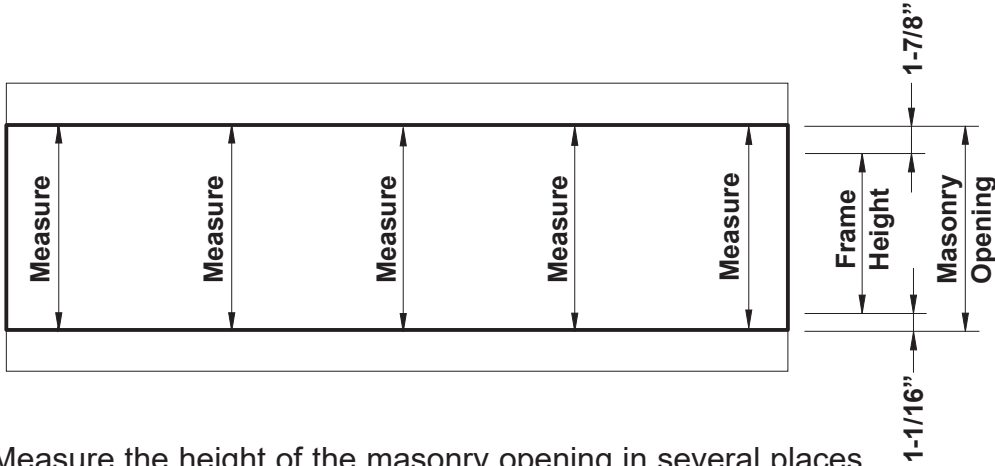

### Detail 3

- Measure the height of the masonry opening in several places along the entire length of the opening.
- Select the smallest dimension measured and subtract 2-15/16" to determine the frame height to be used:
  - 5/8" for the shim/caulk joint at the head.
  - 1-1/4" for the head receptor.
  - 7/16" for the sill flashing.
  - 5/8" for the shim/caulk joint below the sill flashing.

See **Detail 3**.

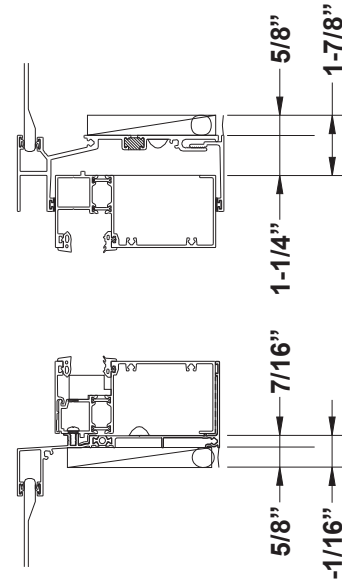

## FRAME FABRICATION

### STEP 2 FABRICATE SILL FLASHING

YWW 50 T requires the use of extruded sill flashing for vertical through frames:

- Cut the sill flashing, BE9-2812, BE9-2818, BE9-2814 as determined in **Step 1**: Frame width plus(+) 1/4" at each jamb.
- For openings longer than 24'-0" the sill flashing needs to be spliced every twelve to fifteen feet.
- Allow for a 3/8" splice joint between sill flashing members.
- Mark the centerline of each vertical mullion on the sill flashing.

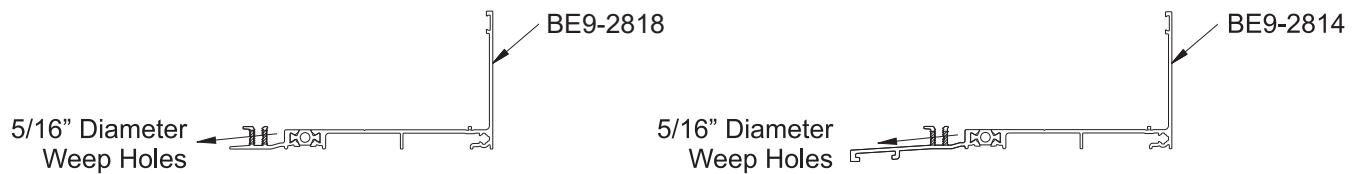
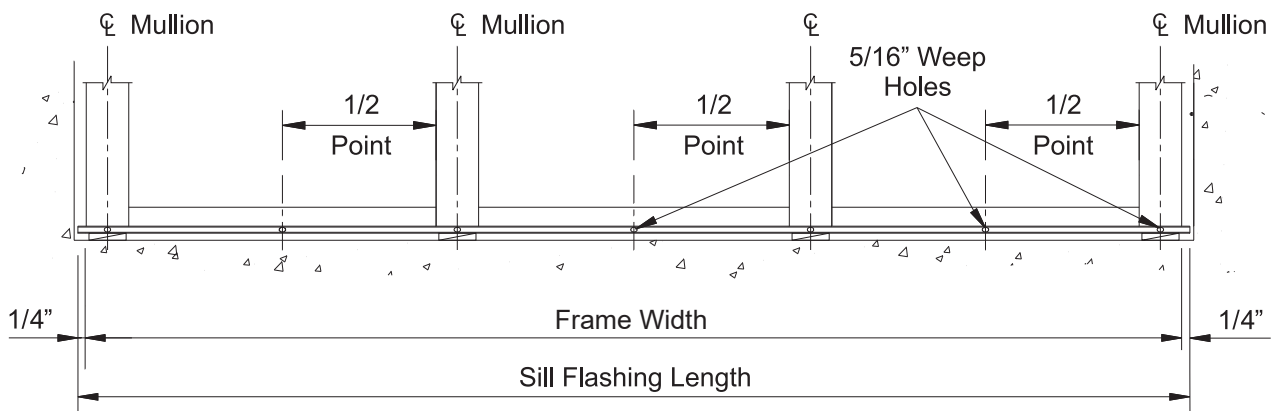

#### **Detail 4**

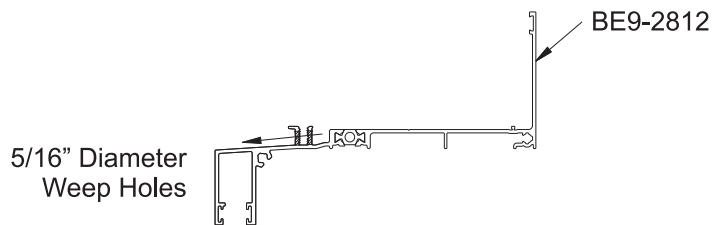

- Drill a 5/16" diameter weep hole in the face of the sill flashing at the centerline of each vertical mullion and at the midpoints between vertical mullions.

See **Detail 4**.

**NOTE:** Sill flashing is required for installation. Head and sill members do not run continuous for this system.

## FRAME FABRICATION

### STEP 3 FABRICATE HEAD & SILL MEMBERS

#### FOR VERTICAL THROUGH FRAMES

-Cut all head and sill members to the daylight opening between verticals.

Sill members require additional fabrication for anchoring to the sill flashing.

- Measure in 6" from each end of the sill member and mark hole locations along the glazing pocket "V"-groove.
- Mark additional hole locations a maximum of 24" on center (O.C.).
- Drill 0.213" diameter (#3 drill bit) holes at the underside of the "V" groove.
- Drill 7/16" diameter access holes at the top of the sill.

See **Detail 5**.

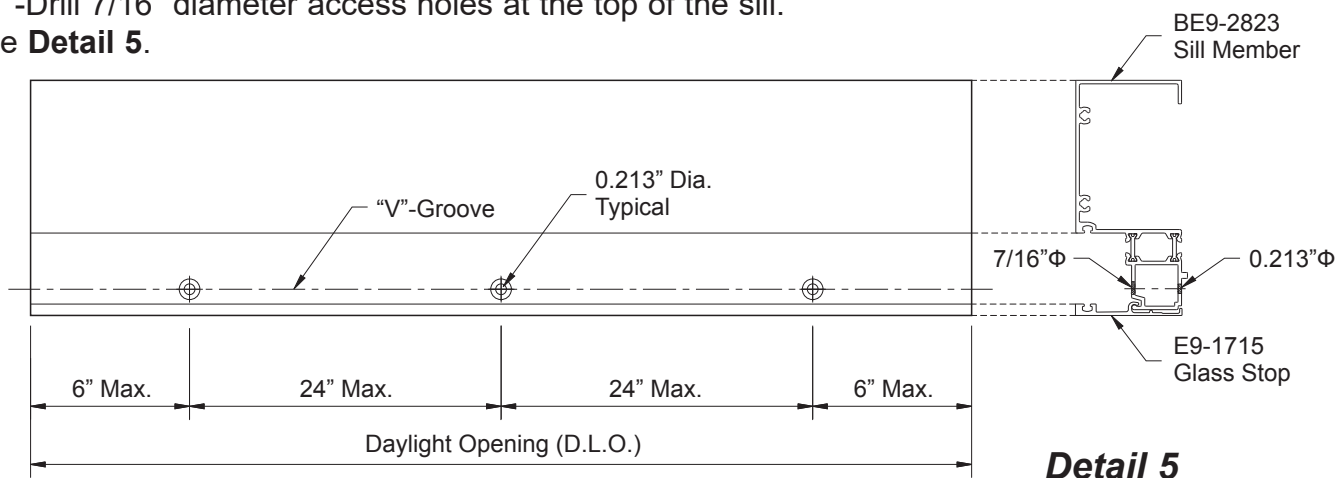

#### FOR CONTINUOUS HEAD & SILL FRAMES (YWW 50 T SSG Only)

With the YWW 50 T Structural Silicone Glazed (SSG) option, head and sill members may run continuously across the frame.

##### For Frames 24'-0" or shorter:

- Cut the head and sill members, BE9-2816, to the frame width determined in **Step 1**.

##### For Frames Longer Than 24'-0":

- Head member BE9-2801 and sill member BE9-2823 must be used instead of BE9-2816.
- Determine the location of the expansion mullions from the shop drawings (typically ten to fifteen feet on center).
- Cut the head and sill members to the dimension between the jamb and expansion mullions at end members and between the expansion mullions for intermediate members.

FRAME FABRICATION

STEP 3 (Continued)

FABRICATE HEAD & SILL MEMBERS

FOR CONTINUOUS HEAD & SILL FRAMES (YWW 50 T SSG Only)

- Mark the centerline of each SSG vertical member along the head and sill members.
- Mark hole locations on the head and sill members for screw spline attachment of vertical members using one of the methods below:

-Using short pieces of vertical members as a template, align the template with the vertical centerline and the front of the head/sill and mark hole locations through the screw splines.

OR

-Layout hole locations on head and sill members as shown in **Detail 6**.

- Drill 0.236" diameter (#B drill bit) clearance holes at each location marked.

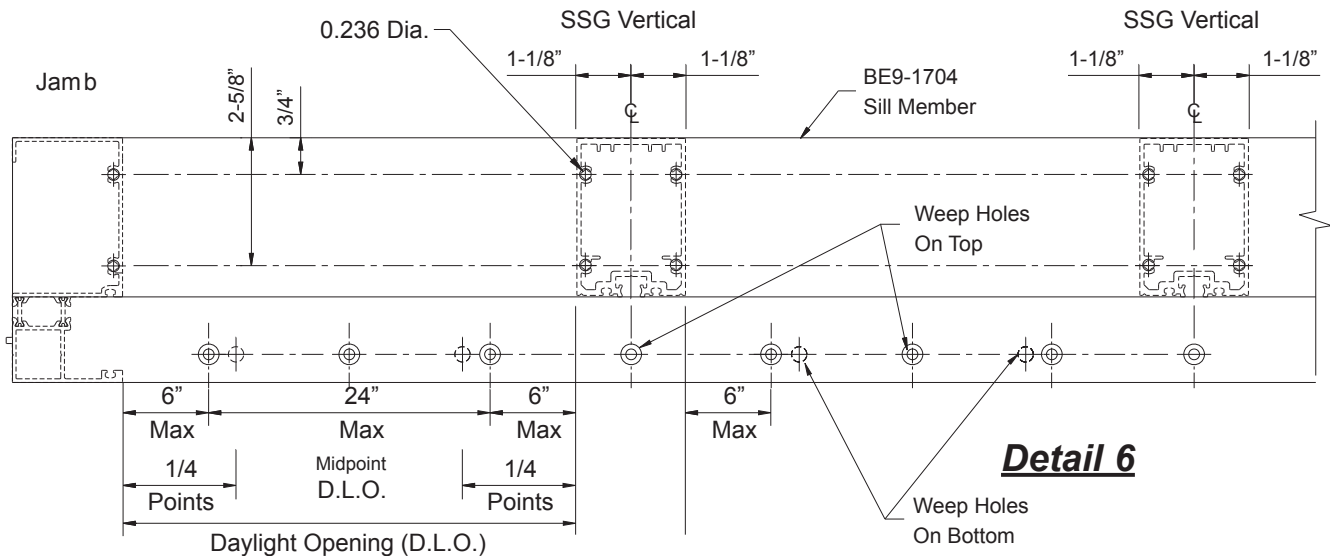

**Detail 6**

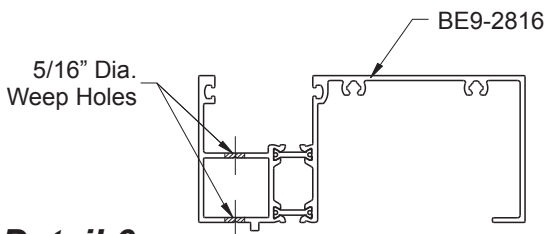

**Detail 6**

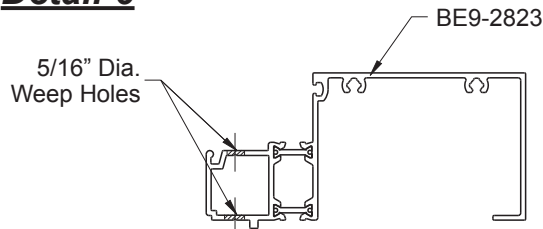

Continuous sill members must have weep holes drilled for each lite of glass.

- Mark the centerline of each intermediate vertical and the midpoint of D.L.O. between verticals in the glazing pocket of the sill.
- Turn the sill member over and mark the quarter points of D.L.O. between verticals on the bottom.
- Drill a 5/16" dia. hole at each hole location marked just in front of the thermal break.

See **Detail 6**.

## FRAME FABRICATION

### STEP 4

### FABRICATE TWO PIECE VERTICALS & JAMB MEMBERS

-Cut two piece verticals, fillers, and jamb members to the frame height determined in **Step 1** on **Page 11** or as shown on approved shop drawings.

#### Fabrication of Verticals for Inside Glazed Frames:

- Use a short piece of each horizontal member as a template.
- Center the template on the face of the vertical member.
- Line up the glazing pockets and mark the location of each screw spline.

**-OR-**

- Layout the hole locations along the "V"-grooves of each member as shown in **Detail 7**.
- Drill a 0.234" diameter hole at each location marked.

**Note:** Drill fixture can be used.

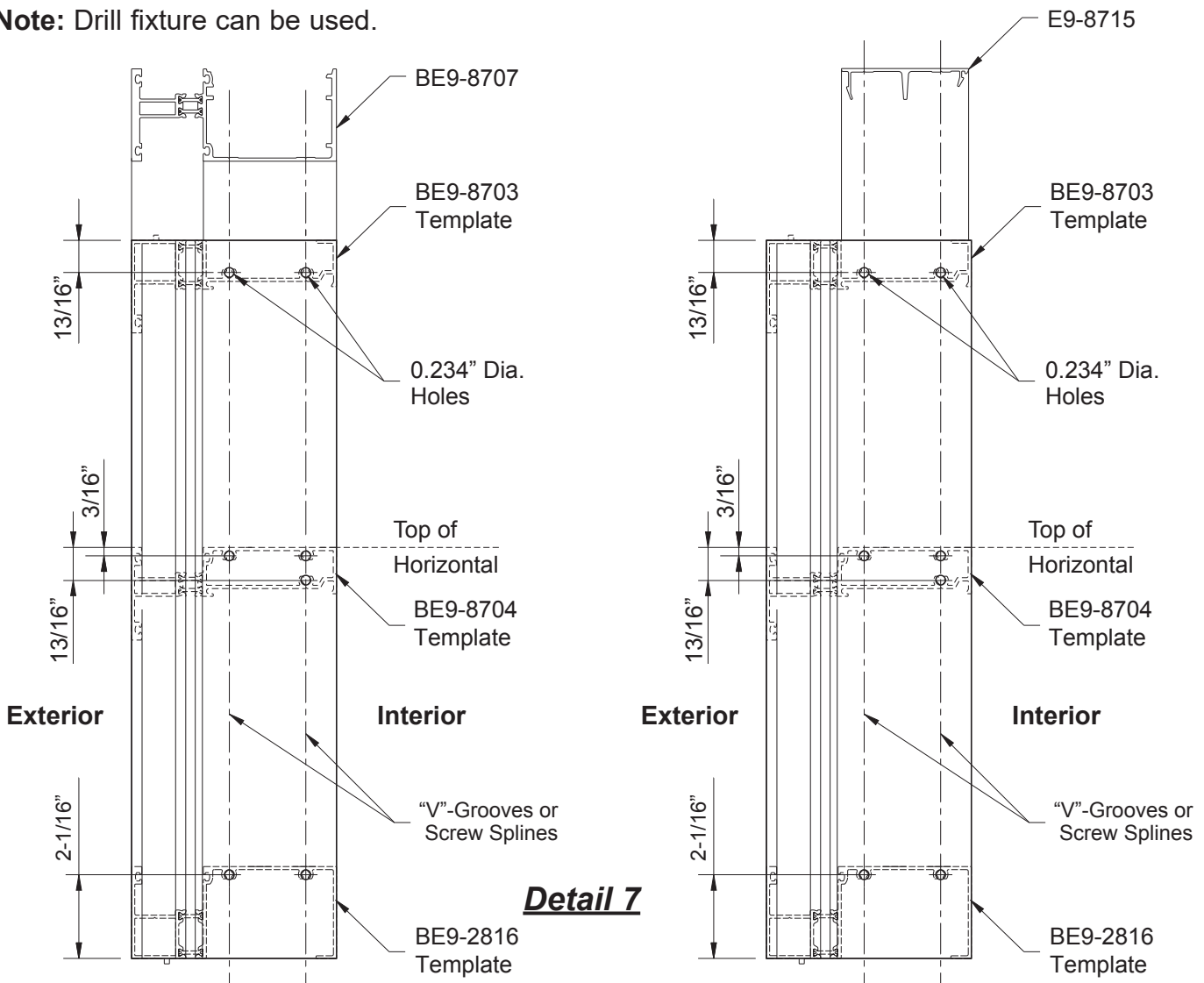

FRAME FABRICATION

STEP 4 (Continued)

FABRICATE TWO PIECE VERTICALS & JAMB MEMBERS

-Cut two piece verticals, fillers, and jamb members to the frame height determined in **Step 1** on **Page 11** or as shown on approved shop drawings.

Fabrication of Verticals for Outside Glazed Frames:

- Use a short piece of each horizontal member as a template.
- Center the template on the face of the vertical member.
- Line up the glazing pockets and mark the location of each screw spline.

**-OR-**

- Layout the hole locations along the "V"-grooves of each member as shown in **Detail 8**.
- Drill a 0.234" diameter hole at each location marked.

**Note:** Drill fixture can be used.

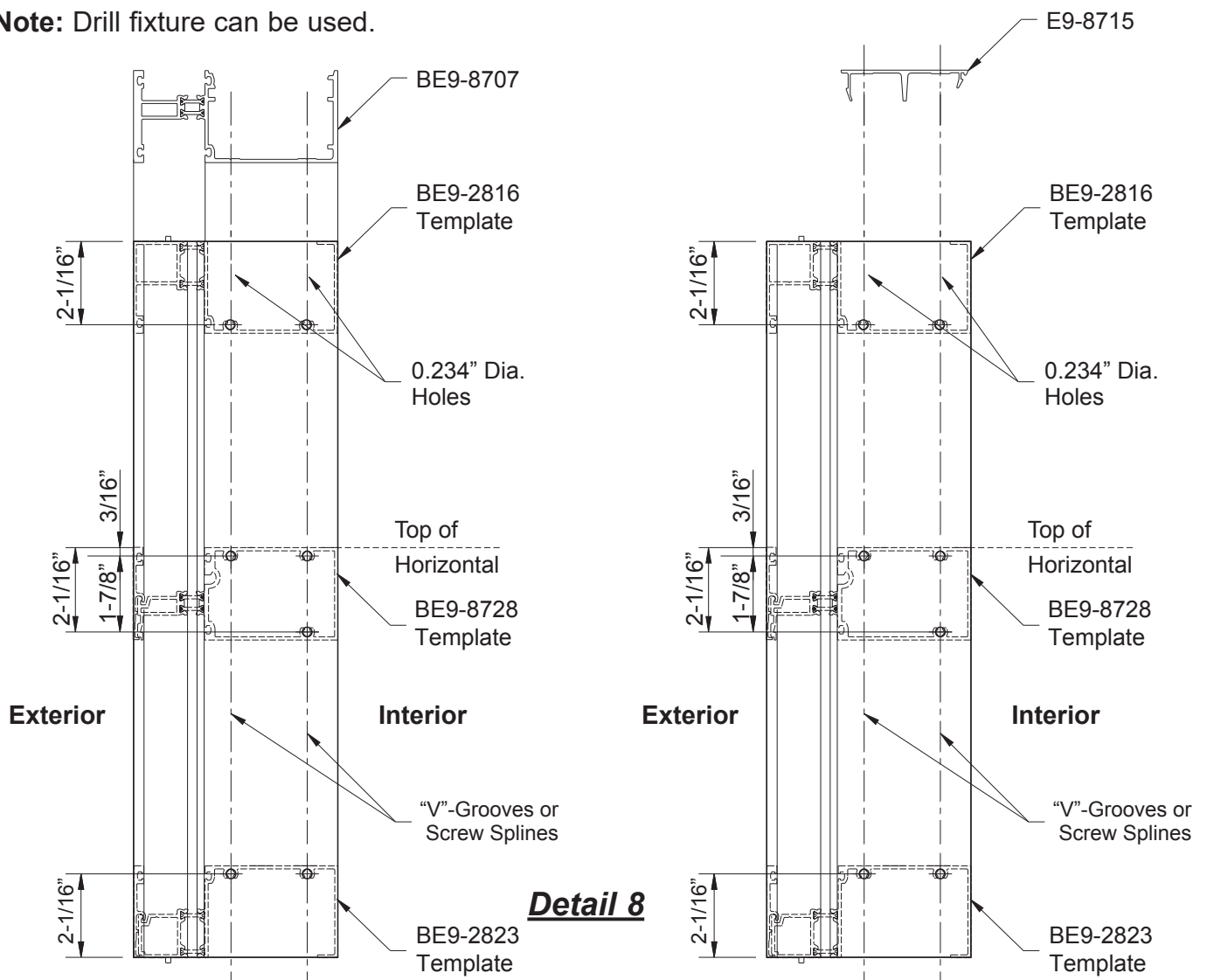

## FRAME FABRICATION

### STEP 5

#### FABRICATE INTERIOR GLASS STOP FOR INSIDE GLAZED HORIZONTALS

-Interior glazed horizontals require interior glass stops:

BE9-8704 requires interior glass stop E9-8711.

-Cut all interior glass stops to the same dimension as the horizontals (D.L.O.) minus (-) 1/32".

See **Detail 9**.

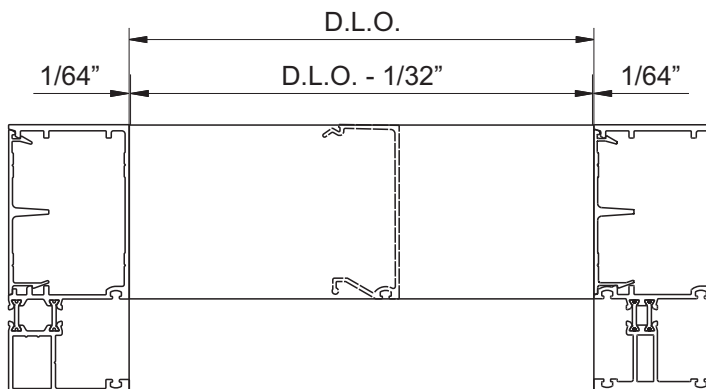

**Detail 9**

### STEP 6

#### FABRICATE EXTERIOR GLASS STOP FOR OUTSIDE GLAZED HORIZONTALS

-Exterior glazed horizontals require exterior glass stops:

BE9-8706 and BE9-8728 requires interior glass stop E9-1715.

-Cut the glass stop to the same dimension as the horizontals (D.L.O.) minus (-) 1/32".

See **Detail 10**.

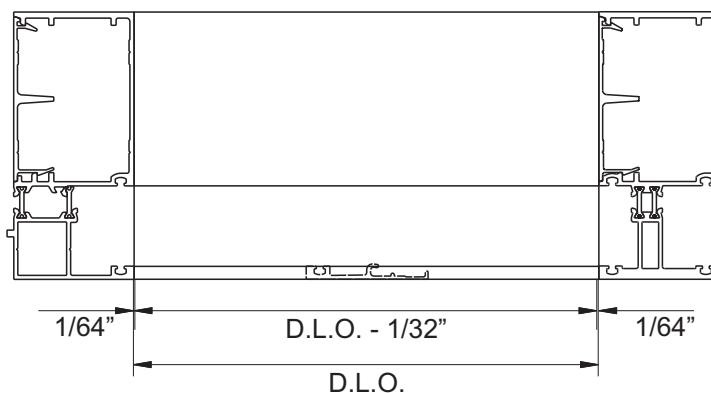

**Detail 10**

**FRAME FABRICATION**

**STEP 6 (continued)**

**FABRICATE EXTERIOR GLASS STOP FOR OUTSIDE GLAZED HORIZONTALS**

**Structural Silicone Glazing (SSG):**

- For frame widths 24'-0" or less cut the face covers to the frame width minus 4-9/16".
- For frame widths greater than 24'-0" face members are spliced every ten to fifteen feet at the center of an intermediate vertical.
- Allow for a 1/32" joint at each jamb and a 3/8" joint between face cover splices.

**Caution: DO NOT splice the face cover at an expansion mullion!**

See **Detail 10A**.

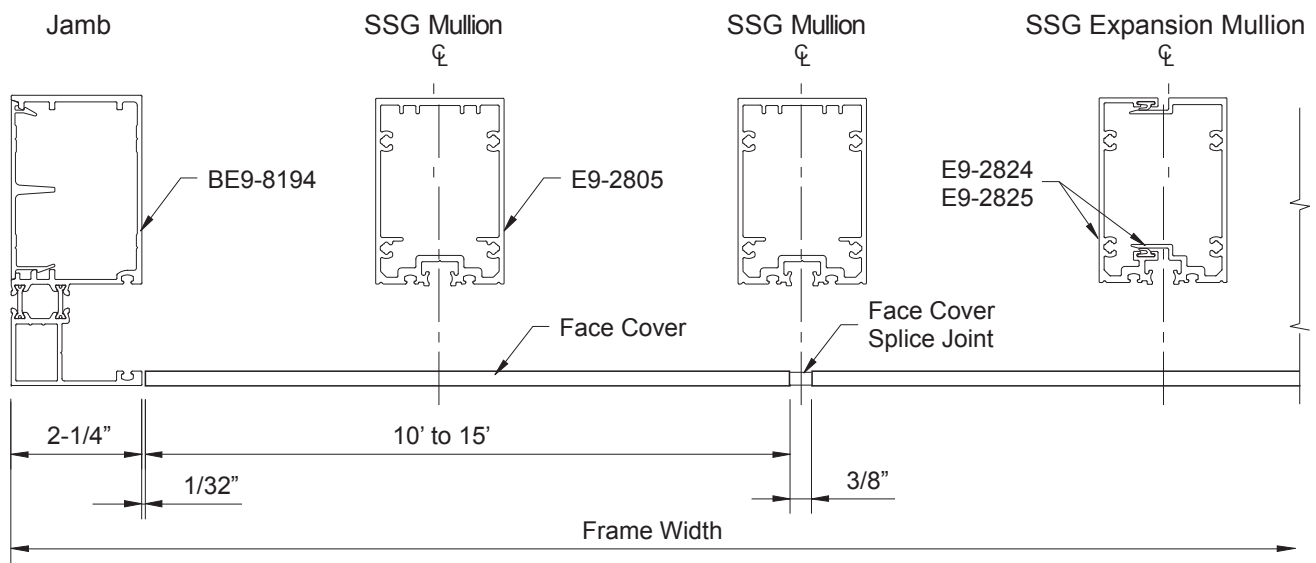

**Detail 10A**

**FRAME FABRICATION**

**STEP 6  
FABRICATE GLAZING ADAPTORS**

YWW 50 T offers glazing adaptors for 1/4" glazing:

- E9-1707 for captured mullion deep pockets.
- E9-1708 for captured mullion shallow pockets.
- E9-2716 for structural silicone glazed (SSG) vertical mullions.
- E9-1725 for BE9-8734 pocket fillers for 90° corner posts and door jambs.

- Cut vertical glazing adaptors to the daylight opening dimension between horizontals plus(+) 7/8".
- Cut horizontal glazing adaptors to the daylight opening dimension between verticals minus(-) 1/32".

Glazing adaptor, E9-2716, requires additional fabrication:

- Mark hole locations along the recessed area in the middle of the adaptor 2" from each end and 12" on center.
- Drill 0.213" (#3 bit) dia. holes at each location marked.

See **Detail 11**.

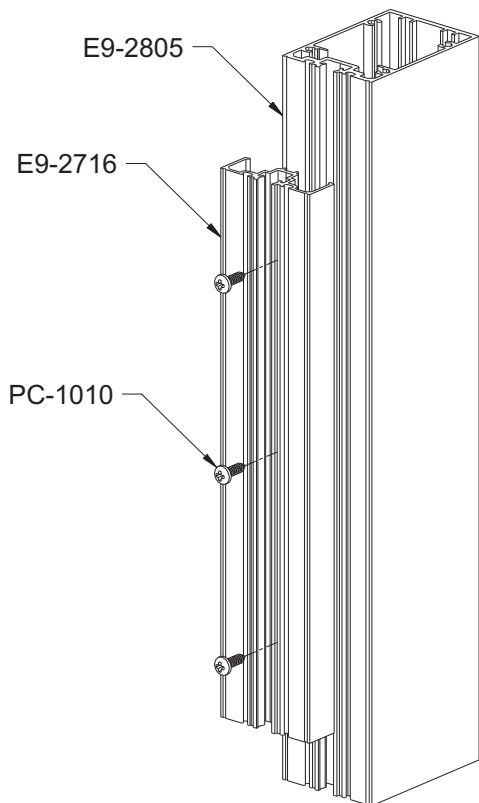

**Detail 11**

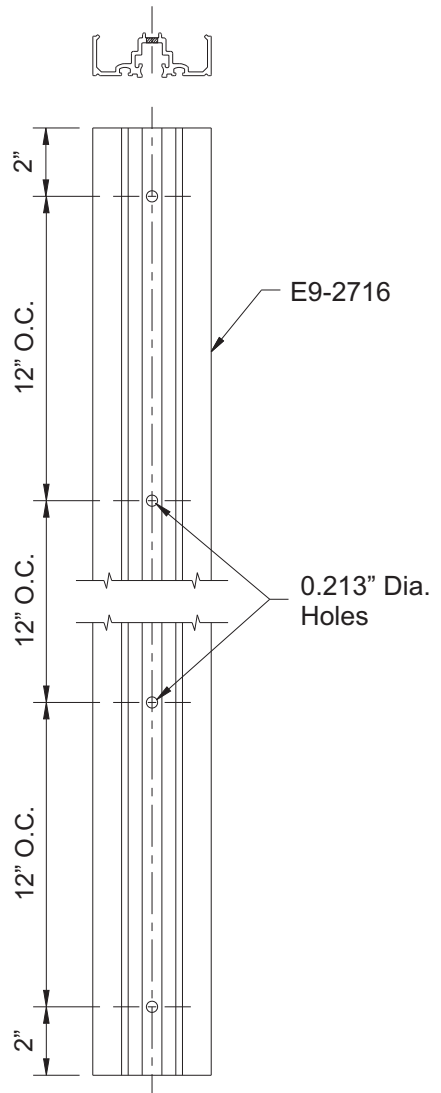

**FRAME FABRICATION**

**STEP 7**

**FABRICATE PLATE ADAPTOR**

- Cut the aluminum plate adaptor, E9-8222, to the same length as the sill flashing.
- Notch the aluminum plate adaptor 1-1/2" from each end where adjacent to a splice location as shown in **Detail 12**.

**Detail 12**

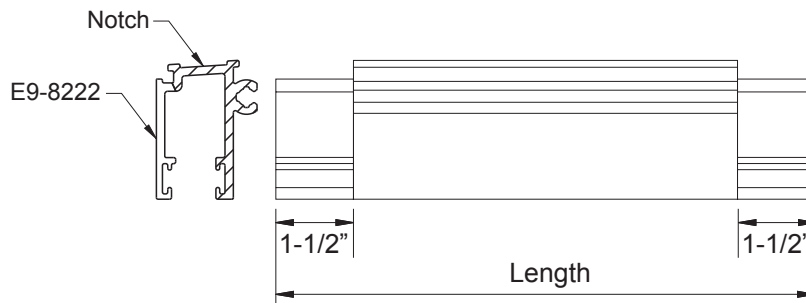

- Drill a hole at each location marked for anchoring to the sill flashing. Anchor size and location as determined by structural calculations.
- Alternate perimeter fasteners as shown with dimensions a and b.

**Note:** It is necessary to also notch the sill flashing 2-1/2" from each end where adjacent to a splice location as shown in **Detail 13**.

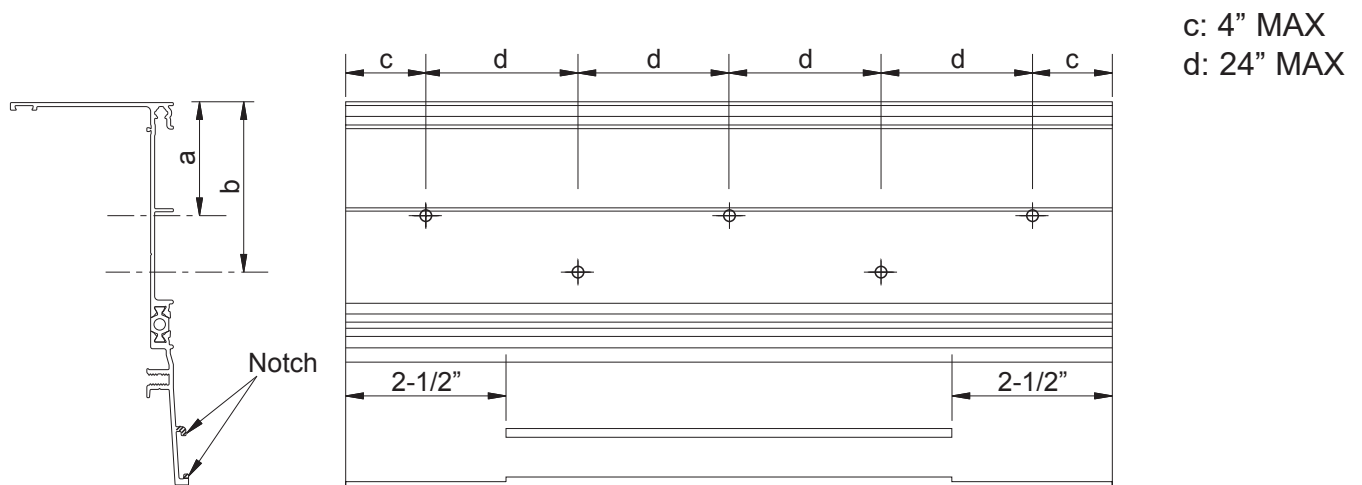

**Detail 13**

**FRAME FABRICATION**

**STEP 8**

**FABRICATE HEAD RECEPTOR AND SLAB EDGE COVER**

- Cut the head receptor and snap cover to the same dimension of the sill flashing as determined in **Step 2**.
- Alternate perimeter fasteners and drill weep holes as shown in **Detail 14**.

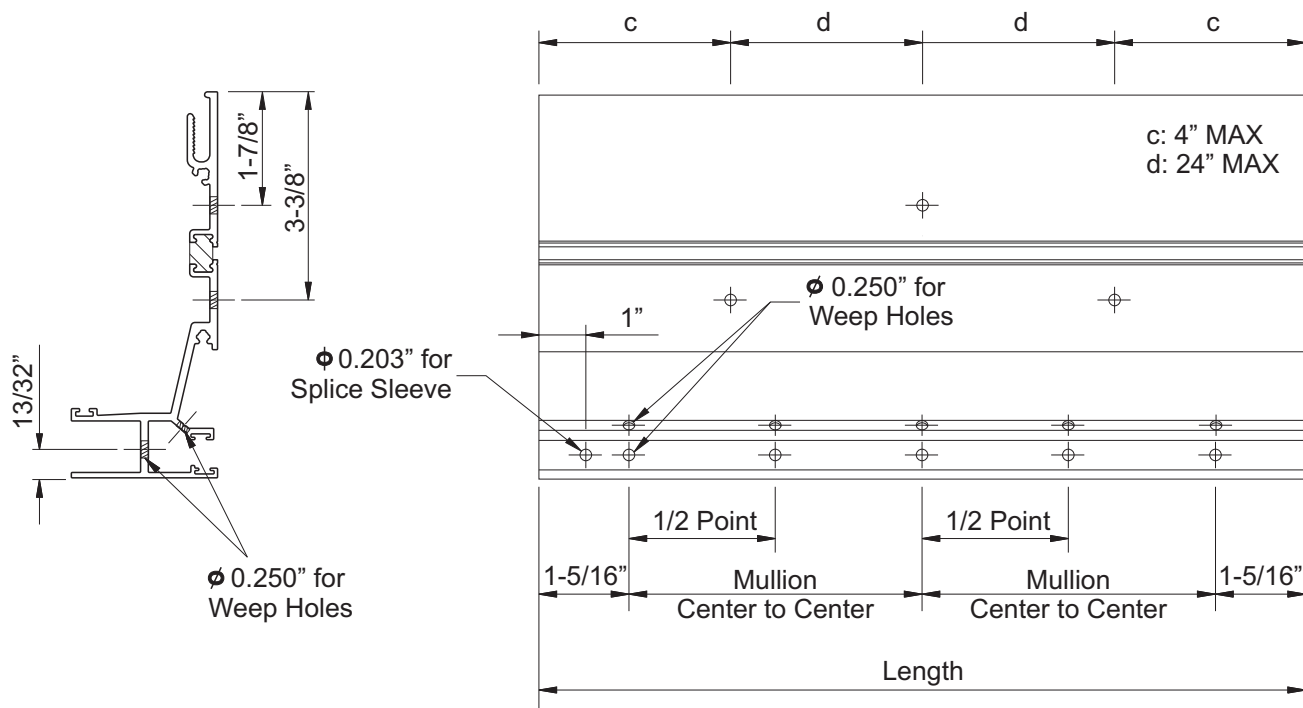

**Detail 14**

## FRAME FABRICATION

### STEP 9

### FABRICATE HEAD NEAR EXPANSION JOINT

The square nubs at the head will need to be notched at the expansion mullions to clear the end caps.

-Cut the nub 1/2" at the expansion mullion half of which the end cap is not attached to.

See **Detail 15**.

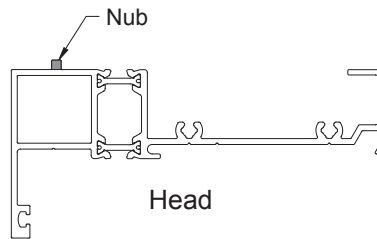

### **Detail 15**

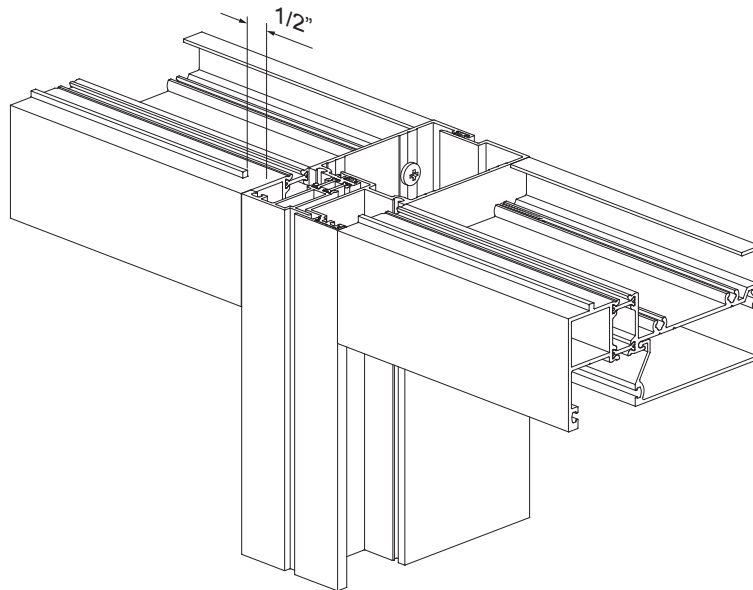

## FRAME ASSEMBLY

### STEP 10 ATTACH MULLION END CAPS

Mullion end caps are required at the top end only of jamb and vertical mullions of vertical through frames and at each end of the expansion mullion of continuous head and sill frames.

- Clean the vertical mullion ends and mullion end caps with a cleaner and method approved by the sealant manufacturer.
  - Apply sealant to the gasket reglet and along the front of the vertical members on both ends prior to installing mullion end caps .  
For expansion mullions, apply sealant to the fastener side mullion only.
  - Attach the mullion end caps to each end of the mullion with fasteners as shown **Detail 16**.
  - Install E1-2806 mullion cap as shown on expansion mullion half. On the standard mullion, install E1-2809 end cap as shown.
  - Tool the excess sealant along the inside of the glazing pocket between the mullion end cap and the mullion.
- Field note:** At the top of each mullion, the perimeter sealant must cover the extrusions entire front edge, thus completely covering the mullion cap.
- Seal all screw heads.
- See **Detail 15**.

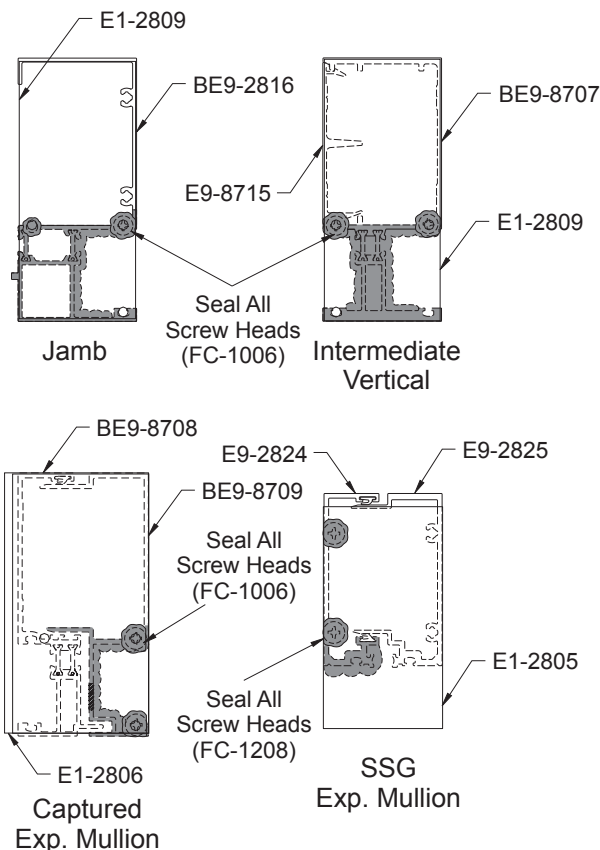

**Detail 16**

### STEP 11 INSTALL END DAMS (For Continuous Head & Sill Frames Only)

The ends of head and sill members of continuous head & sill frames must be plugged using end dams, E2-0193 and E2-0194.

Use the following technique to install end dams at the head and sill:

- Clean the ends of the head and sill members with a cleaner and method approved by sealant manufacturer.
  - Apply sealant to all contact sides of the end dam.
  - Insert the end dam into each end, leaving it 1/8" recessed from the edge of the mullion.
  - Apply sealant to the end dams and tool the sealant flush with the ends of the mullion.
- See **Detail 17** (sill shown, head similar).

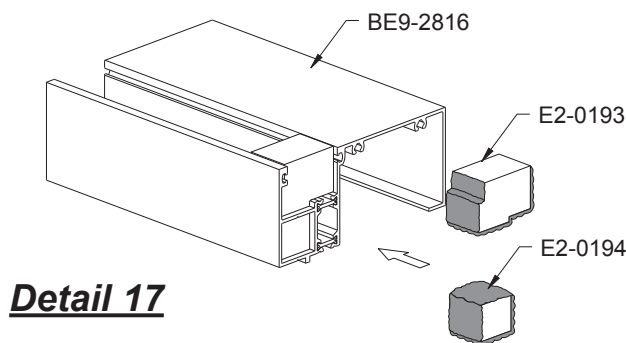

**Detail 17**

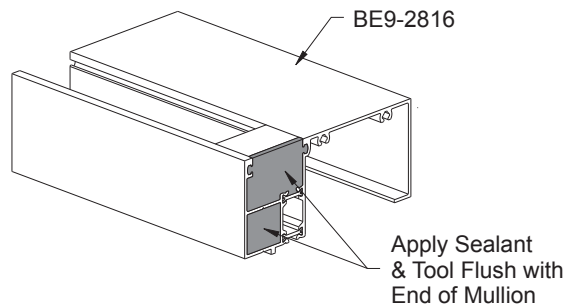

## FRAME ASSEMBLY

### STEP 12 PREPARE FRAMES FOR ASSEMBLY

#### Vertical Through Frames:

-Clean the ends of the horizontal members and attachment areas of vertical members using a cleaner approved by the sealant manufacturer.

-Apply and tool the sealant to the shaded area just prior to assembly with vertical members.

**Note:** Make sure that the sealant does not get into the glass stop reglets of the head and horizontal members.

See **Detail 18**.

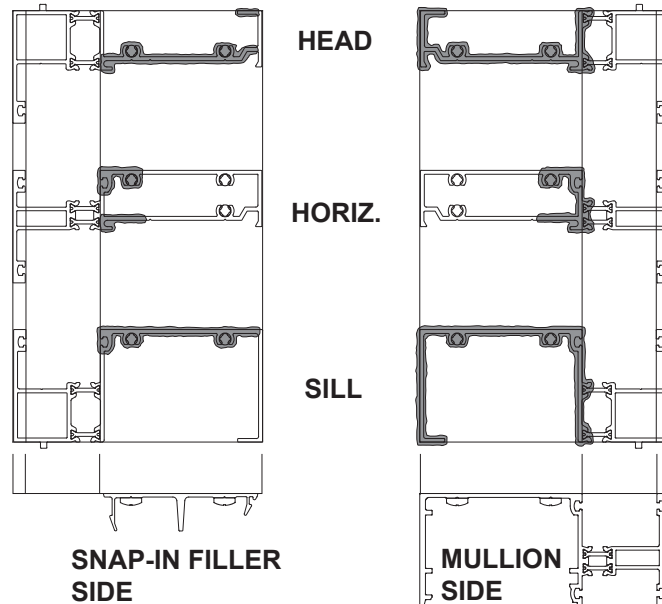

**Detail 18**

## FRAME ASSEMBLY

### STEP 12A ASSEMBLE FRAMES

#### Vertical Through Frames:

- Attach head and sill members to two piece verticals and jambs using (2) PC-1216 fasteners at each end.
- Attach intermediate horizontals to two piece verticals and jambs using (3) PC-1216 fasteners at each end.

**Note:** PC-1220 fasteners must be substituted for the PC-1216 fasteners when attaching to vertical members that have screw splines.

See **Detail 19**.  
(YWW 50 T Outside Glazed shown; others similar)

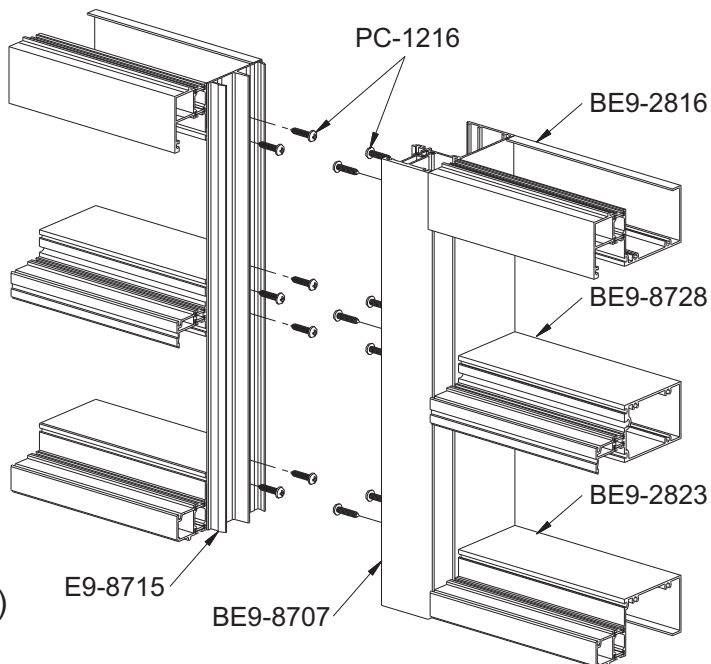

**Detail 19**

#### Continuous Head & Sill Frames With One Piece SSG Verticals:

- Attach jamb members to continuous head and sill members using (2) PC-1220 fasteners at each end.
- Attach one piece verticals to continuous head and sill members using (4) PC-1220 fasteners at each end.
- Attach intermediate horizontals to shear block, E1-2802, using (2) FC-1212 fasteners at each end.

See **Detail 20**.

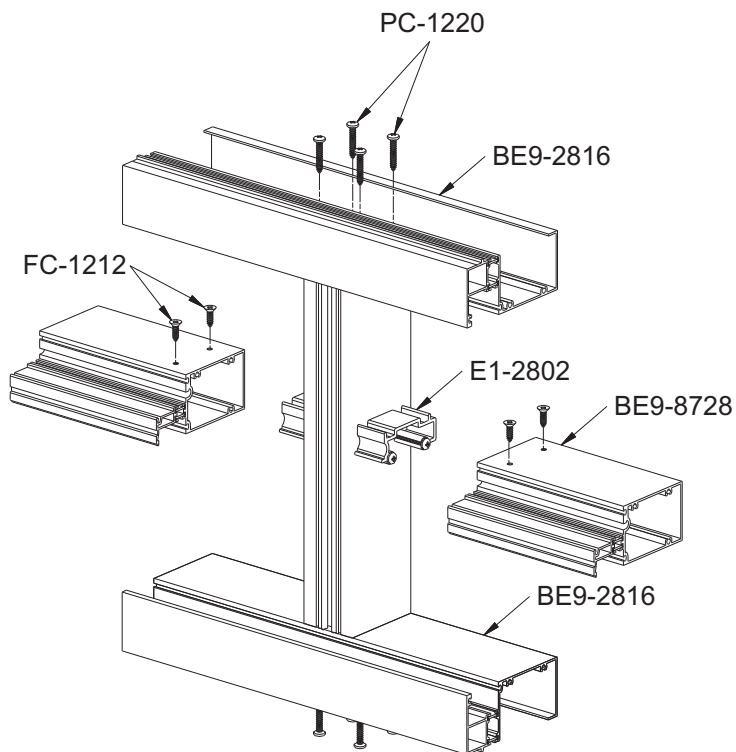

**Detail 20**

## FRAME ASSEMBLY

### STEP 13 ASSEMBLE SILL FLASHING

- Install 2 rows of gasket, E2-0065 at the slab edge cover pocket side of the plate adaptor.
- Install the aluminum plate adaptor, E9-8222 by sliding into place.

See **Detail 21**.

- For the BE9-2812 sill flashing, apply sealant to the end of the slab edge cover receptacle, and attach the E1-9951 end cap with a UA-1212 screw as shown in **Detail 21A**.

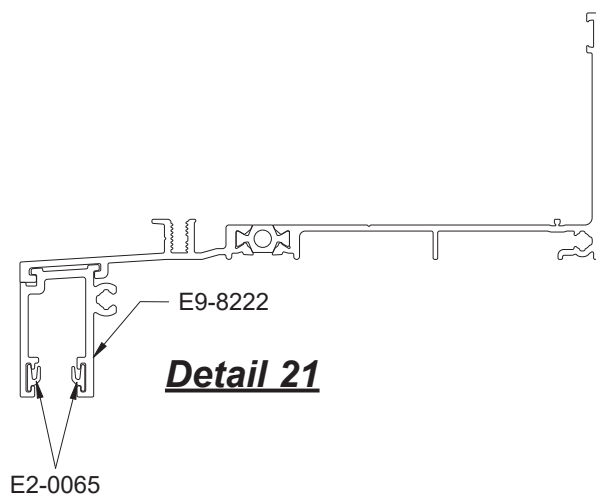

**Detail 21**

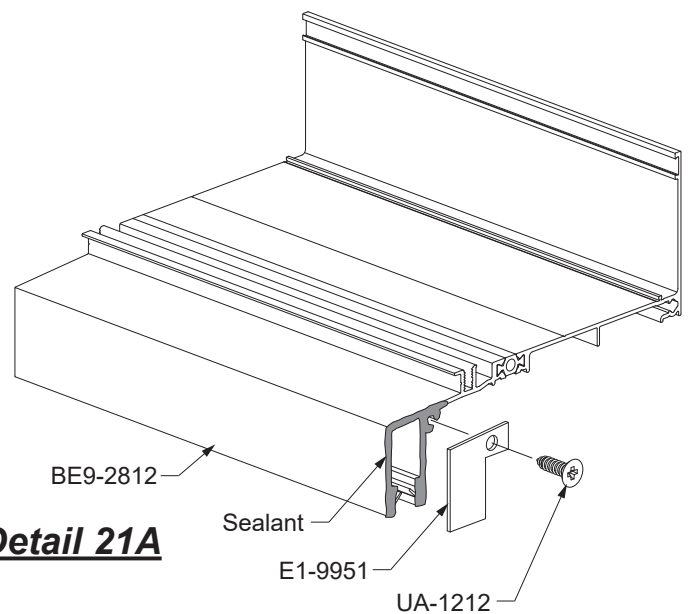

**Detail 21A**

### STEP 14 ASSEMBLE SLAB EDGE COVER

- Clean the ends of the slab edge cover and attachment areas of end caps using a cleaner approved by sealant manufacturer.
- Apply and tool sealant to each end of the slab edge cover prior to attaching the end caps.
- Attach end caps to each end of the slab edge cover using (2) UA-1212 fasteners.
- Tool and wipe away any excess sealant at the joints.

See **Detail 22**.

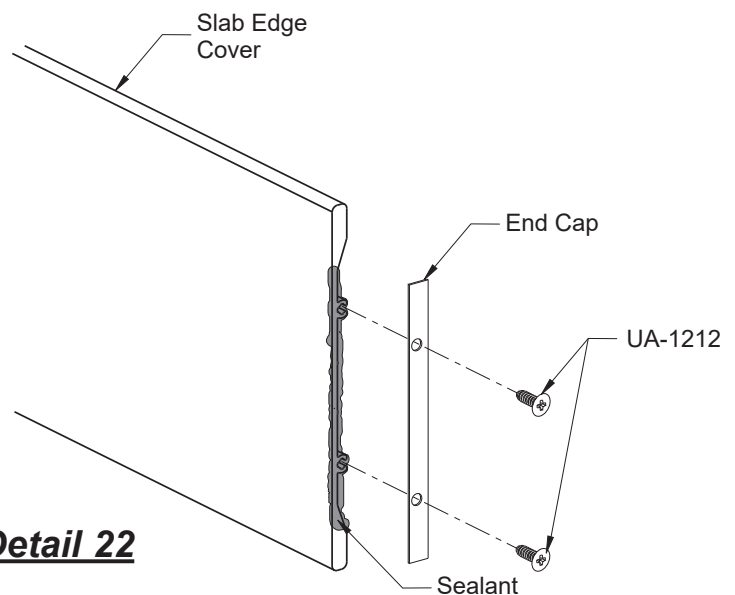

**Detail 22**

**FRAME INSTALLATION**

**STEP 15  
INSTALL SILL FLASHING END DAMS**

-Bend the tab as shown in **Detail 23** and **Detail 24** with a pair of pliers.

See **Detail 23**.

**Note:** The tab must be bent in the correct position for the left or right end of the sill flashing.

- Clean all joint surfaces using cleaner approved by sealant manufacturer.
- Apply silicone sealant to the end of the sill flashing as shown in **Detail 25**.
- Slide the tab into the top portion of the sill flashing.
- Tap the tab into place with a small tool until the end dam is snug against the end cut of the flashing.
- Fasten the end dam to the sill flashing with two UA-1212 screws, starting at the back, followed by the front as shown in **Detail 25**.
- Tool sealant along the joint between the end dam and the sill flashing as shown in **Detail 26**.
- Seal over any exposed screw threads.

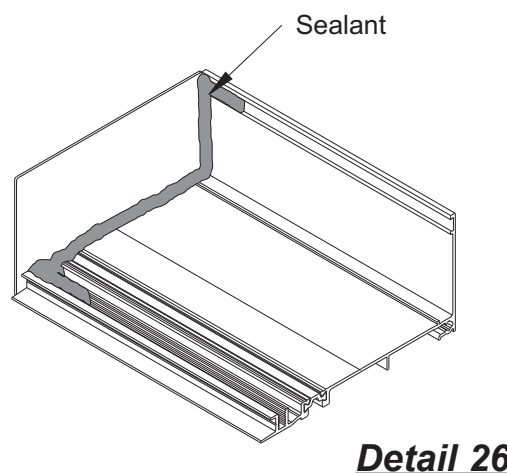
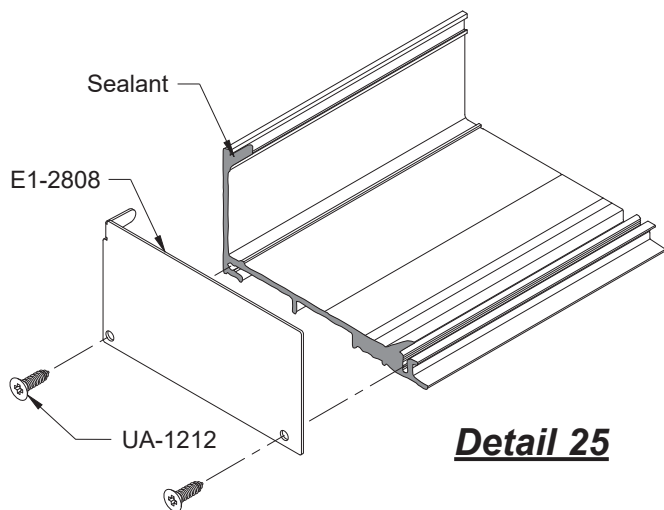
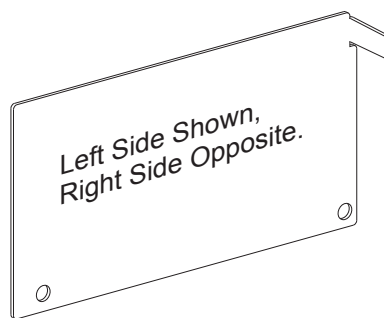
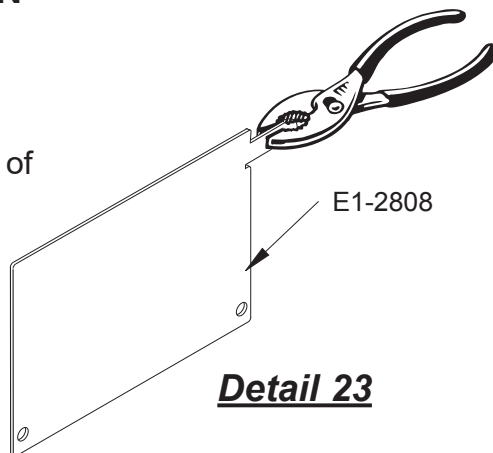

## FRAME INSTALLATION

### STEP 16 INSTALL SILL FLASHING

- Starting at the smallest opening height, install the sill flashing with a minimum of 3/8" shim underneath. Sill flashing must be installed level.
- Anchor the sill flashing to the structure a maximum of 4" from each end and then 18" to 24" on center.
- Apply and tool sealant to cover the heads of all fasteners.

### STEP 17 INSTALL SILL FLASHING SPLICE SLEEVE

- Remove the nub with a chisel or needle nose pliers a minimum length of 1 1/2" as shown in **Detail 27**.
- After the sill flashing has been shimmed and installed to the building structure, apply a small backer rod under the sill flashing as shown in **Detail 29**.
- Position the Silicone Splice Sleeve against the back wall below the groove.
- Bend the Silicone Splice Sleeve into the front on the channel as shown. Mark, and cut the sleeve at this position.
- Clean Sill Flashing and Silicone Splice Sleeve with isopropyl alcohol at the splice location
- Seal the flashing at the splice location as shown in **Detail 28**, before positioning the flashing. Set the Silicone Splice Sleeve into the sealant and flashing.
- Tool sealant tight as shown in **Detail 29**, squeezing the sheet flat.
- Thoroughly seal the small joint directly in front of the Silicone Splice Sleeve as shown in **Detail 29**.

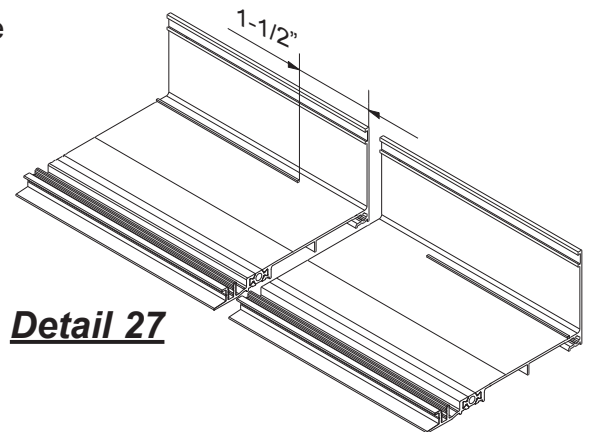

**Detail 27**

When using E2-0070, a compatible Silicone Sealant must be used at the splice. Compatible Silicone Sealants include Tremco Spectrum 2 and Dow Corning 795.

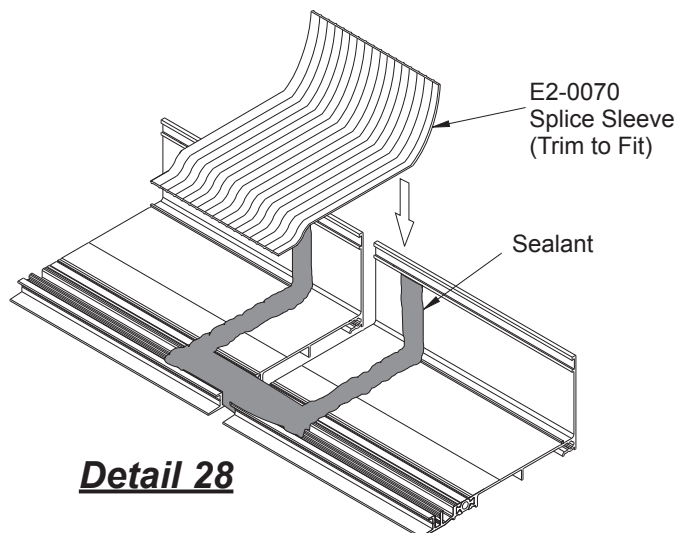

**Detail 28**

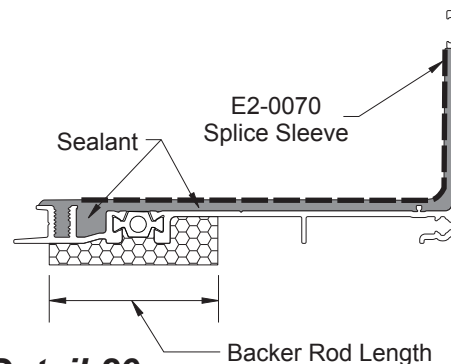

**Detail 29**

**FRAME INSTALLATION**

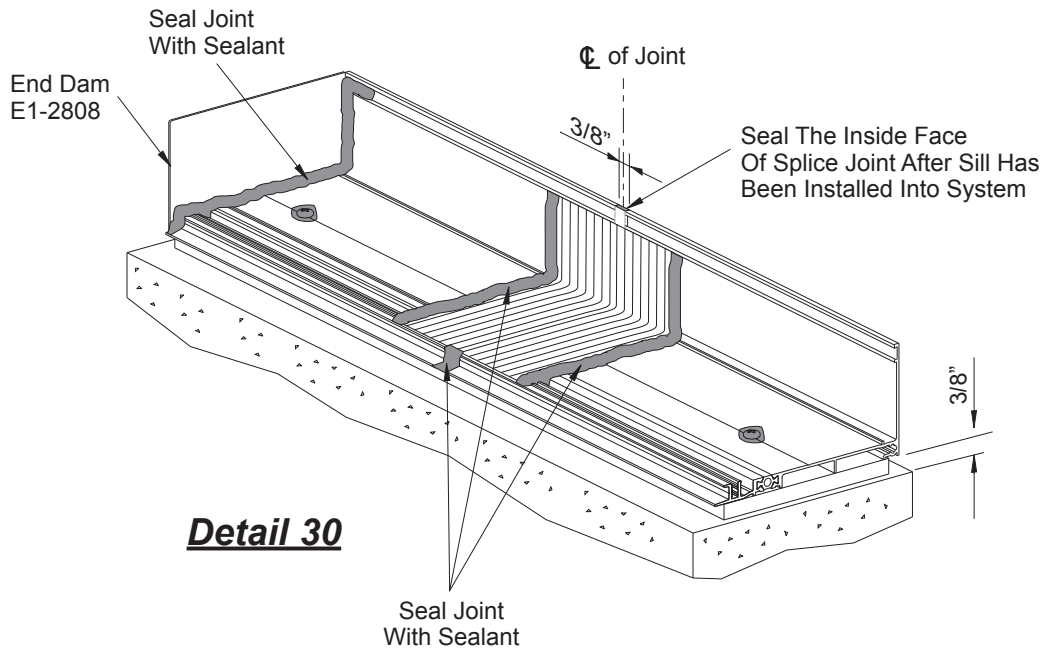

**STEP 18  
SILL FABRICATION**

At every splice condition, apply bond breaker tape to the back of the sill member before it is placed into the sill flashing. See **Detail 31**.

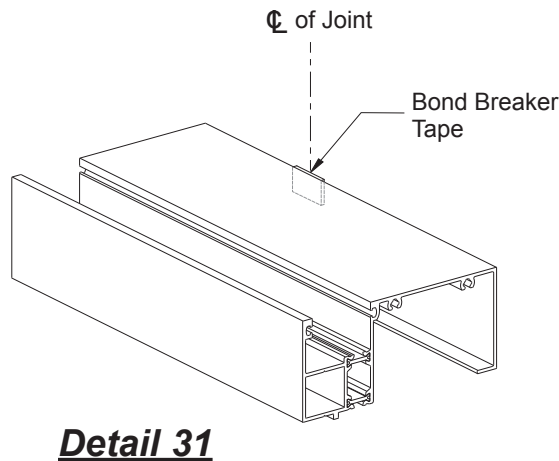

FRAME INSTALLATION

STEP 19

INSTALL CORNER MULLIONS FOR VERTICAL THROUGH FRAMES

90° & 135° corner mullions and hinged mullions are available for vertical through frames only.

Install sill flashing at corners:

- Cut two 12" long pieces of sill flashing and miter (45° for 90° corners and 67.5° for 135° corners).
  - Align the two pieces at the corner condition with the mitered ends pushed together tight and anchor the sill flashing as called out on shop drawings.
  - Apply and tool sealant to the mitered joint and anchor heads.
- See **Detail 32**.
- Continue installing the rest of the sill flashing providing a 3/8" expansion joint at splices as shown in **Step 16 on Page 29 & 30**.

**Detail 32**  
90° Outside Corner Shown  
Others Similar

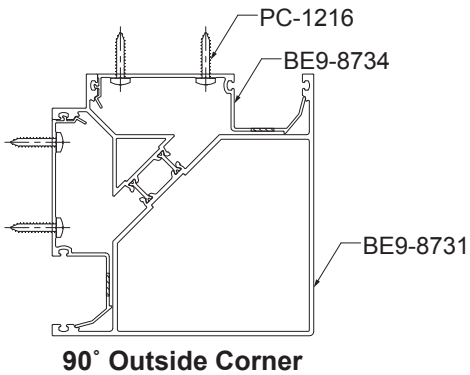
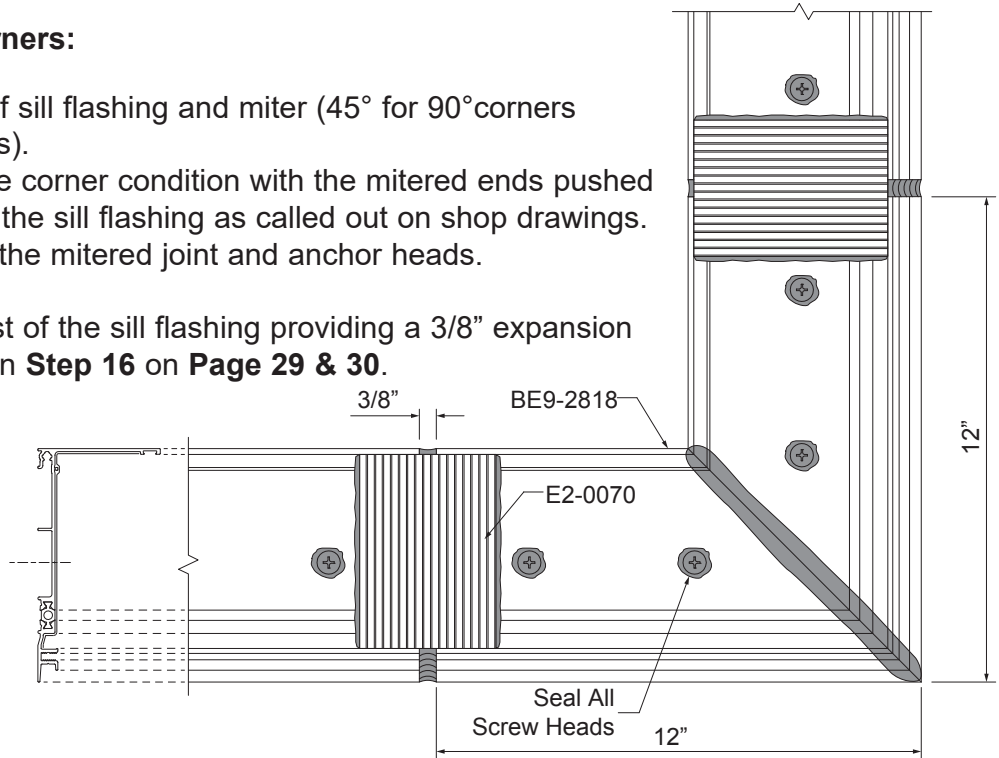

**Detail 33**

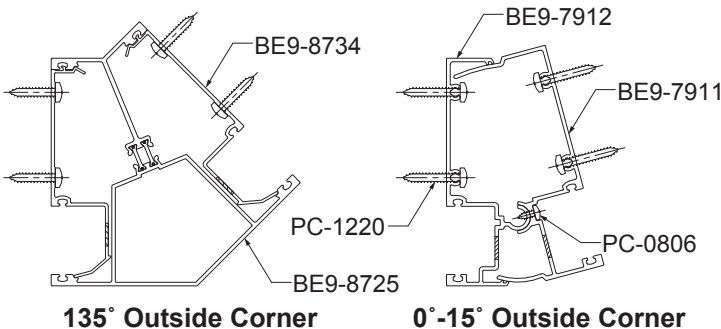

Install Corner Assemblies:

- Attach horizontal members to standard verticals as shown before in **Step 11**.
  - Attach the other end of the horizontals to the corner mullions, hinged mullions or flat fillers, corners using the same technique.
  - Snap the corner framing members together to form the corner assemblies.
  - Hinged mullions must be fastened through the ball joint 6" from each end and no more than 18" on center with PC-0806 fasteners.
  - Carefully move the corner assembly into place and snap it into the rest of the frame one side at a time.
- See **Detail 33**.

## FRAME INSTALLATION

### STEP 20 ASSEMBLE HEAD RECEPTOR

- Install setting blocks at 1/4 points of head receptor.
- Install weep baffle, E2-0099, over every weep hole location.
- Install gasket, E2-0051, on YWW 50 T frame side of receptor.
- Install two rows of gasket, E2-0065, on the slab edge cover pocket side of head receptor.
- Install reinforcement, E1-2812, as determined by engineering calculations.

See **Detail 34**.

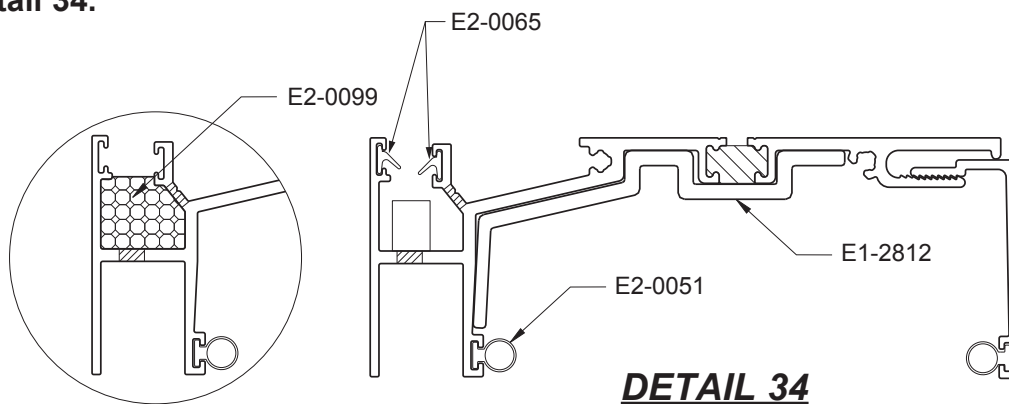

- Clean splice sleeve surfaces using cleaner approved by sealant manufacturer.
- Install splice sleeve, E2-0070, or E1-9961 in a bed of sealant at every splice joint.
- Apply and tool the sealant to the shaded area just prior to installing the end cap.
- Install end cap, E1-9957, at both receptor ends using PC-1208.

See **Detail 35**.

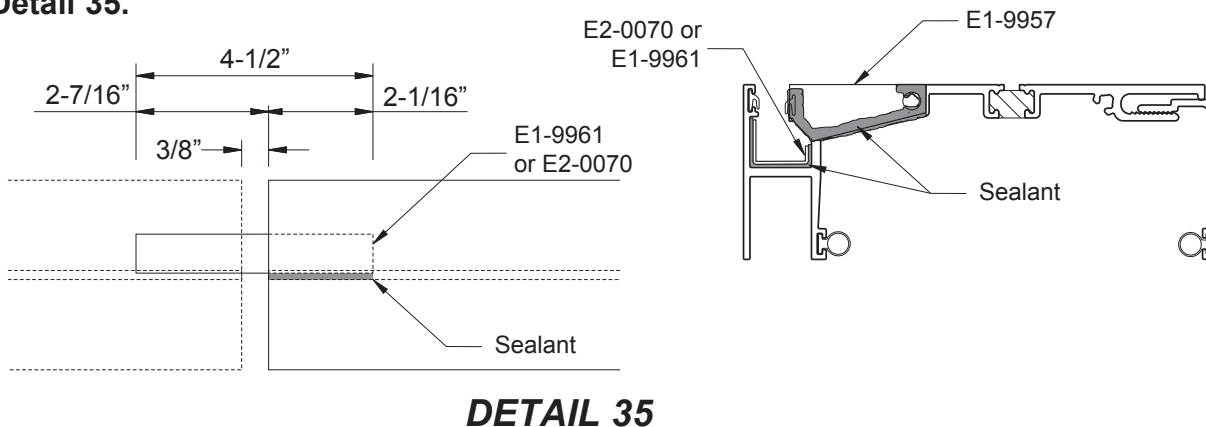

## FRAME INSTALLATION

### STEP 21 INSTALL HEAD RECEPTOR

- Clean all joint surfaces using cleaner approved by sealant manufacturer.
  - Install brake metal end cap, E1-9952, at each jamb end of the head receptor with two (2) UA-1212 fasteners.
  - Apply and tool sealant along the joint between the end cap and the head receptor.
  - Tape down the back corners to hold the end cap in place until the sealant cures.
- See **Detail 36**.

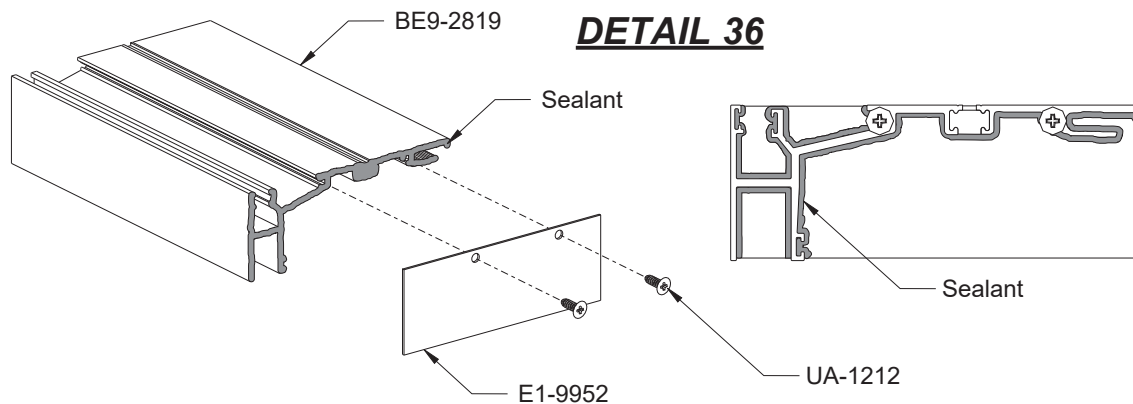

- Starting at the smallest opening height, install the head receptor with a minimum of 3/8" shim underneath. Head receptor must be installed level.
- Anchor the head receptor to the structure a maximum of 4" from each end and then 18" to 24" on center.
- Apply and tool sealant to the heads of all fasteners.
- The head receptor must be spliced every twelve to fifteen feet using splice sleeve, E1-2813:
- Apply bond breaker tape to center of the splice sleeve on the underside.
- Apply a generous amount of sealant to both sides of the head receptor splice.
- Center the splice sleeve over the 3/8" splice joint.
- Tool the sealant up and over the edges of the splice sleeve to completely seal the joint.
- Apply and tool the sealant at the front and back faces of the splice joint.
- Install splice sleeve, E1-9962, using screw, PC-1006-SS .

See **Detail 37**.

**FRAME INSTALLATION**

**STEP 22 (Continued)  
INSTALL HEAD RECEPTOR**

Shown upside down for  
viewing purposes only.

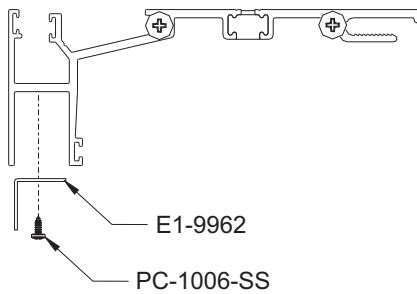
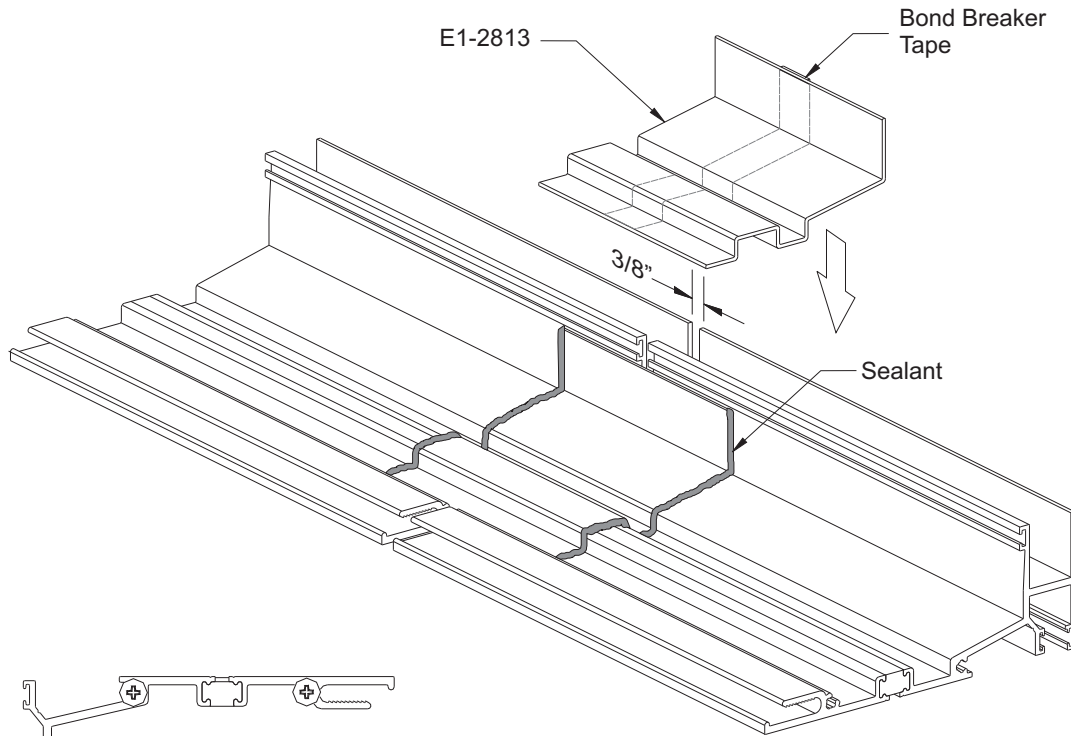

**DETAIL 37**

FRAME INSTALLATION

STEP 22  
INSTALL SLAB EDGE COVER FASCIA

-Push slab edge cover into the head receptor to make contact with setting blocks, E2-0054.

See **Detail 38**.

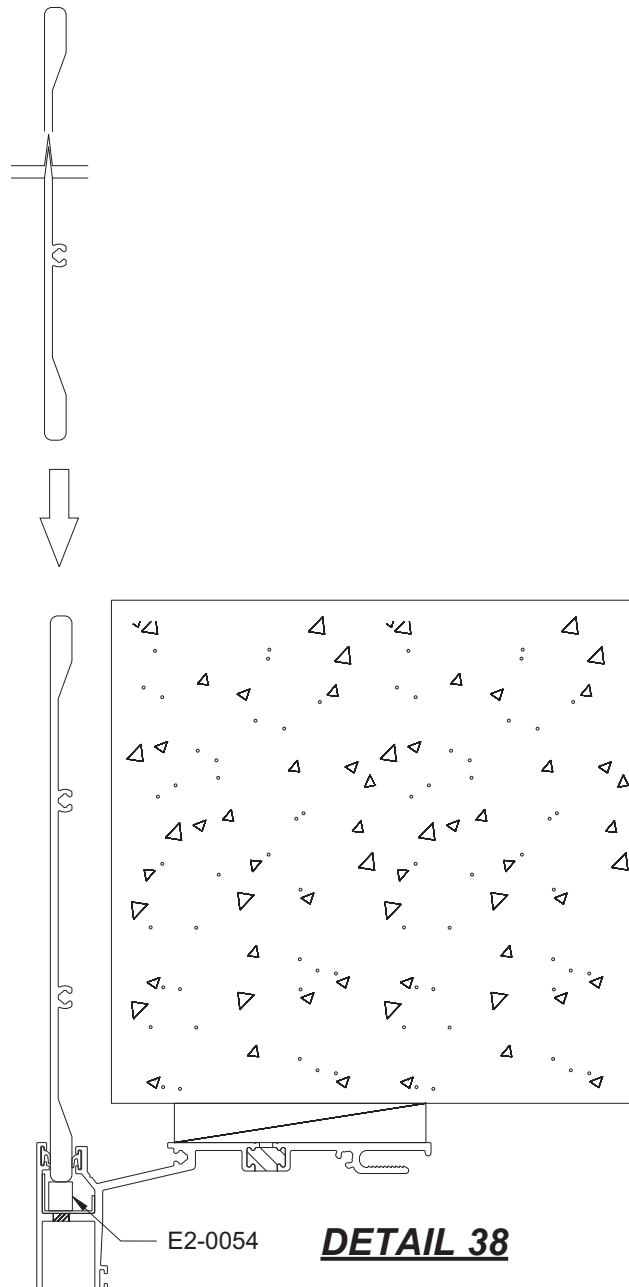

**FRAME INSTALLATION**

**STEP 23  
INSTALL SILL FLASHING END DAMS**

-Bend the tab as shown in **Detail 39** and **Detail 40** with a pair of pliers.

**Note:** The tab must be bent in the correct position for the left or right end of the sill flashing.

-Clean all joint surfaces using cleaner approved by sealant manufacturer.

-Apply silicone sealant to the end of the sill flashing as shown in **Detail 40**.

-Slide the tab into the top portion of the sill flashing.

-Tap the tab into place with a small tool until the end dam is snug against the end cut of the flashing.

-Fasten the end dam to the sill flashing with two UA-1212 screws, starting at the back, followed by the front as shown in **Detail 41**.

-Tool sealant along the joint between the end dam and the sill flashing as shown in **Detail 42**.

-Seal over any exposed screw threads.

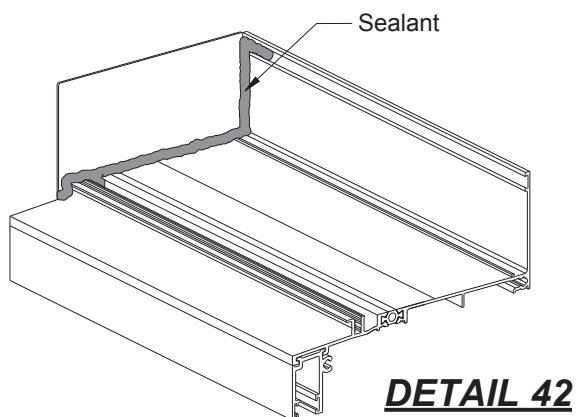
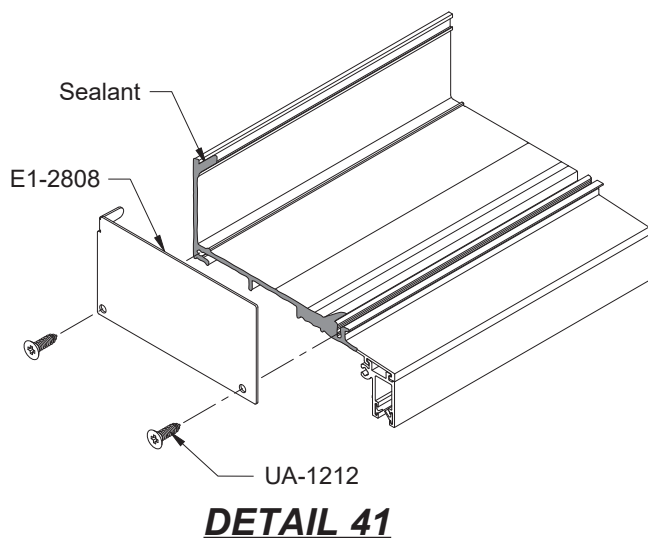
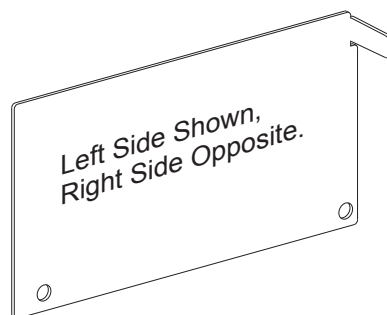
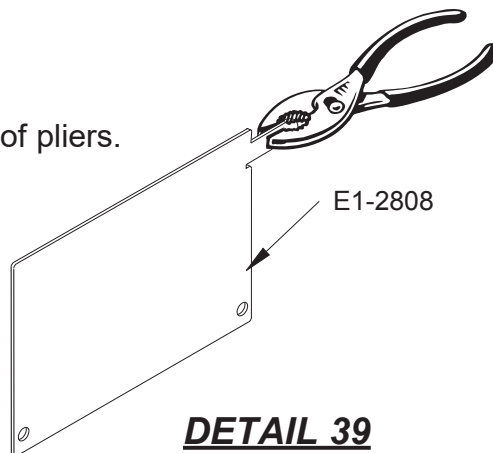

## FRAME INSTALLATION

### STEP 24 INSTALL SILL FLASHING SPLICE SLEEVE

- Apply backer tape to topside of splice sleeve.
- Apply sealant to one-half of splice sleeve topside.
- Press sealed half up into sill flashing.

See **Detail 43**.

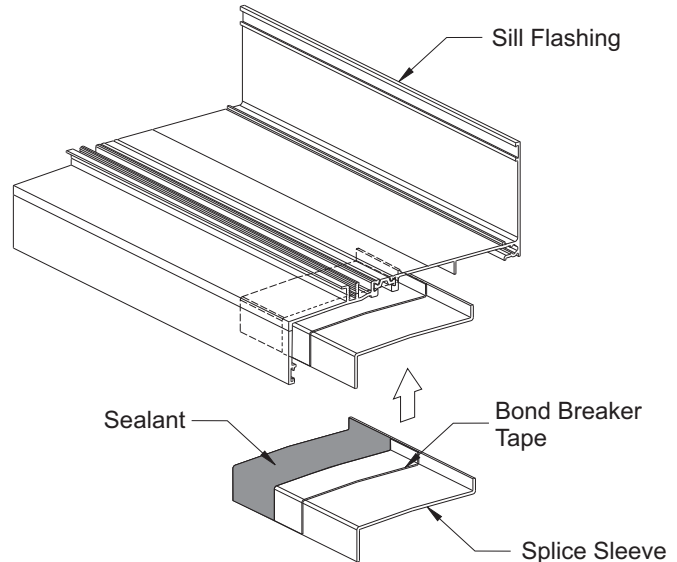

**DETAIL 43**

- Apply sealant to remaining exposed sill flashing.
- Lower the second half of sill flashing onto splice sleeve as shown in **Detail 44**.
- Be sure to leave a 3/8" joint as shown in **Detail 44**.

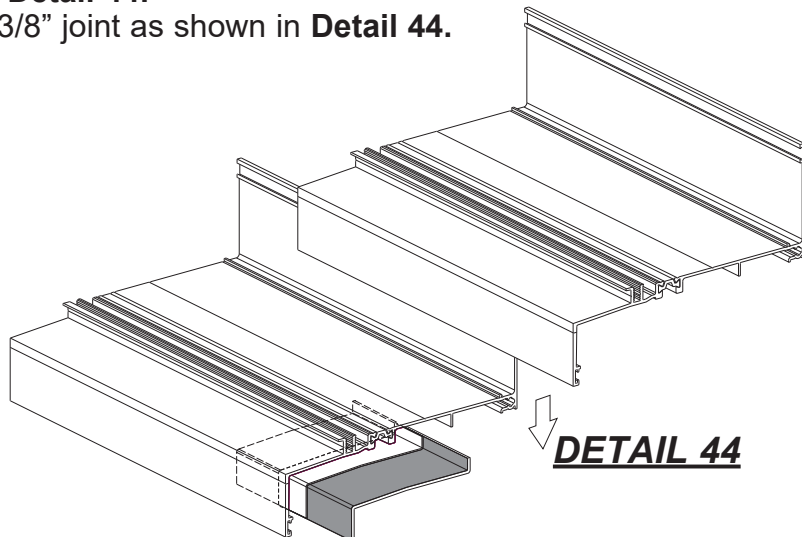

**FRAME INSTALLATION**

**STEP 25  
INSTALL SILL FLASHING SPLICE SLEEVE**

- Remove the nub with a chisel or needle nose pliers a minimum length of 1-1/2" as shown in **Detail 45**.
- Apply sealant to topside of Splice Sleeve as shown in **Detail 45**.
- Position the Silicone Splice Sleeve against the back wall below the groove.
- Bend the Silicone Splice Sleeve into the front on the channel as shown. Mark, and cut the sleeve at this position.
- Clean Sill Flashing and Silicone Splice Sleeve with iso-propyl alcohol at the splice location
- Seal the flashing at the splice location as shown in **Detail 46**, before positioning the flashing. Set the Silicone Splice Sleeve into the Sill Flashing.
- Tool sealant tight as shown in **Detail 46**, squeezing the sheet flat.
- Thoroughly seal the small joint directly in front of the Silicone Splice Sleeve as shown in **Detail 47** on **Page 39**.

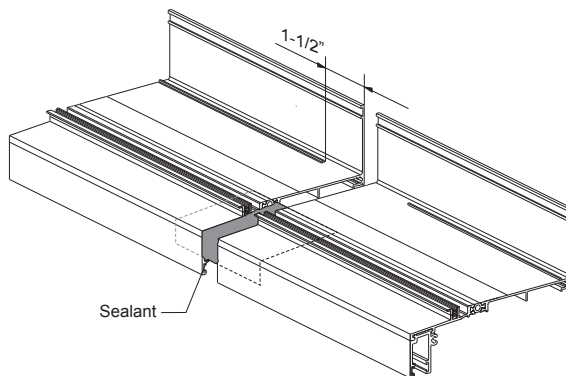

**Detail 45**

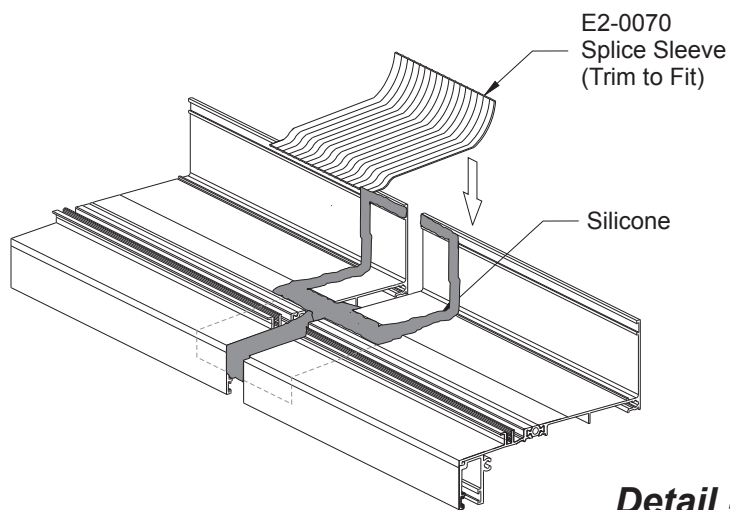
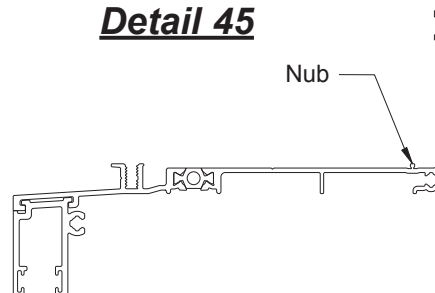

**Detail 46**

When using E2-0070, a compatible Silicone Sealant must be used at the splice. Compatible Silicone Sealants include Tremco Spectrum 2 and Dow Corning 795.

FRAME INSTALLATION

STEP 25 (Continued)  
INSTALL SILL FLASHING SPLICE SLEEVE

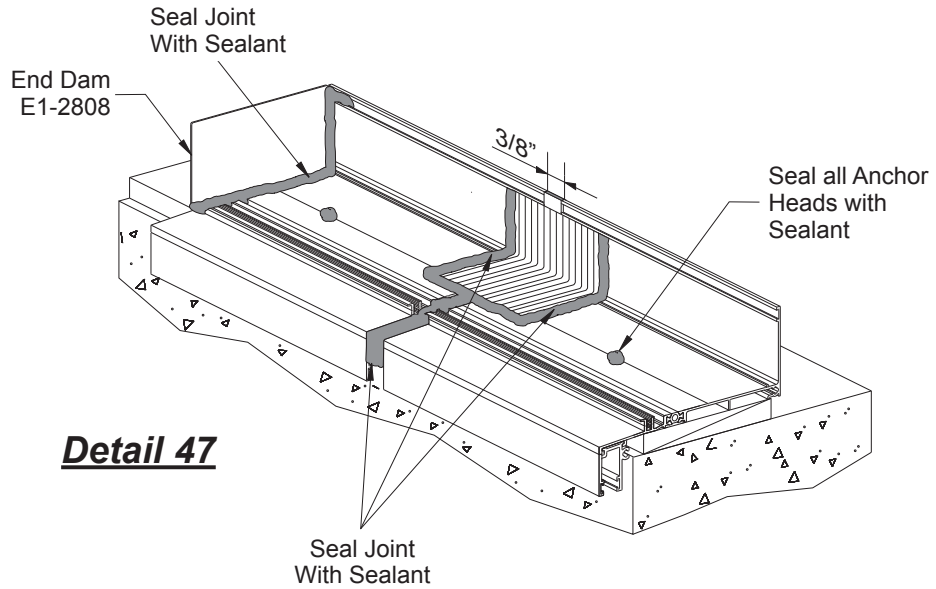

## FRAME INSTALLATION

### STEP 26 INSTALL ASSEMBLED FRAMES

- Immediately before installing the frames, apply a continuous bead of sealant to the top of the upturned leg of the sill flashing, and a generous amount of sealant to the pilot holes in the sill flashing. Be sure not to obstruct weep holes on exterior of sill. Make sure all surfaces are clean before applying sealant.
- Snap frame assemblies together and set onto the sill flashing.
- Shim the head and jamb members to ensure that the frame is installed plumb, square, and true.
- Anchor the head members at 6" on each side of every vertical centerline and then no more than 24" on center.
- Anchor jamb members 6" from each end and then no more than 24" on center.
- Follow by inserting and tightening fasteners into flashing through sealant.
- Seal all anchor heads.

**Note:** Shims must be installed at all anchor locations.

See **Detail 48**.

(Inside glazed shown, outside glazed similar)

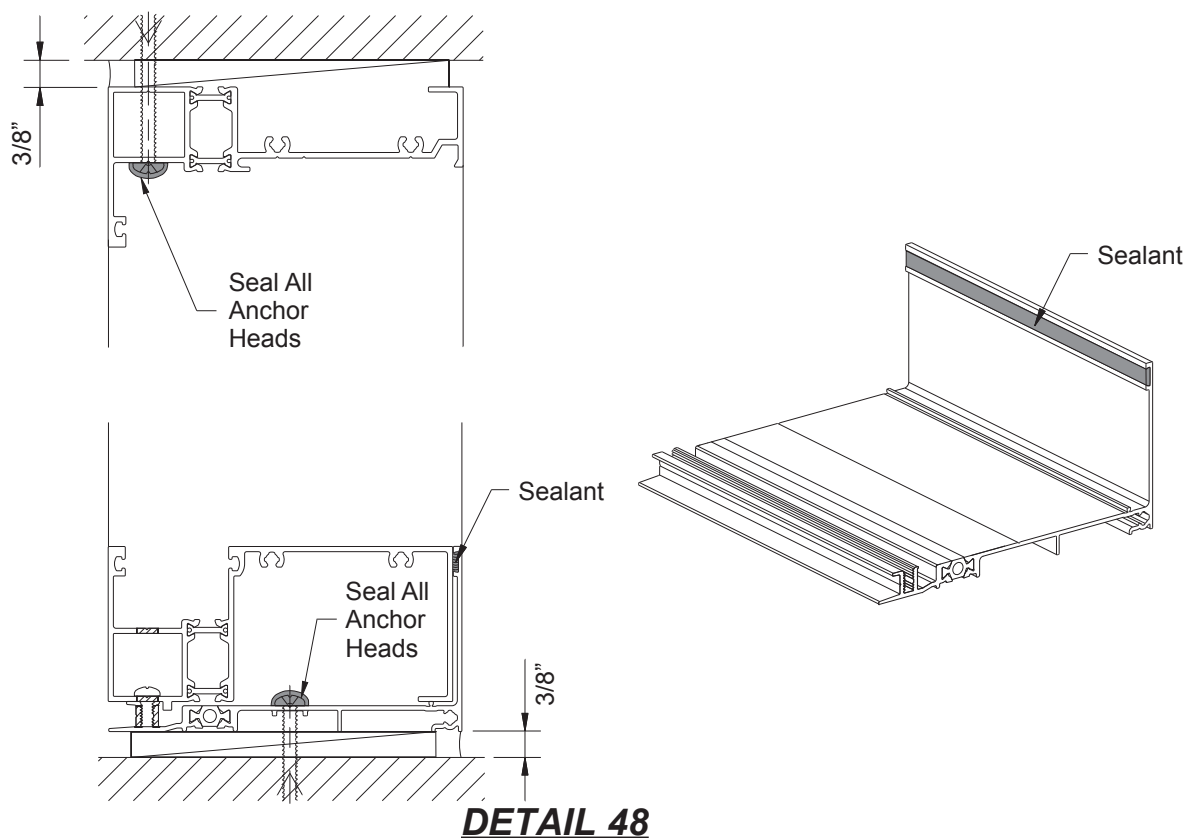

## FRAME INSTALLATION

### STEP 26A INSTALL ASSEMBLED FRAMES

-Clean the ends of horizontal members and attachment areas of the vertical members using a cleaner approved by the sealant manufacturer.

-Apply and tool the sealant to the shaded area just prior to the mullion snap-in. Make sure that the sealant does not get into the glass stop reglets of the head, horizontal, and sill.

-Snap the mullion filler into the mullion.

-Tool and wipe away any excess sealant at the joints

See **Detail 49**.

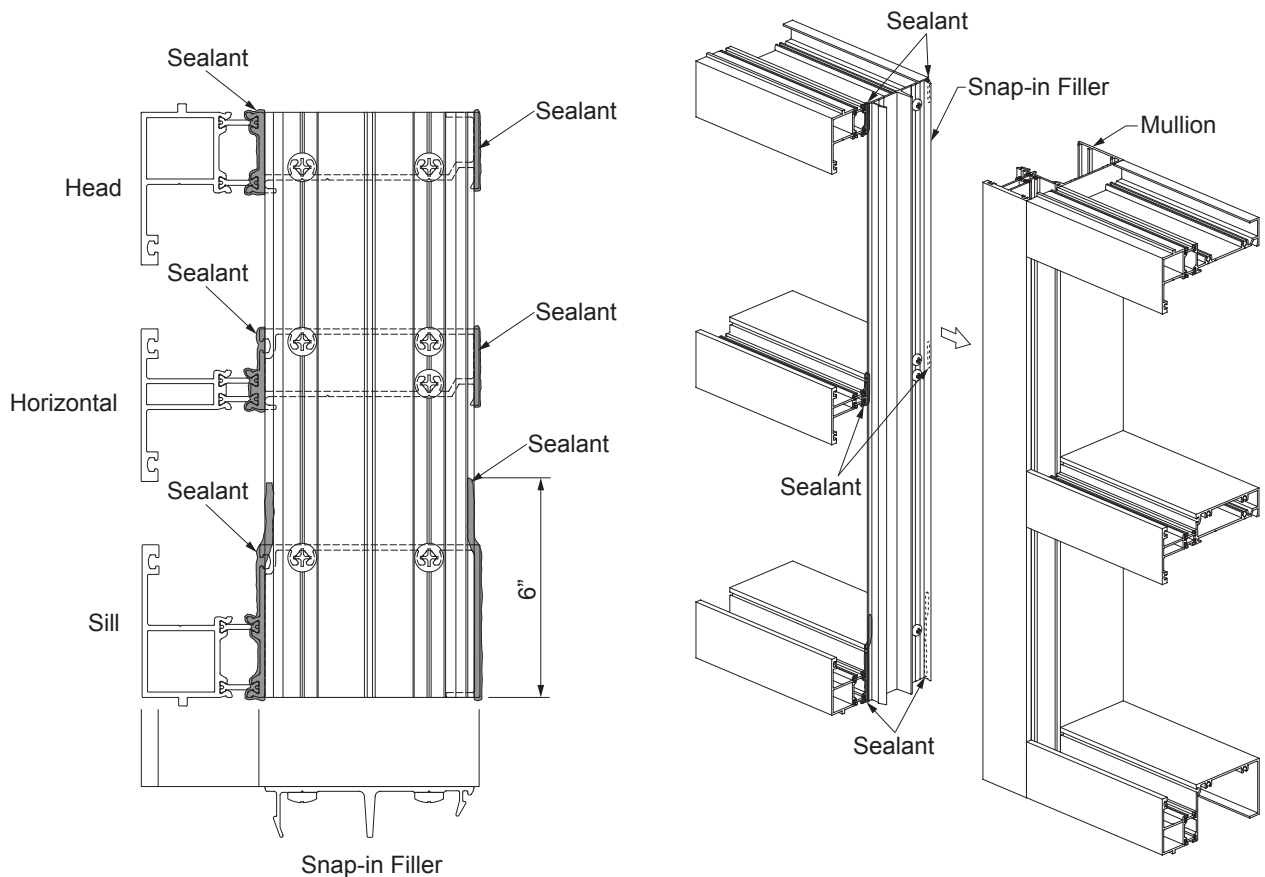

**DETAIL 49**

**FRAME INSTALLATION**

**STEP 27**

**APPLY INTERNAL & PERIMETER SEALANT**

-Apply sealant to all vertical/horizontal joints at the glazing pockets.

-Tool the sealant to ensure a watertight joint.

See **Detail 50**.

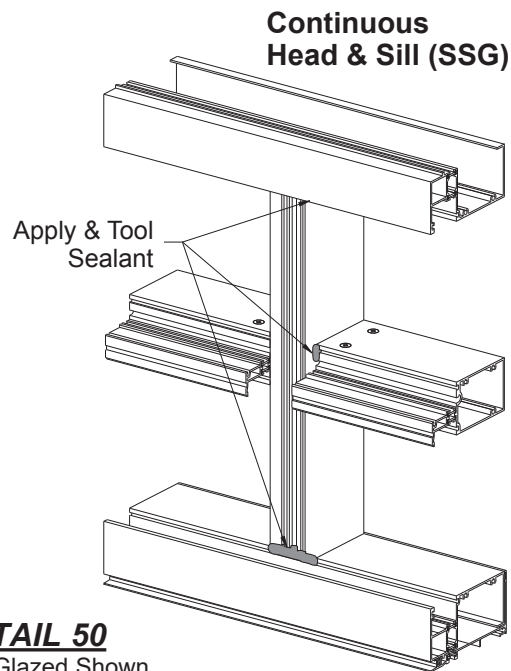
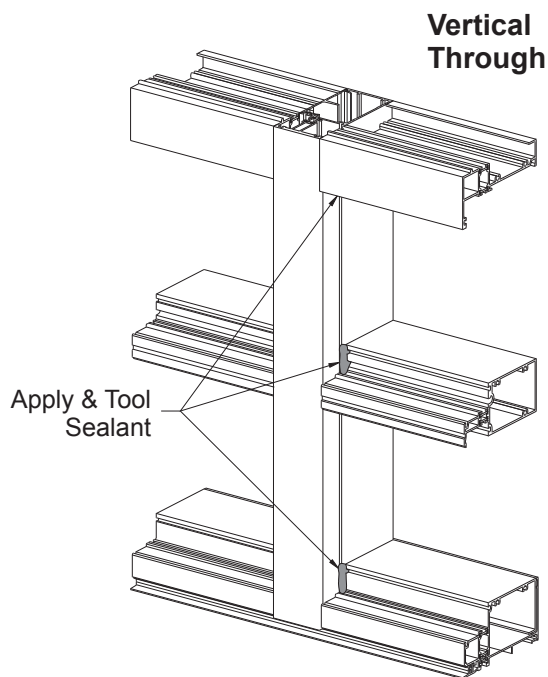

**DETAIL 50**  
Outside Glazed Shown  
Inside Glazed Similar

-Install backer rod around the perimeter of the frame between the frame and the structure.

-Apply and tool sealant to ensure a watertight joint.

See **Detail 51**.

**Note:** Interior and exterior seals are required.

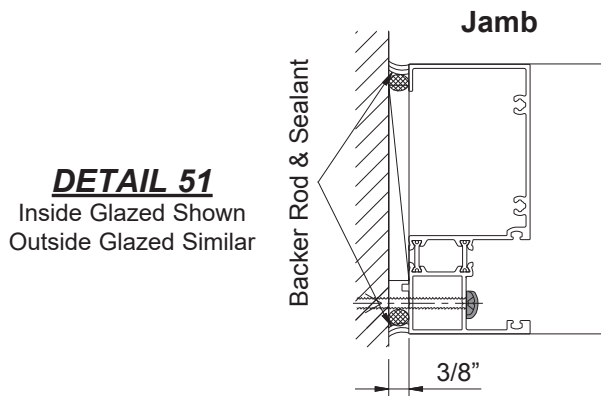
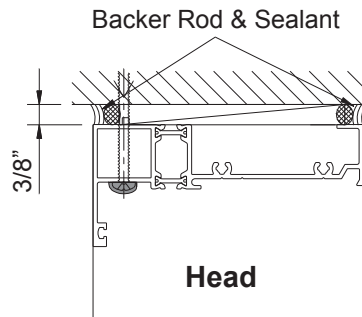

**DETAIL 51**  
Inside Glazed Shown  
Outside Glazed Similar

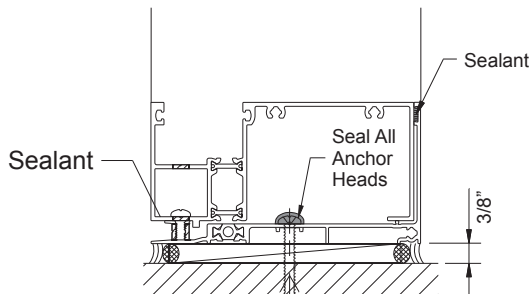

## FRAME INSTALLATION

### STEP 28

### INSTALL ASSEMBLED FRAMES WITH SLAB EDGE COVER

- Install E2-0098 sill weep baffle at each weep hole location.
- Clean the surfaces using cleaner approved by sealant manufacturer.

See **Detail 52**.

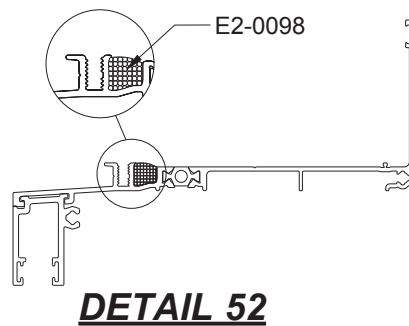

- Apply and tool sealant between wall and end dam.
- Apply and tool sealant to the sealant track on the back of the sill flashing.

See **Detail 53**.

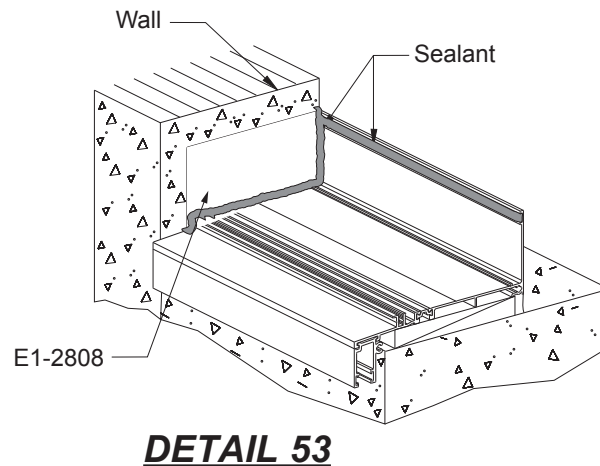

**FRAME INSTALLATION****STEP 28 (Continued)****INSTALL ASSEMBLED FRAMES WITH SLAB EDGE COVER**

- Set unglazed YWW 50 T frame into the opening pressing the excess sealant out of the sealant track on the sill flashing.
- Clean up excess sealant.
- Apply receptor snap cover into head receptor.
- Match drill hole in sill flashing for PM-1006-SS and install screws.

See **Detail 54**.

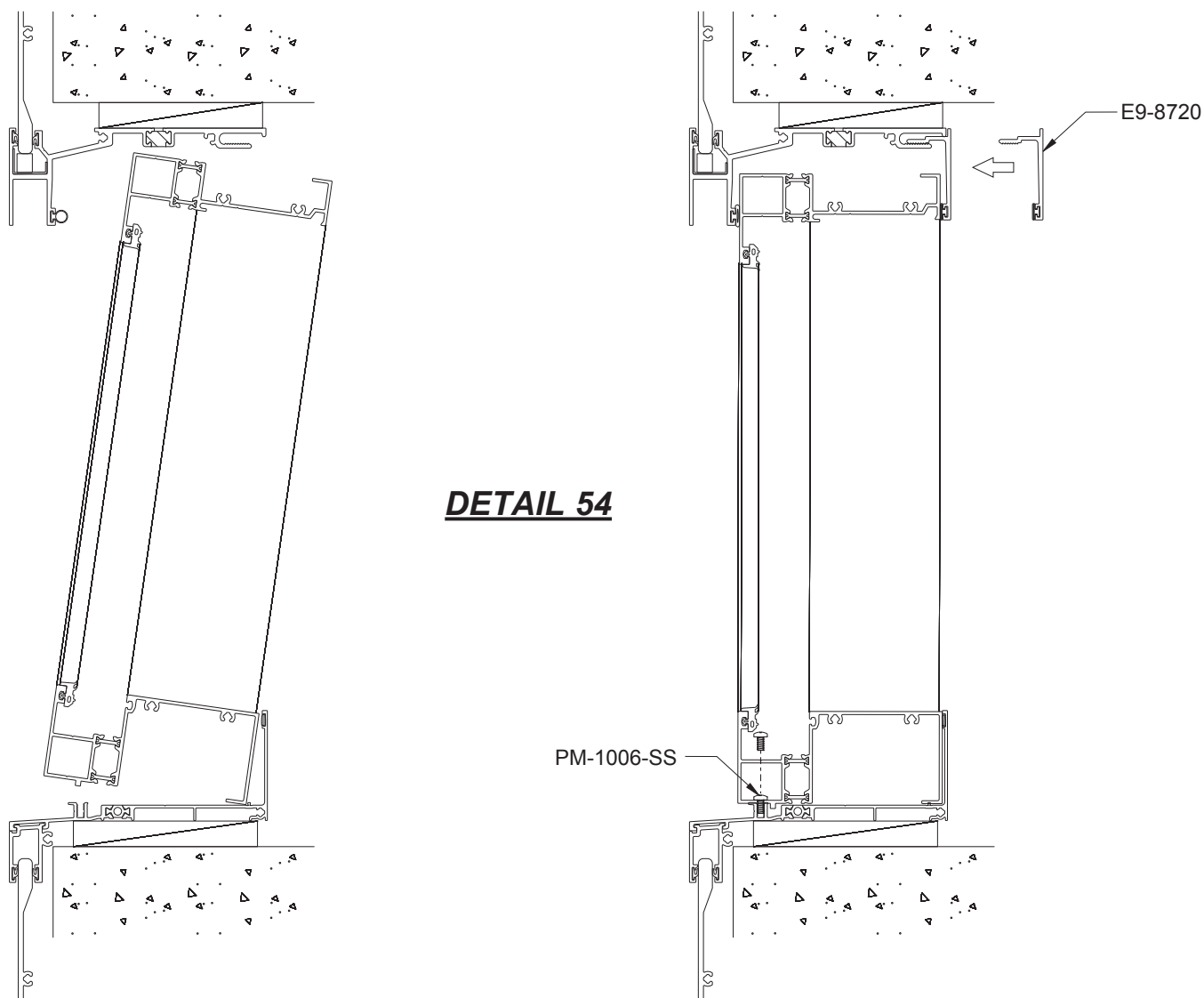

## FRAME INSTALLATION

### STEP 29 APPLY PERIMETER SEALANT

- Install backer rod and apply sealant to the back of the sill flashing and head receptor.
- Tool sealant prior to skinning over.

See **Detail 55**.

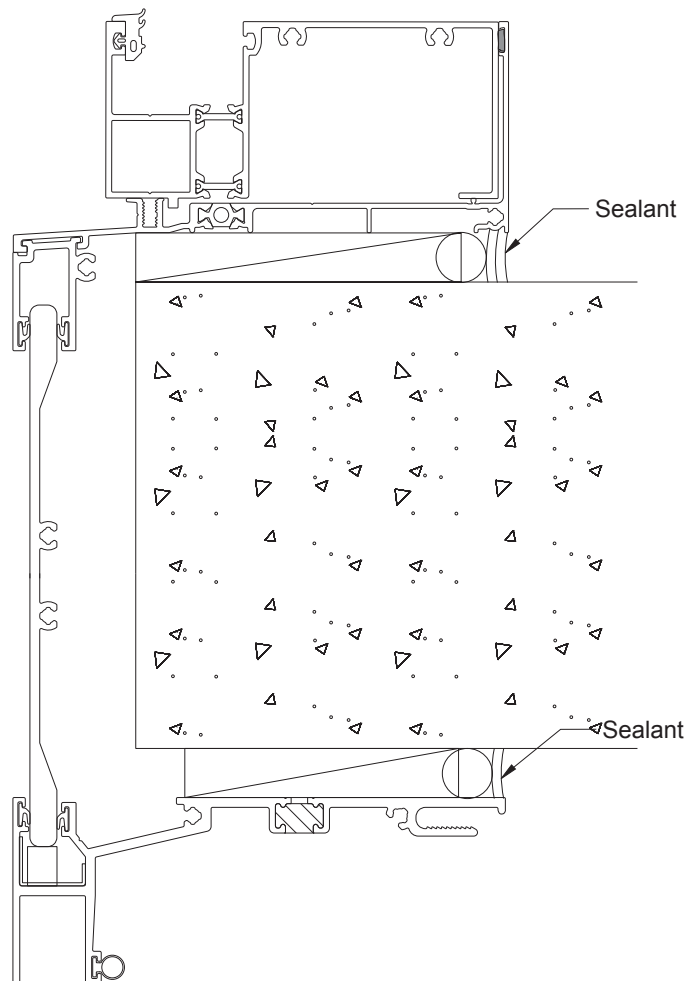

**DETAIL 55**  
**(WITH SLAB EDGE COVER)**

**FRAME INSTALLATION**

**STEP 29 Continued)  
APPLY PERIMETER SEALANT**

- Install backer rod and apply sealant to the back of the sill flashing and head receptor.
- Tool sealant prior to skinning over.

See **Detail 56**.

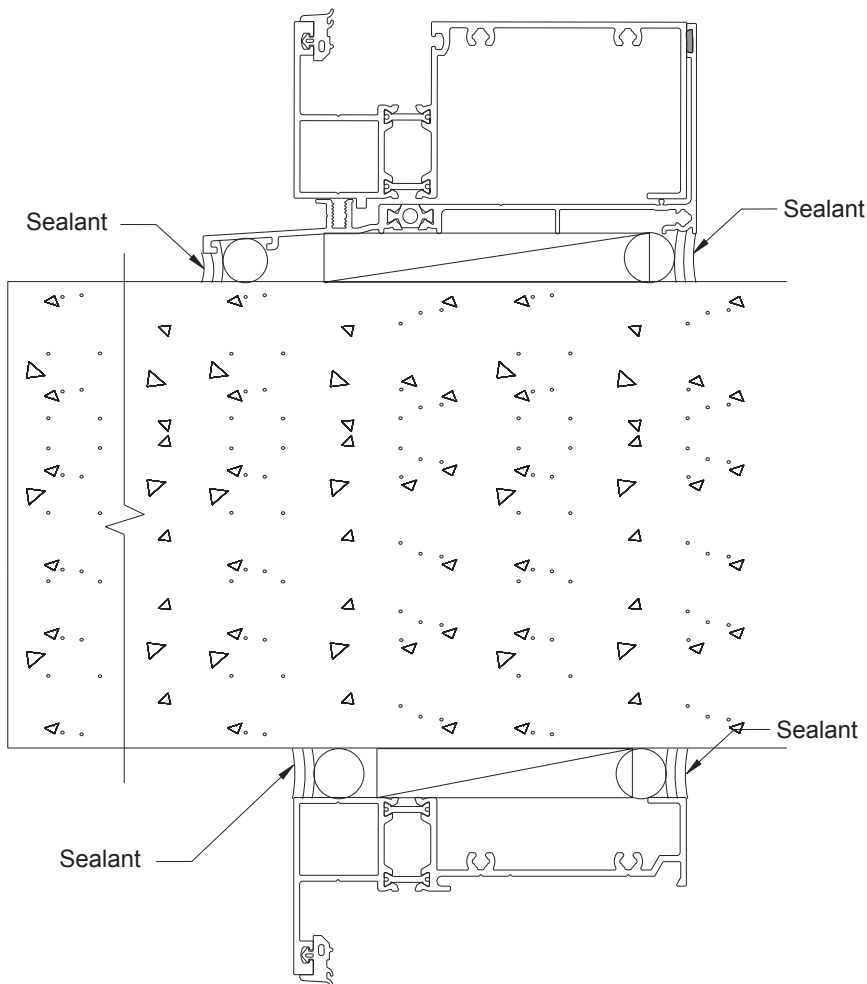

***DETAIL 56***  
**(WITHOUT SLAB EDGE COVER)**

## FRAME INSTALLATION

### STEP 30 INSTALL WATER DEFLECTORS (Standard Mullions and Jambs)

The installation of a water deflector, E2-0047, at the ends of every intermediate horizontal is required to divert water away from the insulated units.

- Clean and dry off the glazing pocket of each horizontal at the ends.
- Peel off the protective paper and install the water deflector at the end of the horizontal.
- Position the vertical leg of the deflector against the end of the horizontal.
- Apply and tool sealant along the edges of the water deflector down onto the horizontal.
- Seal the ramp of the water deflector to the sides of the glazing pocket wall.

See **Detail 57**.

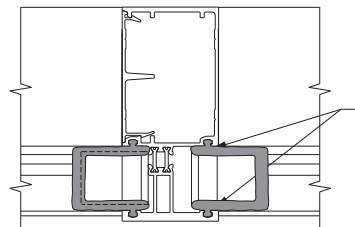
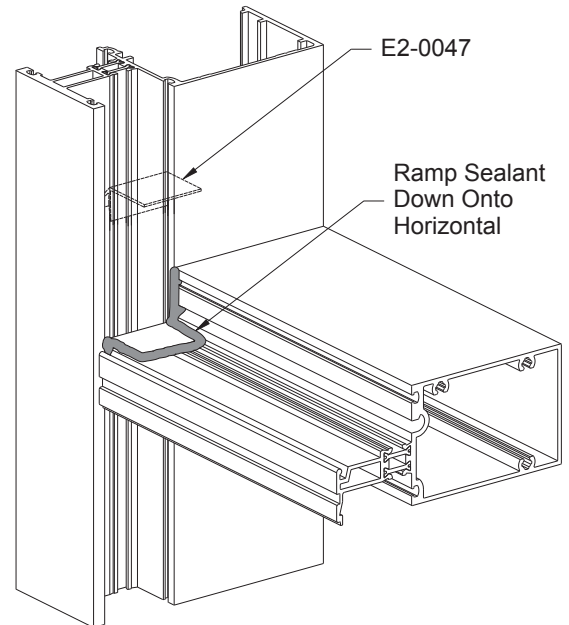

Seal Ramp of Deflector to the Pocket Wall

### **DETAIL 57**

Outside Glazed Shown  
Inside Glazed Similar

### STEP 31 INSTALL HORIZONTAL BRIDGES (For SSG Verticals Only)

The installation of horizontal bridge, E1-1038, is required to bridge the gap between intermediate horizontals at the SSG vertical.

- Clean and dry off the glazing pocket of each horizontal at the ends.
- Install E1-1038 from the underside of the horizontals with a PC-1006 fastener on each side.
- Fill the cavity of the horizontal with backer rod and completely cover the end of the horizontals with sealant.
- Apply and tool sealant at all bridge to horizontal and vertical joints to ensure a watertight seal.

See **Detail 58**.

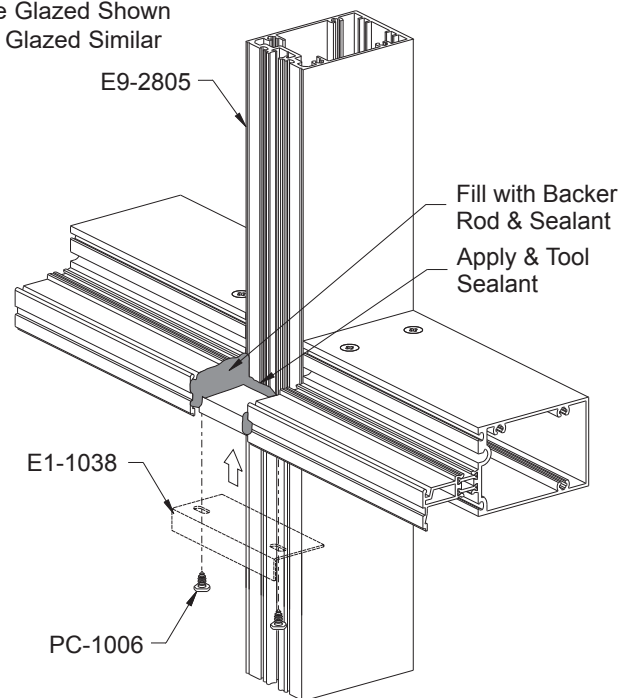

### **DETAIL 58**

**FRAME INSTALLATION**

**STEP 32  
INSTALL 1/4" GLAZING ADAPTORS  
(When Required)**

Attach the vertical glazing adaptors first.

For Standard Verticals:

- Apply sealant in the vertical gasket reglets.
- Center the vertical adaptor in the opening.
- Position the foot of the adaptor into the MegaTherm recess and rotate the other end into the gasket reglet of the mullion.

For SSG Verticals:

- Center the vertical adaptor in the opening.
- Attach the SSG glazing adaptor, E9-2716, to the mullion with PC-1010 fasteners, 2" from each end and no more than 18" on center.
- Seal all screw heads.

See **Detail 59**.

Attach the horizontal glazing adaptors last.

- Apply sealant to the ends of the horizontal glazing adaptors.
- Install the horizontal adaptors.

-Tool the sealant at the intersections of the adaptors to completely seal the joint.

See **Detail 60**.

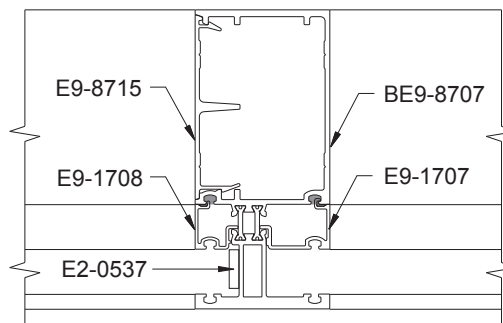

**Standard Vertical**

**DETAIL 59**

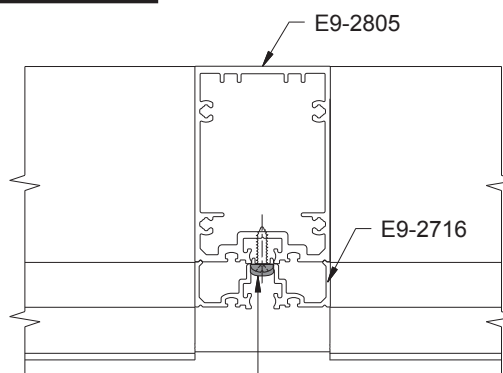

**SSG Vertical**

Seal All  
Screw Heads  
(PC-1010)

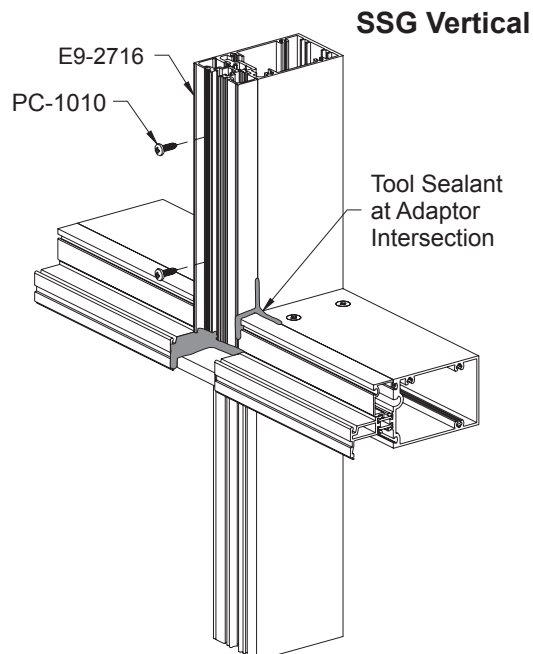
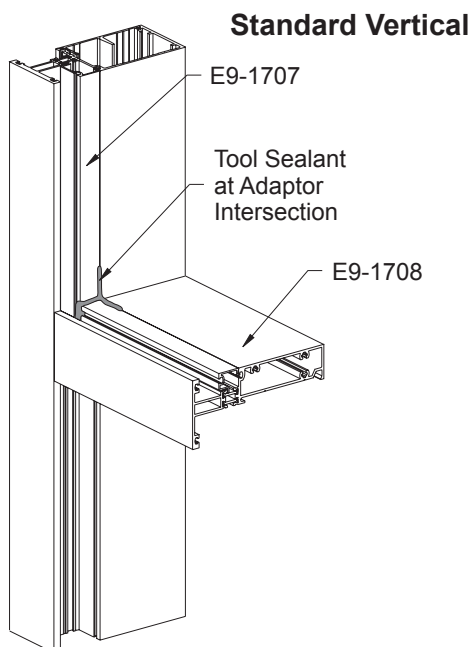

**DETAIL 60**

## GLAZING

### STEP 33 SEAL INSIDE GLAZED HORIZONTALS

Note: For Outside Glazing, skip this step and proceed to **Step 34** on **Page 50**.

Before installing the gaskets on an inside glazed window wall, the horizontals must be sealed to the verticals at the face of the system from the inside as shown in **Detail 61**.

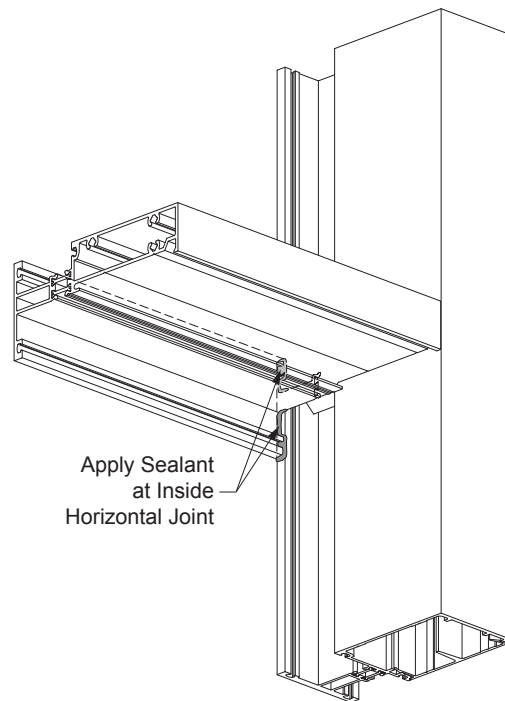

**DETAIL 61**  
Inside Glazed Shown

## GLAZING

### STEP 34 INSTALL PUSH IN GLAZING GASKETS

**For inside glazing:** Push-in gasket, E2-0801, must be installed on the exterior prior to glazing.  
**For outside glazing:** Push-in gasket, E2-0801, must be installed on the interior prior to glazing.

-Using a small brush clean out any dirt that may have accumulated in the gasket reglets.

#### Vertical glazing gaskets must be installed first:

- Cut vertical glazing gaskets to the Daylight Opening plus(+) 3/4" plus(+) an additional 1/4" for each foot of length. Notch ends of the vertical gasket as shown.
- Insert the gasket into the reglets at each end first; then insert the gasket at the midpoint of the opening.
- Push the gasket into the reglet starting at the midpoint and work towards each end.

See **Detail 62**.

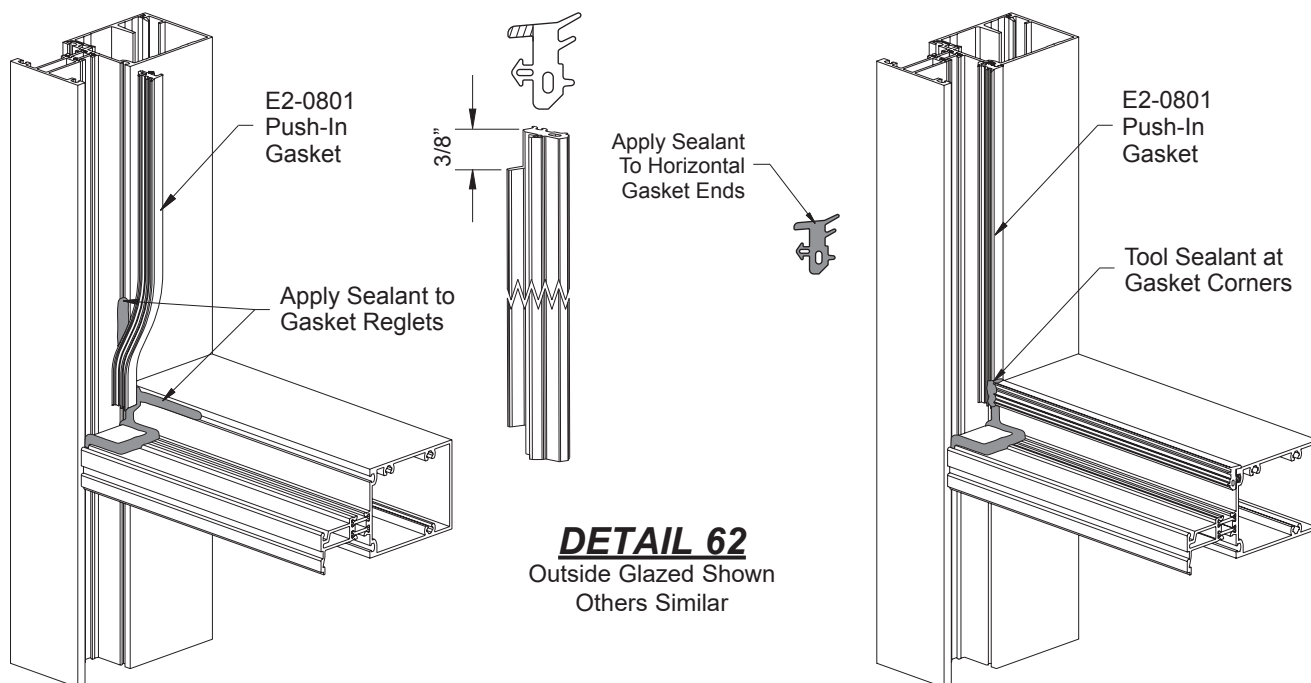

#### Install horizontal glazing gaskets next:

- Cut horizontal glazing gaskets to Daylight Opening plus(+) 1/4" for each foot of length.
- Apply sealant to each end of the horizontal glazing gasket prior to inserting into the reglet.
- Insert the gasket into the reglet at each end first; then insert the gasket at the midpoint of the opening.
- Push the gasket into the reglet starting at the midpoint and work towards each end.
- Tool the excess sealant at the gasket corners to ensure a watertight seal.

See **Detail 62**.

-See **Step 35** on **Page 53** for SSG gasket instructions.

GLAZING

**STEP 35**  
**INSTALL GLASS FOR STANDARD GLAZING**

Determine the glass size:

	Width	Height
Standard Glazing	D.L.O. + 7/8"	D.L.O. + 7/8"

- Install setting blocks at 1/4 points or according to engineering calculations.  
At intermediate horizontals: E2-0184 for 1" glazing and E2-0192 for 1/4" glazing.  
At sill conditions: E2-0182 for 1" glazing and E2-0190 for 1/4" glazing.

See **Detail 63**.

- Install side blocks, E2-0186, in the shallow glazing pocket of each vertical at the midpoint of daylight opening.
- Carefully install glass into the frame making sure that setting and side blocks are properly aligned with the glass.

**Note:** Be careful not to disengage any gaskets that have already been installed when installing glass.

See **Details 63 & 64**.

After glass is set, install one (1) E2-0153 anti-walk block at the deep pocket mullion locations.

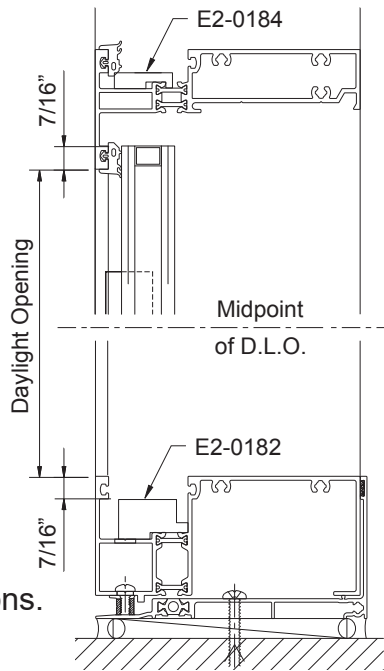

**DETAIL 63**

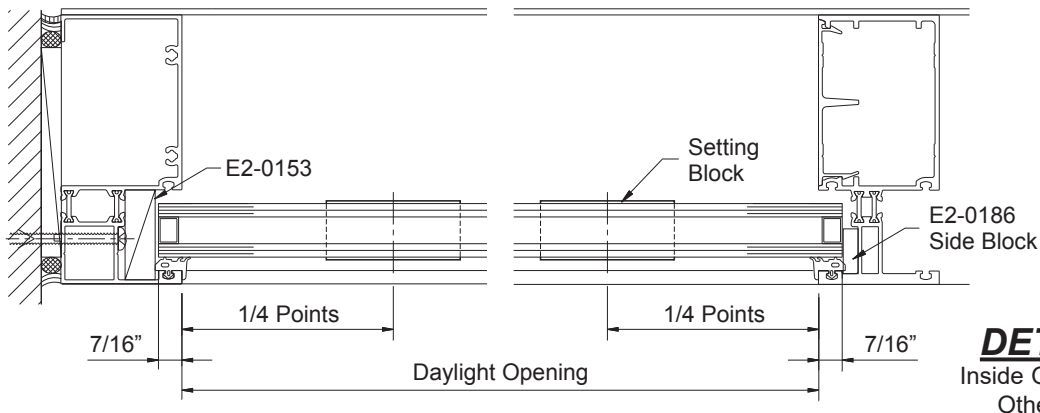

**DETAIL 64**  
Inside Glazed Shown  
Others Similar

**GLAZING**

**STEP 35 (Continued)  
INSTALL GLASS FOR STANDARD GLAZING**

**For Interior Glazing:**

Interior glass stops are required at all head and intermediate horizontals:

- E9-8711 for 1" glazing and
- E9-7703 for 1/4" glazing.

-Apply sealant to each end of the glass stops and snap them into position.

-Tool the sealant into the joint between the glass stop and the vertical to ensure a watertight seal and wipe away any excess sealant.

See **Detail 65**.

-Install the interior horizontal wedge gaskets, E2-0808, to the Daylight Opening plus(+) 1/4" for each foot of length, leaving the ends out until the vertical gasket is installed.

-Cut the vertical wedge gasket to vertical Daylight Opening plus (+) 3/4". Notch the ends of the gasket as shown in **Detail 66**.

-Insert the vertical gasket into the glazing pocket, pushing the notched ends into the horizontals.

-Apply sealant to the ends of the horizontal wedge gaskets and finish inserting them into the glazing pocket against the vertical wedge gaskets.

See **Detail 67**.

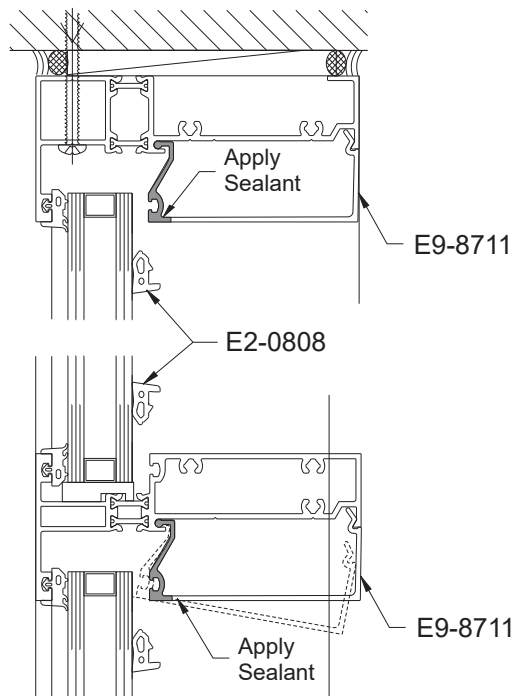

**DETAIL 65**

**DETAIL 66**

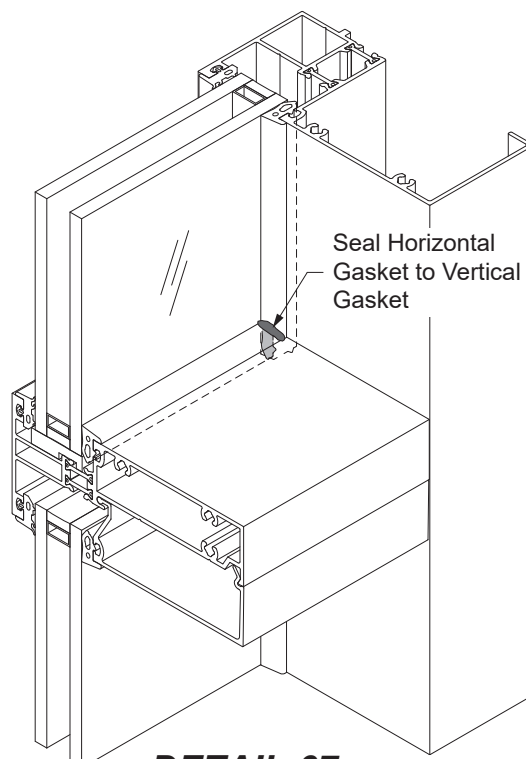
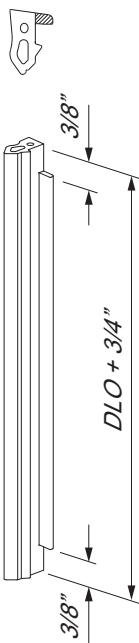

**DETAIL 67**  
Inside Glazing

GLAZING

**STEP 35 (Continued)**  
**INSTALL GLASS FOR STANDARD GLAZING**

**For Outside Glazing:**

Exterior face covers are required at all sill and intermediate horizontals:

E9-1715 for BE9-2823 horizontal members.

-Apply sealant to the ends of the face covers, and engage the hook of the face covers with the ball of the horizontal members and rotate them into position.

See **Detail 68**.

-Install the exterior horizontal wedge gaskets, E2-0808, to the Daylight Opening plus(+) 1/4" for each foot of length, leaving the ends out until the vertical gasket is installed.

-Cut the vertical wedge gasket to vertical Daylight Opening plus (+) 3/4". Notch the ends of the gasket as previously shown in **Detail 66**.

-Insert the vertical gasket into the glazing pocket, pushing the notched ends into the horizontals.  
 -Apply sealant to the ends of the horizontal wedge gaskets and finish inserting them into the glazing pocket against the vertical wedge gaskets.

See **Detail 69**.

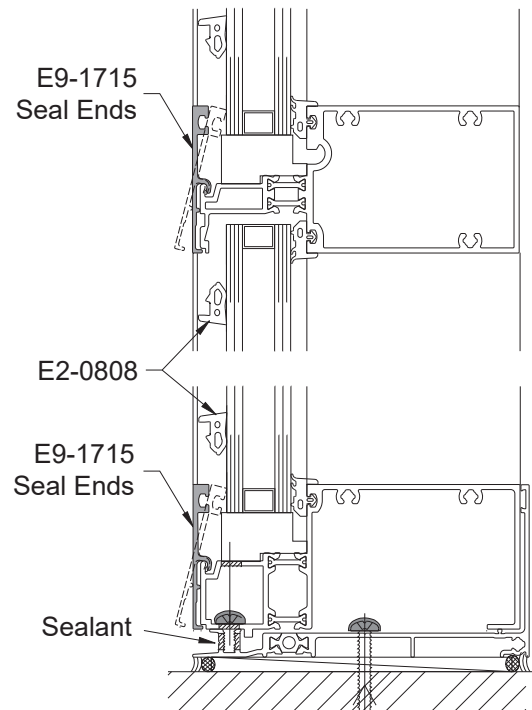

**DETAIL 68**

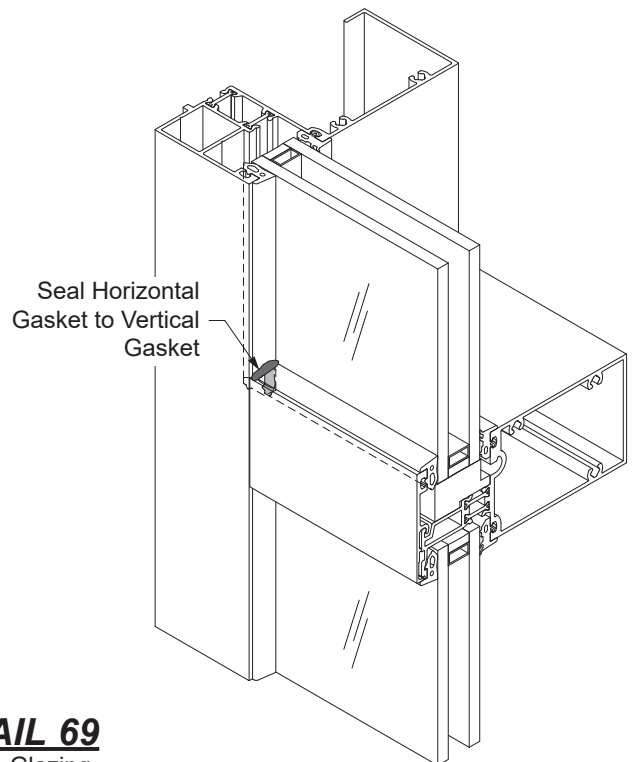

**DETAIL 69**  
 Outside Glazing

## GLAZING

### STEP 35 (Continued) INSTALL GLASS FOR STRUCTURAL SILICONE GLAZING

Determine the glass size:

	Width	Height
Jamb to SSG	D.L.O. + 1-5/16"	D.L.O. + 7/8"
SSG to SSG	D.L.O. + 1-3/4"	D.L.O. + 7/8"

-Install setting blocks at 1/4 points or according to engineering calculations.

At intermediate horizontals: E2-0184 for 1" glazing and E2-0192 for 1/4" glazing.

At sill conditions: E2-0182 for 1" glazing and E2-0190 for 1/4" glazing.

See **Detail 70**.

-Cut glazing spacer, E2-0544, to the Daylight Opening.

-Install the glazing spacer as shown in **Detail 71**.

-Install the interior glazing gaskets at the jambs and horizontals as shown in **Step 34** on **Page 50**.

-Carefully install each lite of glass leaving a 1/2" joint between lites of glass. Be careful not to disturb the interior gaskets and spacers.

-Insert the temporary glass retainers, E3-0001 for 1" glazing or E3-0006 for 1/4" glazing, between the lites and twist them 90° clockwise to engage.

-Locate temporary glass retainers 18" to 24" on center.

-Snap on exterior face covers and install exterior wedge gaskets, E2-0542, starting at one end and work towards the opposite end. Seal the ends of the horizontal wedge gasket to the vertical gasket at the jamb.

See **Detail 71**.

Determine the gasket size:

Jamb	D.L.O. + 3/4", notched at ends
Spacer	D.L.O.
Head/Sill	D.L.O. + 1/4" per Foot of D.L.O.

Notch head/sill gaskets as shown on **Page 50**. Notch jamb gaskets as shown on **Page 52**.

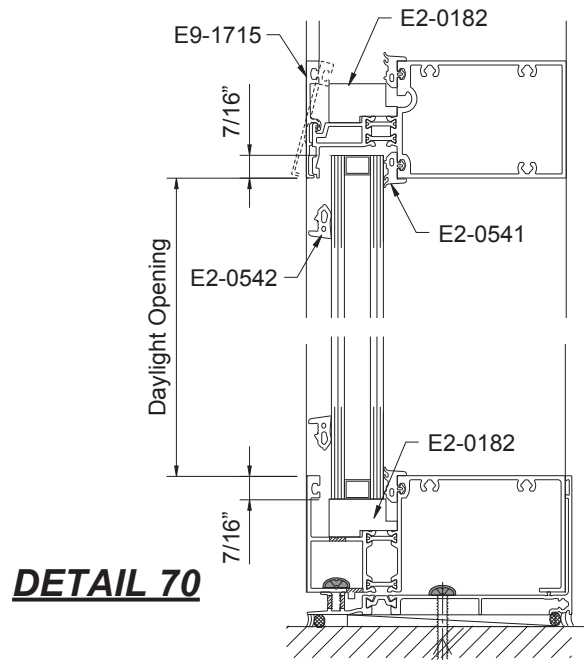

**DETAIL 70**

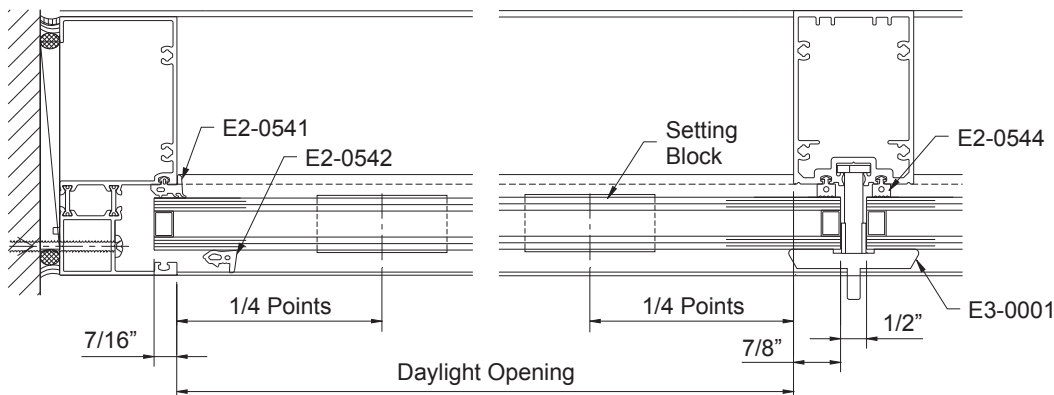

**DETAIL 71**

**GLAZING**

**STEP 35 (Continued)**

**INSTALL GLASS FOR STRUCTURAL SILICONE GLAZING**

**Apply Interior Structural Silicone:**

- Prior to applying structural silicone, clean all contact surfaces using an approved cleaner.
- Run masking tape vertically on the glass with one edge in line with the side of the mullion.
- Run another piece of masking tape vertically along the edge of the vertical next to the glass.

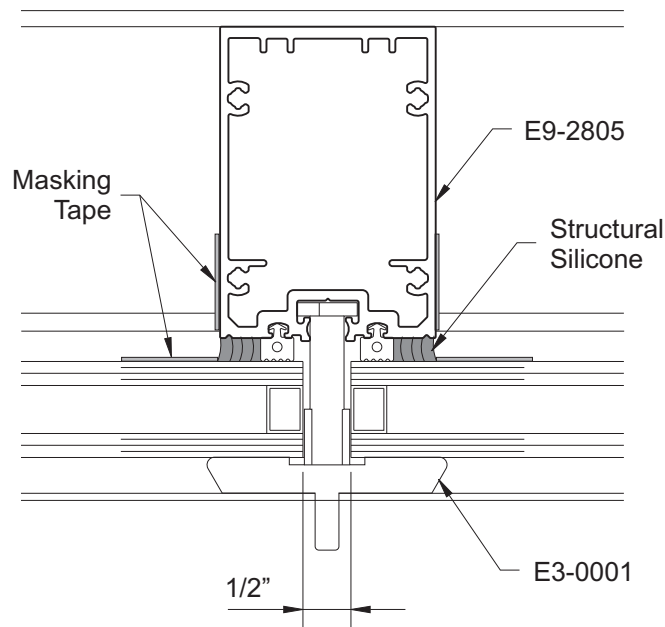

**DETAIL 72**

- Apply an approved structural silicone from the bottom to the top of the joint. Use positive pressure to completely fill the cavity between the glass and vertical mullion.
  - Using a nylon spatula or other non-scratching implement, tool the silicone immediately after running the vertical joint. Exert positive pressure while tooling to ensure that the silicone completely fills the cavity.
  - Be careful not to remove too much silicone. The silicone should make complete contact with the glass and aluminum surfaces. The finished joint should be flush with the edge of the vertical.
- See **Detail 72**.

**Caution:** Do not permit the silicone to skin over before it is tooled. Immediately remove masking tape after tooling the silicone.

**GLAZING**

**STEP 35 (Continued)  
INSTALL GLASS FOR STRUCTURAL SILICONE GLAZING**

**Apply Exterior Weatherseal:**

Interior structural silicone must be fully cured before removing temporary retainers. Please consult sealant manufacturer for recommended cure time.

- Remove the temporary glass retainers and insert a backer rod between the lites of glass.
- Clean all contact surfaces with an approved cleaner and apply masking tape to both vertical edges of the glass.
- Starting at the bottom of the lite, pump silicone into the joint between the lites of glass. Apply moderate pressure so that the void is completely filled, and tool.

**Caution:** Be careful not to puncture the backer rod or push it out of the way.

**DETAIL 73**

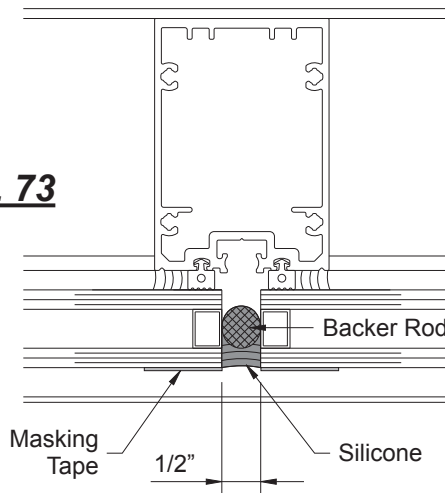

See **Detail 73**.

- At face cover splices, carry the sealant down over the face cover without sealing off the bottom to allow the system to weep properly.

See **Detail 74**.

- Using a nylon spatula or other non-scratching implement, tool the silicone immediately after running the vertical joint. Exert positive pressure while tooling to ensure that the silicone completely fills the cavity.
- Be careful not to remove too much silicone. The silicone should make complete contact with the glass and aluminum surfaces. The finished joint should be flush with the edge of the vertical.

**DETAIL 74**

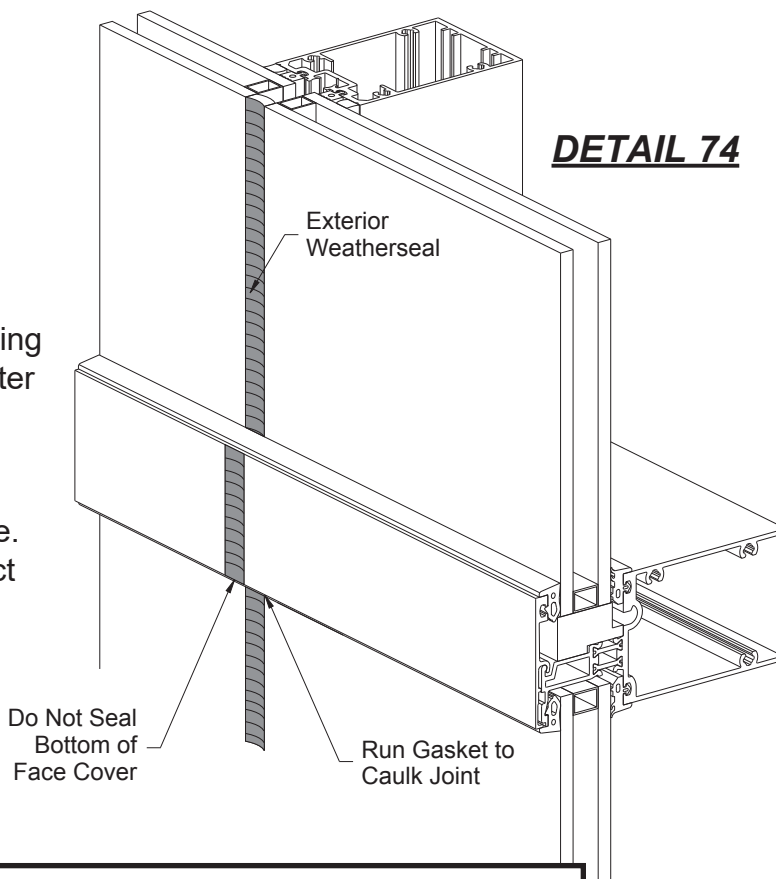

**Caution:** Do not permit the silicone to skin over before it is tooled. Immediately remove masking tape after tooling the silicone.

**DOOR FRAME INSTALLATION**

**STEP 36  
INSTALL DOOR FRAME**

Doors are shipped assembled, and door frames will be fabricated and shipped knocked down. Please refer to the 20D, 35D, & 50D Entrances Installation Manual for door installation.

Prior to snapping the assembled frames into the door jamb, the end of the sill flashing needs to be sealed to the door jamb.

- Apply and tool sealant to all sill flashing to door jamb joints.
- Apply a liberal amount of sealant to completely fill the door jamb cavity and ramp the sealant down onto the sill flashing.

See **Detail 75**.

Glass sizes for transom areas are not the same as for standard YWW 45 T frames. See the table below and **Detail 76** for transom glass sizes.

**Transom Glass Sizes:**

	Width	Height
Transom Glazing	D.L.O. - 1/8"	D.L.O. + 7/8"

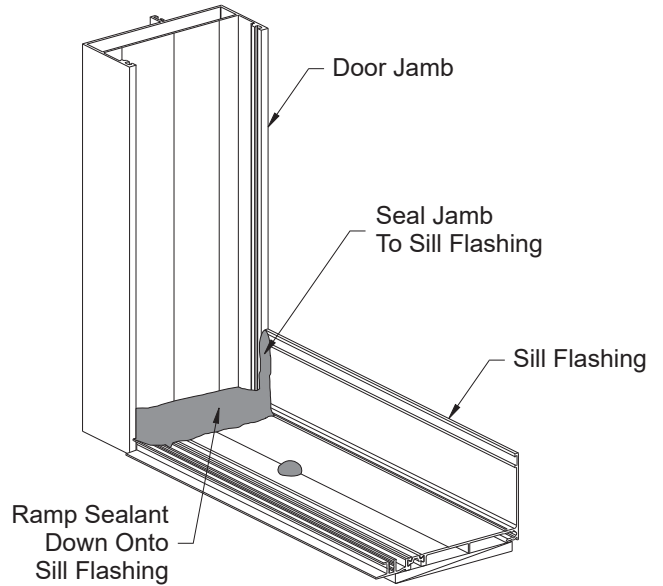

**DETAIL 75**

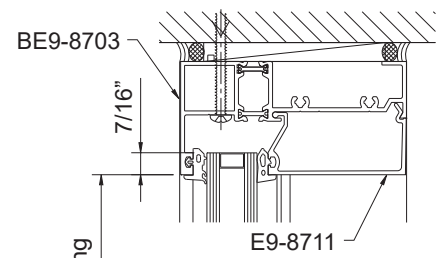

**DETAIL 76**

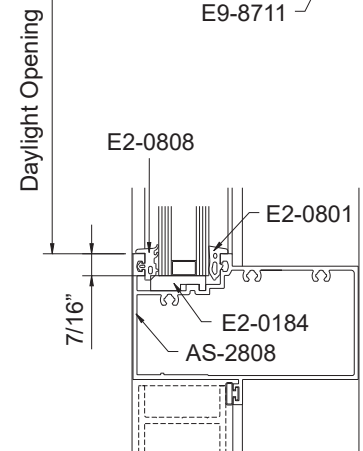
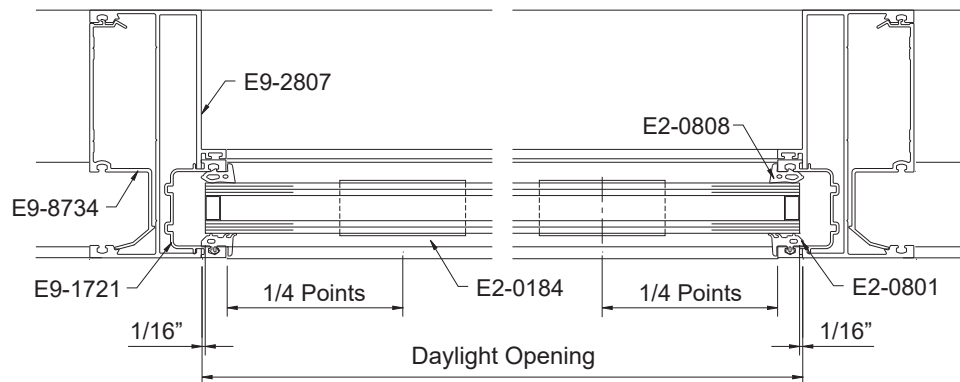



270 Riverside Parkway  
Suite 100  
Austell, Georgia 30168  
[www.ykkap.com](http://www.ykkap.com)