

YWW 40 T / 45 T Thermal Window Wall System

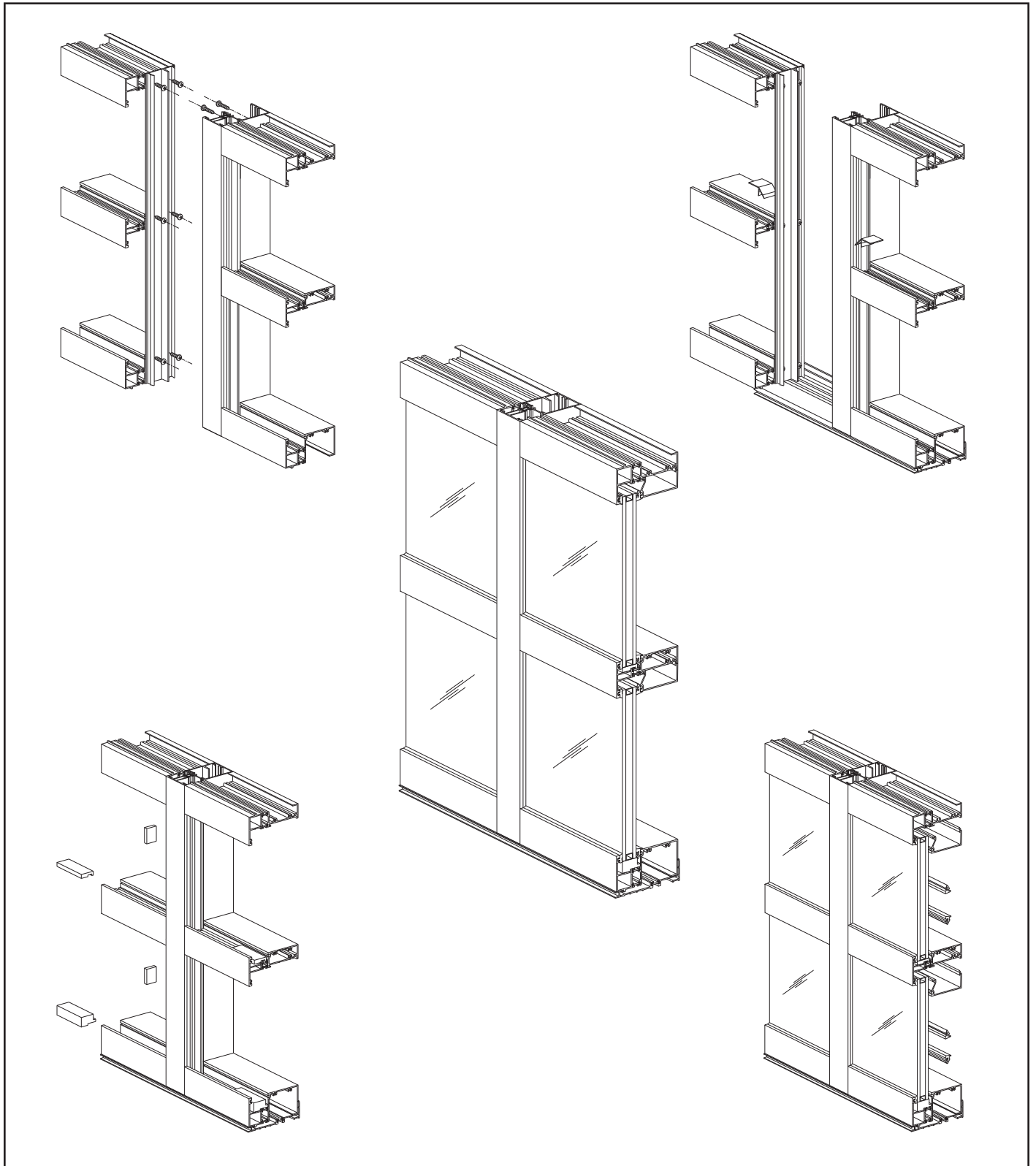

Installation Manual

TABLE OF CONTENTS











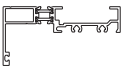
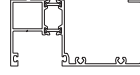
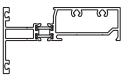
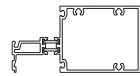

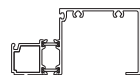
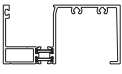
Installation Notes	Page ii
PARTS DESCRIPTION	
YWW 40 T Framing Members	Page 1
YWW 45 T Framing Members	Pages 1 to 3
YWW 45 T Door Framing Members	Page 4
YWW 40 T / YWW 45 T Accessories	Pages 5 & 6
FRAME FABRICATION	
Determine Frame Size	Page 7
Fabricate Sill Flashing	Page 8
Fabricate Head & Sill Members	Pages 9 & 10
Fabricate Two Piece Verticals & Jamb Members	Pages 11 & 12
Fabricate One Piece SSG Verticals	Page 12
Fabricate Intermediate Horizontal Members	Page 13
Fabricate Interior Glass Stops & Exterior Face Covers	Pages 13 & 14
Fabricate Glazing Adaptors	Page 15
FRAME ASSEMBLY	
Attach Mullion End Caps	Page 16
Install End Dams	Page 16
Assemble Frames	Pages 17 & 18
FRAME INSTALLATION	
Install Sill Flashing	Page 19
Install Assembled Frames	Page 20
Apply Internal & Perimeter Sealant	Page 21
Install Water Deflectors & Horizontal Bridges	Page 22
Install 1/4" Glazing Adaptors	Page 23
GLAZING	
Install Glazing Gaskets	Page 24
Install Glass for Standard Glazing	Pages 25 to 27
Install Glass for Structural Silicone Glazing	Pages 28 to 30
DOOR FRAME INSTALLATION	
Install Door Frame	Page 31

Installation Notes

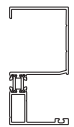
1. Do not drop, roll or drag boxes of aluminum framing. Move and stack boxes with proper support to prevent distortion. If fork lifts are used be especially careful about striking the boxes when lifting or moving.
2. Store in a dry, out of the way area. If rain exposure, condensation or any water contact is likely, then all packaging material should be removed. Wet packaging materials will discolor and may stain aluminum finishes and paints.
3. All materials should be checked for quantity and quality upon receipt, YKK AP must be notified immediately of any discrepancies in shipment. Check to make sure that you have the required shims, sealants, supplies and tools necessary for the installation.
4. Carefully check the openings and surrounding conditions that will receive your material. Remember, if the construction is not per the construction documents, it is your responsibility to notify the general contractor in writing. Any discrepancies must be brought to the general contractor's attention before you proceed with the installation.
5. Gather your shop drawings, materials, packing list and this installation manual. Carefully review parts location, the sequence it goes therein when you glaze it and how you seal it. Installation instructions are of a general nature and may not cover every condition you encounter. The shop drawings and/or installation manuals were prepared specifically for the product.
6. Any material substitutions must be of equal or greater quality.
7. Make certain that material samples have been sent for compatibility testing for all manufacturer's sealants involved. Make certain that sealants have been installed in strict accordance with the manufacturer's recommendations and specifications.
8. Remember to isolate, in an approved manner, all aluminum from uncured masonry or other incompatible materials.
9. System-to-structure fasteners are not supplied by YKK AP. Fasteners called out on shop drawings are to indicate minimum sizes for design loading.
10. Entrances are to be installed plumb, square, level and true.
11. If any questions arise concerning YKK AP products or their installation, contact YKK AP for clarification before proceeding.
12. YKK AP store front and/or curtain wall framing is typically completed before drywall, flooring and other products that may still be in process. Take the extra time to wrap and protect the work produced.
13. Cutting tolerances are plus zero, minus one thirty second unless otherwise noted.
14. Check our website, www.ykkap.com, for the latest installation manual update prior to commencing work.

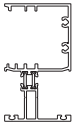

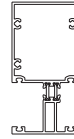
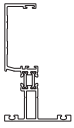







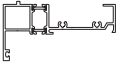
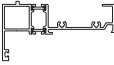
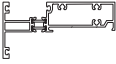
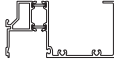
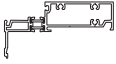
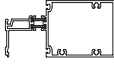

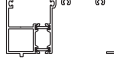

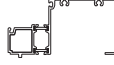
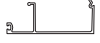



YWW 40 T INSIDE GLAZED

YWW 45 T OUTSIDE GLAZED

	Head 2" x 4"	BE9-2202		Head/Jamb 2-1/4" x 4-1/2"	BE9-1704
	Horizontal 2-1/4" x 4"	BE9-2206		Horizontal 2-1/4" x 4-1/2"	BE9-1716
	Interior Glass Stop Use with BE9-2202 & BE9-2206	E9-2204		Sill 2-1/4" x 4-1/2"	BE9-1714
	Sill/Jamb 2" x 4"	BE9-2201		Horizontal Exterior Face Cover Use with BE9-1716 & BE9-1714	E9-1715
	Sill Flashing	BE9-2205		Sill Flashing	BE9-2711
	Jamb 2" x 4"	BE9-2203		Mullion 2-1/4" x 4-1/2" For Screw Spline Assembly	BE9-1701
	Mullion 2-1/4" x 4"	BE9-2207		Mullion Flush Filler Use with BE9-1701	E9-1702
	Mullion Flush Filler Use with BE9-2207	E9-2208		Mullion 2-1/4" x 4-1/2" For Shear Block Assembly	BE9-1722
	Expansion Mullion (Female) Use with E9-2210	BE9-2209			
	Expansion Mullion (Male) Use with BE9-2209	E9-2210			

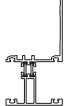











YWW 45 T INSIDE GLAZED

YWW 45 T S.S.G.

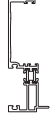

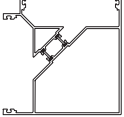
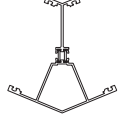



	Head 2-1/4" x 4-1/2"	BE9-1703		Head 2-1/4" x 4-1/2"	BE9-1703
	Horizontal 2-1/4" x 4-1/2"	BE9-1706		Head 2-1/4" x 4-1/2" For Spliced Runs Longer Than 24'-0"	BE9-1740
	Horizontal 2-1/4" x 4-1/2" (Outside Glazed Option)	BE9-1750		Horizontal 2-1/4" x 4-1/2"	BE9-1726
	Horizontal Exterior Face Cover Use with BE9-1750	E9-1730		Sill/Jamb 2-1/4" x 4-1/2"	BE9-1704
	Interior Glass Stop For 1" Glazing Use with BE9-1703 & BE9-1706	E9-1705		Sill 2-1/4" x 4-1/2" For Spliced Runs Longer Than 24'-0"	BE9-1714
	Interior Glass Stop For 1/4" Glazing Use with BE9-1703 & BE9-1706	E9-1713		Horizontal Exterior Face Cover Use with BE9-1750	E9-1730
	Horizontal 2-1/4" x 3"	BE9-1733		Interior Glass Stop For 1" Glazing Use with BE9-1703 & BE9-1750	BE9-1714
	Interior Glass Stop For 1" Glazing Use with BE9-1733	E9-1734		Interior Glass Stop For 1/4" Glazing Use with BE9-1703 & BE9-1750	E9-1715
	Sill/Jamb 2-1/4" x 4-1/2"	BE9-1704		Sill Flashing	BE9-1510
	Sill Flashing	BE9-1510		Mullion For Structural Silicone Glazing	E9-2715
	Mullion 2-1/4" x 4-1/2" For Screw Spline Assembly	BE9-1701		Expansion Mullion (Female) For S.S.G. Use with E9-1736	E9-1735
	Mullion Flush Filler Use with BE9-2207	E9-1702		Expansion Mullion (Male) For S.S.G. Use with E9-1735	E9-1736

YWW 45 T S.S.G.

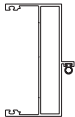
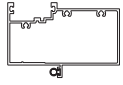
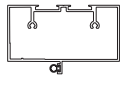

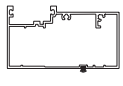
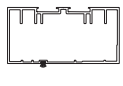
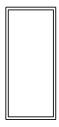







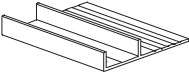
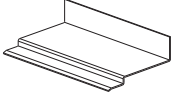

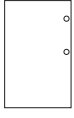
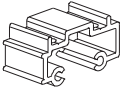

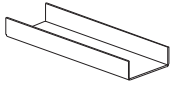
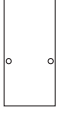
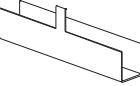

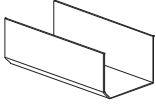

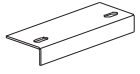

YWW 45 T S.S.G.

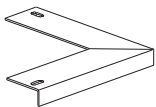
	<p>90° Corner Mullion For Structural Silicone Glazing</p>	<p>E9-2718</p>		<p>Outside Hinged Mullion (Male) 3° to 20° Use with BE9-1727</p> <p>BE9-1728</p>
	<p>Glazing Adaptor For 1/4" Glazing Use with E9-2715</p>	<p>E9-2716</p>		<p>Inside Hinged Mullion (Male) 3° to 15° Use with BE9-1727</p> <p>BE9-1729</p>
	<p>Deep Pocket Glazing Adaptor For 1/4" Glazing</p>	<p>E9-1707</p>		
	<p>Shallow Pocket Glazing Adaptor For 1/4" Glazing</p>	<p>E9-1708</p>		
	<p>Glazing Pocket Flush Filler For 1" Glazing</p>	<p>BE9-7856</p>		
	<p>Expansion Mullion (Female) Use with BE9-1744</p>	<p>BE9-1743</p>		
	<p>Expansion Mullion (Male) Use with BE9-1743</p>	<p>BE9-1744</p>		
	<p>90° Corner Mullion Use with (2) BE9-1709</p>	<p>BE9-1710</p>		
	<p>135° Corner Mullion Use with (2) BE9-1709</p>	<p>BE9-1737</p>		
	<p>Glazing Pocket Filler For 1" Glazing</p>	<p>BE9-1709</p>		
	<p>Pocket Filler Glazing Adaptor For 1/4" Glazing</p>	<p>E9-1725</p>		
	<p>Hinged Mullion (Female) 3° to 20° Use with BE9-1728 & BE9-1729</p>	<p>BE9-1727</p>		

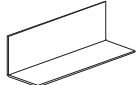

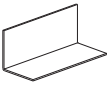

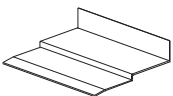



















YWW 45 T DOOR FRAMING

	<p>Single Acting Door Jamb Elastomer Weathering E2-0051 Included</p>	AS-1717		
	<p>Single Acting Transom Head Elastomer Weathering E2-0051 Included</p>	AS-1718		
	<p>Single Acting Transom Head Elastomer Weathering E2-0051 Included</p>	AS-1565		
	<p>Double Acting Door Jamb</p>	E9-1719		
	<p>Double Acting Transom Head Pile Weathering E2-0062 Included</p>	AS-1720		
	<p>Double Acting Transom Head Pile Weathering E2-0062 Included</p>	AS-1566		
	<p>Intermediate Door Jamb (2" x 4-1/2" Tube) Use with AS-0401</p>	E9-9312		
	<p>Glazing Pocket Filler For 1" Glazing</p>	BE9-1709		
	<p>Transom Glazing Pocket Filler For 1" Glazing</p>	E9-1721		
	<p>Door Stop Assembly (E9-0409 & E9-1113 Mill) Elastomer Weathering E2-0051 Included</p>	AS-0401		
	<p>Threshold 1/2" x 4"</p>	E9-0407		

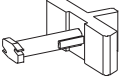
YWW 40T / 45 T ACCESSORIES

	"F" Anchor For Head & Jamb	E1-1026		Splice Sleeve For BE9-2205 Sill Flashing (YWW 40 T)	E1-0123
	Shear Clip For BE9-1706 & BE9-1750 Horizontal Use (4) PC-1210 Not Included	E1-1040		Mullion End Cap For Expansion Vertical	E1-0176
	Shear Block For BE9-1726 Horizontal Use (2) PC-1228 & (2) FC-1212 Not Included	E1-1037		Mullion End Cap For S.S.G. Vertical	E1-1047
	Joint Sleeve For S.S.G. Head & Sill BE9-1704 (Exterior Side)	E1-1027		Mullion End Cap For Standard Vertical	E3-0034
	Joint Sleeve For S.S.G. Head & Sill BE9-1740 (Exterior Side)	E1-1028		End Dam For Frame Ends Where Head & Sill Run Through (Large Cavity)	E2-0193
	Joint Sleeve For S.S.G. Head & Sill BE9-1704 & BE9-1740 (Interior Side)	E1-1029		End Dam For Frame Ends Where Head & Sill Run Through (Small Cavity)	E2-0194
	Water Deflector For Horizontals at Standard Vertical	E2-0047		Setting Block At Sill For YWW 40 T 1" Glazing	E2-0228
	Horizontal Bridge For Horizontals at S.S.G. Vertical	E1-1038		Setting Block At Sill For YWW 45 T 1" Glazing	E2-0182
	Horizontal Bridge For Horizontals at 90° S.S.G. Corner Mullion	E1-1039		Setting Block At Intermediate Horizontal For YWW 40T & 45 T 1" Glazing	E2-0184
	End Dam For BE9-1510 Sill Flashing (YWW 45 T)	E1-0168		Setting Block At Sill For YWW 45 T 1/4" Glazing	E2-0190
	End Dam For BE9-2205 Sill Flashing (YWW 40 T)	E1-1083		Setting Block At Intermediate Horizontal For YWW 45 T 1/4" Glazing	E2-0192
	Splice Sleeve For BE9-1510 Sill Flashing (YWW 45 T)	E1-0174		Side Block For YWW 40T & 45 T	E2-0186

YWW 40T / 45 T ACCESSORIES

	Wedge Glazing Gasket For YWW 40 T	E2-0160		Steel Bar Reinforcing 3/16" x 2-1/4" For BE9-2718 (S.S.G.)	E1-0169
	Wedge Glazing Gasket For YWW 45 T	E2-0808		#8 x 1/2" FHSMS Type "AB", Zinc Plated Steel For Hinged Mullions	FC-0808
	Push-In Glazing Gasket For YWW 40 T & 45 T	E2-0801		#10 x 3/8" FHSMS Type "AB", Zinc Plated Steel For Attachment of Standard Mullion End Cap	FC-1006
	Exterior Glazing Gasket For YWW 45 T S.S.G.	E2-0542		#10 x 3/8" PHSMS Type "AB", Zinc Plated Steel For Attachment of E1-1038 S.S.G. Horizontal Bridge	PC-1006
	Interior Glazing Gasket For YWW 45 T S.S.G.	E2-0541		#10 x 5/8" PHSMS Type "AB", Zinc Plated Steel For Attachment of E9-2716 S.S.G. Glazing Adaptor	PC-1010
	Glazing Spacer For YWW 45 T S.S.G. 1" Glazing	E2-0544		#10 x 7/8" PHMS Type "AB" Zinc Plated Steel, For Attach. of Sill Member BE9-2201 to Sill Flashing BE9-2205	PM-1014-SS
	Glazing Spacer For YWW 45 T S.S.G. 1/4" Glazing	E2-0543		#12 x 1/2" FHSMS Type "AB", Zinc Plated Steel For Attachment of SSG & Exp. Mullion End Cap	FC-1208
	Weathering Gasket For Expansion Mullions BE9-2209 & BE9-1743	E2-0065		#12 x 3/4" FHSMS Type "AB", Zinc Plated Steel For Attachment of Horizontal to Shear Block, E1-1037	FC-1212
	Anti-walk Block For Deep Pocket	E2-0153		#12 x 5/8" PHSMS Type "AB" For Attachment of Shear Block, E1-1040, to Vertical & Horizontal	PC-1210
	Temporary Glass Retainer For 1" S.S.G. Glazing	E3-0001		#12 x 1" PHSMS Type "AB" Zinc Plated Steel, For Attachment of Head, Horiz. & Sill to Two-Piece Verticals	PC-1216
	Temporary Glass Retainer For 1/4" S.S.G. Glazing	E3-0006		#12 x 1-1/4" PHSMS Type "AB", Zinc Plated Steel For Attachment of Head, Horizontal & Sill to Jamb	PC-1220
	Steel Bar Reinforcing 1/4" x 2-1/4" For BE9-1701 (Standard)	E1-0151		#12 x 1-3/4" PHSMS Type "AB", Zinc Plated Steel For Attachment of Shear Block, E1-1037 to Vertical	PC-1228

FRAME FABRICATION

STEP 1 DETERMINE FRAME SIZE

Determine Frame Width:

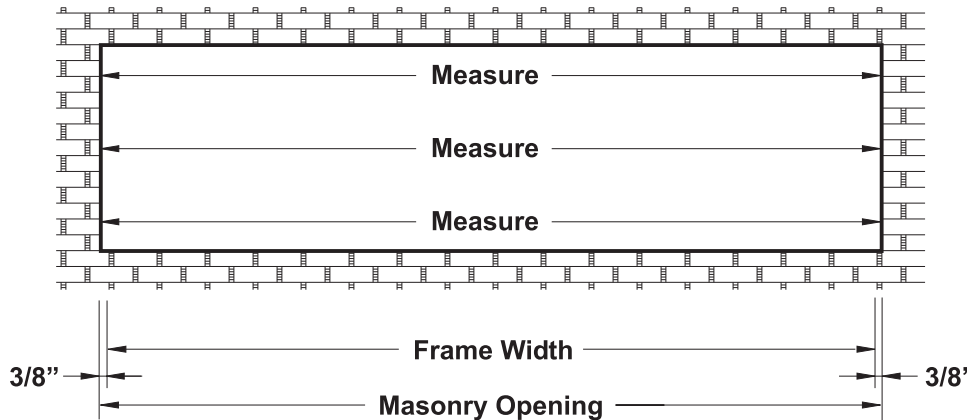

Note: Check the opening for squareness and plumb at both ends. Units must be installed in a true rectangle.

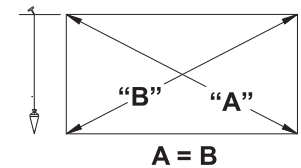

Detail 1

- Measure the width of the masonry opening at the top, middle, and bottom.
 - Select the smallest dimension measured and subtract 3/4" to determine the frame width.
- See **Detail 1**.

Determine Frame Height:

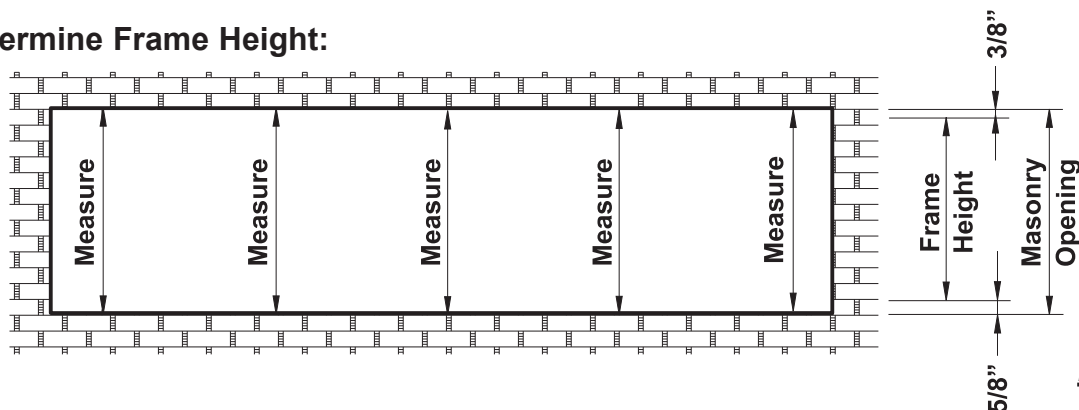

Detail 2

- Measure the height of the masonry opening in several places along the entire length of the opening.
- Select the smallest dimension measured and subtract 1" to determine the frame height to be used:
 - 3/8" for the shim/caulk joint at the head.
 - 3/8" for the sill flashing BE9-1510 for YWW 45 T or BE9-2205 for YWW 40 T.
 - 1/4" for the shim/caulk joint below the sill flashing.

See **Detail 2**.

NOTE: Vertical through frame widths over 24'-0" require expansion mullions every 12 to 15 feet (best location at vertical next to door jamb.)

FRAME FABRICATION

STEP 2 FABRICATE SILL FLASHING

YWW 45 T / 40 T requires the use of extruded sill flashing for mullion through frames:

- Use sill flashing BE9-1510 for YWW 45 T.
- Use sill flashing BE9-2205 for YWW 40 T.

- Cut the sill flashing, BE9-1510 (YWW 45 T) or BE9-2205 (YWW 40T), to the frame width determined in **Step 1**: Frame Width plus(+) 1/4" at each jamb.
- For openings longer than 24'-0" the sill flashing needs to be spliced every twelve to fifteen feet.
- Allow for a 3/8" splice joint between sill flashing members.
- Mark the centerline of each vertical mullion on the sill flashing.

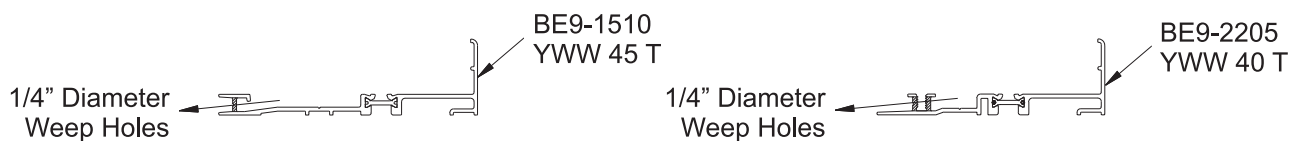
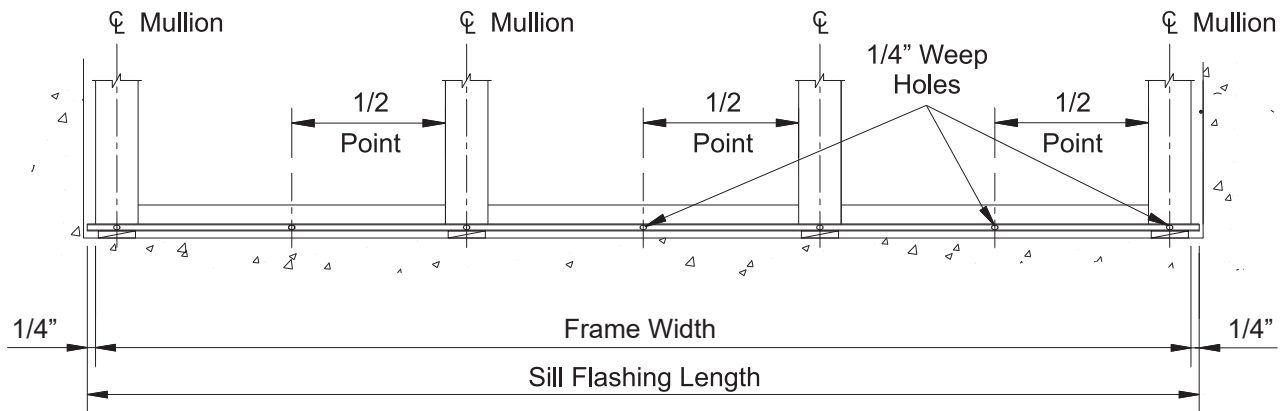

Detail 3

-Drill a 1/4" diameter weep hole in the face of the sill flashing at the centerline of each vertical mullion and at the midpoints between vertical mullions.

Using the drill, slightly elongate each hole to create an oval. 

See **Detail 3**.

NOTE: Sill flashing is not required when head and sill members run continuous.

FRAME FABRICATION

STEP 3 FABRICATE HEAD & SILL MEMBERS

FOR MULLION THROUGH FRAMES

-Cut all head and sill members to the daylight opening between mullions.

Sill member, BE9-2201 for YWW 40 T, requires additional fabrication for anchoring to the sill flashing:

- Measure in 6" from each end of the sill member and mark hole locations along the glazing pocket "V"-groove.
- Mark additional hole locations a maximum of 24" on center (O.C.).
- Drill a 0.213" diameter (#3 drill bit) hole at each location marked.

See **Detail 4**.

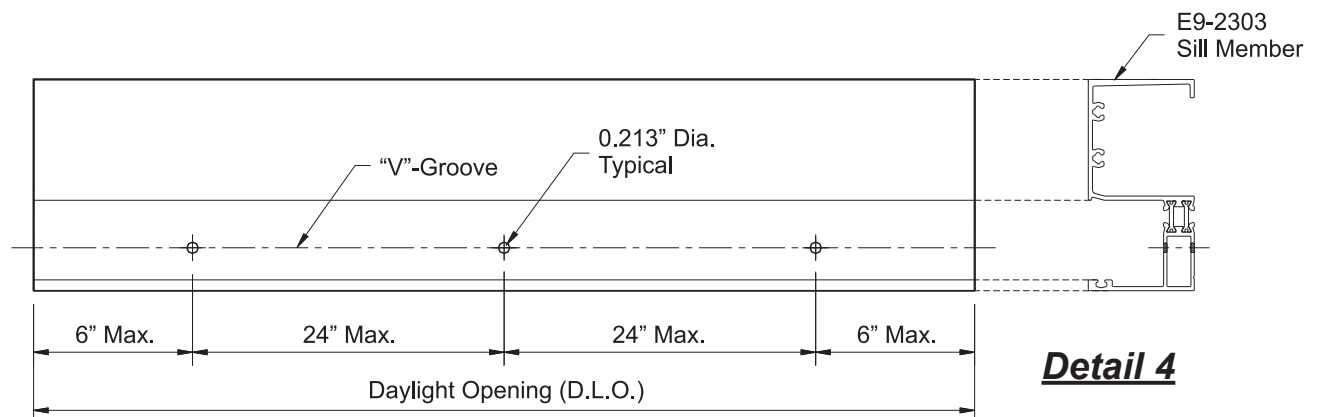

FOR CONTINUOUS HEAD & SILL FRAMES (YWW 45 T SSG Only)

With the YWW 45 T Structural Silicone Glazed (SSG) option, head and sill members may run continuously across the frame.

For Frames 24'-0" or shorter:

- Cut the head and sill members, BE9-1704, to the frame width determined in **Step 1**.

For Frames Longer Than 24'-0":

- Head member BE9-1740 and sill member BE9-1714 must be used instead of BE9-1704.
- Determine the location of the expansion mullions from the shop drawings (typically ten to fifteen feet on center).
- Cut the head and sill members to the dimension between the jamb and expansion mullions at end members and between the expansion mullions for intermediate members.

FRAME FABRICATION

STEP 3 (Continued)

FABRICATE HEAD & SILL MEMBERS

FOR CONTINUOUS HEAD & SILL FRAMES (YWW 45 T SSG Only)

-Mark the centerline of each SSG mullion along the head and sill members.
 -Mark hole locations on the head and sill for screw spline attachment of mullions using one of the methods below:

-Using short pieces of mullions as a template, align the template with the mullion centerline and the front of the head/sill and mark hole locations through the screw splines.

OR

-Layout hole locations on head and sill members as shown in **Detail 5**.

-Drill 0.236" diameter (#B drill bit) clearance holes at each location marked.

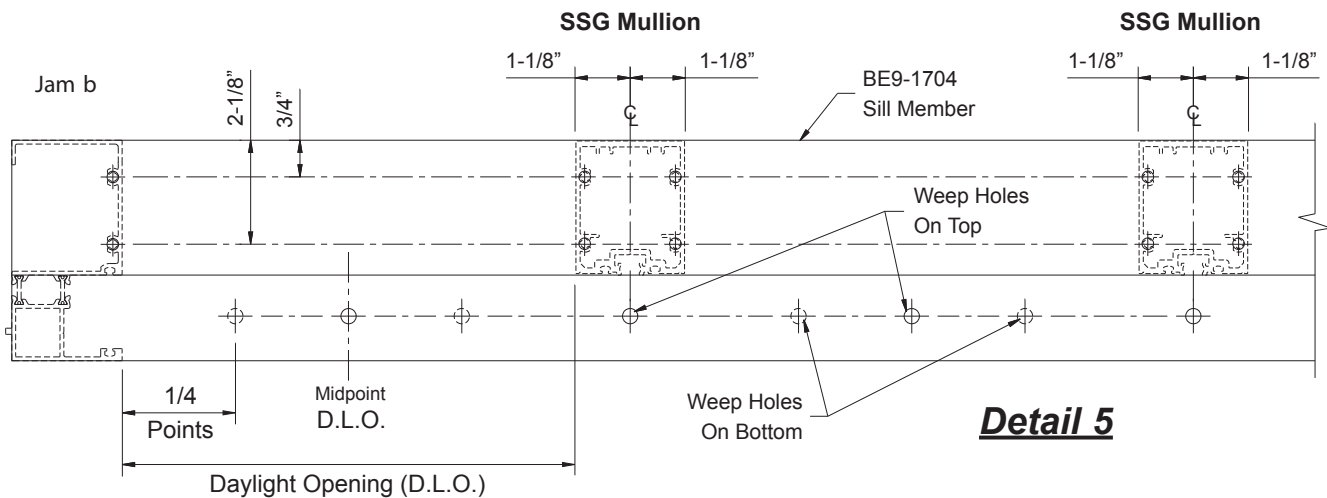

Detail 5

Continuous sill members must have weep holes drilled for each lite of glass.

-Mark the centerline of each intermediate mullion and the midpoint of D.L.O. between mullions in the glazing pocket of the sill.

-Turn the sill member over and mark the quarter points of D.L.O. between mullions on the bottom.

-Drill a 5/16" dia. hole at each hole location marked just in front of the thermal break.

See **Detail 6**.

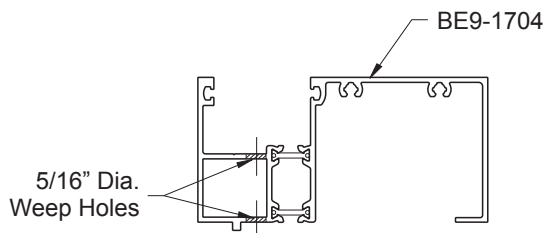

Detail 6

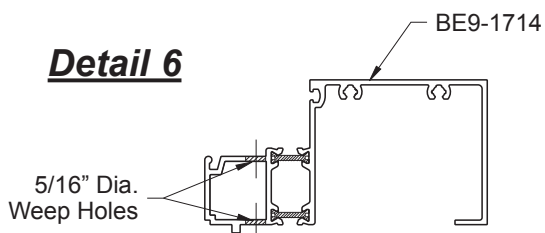

FRAME FABRICATION

**STEP 4
FABRICATE TWO PIECE MULLIONS & JAMB MEMBERS**

-Cut two piece mullions, fillers, and jamb members to the frame height determined in **Step 1** on **Page 6**.

Fabrication of Mullions for Inside Glazed Frames:

- Use a short piece of each horizontal member as a template.
- Center the template on the face of the mullion.
- Line up the glazing pockets and mark the location of each screw spline.

-OR-

-Layout the hole locations along the “V”-grooves of each member as shown in **Detail 7** for YWW 40 T or **Detail 8** for YWW 45 T.

-Drill a 0.236” (#B bit) diameter hole at each location marked.

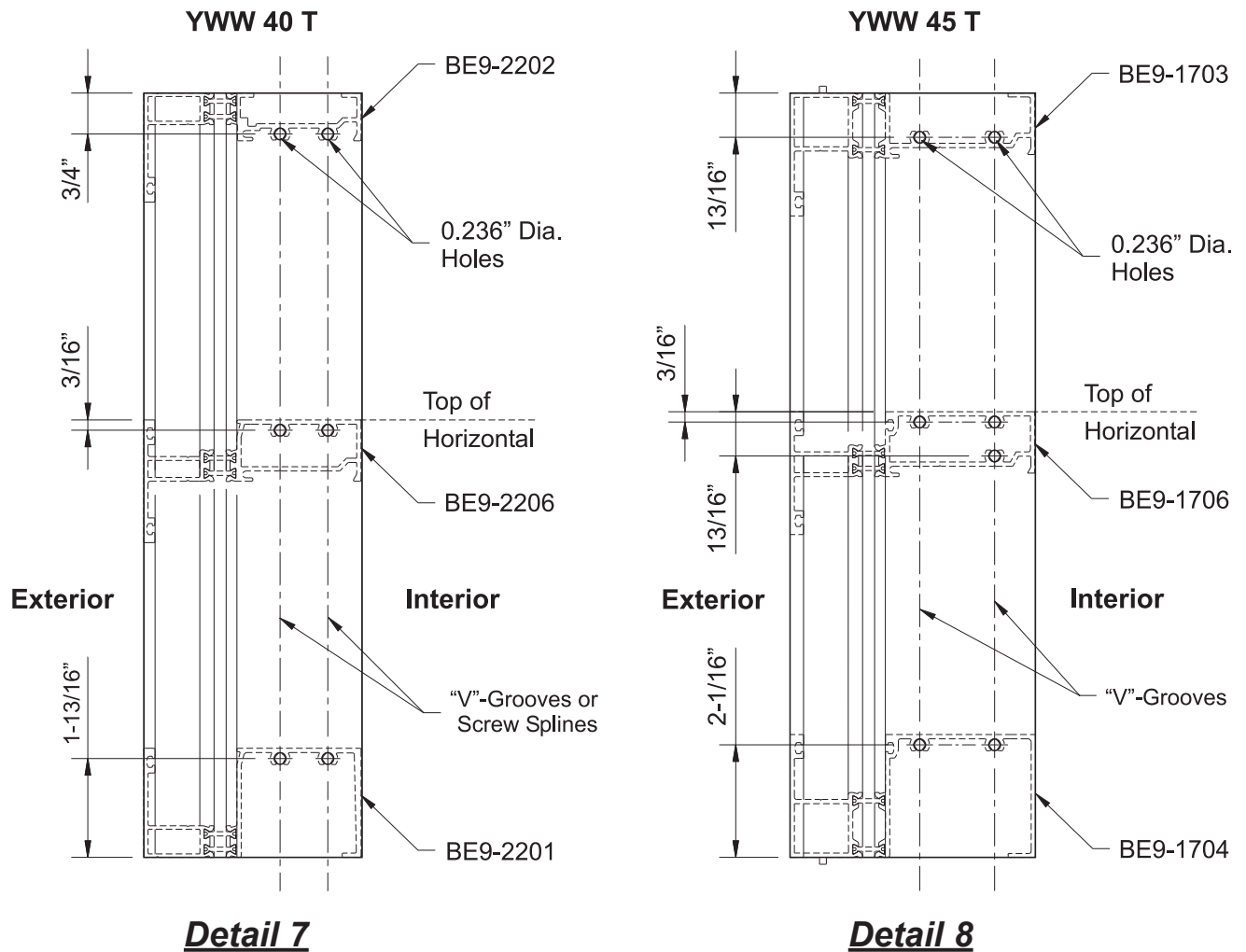

FRAME FABRICATION

STEP 4 (Continued) FABRICATE TWO PIECE MULLIONS & JAMB MEMBERS

Fabrication of Mullions for Outside Glazed:

Note: This option is only available for YWW 45 T.

- Use a short piece of each horizontal member as a template.
- Center the template on the face of the mullion.
- Line up the glazing pockets and mark the location of each screw spline.

-OR-

- Layout the hole locations along the "V"-grooves as shown in **Detail 9**.
- Drill a 0.236" (#B drill bit) diameter hole at each location marked.

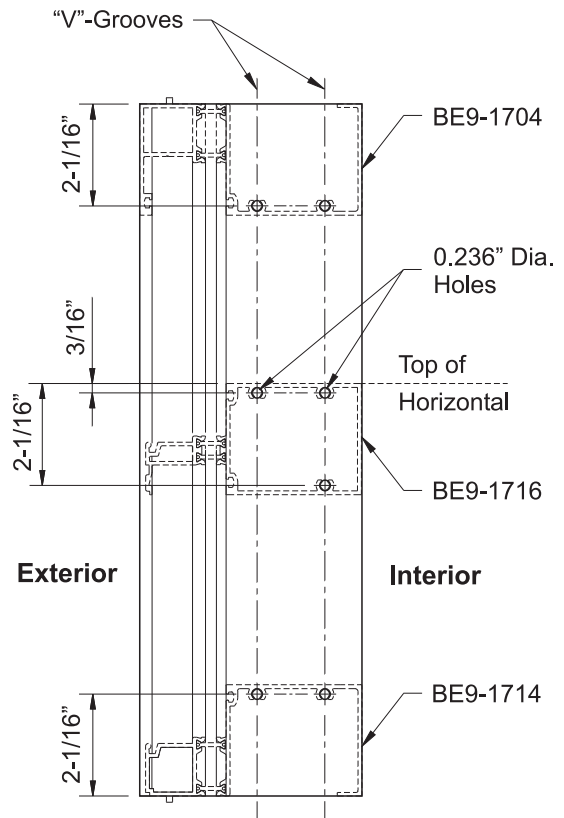

Detail 9

STEP 5 FABRICATE ONE PIECE SSG VERTICALS

- Cut one piece SSG mullions, E9-1723, to the daylight opening dimension between the head and sill members.

Intermediate horizontals are attached to the mullions using shear block, E1-1037. Fabricate one piece mullions to receive shear blocks:

- Refer to the shop drawings to determine the centerline of each intermediate horizontal.
- Mark a line on the mullion representing the centerline of each intermediate horizontal.
- Using a short piece of horizontal member with the shear block attached as a template, center the template on the face of the mullion.
- Line up the glazing pockets and mark the location of each screw spline.

-OR-

- Layout the hole locations as shown in **Detail 10**.

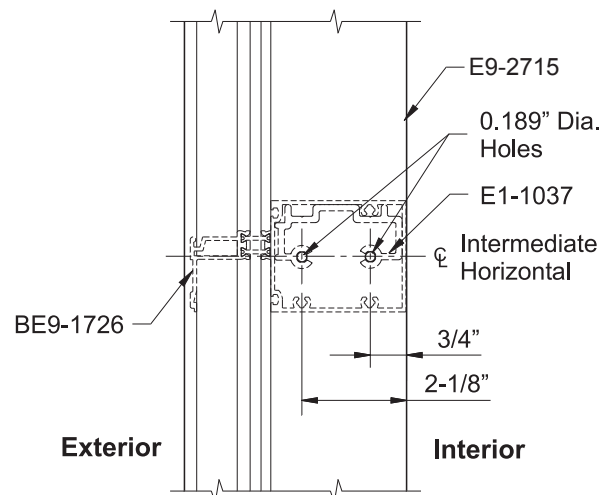

Detail 10

- Drill a 0.189" (#12 drill bit) diameter hole at each location marked.

FRAME FABRICATION

STEP 6

FABRICATE INTERMEDIATE HORIZONTAL MEMBERS

-Cut intermediate horizontals to the daylight opening dimension between verticals.

Intermediate horizontals that will be attached to one piece mullions require additional fabrication for the attachment of shear blocks:

- Layout hole locations on the top of the horizontal as shown in **Detail 11**.
- Drill a 0.236" (#B drill bit) diameter hole at each location marked.
- Countersink each hole to receive a FC-1212 (#12) fastener.

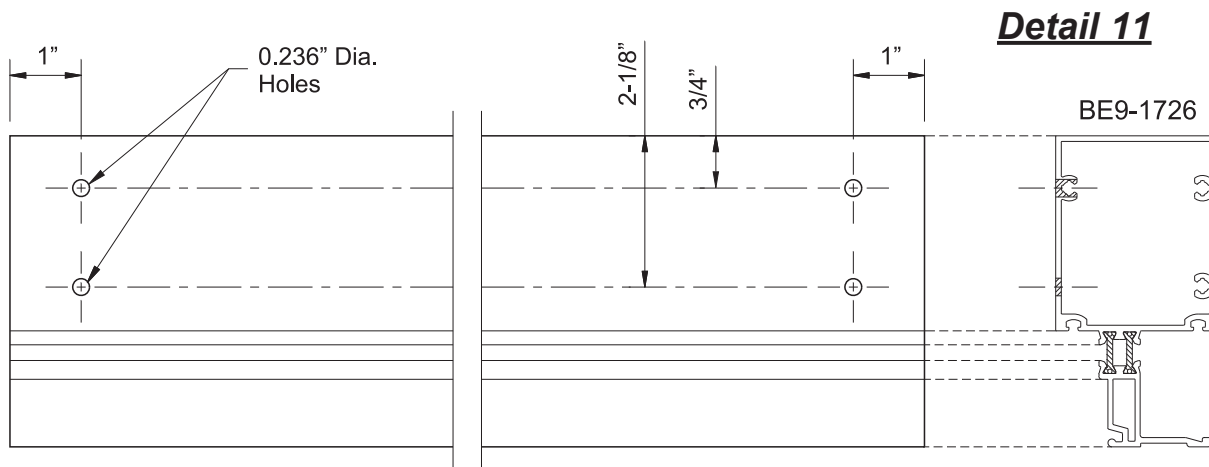

STEP 7

FABRICATE INTERIOR GLASS STOPS FOR INTERIOR GLAZED HORIZONTALS

Interior glazed horizontals require interior glass stops:

- BE9-1706 requires interior glass stop E9-1705.
- BE9-2206 requires interior glass stop E9-2204.

-Cut all interior glass stops to the same dimension as the horizontals minus(-) 1/32".

FRAME FABRICATION

STEP 8 FABRICATE EXTERIOR FACE COVERS

Exterior glazed and SSG horizontal and sill members require exterior face covers:

BE9-1716 and BE9-1714 require exterior face cover E9-1715.

BE9-1726, BE9-1750, and BE9-1740 require exterior face cover E9-1730.

Captured Glazing (face members on all four sides of the glass):

-Cut the face covers to the same dimension as the horizontal minus(-) 1/32".

Structural Silicone Glazing (SSG):

-For frame widths 24'-0" or less cut the face covers to the frame width minus 4-9/16".

-For frame widths greater than 24'-0" face members are spliced every ten to fifteen feet at the center of an intermediate vertical.

-Allow for a 1/32" joint at each jamb and a 3/8" joint between face cover splices.

Caution: DO NOT splice the face cover at an expansion mullion!

See **Detail 12**.

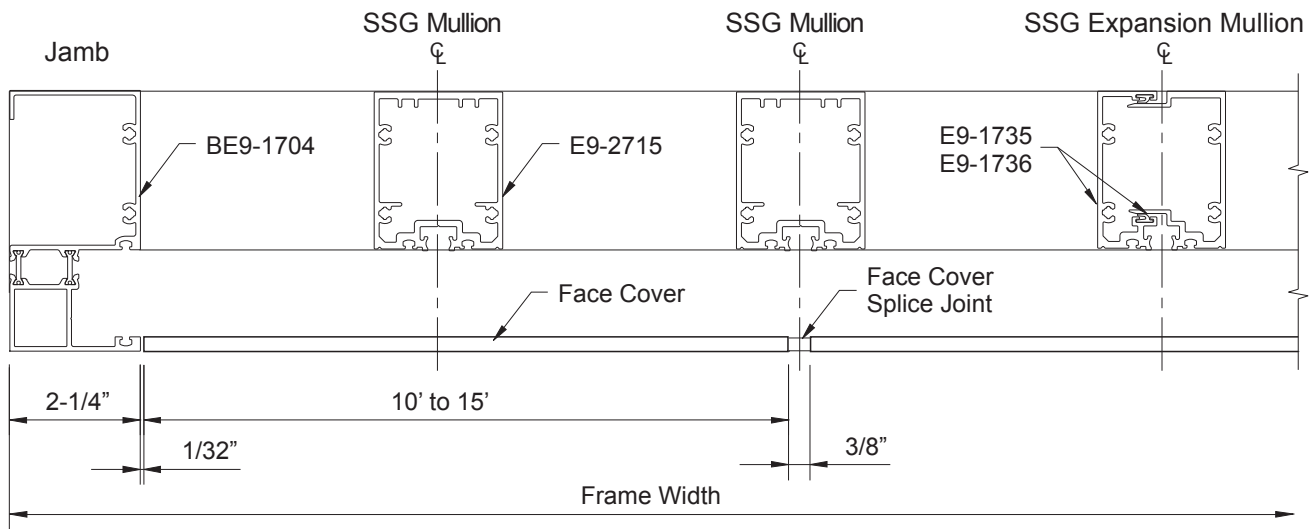

Detail 12

FRAME FABRICATION

**STEP 9
FABRICATE GLAZING ADAPTORS**

YWW 45 T offers glazing adaptors for 1/4" glazing:

- E9-1707 for captured mullion deep pockets.
- E9-1708 for captured mullion shallow pockets.
- E9-2716 for structural silicone glazed (SSG) mullions.
- E9-1725 for BE9-1709 pocket fillers for 90° corner posts and door jambs.

- Cut vertical glazing adaptors to the daylight opening dimension between horizontals plus(+) 7/8".
- Cut horizontal glazing adaptors to the daylight opening dimension between mullions minus(-) 1/32".

Glazing adaptor, E9-2716, requires additional fabrication:

- Mark hole locations along the recessed area in the middle of the adaptor 2" from each end and 12" on center.
- Drill 0.213" (#3 bit) dia. holes at each location marked.

See **Detail 13**.

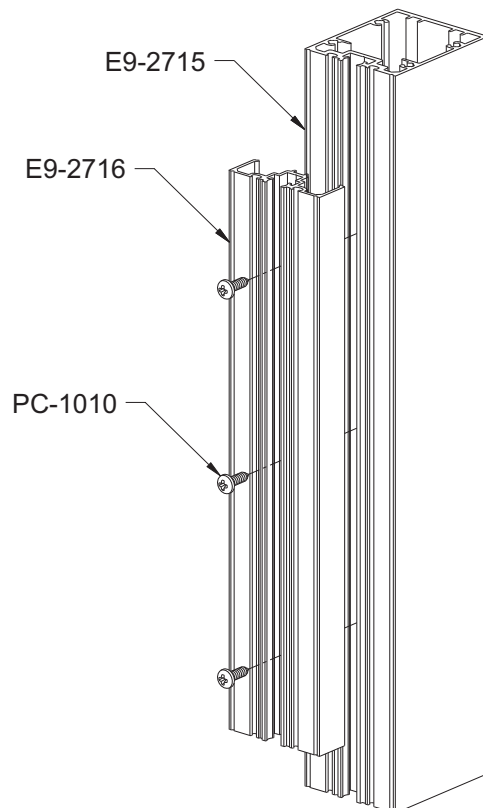

Detail 13

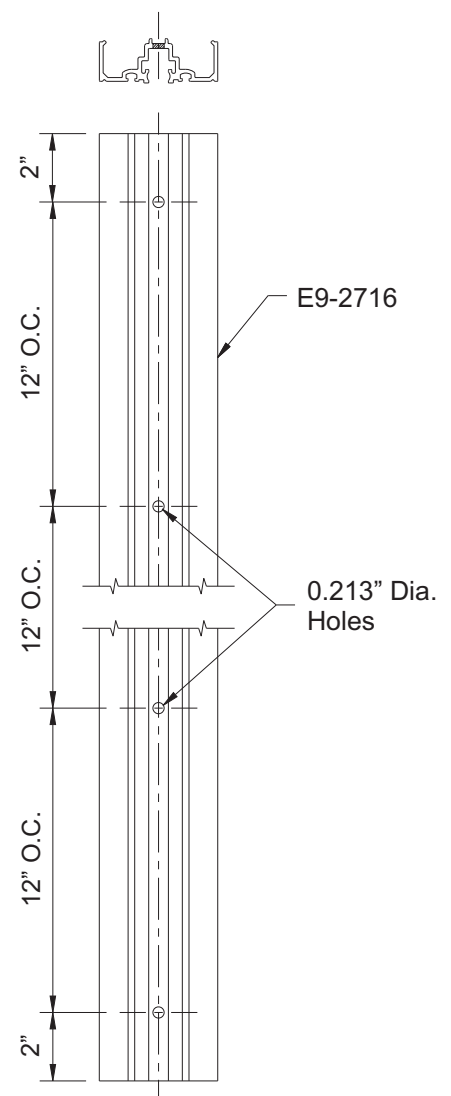

FRAME ASSEMBLY

STEP 10 ATTACH MULLION END CAPS

Mullion end caps are required at the top end only of jamb and mullions of vertical through frames and at each end of the expansion mullion of continuous head and sill frames.

-Clean the mullion ends and mullion end caps with a cleaner and method approved by the sealant manufacturer.

-Apply sealant to the gasket reglet and along the front of the mullions on both ends prior to installing mullion end caps, E3-0034. For expansion mullions, apply sealant to the fastener side mullion only.

-Attach the mullion end caps to each end of the mullion with fasteners as shown **Detail 14**.

-Tool the excess sealant along the inside of the glazing pocket between the mullion end cap and the mullion.

-Seal all screw heads.
See **Detail 14**.

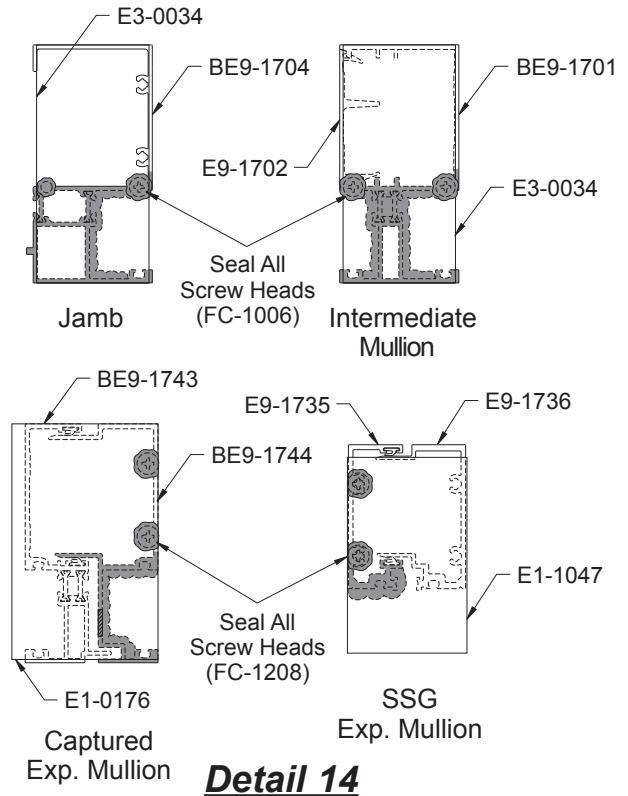

STEP 11 INSTALL END DAMS (For Continuous Head & Sill Frames Only)

The ends of head and sill members of continuous head & sill frames must be plugged using end dams, E2-0193 and E2-0194.

Use the following technique to install end dams at the head and sill:

- Clean the ends of the head and sill members with a cleaner and method approved by sealant manufacturer.
- Apply sealant to all contact sides of the end dam.
- Insert the end dam into each end, leaving it 1/8" recessed from the edge of the mullion.
- Apply sealant to the end dams and tool the sealant flush with the ends of the mullion.

See **Detail 15** (sill shown, head similar).

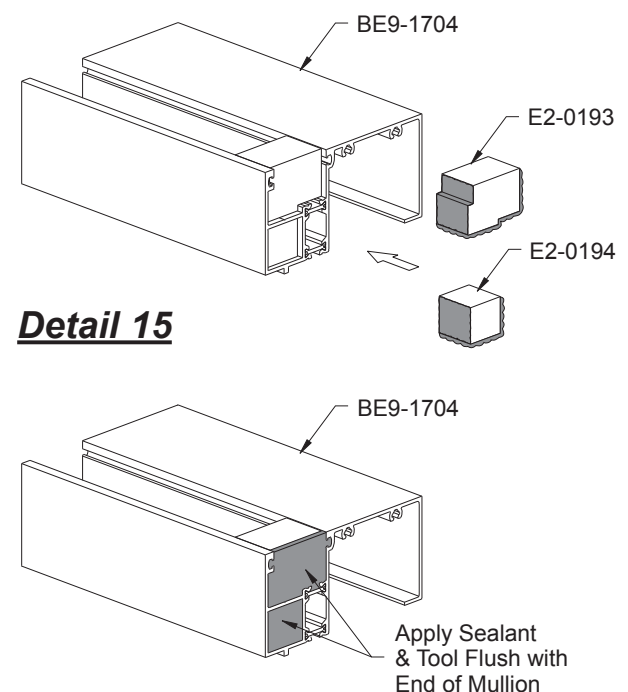

FRAME ASSEMBLY

STEP 12 ASSEMBLE FRAMES

Mullion Through Frames

- Clean the ends of horizontal members and attachment areas of vertical members using a cleaner approved by the sealant manufacturer.
- Apply sealant to both ends of head, horizontal, sill members just prior to assembly. Make sure that the sealant does not get into the glass stop reglets of the head and horizontal.
- Attach head and sill members to two-piece mullions and jambs with two (2) PC-1216 fasteners at each end.
- Attach intermediate horizontals to two-piece mullions and jambs with three (3) PC-1216 fasteners at each end.

Note: PC-1220 fasteners must be substituted for the PC-1216 fasteners when attaching to the mullions that have screw splines

- Using a clean cloth, wipe off the excess sealant while pushing it into the joints.

See **Detail 16**.

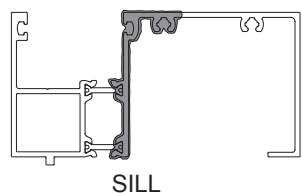
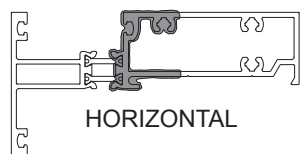
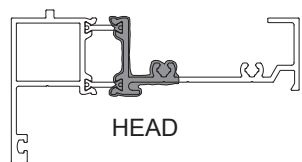

Apply sealant to the shaded areas at each end.

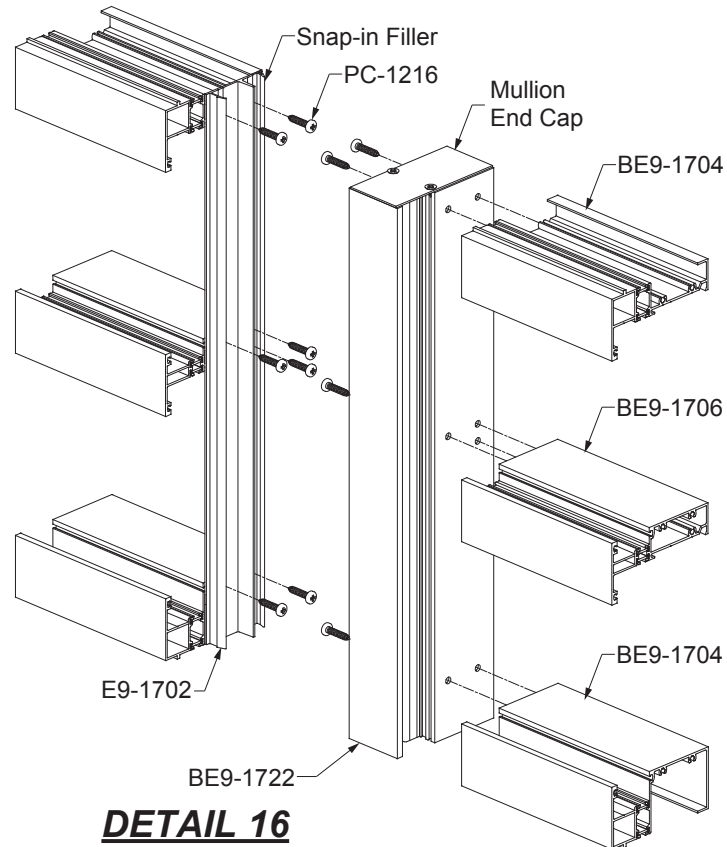

DETAIL 16
IG Shown
OG Similar

FRAME ASSEMBLY

STEP 12 ASSEMBLE FRAMES

Continuous Head & Sill Frames With One Piece SSG Mullions:

- Clean the ends of vertical members and attachment areas of head and sill members using a cleaner approved by the sealant manufacturer.
- Apply sealant to both ends of jamb and vertical members just prior to assembly.
- Note:** OG jamb members sun full frame height and attached similar to vertical through frames.
- Attach jamb members to continuous head and sill members using (2) PC-1220 fasteners at each end
- Attach one piece mullions to continuous head and sill members using (4) PC-1220 fasteners at each end.
- Apply sealant to both ends of intermediate horizontal members just prior to assembly. Make sure that the sealant does not get into the glass stop reglets of the horizontal.
- Attach intermediate horizontals to shear block, E1-1037, using (2) FC-1212 fasteners at each end.
- Using a clean cloth, wipe off the excess sealant while pushing it into the joints.

See **Detail 17**.

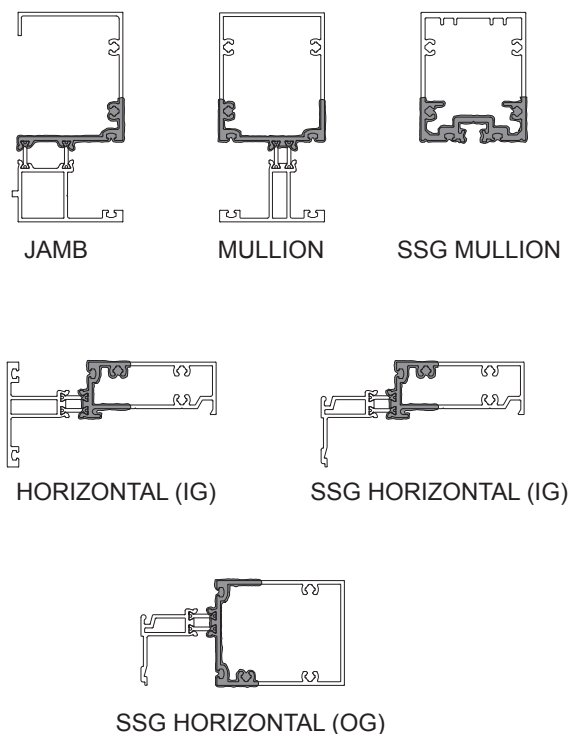

SSG HORIZONTAL (OG)
Apply sealant to the shaded areas at each end.

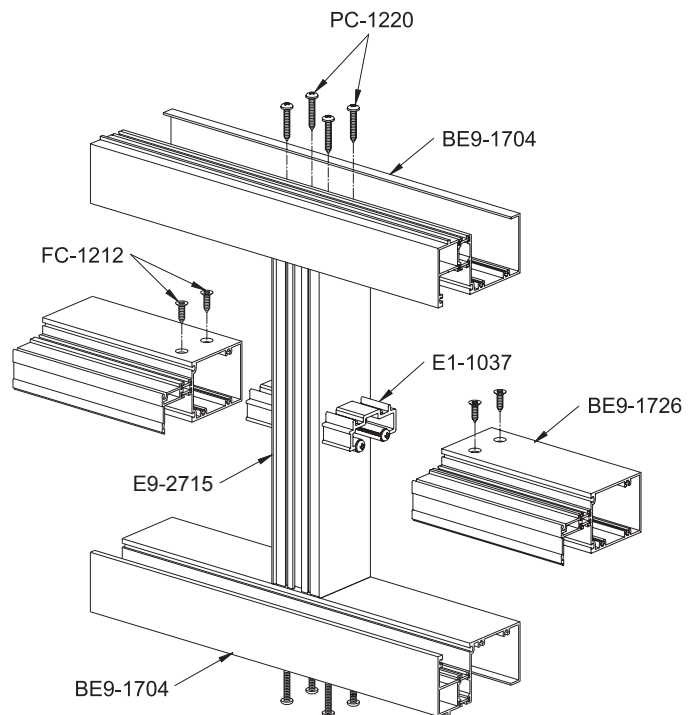

Detail 17

FRAME INSTALLATION

STEP 13
INSTALL SILL FLASHING

- Clean all joint surfaces using cleaner approved by sealant manufacturer.
- Install brake metal end dam, E1-0168, at each end of the sill flashing.
- Apply and tool sealant along the joint between the end dam and the sill flashing.
Tape down the back corners to hold the end dam in place until the sealant cures.
- Starting at the smallest opening height, install the sill flashing with a minimum of 1/4" shim underneath. Sill flashing must be installed level.
- Anchor the sill flashing to the structure a maximum of 4" from each end and then 18" to 24" on center. Alternate the anchors from front to back.
- Apply and tool sealant to the heads of all fasteners.

The sill flashing must be spliced every twelve to fifteen feet using splice sleeve, E1-0174:

- Apply bond breaker tape to center of the splice sleeve on the underside.
- Apply a generous amount of sealant to both sides of the sill flashing splice.
- Center the splice sleeve over the 3/8" splice joint.
- Tool the sealant up and over the edges of the splice sleeve to completely seal the joint.
- Apply and tool sealant at the front and back faces of the splice joint.

See **Detail 18**.

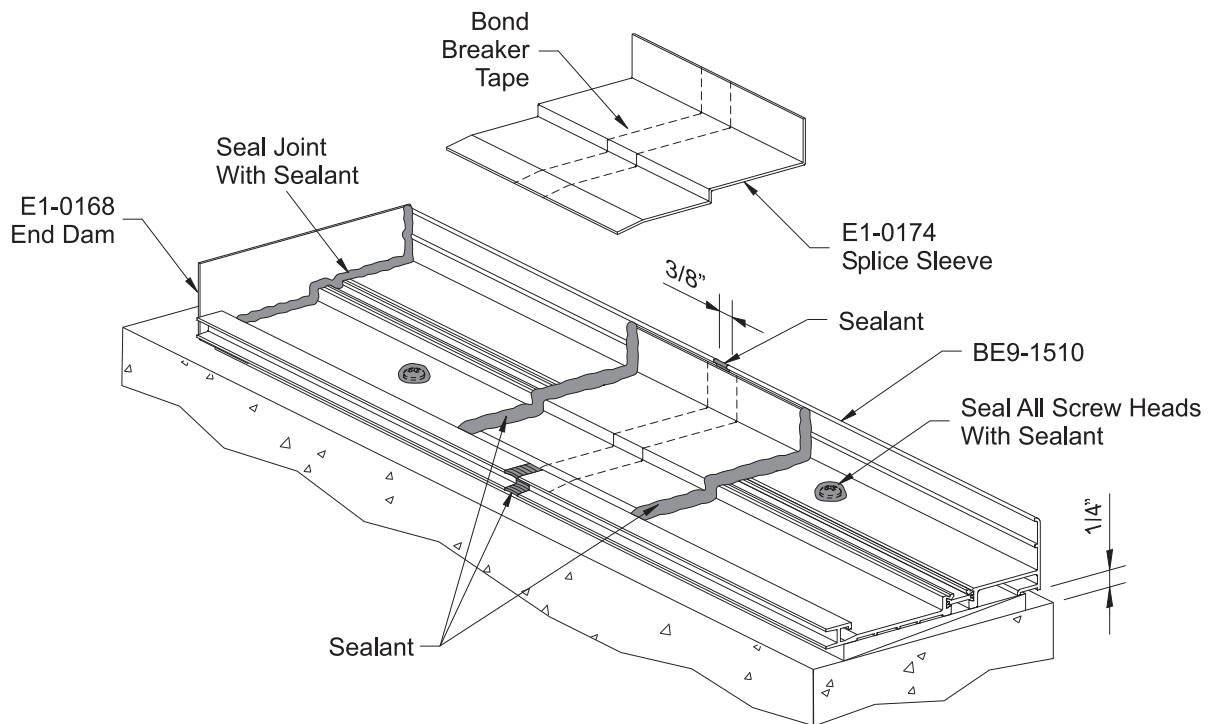

DETAIL 18

YWW 45 T Shown
YWW 40 T Similar

FRAME INSTALLATION

STEP 14 INSTALL ASSEMBLED FRAMES

- Immediately before installing the frames, apply a continuous bead of sealant to the back leg of the sill flashing, and a generous amount of sealant to the pilot holes in the sill flashing. Be sure not to obstruct weep holes on exterior of sill. Make sure all surfaces are clean before applying sealant.
- Snap frame assemblies together and set onto the sill flashing.
- Shim the head and jamb members to ensure that the frame is installed plumb, square, and true.
- Anchor the head members at 6" on each side of every vertical centerline and then no more than 24" on center.
- Anchor jamb members 6" from each end and then no more than 24" on center.
- Follow by inserting and tightening fasteners into flashing through sealant.
- Sill members for YWW 40 T, BE9-2201, must be attached to the sill flashing with a PM-1014-SS fastener at each hole previously drilled during sill fabrication.
- Seal all anchor heads.

Note: Shims must be installed at all anchor locations.

See **Detail 19**.

(Inside glazed shown, outside glazed similar)

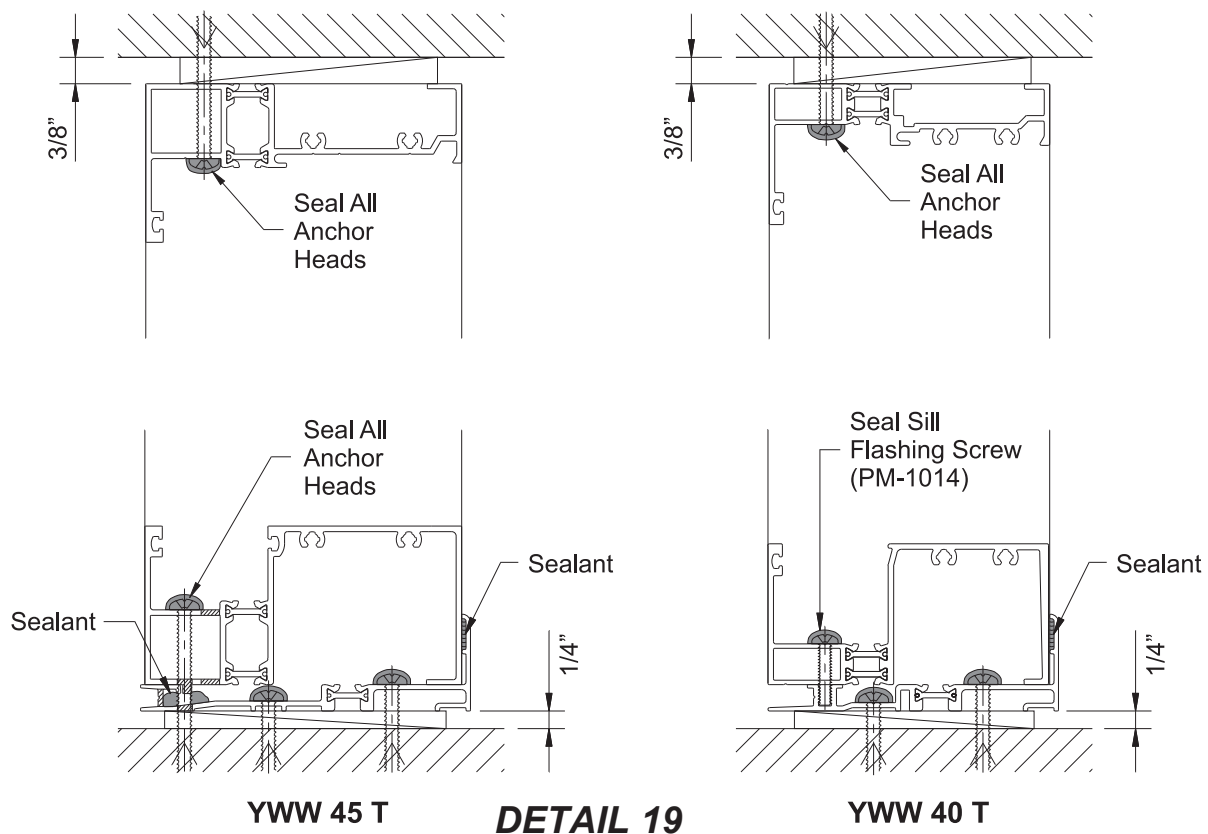

FRAME INSTALLATION

**STEP 15
APPLY INTERNAL & PERIMETER SEALANT**

- Apply sealant to all vertical/horizontal joints at the glazing pockets.
 - Tool the sealant to ensure a watertight joint.
- See **Detail 20**.

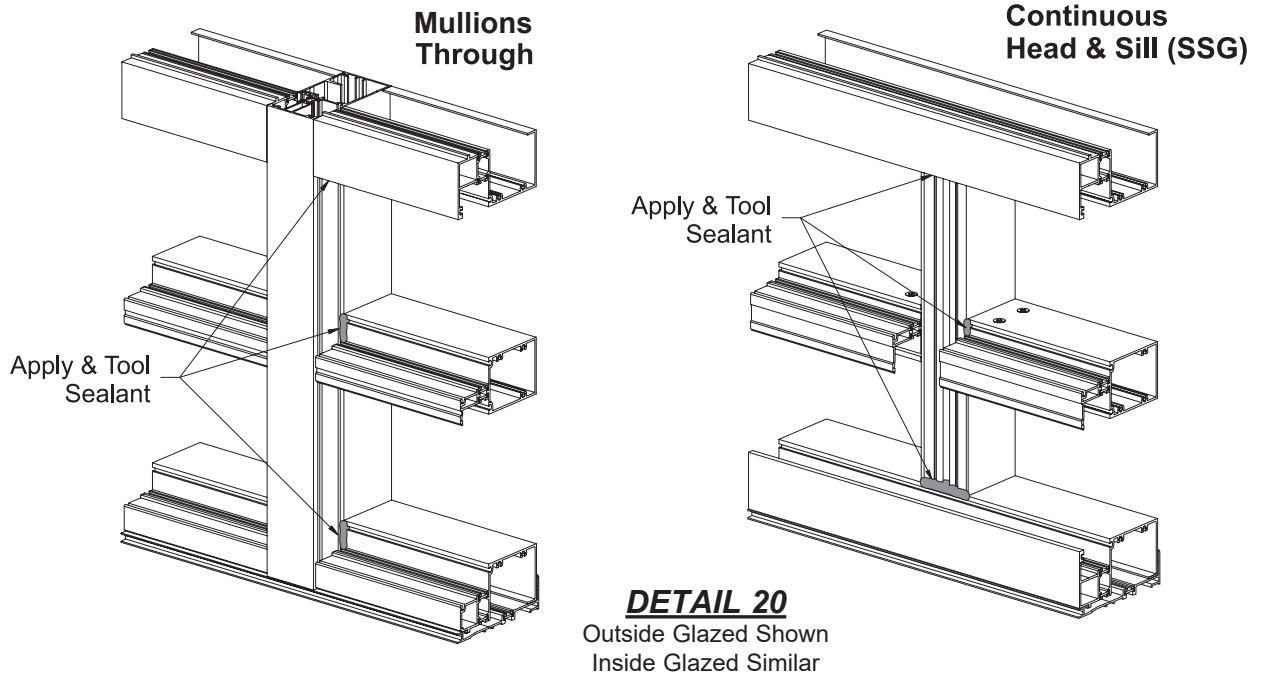

- Install backer rod around the perimeter of the frame between the frame and the structure.
 - Apply perimeter sealant and tool the sealant to ensure a watertight joint.
- See **Detail 21**.

Note: Interior perimeter seal must be applied to ensure YKK tested water infiltration performance.

DETAIL 21
Inside Glazed Shown
Outside Glazed Similar

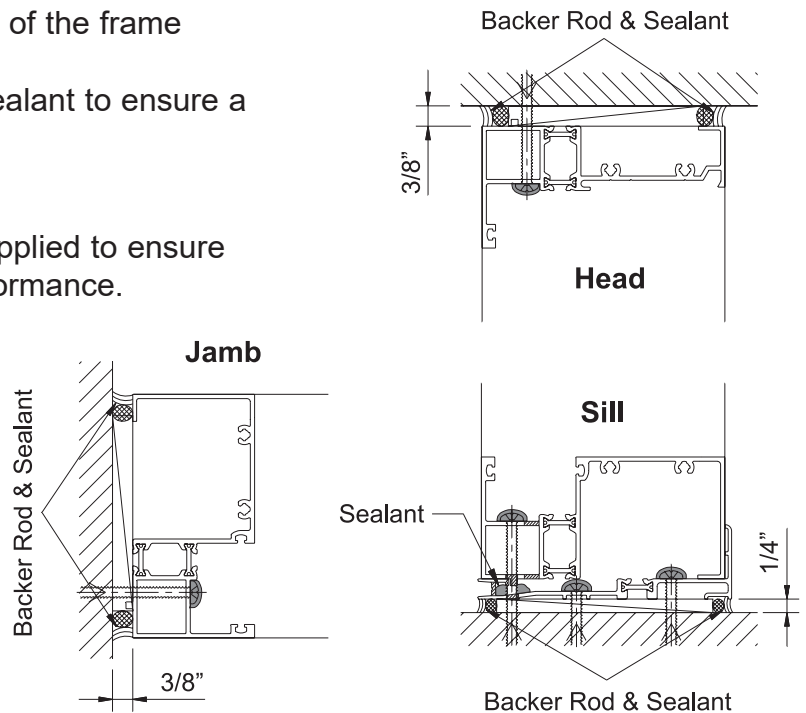

FRAME INSTALLATION

STEP 16 INSTALL WATER DEFLECTORS (Standard Mullions and Jambes)

The installation of a water deflector, E2-0047, at the ends of every intermediate horizontal is required to divert water away from the insulated units.

- Clean and dry off the glazing pocket of each horizontal at the ends.
- Peel off the protective paper and install the water deflector at the end of the horizontal.
- Position the vertical leg of the deflector against the end of the horizontal.
- Apply and tool sealant along the edges of the water deflector down onto the horizontal.
- Seal the ramp of the water deflector to the sides of the glazing pocket wall.

See **Detail 22**.

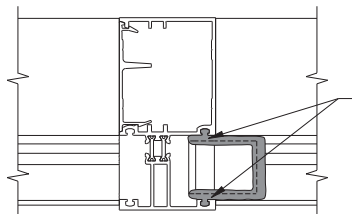

Seal Ramp of Deflector to the Pocket Wall

DETAIL 22

Outside Glazed Shown
Inside Glazed Similar

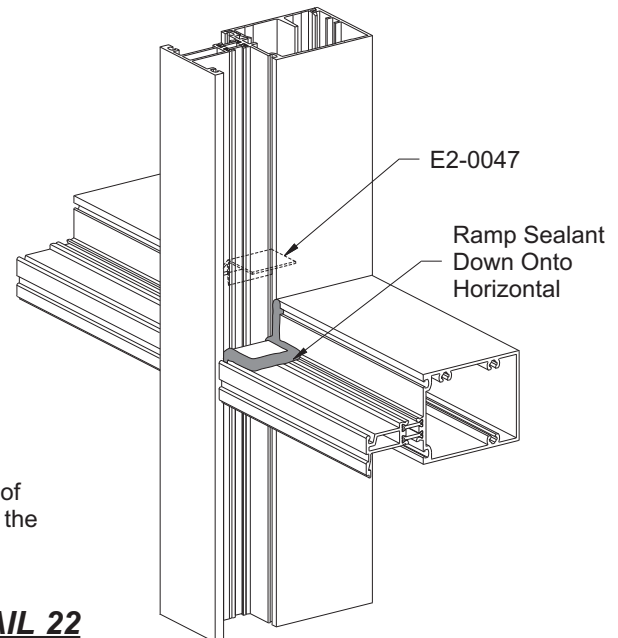

STEP 17 INSTALL HORIZONTAL BRIDGES (For SSG Mullions Only)

The installation of horizontal bridge, E1-1038, is required to bridge the gap between intermediate horizontals at the SSG vertical.

- Clean and dry off the glazing pocket of each horizontal at the ends.
- Install E1-1038 from the underside of the horizontals with a PC-1006 fastener on each side.
- Fill the cavity of the horizontal with backer rod and completely cover the end of the horizontals with sealant.
- Apply and tool sealant at all bridge to horizontal and vertical joints to ensure a watertight seal.

See **Detail 23**.

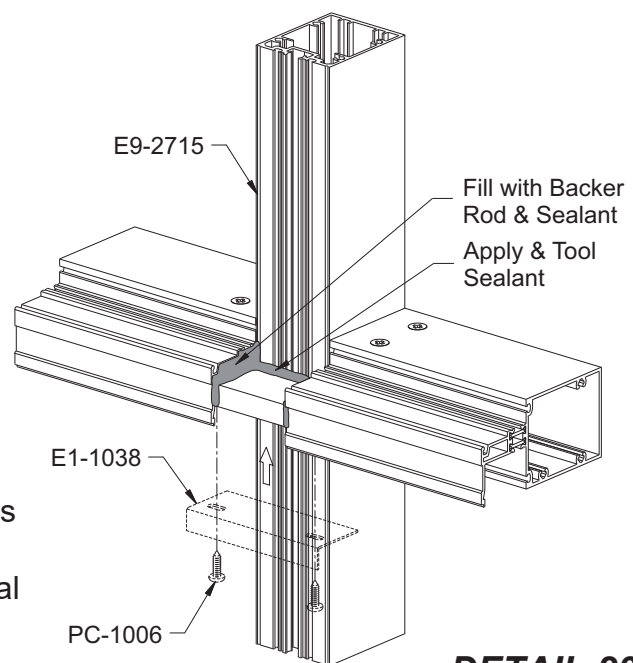

DETAIL 23

FRAME INSTALLATION

**STEP 18
INSTALL 1/4" GLAZING ADAPTORS
(When Required)**

Attach the vertical glazing adaptors first.

For Standard Mullions:

- Apply sealant in the vertical gasket reglets.
- Center the vertical adaptor in the opening.
- Position the foot of the adaptor into the MegaTherm recess and rotate the other end into the gasket reglet of the mullion.

For SSG Mullions:

- Center the vertical adaptor in the opening.
- Attach the SSG glazing adaptor, E9-2716, to the mullion with PC-1010 fasteners, 2" from each end and no more than 18" on center.
- Seal all screw heads.

See **Detail 24**.

Attach the horizontal glazing adaptors last.

- Apply sealant to the ends of the horizontal glazing adaptors.
- Install the horizontal adaptors.

-Tool the sealant at the intersections of the adaptors to completely seal the joint.

See **Detail 25**.

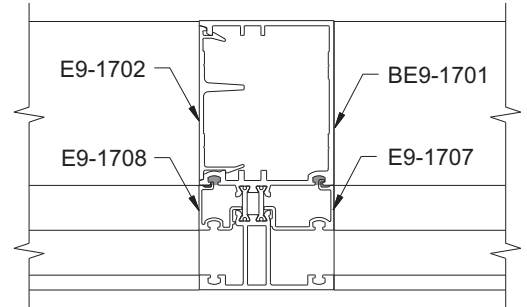

Standard Vertical

DETAIL 24

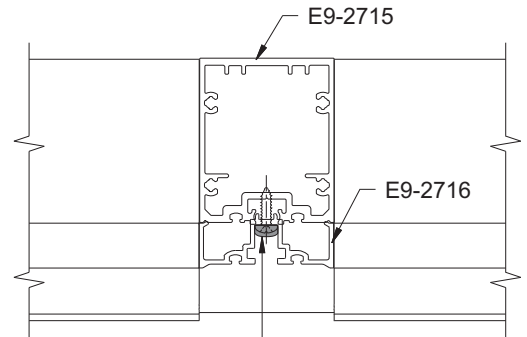

SSG Vertical

Seal All
Screw Heads
(PC-1010)

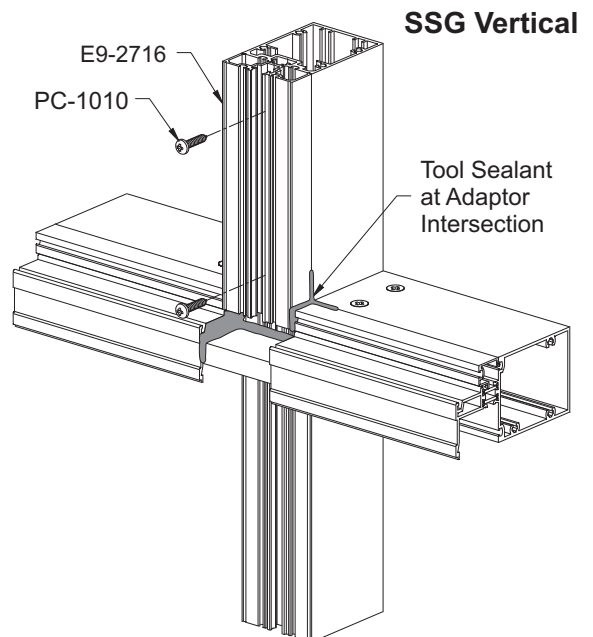
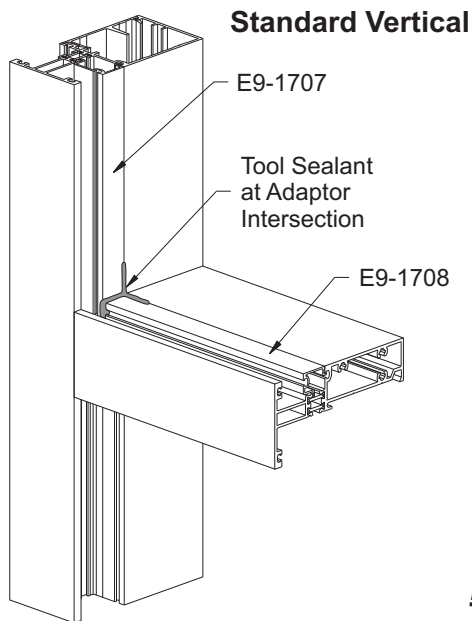

DETAIL 25

GLAZING

STEP 19 INSTALL GLAZING GASKETS

For inside glazing: Push-in gasket, E2-0801, must be installed on the exterior prior to glazing.
For outside glazing: Push-in gasket, E2-0801, must be installed on the interior prior to glazing.

-Using a small brush clean out any dirt that may have accumulated in the gasket reglets.

Vertical glazing gaskets must be installed first:

- Cut vertical glazing gaskets to the Daylight Opening plus(+) 3/4" plus(+) 1/4" for each foot of length.
- Insert the gasket into the reglets at each end first; then insert the gasket at the midpoint of the opening.
- Push the gasket into the reglet starting at the midpoint and work towards each end.

See **Detail 26**.

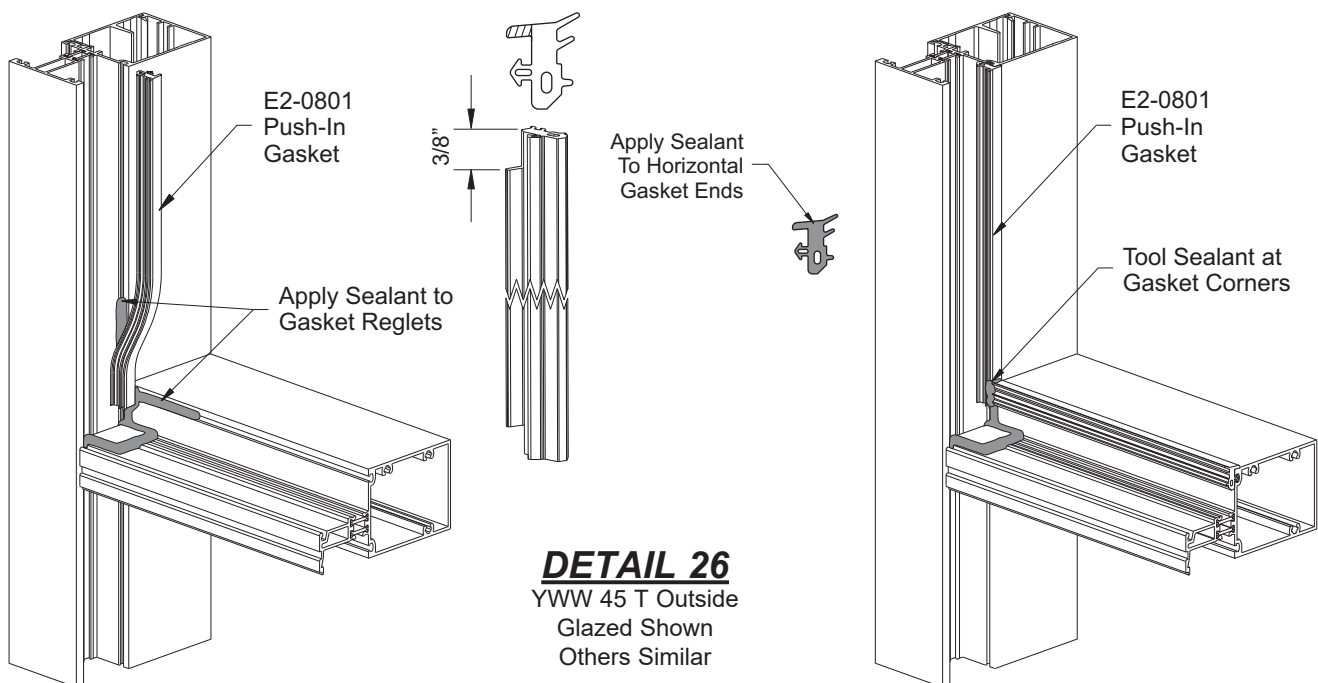

Install horizontal glazing gaskets next:

- Cut horizontal glazing gaskets to Daylight Opening plus(+) 1/4" for each foot of length.
- Apply sealant to each end of the horizontal glazing gasket prior to inserting into the reglet.
- Insert the gasket into the reglet at each end first; then insert the gasket at the midpoint of the opening.
- Push the gasket into the reglet starting at the midpoint and work towards each end.

-Tool the excess sealant at the gasket corners to ensure a watertight seal.

See **Detail 26**.

GLAZING

STEP 20
INSTALL GLASS FOR STANDARD GLAZING

Determine the glass size:

	Width	Height
Standard Glazing	D.L.O. + 7/8"	D.L.O. + 7/8"

- Install setting blocks at 1/4 points or according to engineering calculations.
At intermediate horizontals: E2-0184 for 1" glazing and E2-0192 for 1/4" glazing.
At sill conditions: E2-0182 for 1" glazing and E2-0190 for 1/4" glazing for YWW 45 T.
E2-0228 for 1" glazing for YWW 40 T.

See **Detail 27**.

- Install side blocks, E2-0186, in the shallow glazing pocket of each vertical at the midpoint of daylight opening.
- Install anti-walk blocks, E2-0153, in the glazing pocket of the jambs.
- Carefully install glass into the frame making sure that setting and side blocks are properly aligned with the glass.

Note: Be careful not to disengage any gaskets that have already been installed when installing glass.

See **Details 27 & 28**.

DETAIL 27

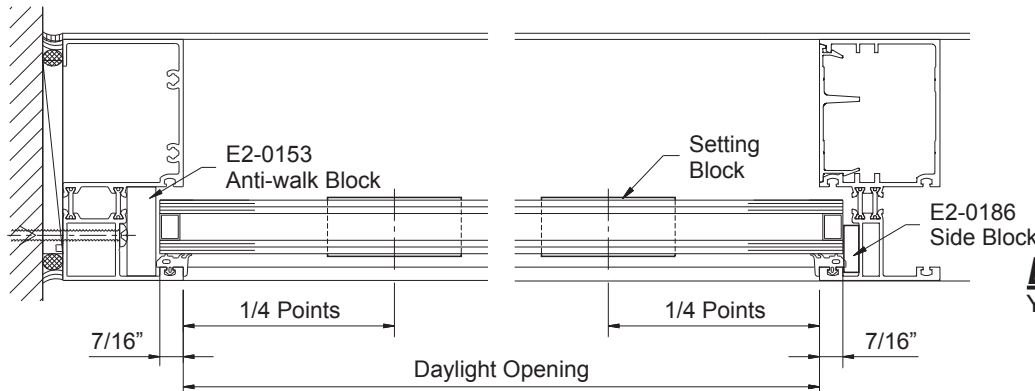
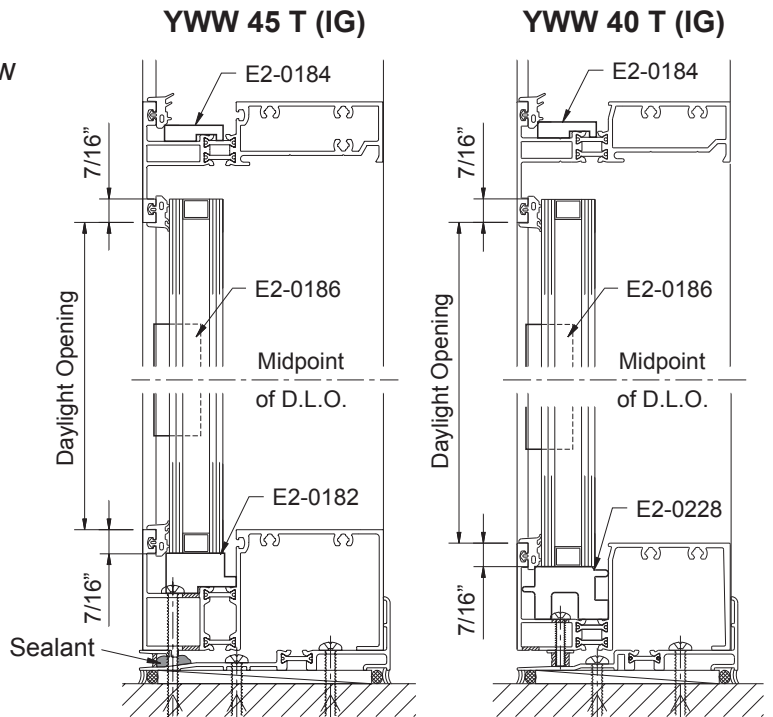

DETAIL 28
YWW 45 T Inside
Glazed Shown
Others Similar

GLAZING

**STEP 20 (Continued)
INSTALL ANTI-WALK BLOCKS**

Anti-walk blocks must be installed in the vertical deep glazing pocket of each lite centered along the daylight opening:

- E2-0153 for all jambs.
- E2-0153 for standard verticals.
- E2-0153 for expansion mullions.

-Flatten the anti-walk block against the surface of the glass and push it into the opening between glass and the mullion until it is released into the glazing pocket.

See **Details 29 & 30**.

Note: Anti-walk block installation for inside glazing shown below; installation for outside glazing is similar but installed from the outside.

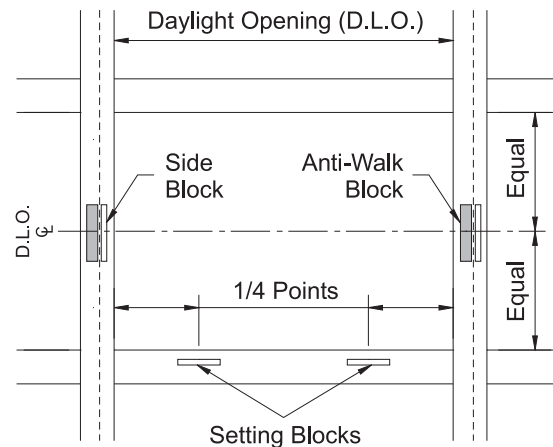

DETAIL 29

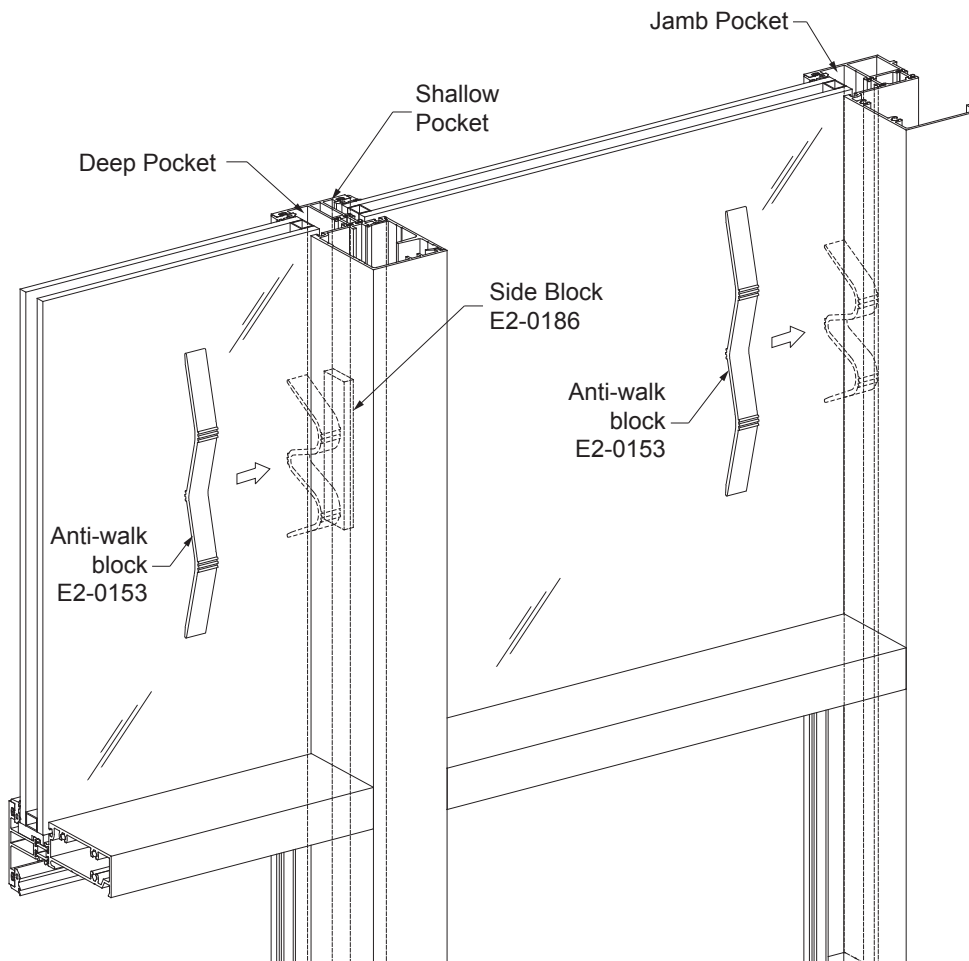

DETAIL 30
IG Shown
OG Similar

GLAZING

STEP 20 (Continued) INSTALL GLASS FOR STANDARD GLAZING

For Interior Glazing:

Interior glass stops are required at all head and intermediate horizontals:

YWW 45 T: E9-1705 for 1" glazing and E9-1713 for 1/4" glazing.

YWW 40 T: E9-2204 for 1" glazing.

- Apply sealant to each end of the glass stops and snap them into position.
- Tool the sealant into the joint between the glass stop and the mullion to ensure a watertight seal and wipe away any excess sealant.

See **Detail 31**.

- Install the interior wedge gaskets, E2-0808 using the same technique described in **Step 19**.

Note: Always install vertical glazing gaskets first. Seal the ends of the horizontal gaskets into the vertical gaskets.

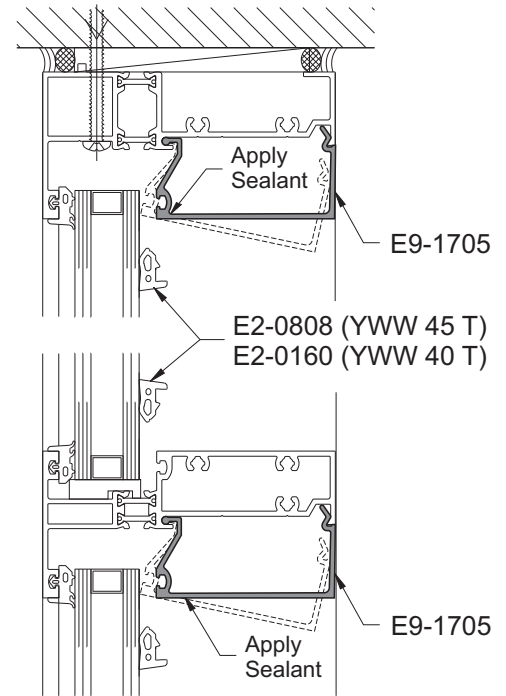

DETAIL 31

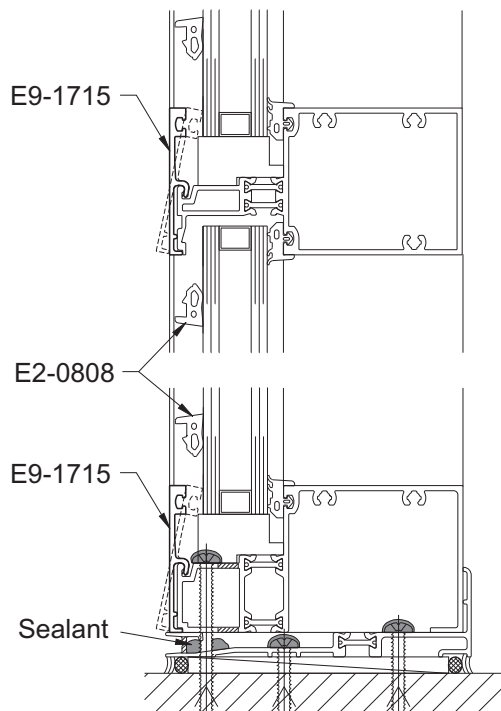

DETAIL 32

For Outside Glazing:

Exterior face covers are required at all sill and intermediate horizontals:

E9-1730 for BE9-1726, BE9-1740, & BE9-1750 horizontal members.

E9-1715 for BE9-1714 horizontal members.

- Engage the hook of the face covers with the ball of the horizontal members and rotate them into position.

See **Detail 32**.

- Install the exterior wedge gaskets, E2-0808 for (YWW 45 T), or E2-0160 (YWW 40 T), using the same technique described in **Step 19**.

Note: Always install vertical glazing gaskets first. Seal the ends of the horizontal gaskets into the vertical gaskets.

GLAZING

STEP 21 INSTALL GLASS FOR STRUCTURAL SILICONE GLAZING

Determine the glass size:

	Width	Height
Jamb to SSG	D.L.O. + 1-5/16"	D.L.O. + 7/8"
SSG to SSG	D.L.O. + 1-3/4"	D.L.O. + 7/8"

- Install setting blocks at 1/4 points or according to engineering calculations.
At intermediate horizontals: E2-0184 for 1" glazing and E2-0192 for 1/4" glazing.
At sill conditions: E2-0182 for 1" glazing and E2-0190 for 1/4" glazing.

See **Detail 33**.

- Cut glazing spacer, E2-0544, to the same vertical dimension as the glass plus(+) 1/4" per foot of length.
- Install the glazing spacer centered along the vertical opening.
- Install the interior glazing gaskets at the jambs and horizontals as shown in **Step 19** on **Page 24**.
- Carefully install each lite of glass leaving a 1/2" joint between lites of glass. Be careful not to disturb the interior gaskets and spacers.
- Insert the temporary glass retainers, E3-0001 for 1" glazing or E3-0006 for 1/4" glazing, between the lites and twist them 90° clockwise to engage.
- Locate temporary glass retainers 18" to 24" on center.
- Snap on exterior face covers and install exterior wedge gaskets, E2-0542, starting at one end and work towards the opposite end.

See **Detail 34**.

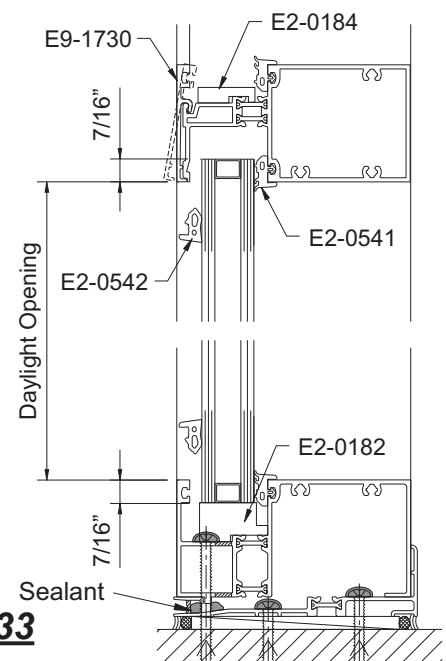

DETAIL 33

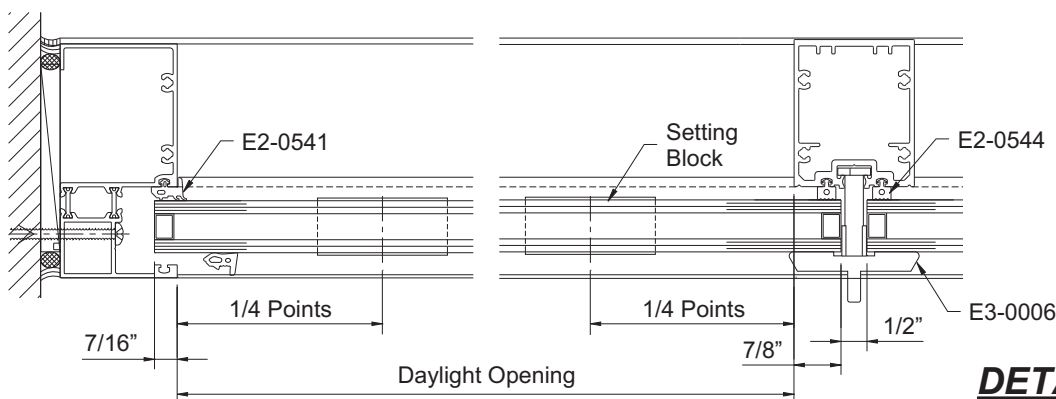

DETAIL 34

GLAZING

STEP 21 (Continued)

INSTALL GLASS FOR STRUCTURAL SILICONE GLAZING

Apply Interior Structural Silicone:

- Run masking tape vertically on the glass with one edge in line with the side of the mullion.
- Run another piece of masking tape vertically along the edge of the vertical next to the glass.
- Prior to applying structural silicone, clean all contact surfaces using an approved cleaner.

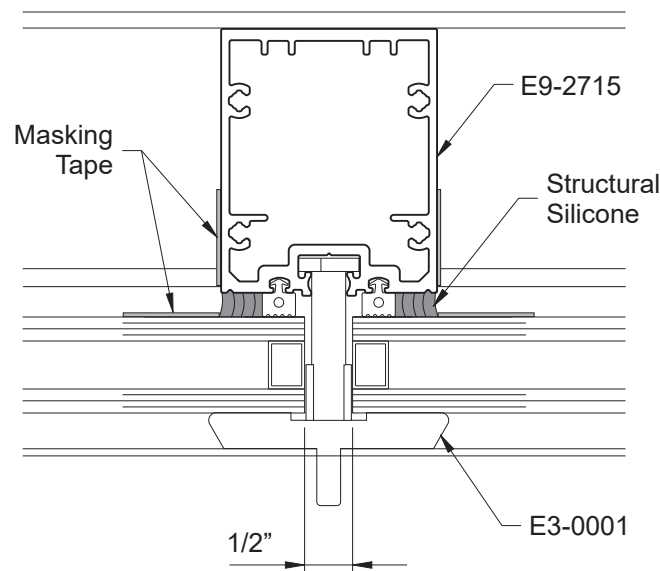

DETAIL 35

- Apply an approved structural silicone from the bottom to the top of the joint. Use positive pressure to completely fill the cavity between the glass and vertical mullion.
 - Using a nylon spatula or other non-scratching implement, tool the silicone immediately after running the vertical joint. Exert positive pressure while tooling to ensure that the silicone completely fills the cavity.
 - Be careful not to remove too much silicone. The silicone should make complete contact with the glass and aluminum surfaces. The finished joint should be flush with the edge of the vertical.
- See **Detail 35**.

Caution: Do not permit the silicone to skin over before it is tooled. Immediately remove masking tape after tooling the silicone.

GLAZING

STEP 21 (Continued) INSTALL GLASS FOR STRUCTURAL SILICONE GLAZING

Apply Exterior Weatherseal:

Once the interior structural silicone has cured, it is necessary to seal the 1/2" wide exterior joint between the lites of glass. Please consult sealant manufacturer for recommended cure time.

- Remove the temporary glass retainers and insert an approved, open cell polyurethane backer rod between the lites of glass.
- Clean all contact surfaces with an approved cleaner and apply masking tape to both vertical edges of the glass.
- Starting at the bottom of the lite, pump an approved structural silicone into the joint between the lites of glass. Apply moderate pressure so that the void is completely filled.

Caution: Be careful not to puncture the backer rod or push it out of the way.

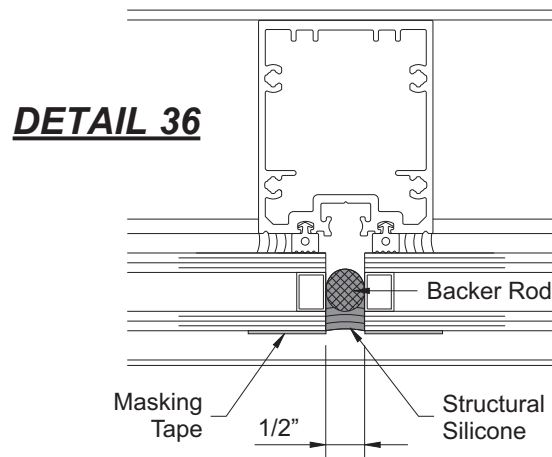

See **Detail 36**.

- At face cover splices, carry the sealant down over the face cover without sealing off the bottom to allow the system to weep properly.

See **Detail 37**.

- Using a nylon spatula or other non-scratching implement, tool the silicone immediately after running the vertical joint. Exert positive pressure while tooling to ensure that the silicone completely fills the cavity.
- Be careful not to remove too much silicone. The silicone should make complete contact with the glass and aluminum surfaces. The finished joint should be flush with the edge of the vertical.

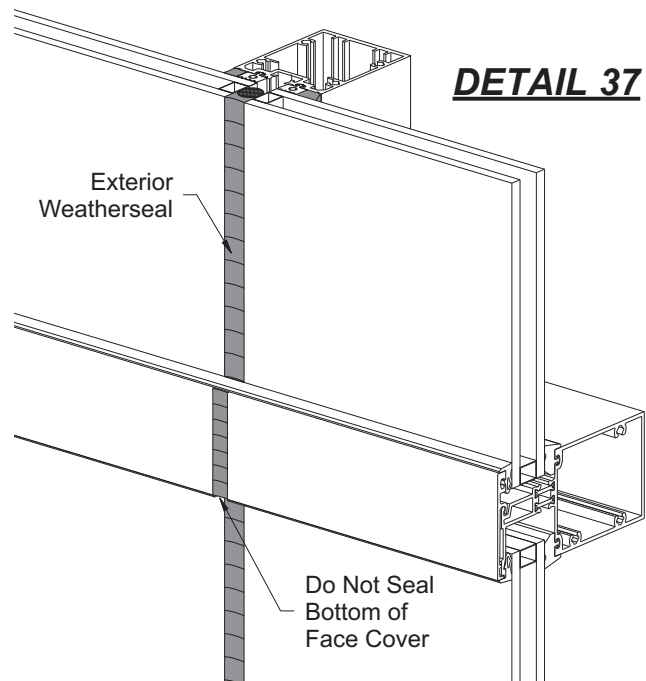

Caution: Do not permit the silicone to skin over before it is tooled. Immediately remove masking tape after tooling the silicone.

DOOR FRAME INSTALLATION

**STEP 22
INSTALL DOOR FRAME**

Doors are shipped assembled, and door frames will be fabricated and shipped knocked down. Please refer to the 20D, 35D, & 50D Entrances Installation Manual for door installation.

Prior to snapping the assembled frames into the door jamb, the end of the sill flashing needs to be sealed to the door jamb.

- Apply and tool sealant to all sill flashing to door jamb joints.
- Apply sealant to completely fill the door jamb cavity and ramp the sealant down onto the sill flashing.

See **Detail 38**.

Glass sizes for transom areas are not the same as for standard YWW 45 T frames. See the table below and **Detail 39** for transom glass sizes.

Transom Glass Sizes:

	Width	Height
Transom Glazing	D.L.O. - 1/8"	D.L.O. + 7/8"

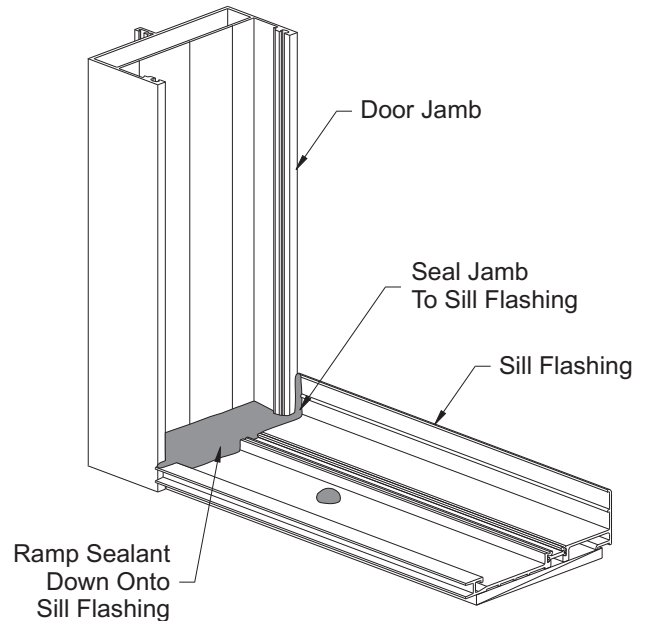

DETAIL 38

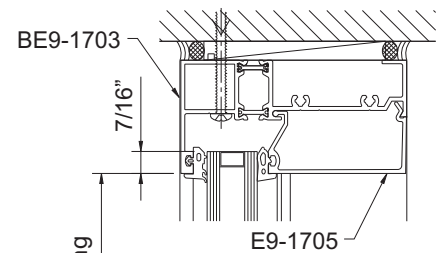

DETAIL 39

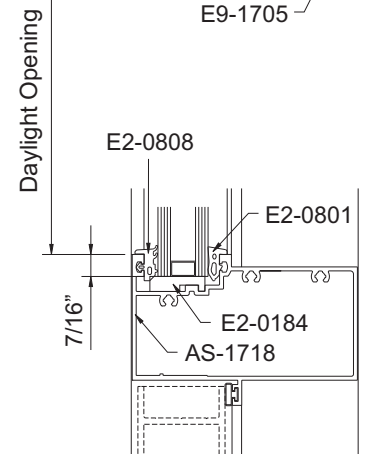
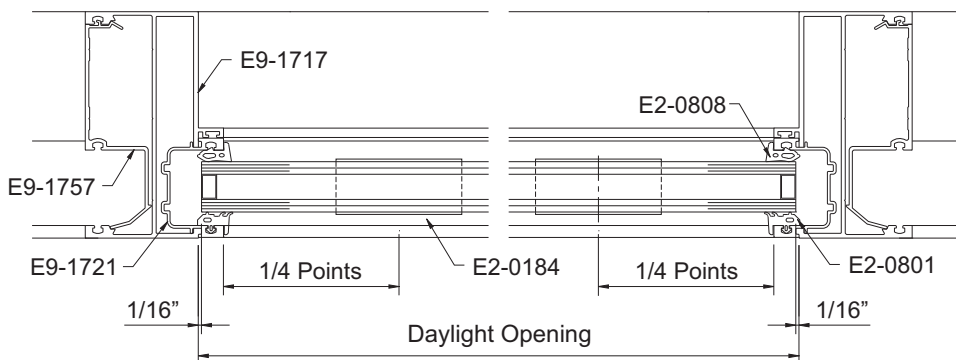

 **YKK AP America Inc.**

270 Riverside Parkway

Suite 100

Austell, Georgia 30168

www.ykkap.com