

YSK 750 Mid-rise Sloped Glazing System

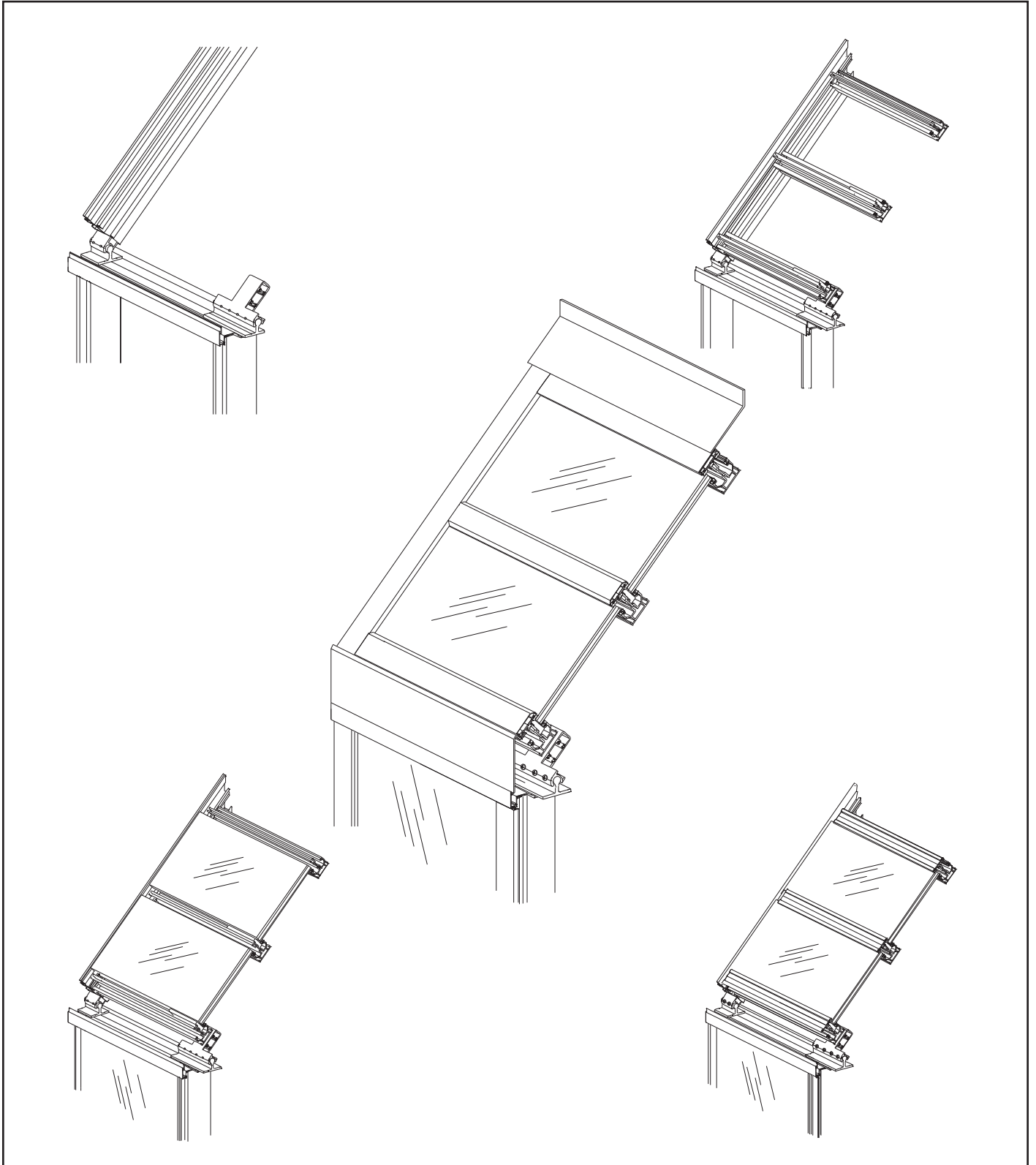

Installation Manual

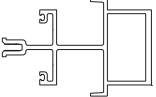
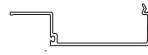
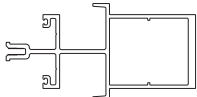

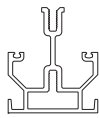





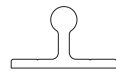

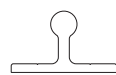

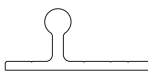

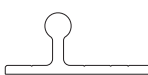

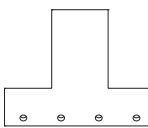

TABLE OF CONTENTS

Installation Notes	Page ii
PARTS DESCRIPTION	
Framing Members/Accessories	Pages 1 & 2
Accessories	Pages 2 & 3
FRAME FABRICATION	
Fabricate Jamb/Vertical Mullions for Anchor Supports	Page 4
Fabricate Gutter Members.....	Pages 5 to 7
Fabricate Rafter Members.....	Pages 8 to 14
Fabricate Purlin Members	Page 15
Fabricate Adaptors, Pocket Fillers & Rafter Pressure Plate	Page 16
Fabricate Purlin Pressure Plates & Face Covers.....	Page 17
Fabricate Gutter Transition Closure	Page 18
Fabricate End Plate Closure	Page 19
FRAME INSTALLATION	
Install End Plate Closure	Page 20
Install Framing Members	Pages 21 & 22
Install Anchor Hinge and Weep Baffle	Page 23
Install Pocket Fillers and Interior Gaskets.....	Page 24
Gasket Usage Table.....	Page 25
Seal Gasket Intersections.....	Page 26
Install Gutter Transition Closure and Setting Blocks.....	Page 27
GLAZING	
Install Side Blocks	Page 28
Install Glazing Adaptors.....	Pages 28 & 29
Install Glass and Rafter Pressure Plates	Page 30
Install Purlin Pressure Plates	Page 31
Structural Silicone Glazed Purlins	Pages 31 & 32
Apply Pressure Plate Sealant.....	Page 33
Apply Exterior Weather Seal for SSG Purlins	Page 34
Install Rafter Covers	Page 35
Install Purlin Covers.....	Page 36
Install Interior Glass Stops	Page 37
Apply Perimeter Sealant.....	Page 38
Example Rafter Calculations	Pages 39 & 40



Installation Notes

1. Do not drop, roll or drag boxes of aluminum framing. Move and stack boxes with proper support to prevent distortion. If fork lifts are used be especially careful about striking the boxes when lifting or moving.
2. Store in a dry, out of the way area. If rain exposure, condensation or any water contact is likely, then all packaging material should be removed. Wet packaging materials will discolor aluminum finishes and paints.
3. All materials should be checked for quality upon receipt. Check to make sure that you have the required shims, sealants, supplies and tools necessary for the installation.
4. Carefully check the openings and surrounding conditions that will receive your material. Remember, if the construction is not per the construction documents, it is your responsibility to notify the general contractor in writing. Any discrepancies must be brought to the general contractor's attention before you proceed with the installation.
5. Gather your shop drawings, materials, packing list, and this installation manual. Carefully review parts location, the sequence it goes therein, when you glaze it and how you seal it. Installation instructions are of a general nature and may not cover every condition you will encounter. The shop drawings and/or installation manuals were prepared specifically for the product.
6. Any material substitutions must be of equal or greater quality.
7. Make certain that material samples have been sent for compatibility testing for all manufacturer's sealants involved. Make certain sealants have been installed in strict accordance with the manufacturer's recommendations and specifications.
8. Remember to isolate in an approved manner all aluminum from uncured masonry or other incompatible materials.
9. System-to-structure fasteners are not supplied by YKK AP. Fasteners called out on shop drawings are to indicate minimum sizes for design loading.
10. If any questions arise concerning YKK AP products or their installation, contact YKK AP technical center for clarification before proceeding.
11. YKK AP store front and/or curtain wall framing is typically completed before drywall, flooring and other products which may still be in process. Take the extra time to wrap and protect the work produced.
12. Check our website, www.ykkap.com, for the latest installation manual update prior to commencing work.

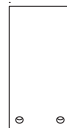
FRAMING MEMBERS / ACCESSORIES

	Rafter 2-1/2" x 5-3/8"	E9-5001		Glass Stop For E9-5009	E9-5010
	Rafter 2-1/2" x 7-3/8"	E9-5011		Gutter	E9-5019
	Purlin	E9-5002		Glass Stop For E9-5019	E9-5020
	SSG Purlin	E9-5003		Glazing Adaptor For 1/4" glazing	E9-5012
	Pressure Plate E9-5004 with E2-0103 isolator, punched 9" O.C. For 5/16", 1", 1-1/16" & 1-1/8" glazing	AS-5004		SSG Glazing Adaptor For 1/4" glazing	E9-5013
	Pressure Plate E9-5004 with E2-0403 isolator, punched 9" O.C. For 1-3/16", 1-1/4" & 1-5/16" glazing	AS-5004S		Anchor Plate For Rafter E9-5001 4-3/4" long	E1-1401
	Rafter / Top Purlin Face Cover	E9-5005		End Anchor Plate For Rafter E9-5001 4-3/4" long	E1-1402
	Intermediate Purlin Face Cover	E9-5006		Anchor Plate For Rafter E9-5011 6" long	E1-1403
	Bottom Purlin Face Cover	E9-5007		End Anchor Plate For Rafter E9-5011 6" long	E1-1404
	Pocket Filler For Rafter / Purlin	E9-5008		Intermediate Rafter Anchor Hinge For Rafters E9-5001 & E9-5011	E1-1405
	Gutter Use with E9-5001	E9-5009		Jamb Rafter Anchor Hinge For Rafters E9-5001 & E9-5011	E1-1406

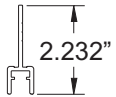
ACCESSORIES

 <p>Anchor Support For 3-3/4" deep mullions 2-3/4" long</p>	E1-1407	 <p>Side Block Adhesive backed</p>	E2-0407
 <p>End Anchor Support For 3-3/4" deep mullions 2-3/4" long</p>	E1-1408	 <p>Setting Block For SSG Purlin Adhesive backed</p>	E2-0408
 <p>Anchor Support For 5-1/4" deep mullions 4" long</p>	E1-1409	 <p>Wedge Gasket</p>	E2-0413
 <p>End Anchor Support For 5-1/4" deep mullions 4" long</p>	E1-1410	 <p>Interior SSG Glazing Spacer For Purlin</p>	E2-0414
 <p>Setting Block Base For SSG Purlin 5/16" to 1-1/8" glazing 5-1/4" long</p>	E1-1411	 <p>Interior SSG Glazing Spacer For Purlin</p>	E2-0415
 <p>Setting Block Base For SSG Purlin 1-3/16" to 1-5/16" glazing 5-1/4" long</p>	E1-1412	 <p>Sealant Tape 1/8" Face Clearance</p>	E2-0416
 <p>Anchor for Head Angle 2" x 2" x 1/4" 4-1/2" long</p>	E1-1413	 <p>Exterior Glazing Gasket 1/4" Face Clearance</p>	E2-0120
 <p>Exterior Glazing Spacer</p>	E2-0400	 <p>Weep Baffle For Gutter</p>	E2-0099
 <p>Interior Glazing Gasket 5/16" Face Clearance</p>	E2-0401	 <p>Weather Gasket For Anchor Plate E1-1401 6" x 3"</p>	E2-0409
 <p>Interior Glazing Gasket 3/16" Face Clearance</p>	E2-0402	 <p>Weather Gasket For Anchor Plate E1-1402 4-3/4" x 3"</p>	E2-0410
 <p>Setting Block For Purlin Adhesive backed</p>	E2-0405	 <p>Weather Gasket For Anchor Plate E1-1403 6" x 4-1/4"</p>	E2-0411

ACCESSORIES

	<p>Weather Gasket For Anchor Plate E1-1404 4-3/4" x 4-1/4"</p>	<p>E2-0412</p>		<p>1/4"-20 x 5/8" HWHTCS Type F Steel Zinc Plated</p>	<p>HF-2510</p>
	<p>3/8" Spring Lock Washer Stainless Steel</p>	<p>WS-3800 -SS</p>		<p>1/4 -20 x 1" HWHMS Steel Zinc Plated</p>	<p>HM-2516</p>
	<p>3/8"-16 Hex Nut Stainless Steel</p>	<p>HM-3800 -SS</p>		<p>1/4"-20 x 5/8" PHMSS Steel Zinc Plated</p>	<p>PM-2510</p>
	<p>3/8" Flat Washer Stainless Steel</p>	<p>WW-3800 -SS</p>		<p>#14 x 1-1/2" PHSMS Type AB Stainless Steel</p>	<p>PC-1424</p>
	<p>Splice Sleeve For Gutter (E9-5009)</p>	<p>E1-1414</p>		<p>#14 x 1" PHSMS Type AB Stainless Steel</p>	<p>PC-1416</p>
	<p>Splice Sleeve For Gutter (E9-5019)</p>	<p>E1-1415</p>		<p>#10 x 1/2" PHSMS Type AB Stainless Steel</p>	<p>PC-1008</p>
	<p>Splice Sleeve For Purlin Cover E9-5007</p>	<p>E1-1416</p>		<p>#10 x 1/2" FHSMS Type AB Stainless Steel</p>	<p>FC-1008</p>
	<p>3/8"-16 x 3-1/2" Hex. Head Bolt Stainless Steel</p>	<p>HM-3856 -SS</p>			
	<p>3/8"-16 x 1-1/4" Hex. Head Bolt Stainless Steel</p>	<p>HM-3820 -SS</p>			
	<p>1/4"-20 x 2-1/2" Hex. Head Bolt Steel Zinc Plated</p>	<p>HM-2540</p>			

FRAME FABRICATION

Your YSK 750 Sloped Glazed Wall may sit either on a masonry curb or a YCW 750 mid rise curtain wall. These instructions will assume that this slope glazed system will be constructed on a YCW 750 wall which abuts a vertical wall at each end.

YSK 750 sloped glazed system accommodates slope angles from a minimum of 15 degrees to a maximum of 60 degrees.

STEP 1 FABRICATE INTERMEDIATE AND JAMB MULLIONS FOR ANCHOR SUPPORTS

- Locate hole locations in each side of the top end of the mullions.
 - Drill 0.213" diameter (#3 drill bit) holes for 1/4"-20 screws in mullions and jamb for attachment of rafter anchor support.
- See **Detail 1**.

Dim "A"	Dim "B"
5-1/4"	2-3/4"
3-3/4"	1-1/2"

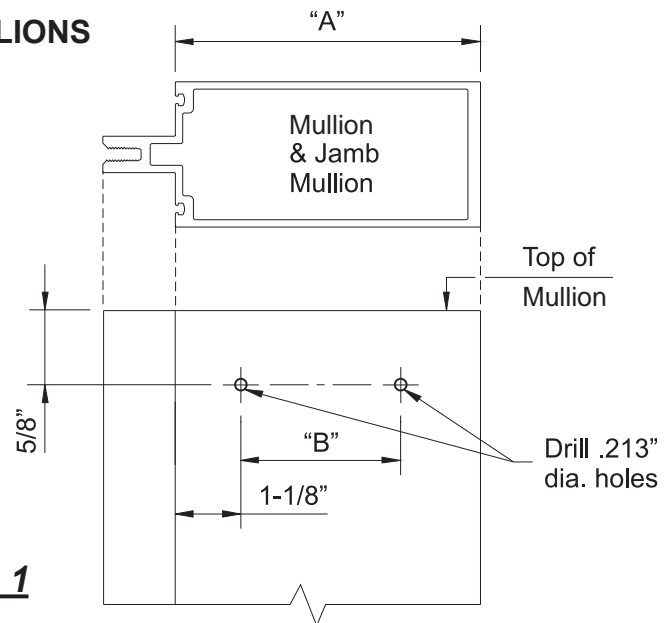

Detail 1

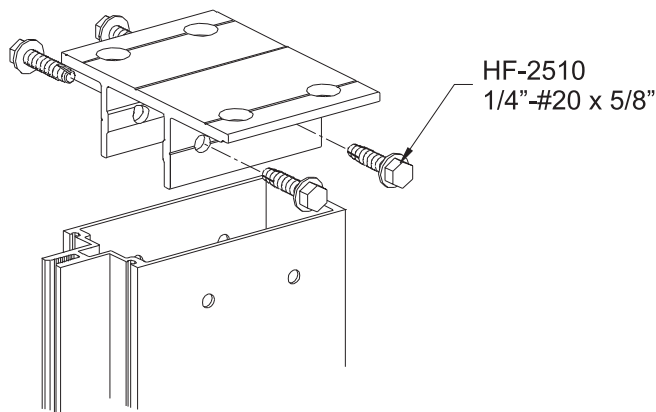

Detail 2

STEP 2 ATTACH ANCHOR SUPPORTS

- Install anchor supports into the top of each mullion of the YCW curtain wall with (4) HF-2510 fasteners.
- See **Detail 2**.

Dim "A"	For Int. Mullions	For Jamb
5-1/4"	E1-1409	E1-1410
3-3/4"	E1-1407	E1-1408

NOTE: For complete fabrication and installation instructions for the straight (base) wall, see instructions for that particular product.

FRAME FABRICATION

**STEP 3
FABRICATE GUTTER MEMBERS**

- Cut gutter member to the frame width of straight wall below.
- Mark the center line of the jamb and intermediate rafter members on the gutter member.
- Drill four 13/32" diameter holes in the gutter member using the anchor plate as a guide.

Caution: The end anchor plates are shorter than the anchor plates for the intermediate rafters.

- Mark the quarter points of each daylight opening in the bottom chamber of the gutter and drill a 3/8" diameter weep hole at each location marked.
- De-burr the holes and remove filings that would inhibit the flow of water out of the gutter.

See **Detail 3**.

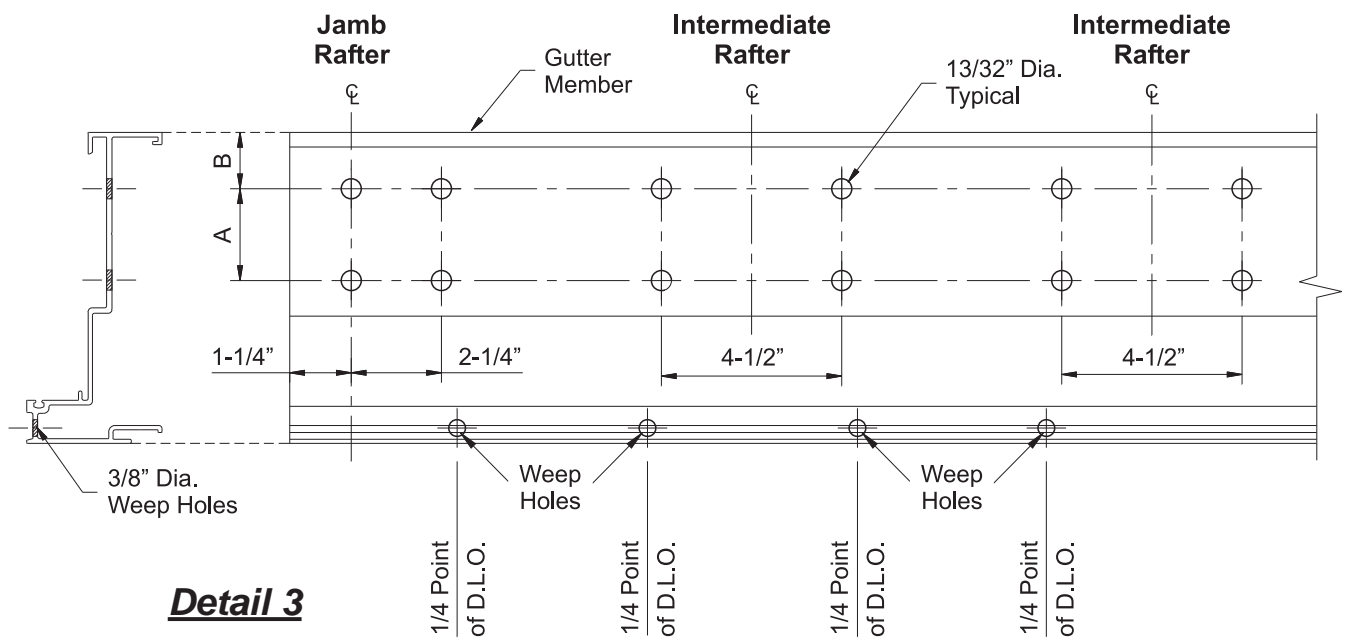

Detail 3

Gutter	Dim "A"	Dim "B"
E9-5009	1-1/2"	1-5/16"
E9-5019	2-3/4"	1-9/16"

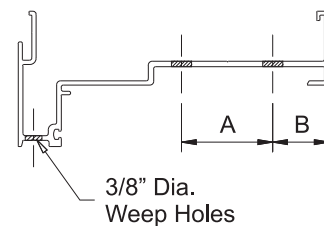

FRAME FABRICATION

**STEP 4
ASSEMBLE GUTTER MEMBERS**

- Lay gutter member on top of anchor supports at the top of each vertical mullion.
- Over each set of four holes place the appropriate weather gasket and anchor plate.
- Bolt each assembly together using four 3/8"-16 x 1-1/4" bolts (HM-3820-SS) along with nuts and washers as shown. Tighten the nuts until they are finger tight.

See **Detail 4**.

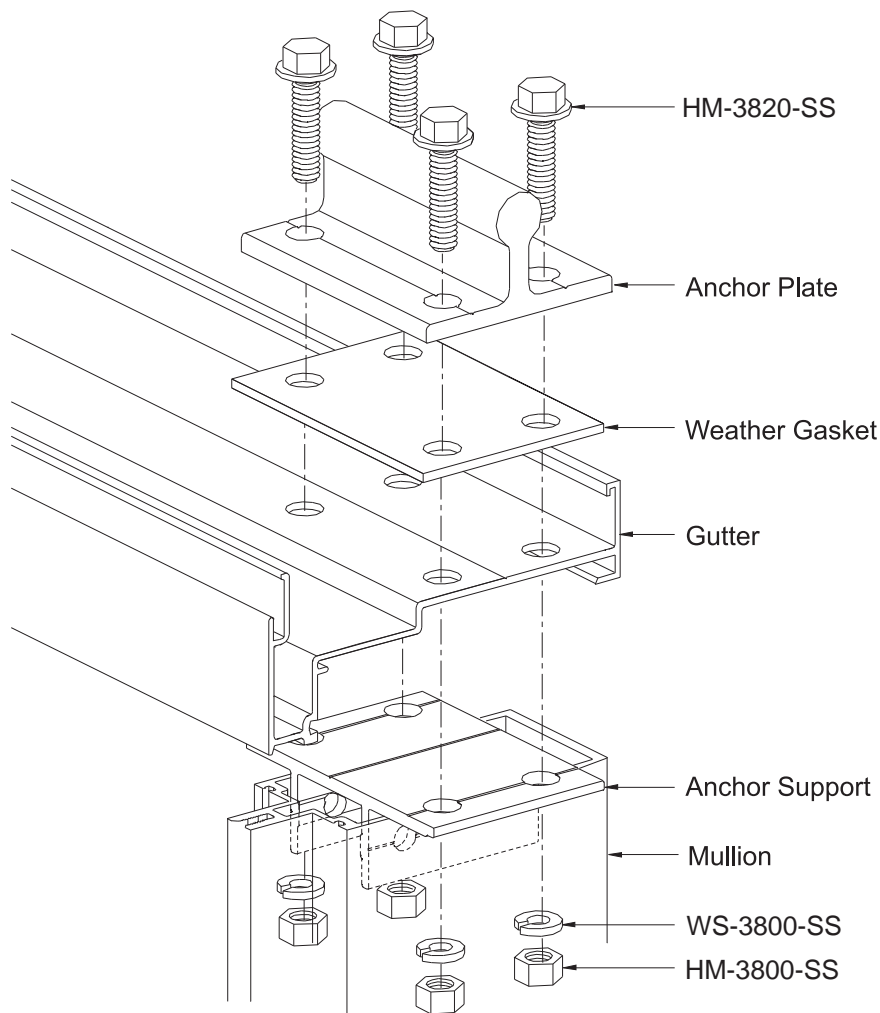

Detail 4

FRAME FABRICATION

STEP 4 ASSEMBLE GUTTER MEMBERS (Continued)

If the opening requires that the gutter be spliced:

- Locate splice in the center of a bay.
- Allow for a 3/8" joint between gutter members.

Gutter Member	Splice Sleeve
E9-5009	E1-1414
E9-5019	E1-1415

Attach Splice Sleeve:

- Apply bond breaker tape to the center of the splice sleeve from front to back on the underside.
- The splice sleeve must be slid eight to ten inches into one of the ends of the gutter members that are to be spliced.
- Once the gutters have been anchored into place, spread a bed of sealant that completely covers the last 2-1/2" of the ends of the gutters that are to be spliced.
- Slide the splice sleeve into place so that it is centered on the splice.
- Attach one end of the splice sleeve to the gutter using one PC-1008 fastener.
- Seal the screw heads.
- Tool the sealant up and over the ends of the splice sleeve.

See **Detail 5**.

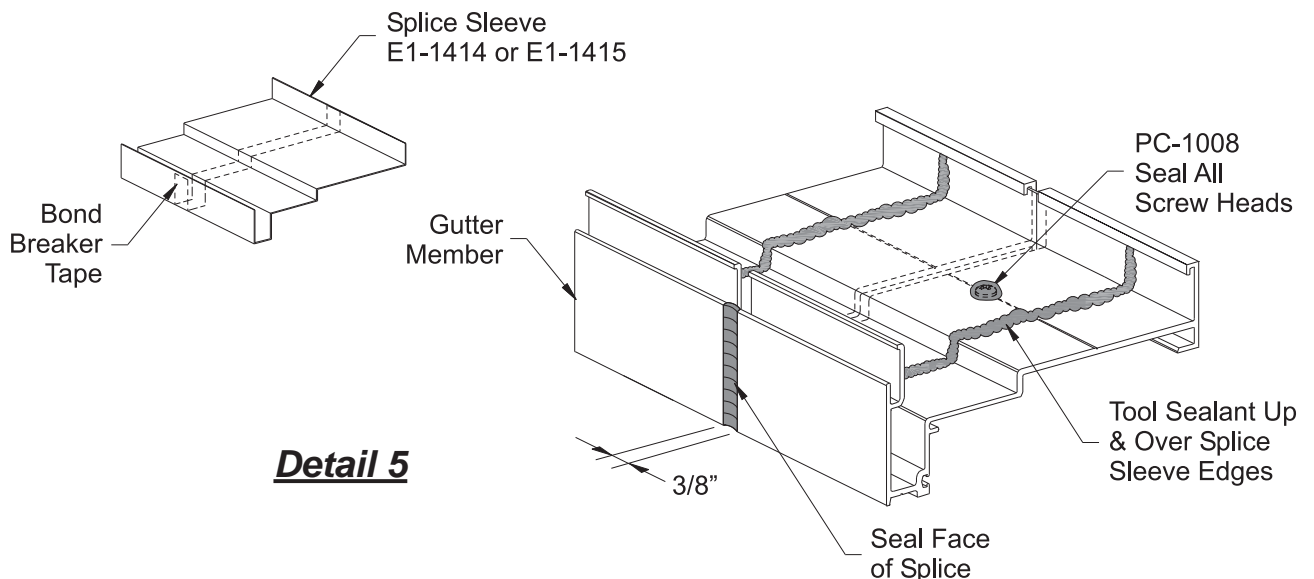

CAUTION: ATTACH ONLY ONE END OF THE SPLICE SLEEVE.

FRAME FABRICATION

CALCULATE RAFTER LENGTH

To determine rafter lengths follow the calculations in **Steps 5**.

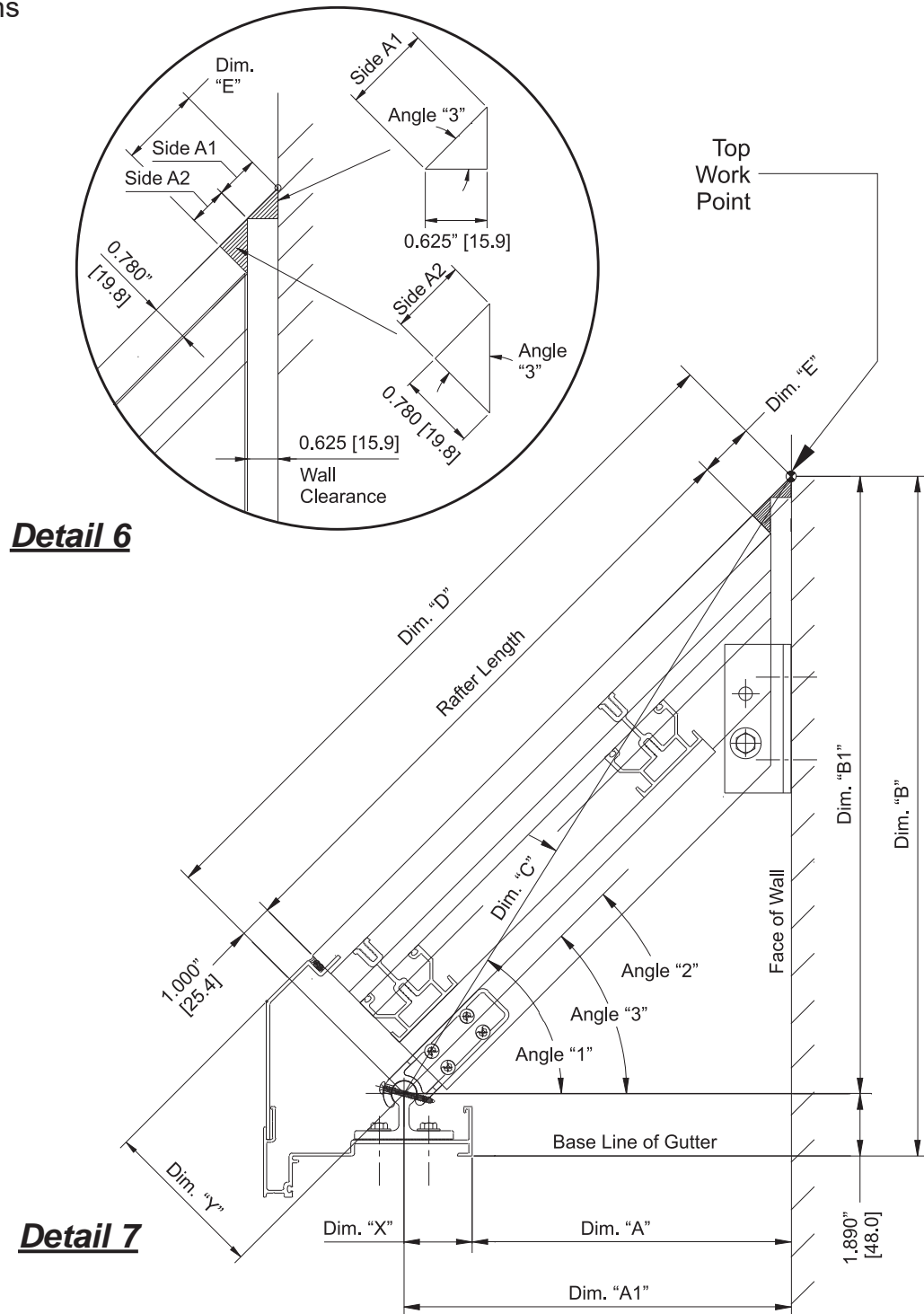

See Example Calculations Pages 9 & 40.

FRAME FABRICATION

**STEP 5
CALCULATE RAFTER LENGTH**

Determine dimension “A” from the wall to the inside face of gutter. Mark a work point on the vertical wall, where the top surface of the rafter cover will intersect the wall. Measure from this “Top Work Point” to the base line of the gutter. This will be dimension “B”. See **Detail 7**.

Calculate Dimension “A1”

Dim. “A1” = Dim. “A” + Dim. “X” See below.

GUTTER	Dim.”X”
E9-5009	2.063”
E9-5019	2.312”

Calculate Dimension “B1”

Dim. “B1” = Dim. “B” – 1.890”

Calculate Dimension “C”

Dim. “C” = $\sqrt{\text{Dim. “A1”}^2 + \text{Dim. “B1”}^2}$

Calculate Angle “1”
 Angle “1” = $\tan \text{Angle} \frac{\text{Dim. “B1”}}{\text{Dim. “A1”}}$
 See **Detail 7**.

Calculate Dimension “D”

Dim. “D” = $\sqrt{\text{Dim. “C”}^2 - \text{Dim. “Y”}^2}$

Calculate Angle “2”
 Angle “2” = $\sin \text{Angle} \frac{\text{Dim. “Y”}}{\text{Dim. “C”}}$

RAFTER	DIM.”Y”
E9-5001	4.913”
E9-5011	6.308”

Calculate Angle “3”

Angle “3” = Angle “1” – Angle “2”
 See **Detail 6**.

Calculate side “A1” of imaginary triangle

Side “A1” = $\frac{0.625}{\cos \text{Angle “3”}}$

See **Detail 7**.

Calculate side “A2” of imaginary triangle

Side “A2” = 0.780 x tan Angle “3”

Calculate dimension “E”

Dim. “E” = Side “A1” + Side “A2”

Calculate Rafter Length

Rafter Length = Dim.”D” – Dim.”E” – 1.000”

CAUTION: Fabricate one test rafter first.

FRAME FABRICATION

**STEP 6
FABRICATE TEST RAFTER**

-Cut and miter one rafter using angle "3" and the rafter length, calculated in Step 5.
See **Detail 8**.

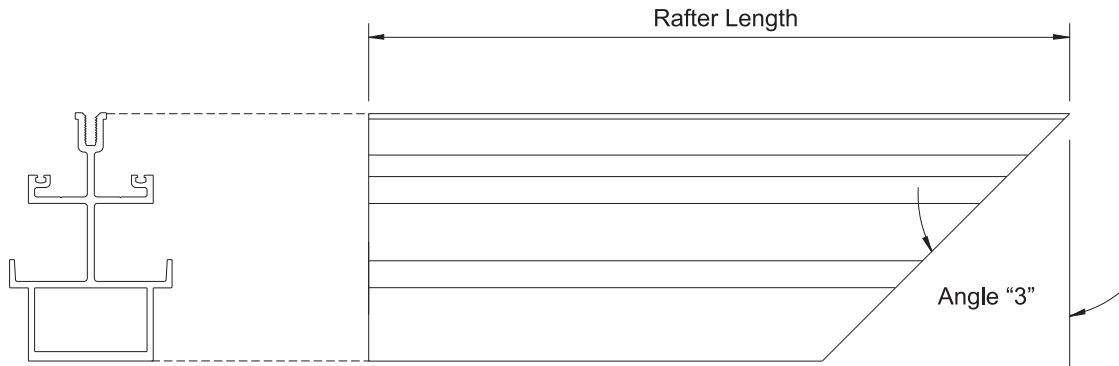

Detail 8

THIS IS A TEST RAFTER.

-Layout four hole locations on each side of the bottom of the rafter as shown in **Detail 9**.
-Drill 0.281" diameter (#9/32 drill bit) holes at each location marked.
-Attach a E1-1406 anchor hinge using eight #14 x 1" PHSMS/AB (PC-1416) fasteners.

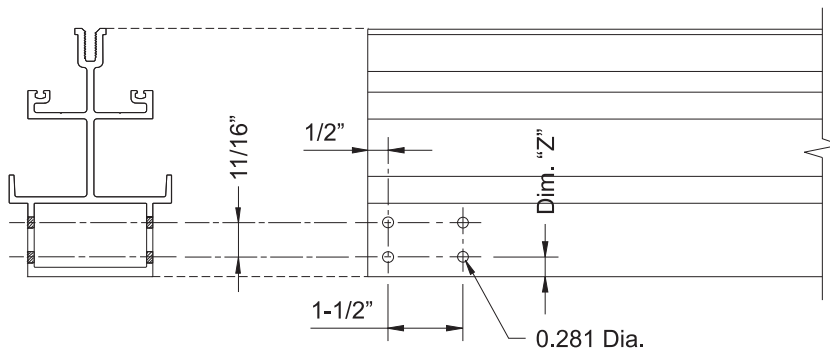

Detail 9

Rafter	Dim. "Z"
E9-5001	7/16"
E9-5011	1/2"

FRAME FABRICATION

STEP 7 CHECK TEST RAFTER

The assembly just completed was a test rafter. Hold the anchor hinge in line with, and to one side of an anchor plate. Slide the hinge onto the plate and let the top of the rafter rest against the vertical wall.

Place a spacer of any material, 5/8" in thickness, between the top end of rafter and the vertical wall.

See **Detail 10**.

TEST:

- (A) Sight along the top surface of the rafter to a spot on the vertical wall. This point should appear to be approximately 3/4" below the work point.
- (B) View the mitered end of the rafter, by sighting parallel along the wall. This cut edge should be parallel to the vertical wall.
- (C) If either test "A" or "B" are not accurate go back to **Step 5** and make appropriate corrections
- (D) Repeat the above procedure at several points along the wall.

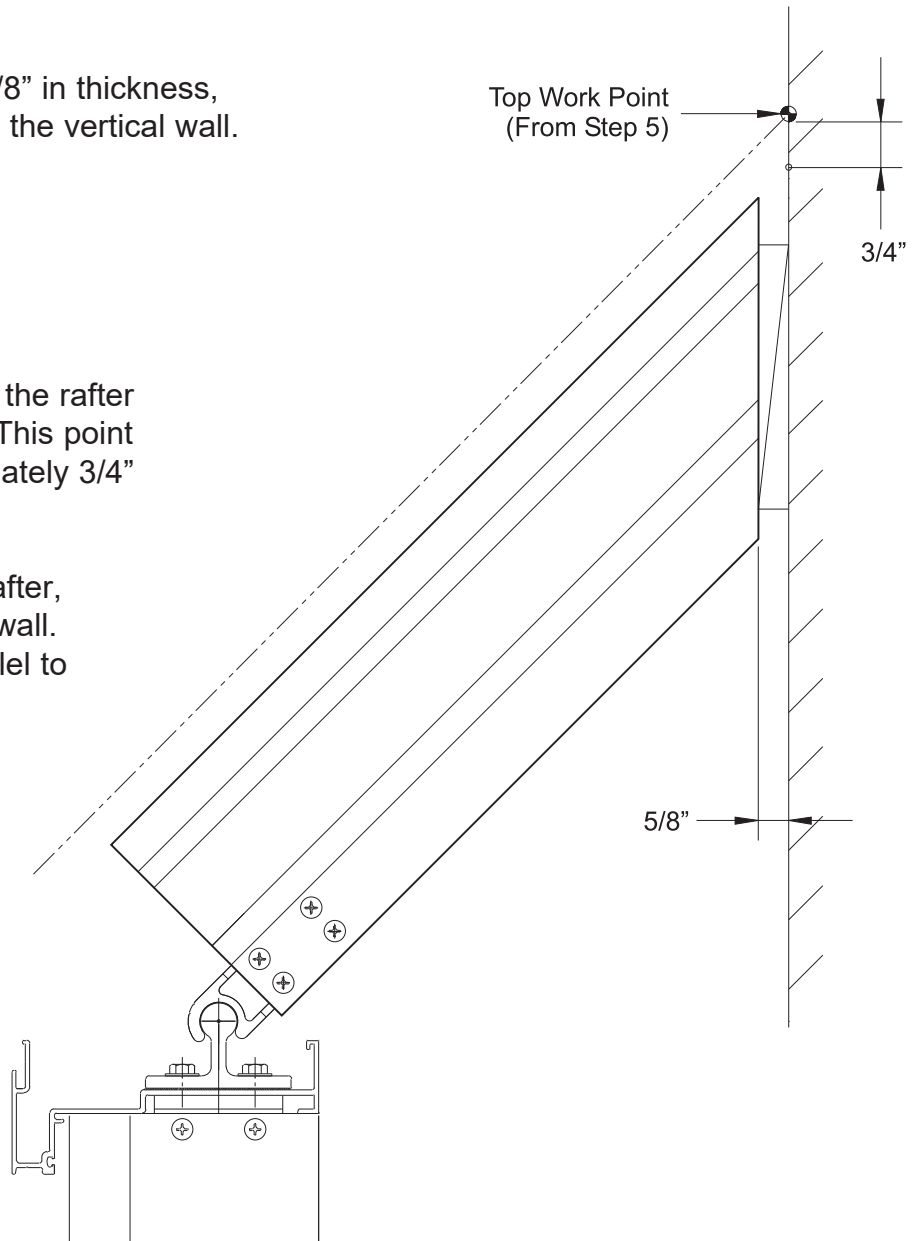

Detail 10

FRAME FABRICATION

STEP 8 FABRICATE RAFTERS

- Having determined the correct rafter length and miter angle, proceed to cut and miter all rafters.
- Remove a portion of the gutter lip:
 - Draw a parallel line 2" away from the mitered edge.
 - Cut the gutter lip to a depth of 3/8" at the point that intersects the parallel line.
 - Do this on both sides of the rafter.
- Drill a 7/16" diameter hole through both sides of all rafters as shown.

See **Detail 11**.

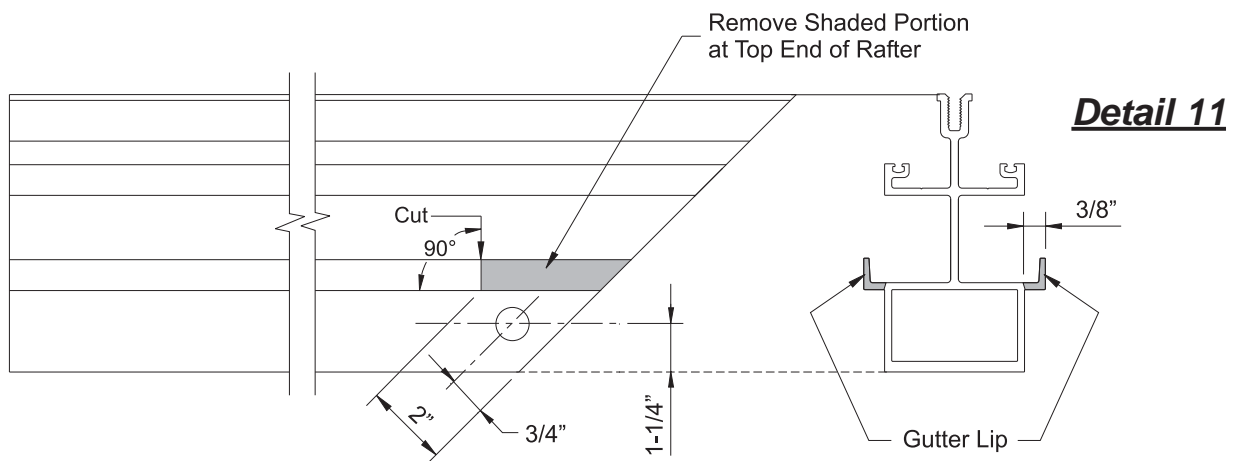

Jamb Rafters:

- Remove 1-1/2" of gutter lip at the bottom of two of the rafters previously fabricated.
- Only remove the lip on one side of the first rafter and from the opposite side of the second rafter. These are the jamb rafters.

See **Detail 12**.

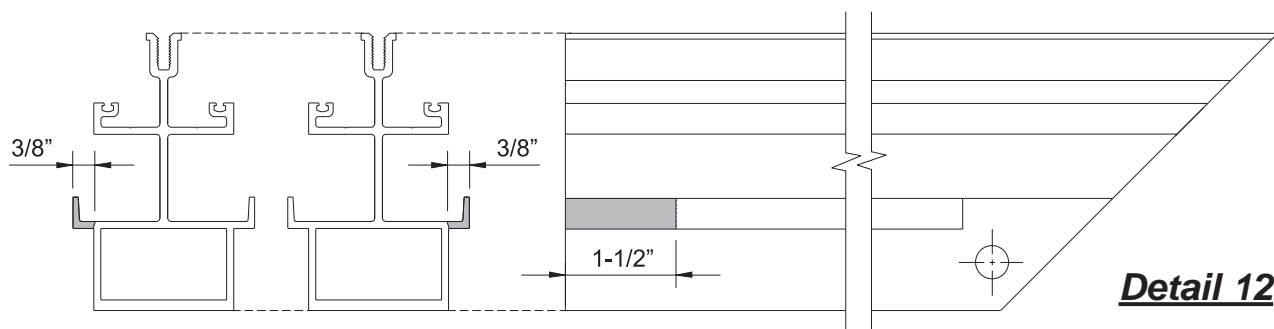

FRAME FABRICATION

STEP 8 (Continued) FABRICATE RAFTERS

- Layout four hole locations on each side of the bottom of the rafter as shown in **Step 6**.
- Drill 0.281" diameter (#9/32 drill bit) holes at each location marked.

Install the appropriate anchor hinges in each rafter:

- Attach jamb rafter anchor hinges, E1-1406, with (6) PC-1416 fasteners.
(Omit the two lower outside fasteners at jamb rafters)
- Attach the mid rafter anchor hinges, E1-1405, with (8) PC-1416 fasteners.

See **Detail 13**.

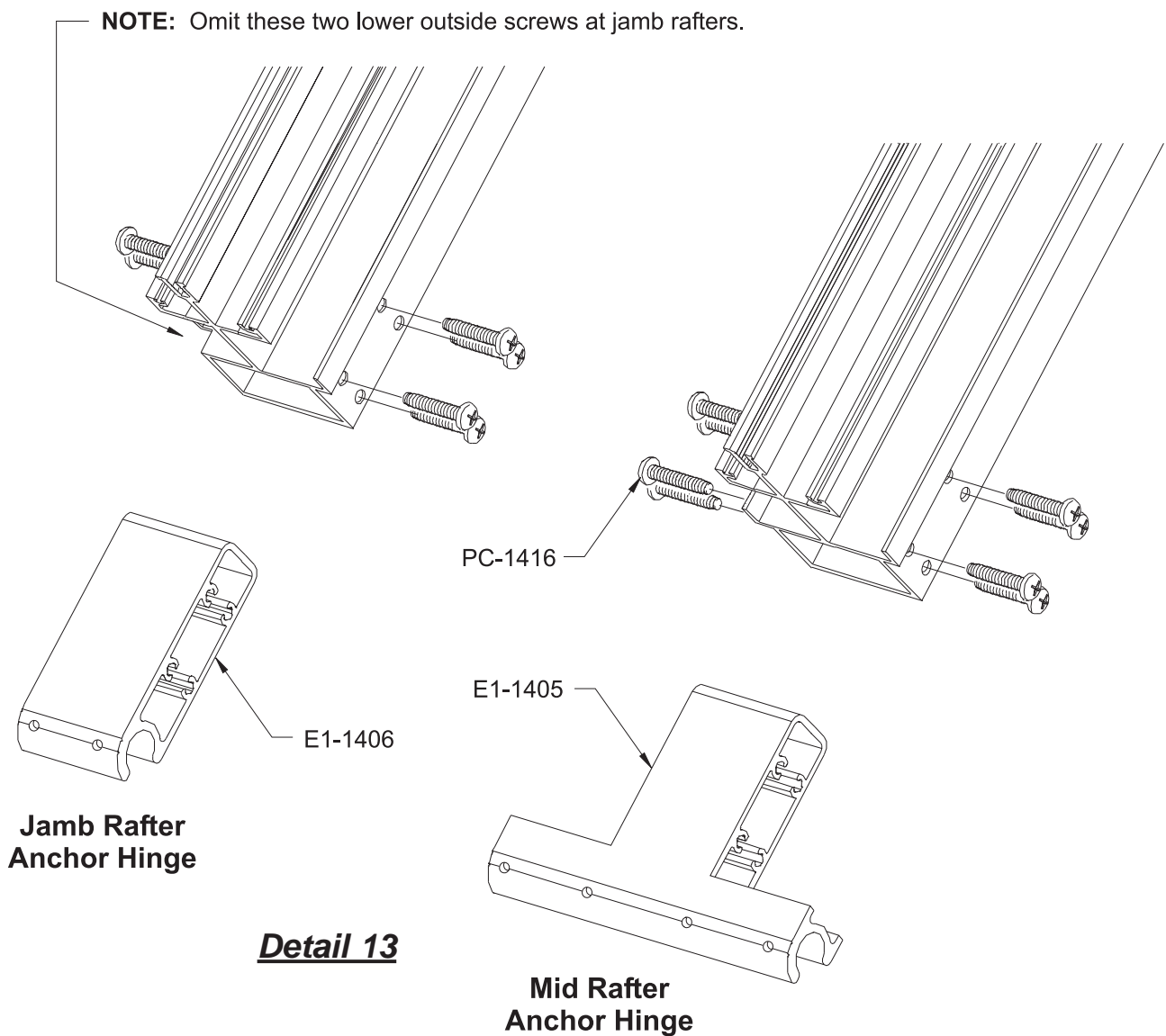

FRAME FABRICATION

**STEP 8 (Continued)
FABRICATE RAFTERS**

-Measure the rafter gutter length (G.L.) and subtract(-) 2-1/2".

$G.L. - 2-1/2" =$ Distance between centerlines of top and bottom purlins.

Divide this dimension by the number of lites in each bay.

This is Dimension "L" in **Detail 14**.

If purlins are not equally spaced, lay them out according to the shop drawings.

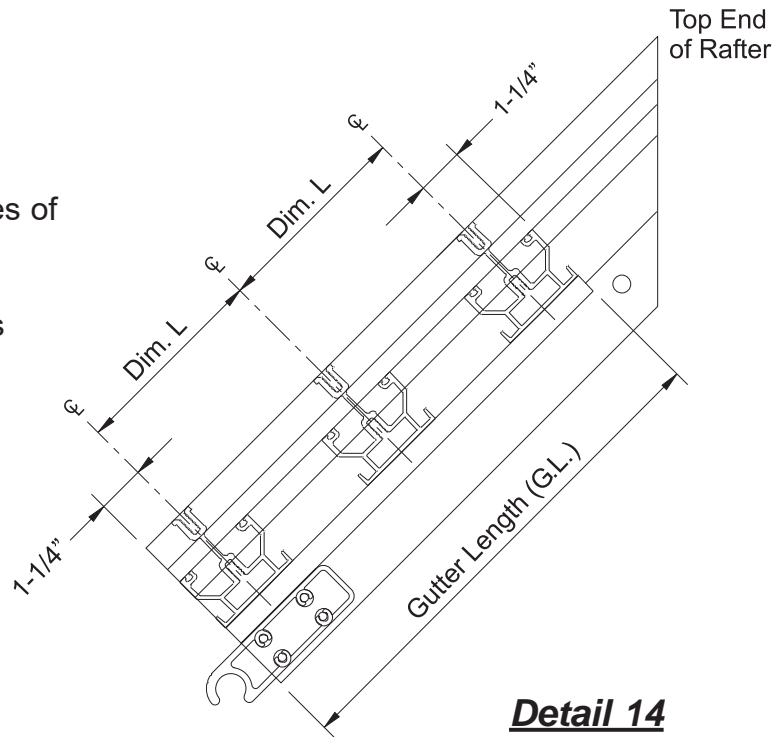

Detail 14

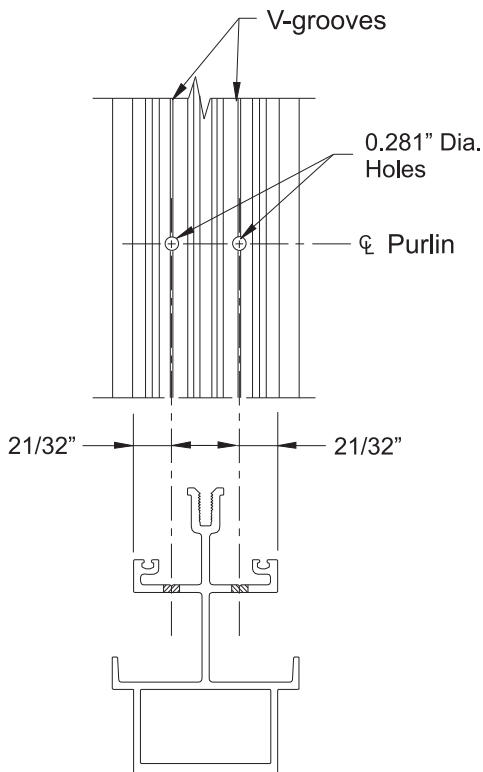

Detail 15

-Measure up 1-1/4" from the bottom of the rafter.

-Mark the centerline of the bottom purlin along the "V"-groove.

-Continue laying out purlin centerlines on the rafter, using Dimension "L" calculated above.

-Drill two 0.281" diameter (#9/32 drill bit) holes at each purlin centerline.

See **Detail 15**.

NOTE: Drill holes at glass side only on jamb rafters.

FRAME FABRICATION

STEP 9
FABRICATE PURLINS

-Using the centerline to centerline dimension between rafters, subtract 3/8" to obtain the overall length of each purlin in that run.
See **Detail 16**.

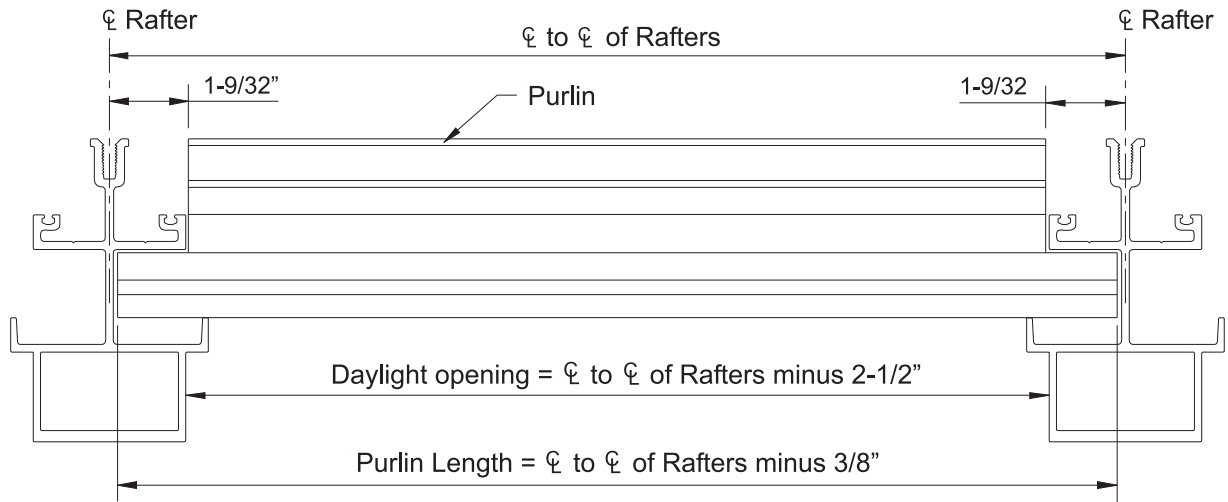

Detail 16

-Notch each end of the purlins as shown below to create a lap joint at the rafters.

See **Detail 17**.

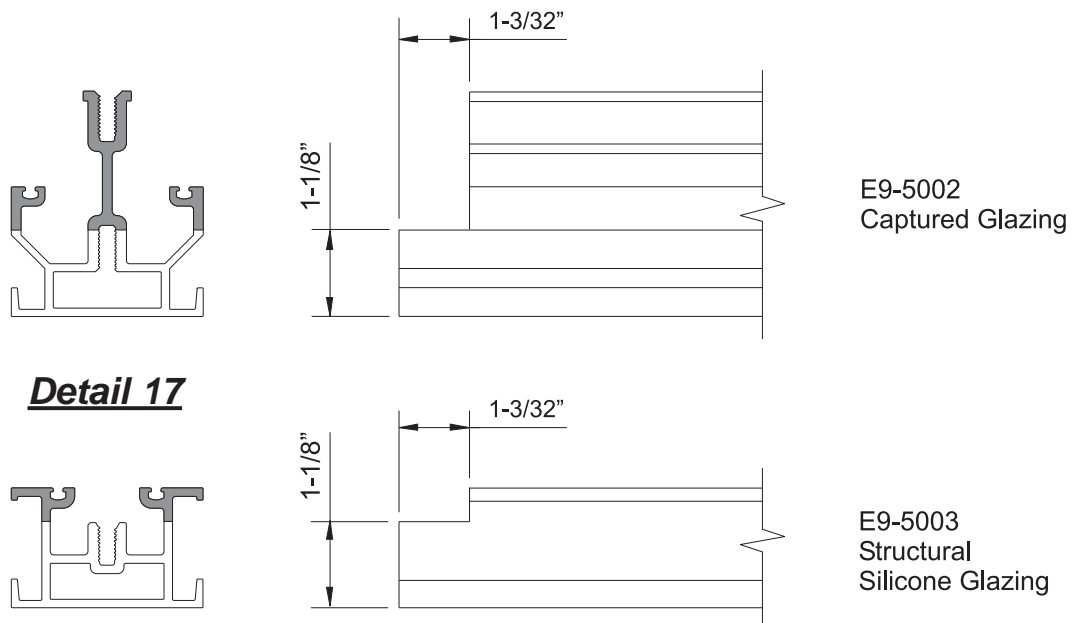

Detail 17

FRAME FABRICATION

STEP 10 FABRICATE ADAPTORS FOR 5/16" GLAZING

For both captured glazing and structural silicone glazing, the same adaptor is used in the rafter. For all rafters receiving 5/16" infills, cut a piece of 5/16" glazing adaptor, E9-5012, to the Gutter Length (G.L.) dimension calculated in **Step 8** on **Page-14**.

Captured glazed purlins will require the same adaptor, E9-5012, under each lite.

- Cut these adaptors to the centerline to centerline dimension of rafters minus(-) 2-9/16".
- Structural silicone glazed purlins require adaptor, E9-5013.
- Cut these adaptors to the centerline to centerline dimension of rafters minus(-) 2-9/16".

STEP 11 FABRICATE GLAZING POCKET FILLERS

The top and bottom purlins in each bay require a filler, E9-5008, for pockets opposite the glazing.

- Cut these pocket fillers to the centerline to centerline dimension of rafters minus(-) 2-9/16".
- See **Detail 35** on **Page-24**.

The two jamb rafters also require pocket filler, E9-5008.

- Cut these two pieces the same length as the Gutter Length (G.L.) calculated in **Step 8**.
- See **Detail 34** on **Page-24**.

STEP 12 FABRICATE RAFTER PRESSURE PLATES

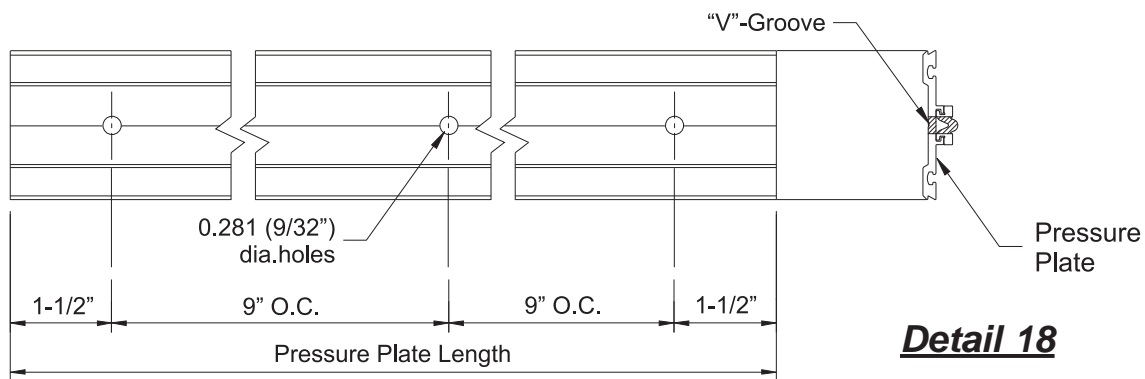

- Cut intermediate rafter pressure plate to the Rafter Length (R.L.) minus(-) 2-1/2".
 - Pressure plate stock lengths are punched with 0.281" diameter (9/32 drill bit) holes at 9" O.C. Additional holes may have to be drilled to ensure a hole within 1-1/2" of each end.
- Cut jamb rafter pressure plates to the G.L. dimension.
See **Detail 18**.

FRAME FABRICATION

STEP 12 (Continued) FABRICATE RAFTER PRESSURE PLATES

-Cut the top and intermediate purlin pressure plates to the daylight opening (D.L.O.) between rafters minus(-) 1/8".

-The bottom purlin pressure plate runs continuous between the jambs. Cut the bottom purlin pressure plate to the same length as the sill gutter member minus(-) 2-9/16" for each jamb member (allow 2-1/2" for the jamb and 1/16" for tolerances).

-Splice the bottom purlin pressure plate, when required, at the centerline of the rafter.

See **Detail 19**.

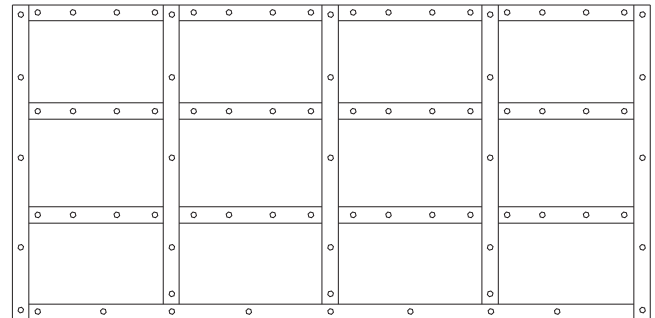

Detail 19

STEP 13 FABRICATE FACE COVERS

Rafter Covers:

-Cut intermediate rafter covers to the same length as the intermediate rafter pressure plates plus(+) 1/2".

-Miter cut one end at a 45 degree angle.

See **Detail 20**.

-Cut jamb rafter covers to the same length as the jamb rafter.

Purlin Covers:

-Cut the top and intermediate purlin covers the daylight opening between rafters minus(-) 1/16".

-Cut the bottom purlin cover to the same length as the bottom purlin pressure plate.

See **Detail 21**.

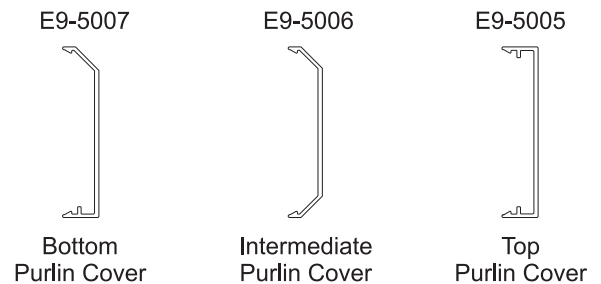

Bottom Purlin Cover

Intermediate Purlin Cover

Top Purlin Cover



Top of Cover

Detail 20

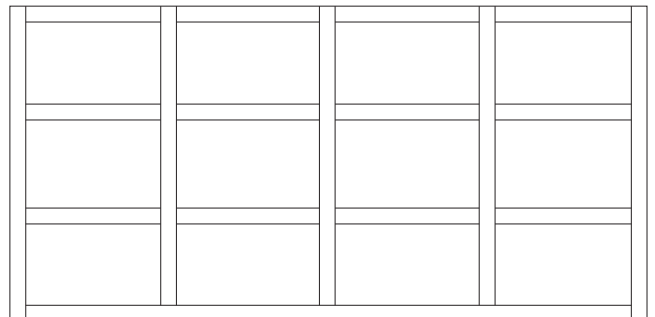

Detail 21

NOTE: Bottom purlin cover runs continuous between jamb rafter covers.

FRAME FABRICATION

**STEP 14
FABRICATE GUTTER TRANSITION CLOSURE**

-Notch transition closure at jambs as shown in **Detail 22**.

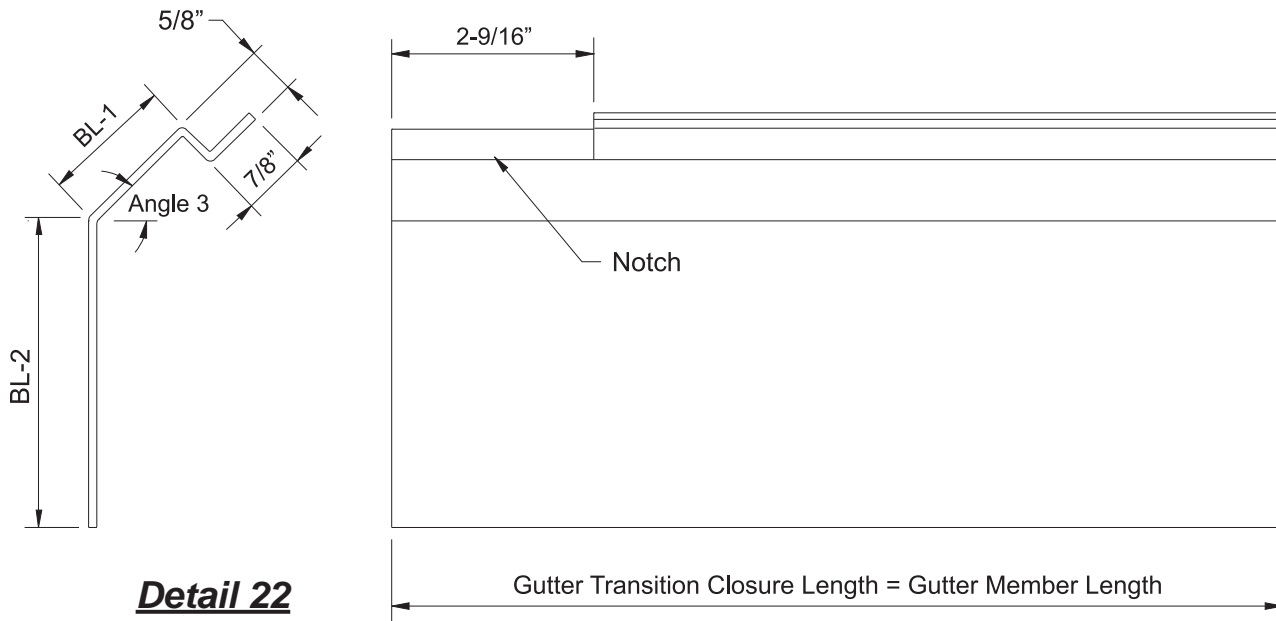

Detail 22

- Use angle 3 as calculated in **Step 5**.
- Determine the brake length dimensions, “BL-1” and “BL-2” from shop drawings.
- Cut 0.090-0.125” thick aluminum brake metal gutter transition closure to the same length as the gutter members.

- Splice transition closure at the mid-point between rafters.
 - Allow a 3/8” joint between the ends and splice with a piece of brake metal located on the inside faces.
 - Apply bond breaker tape over the brake metal sleeve.
 - Seal the splice with sealant.

See **Detail 23**.

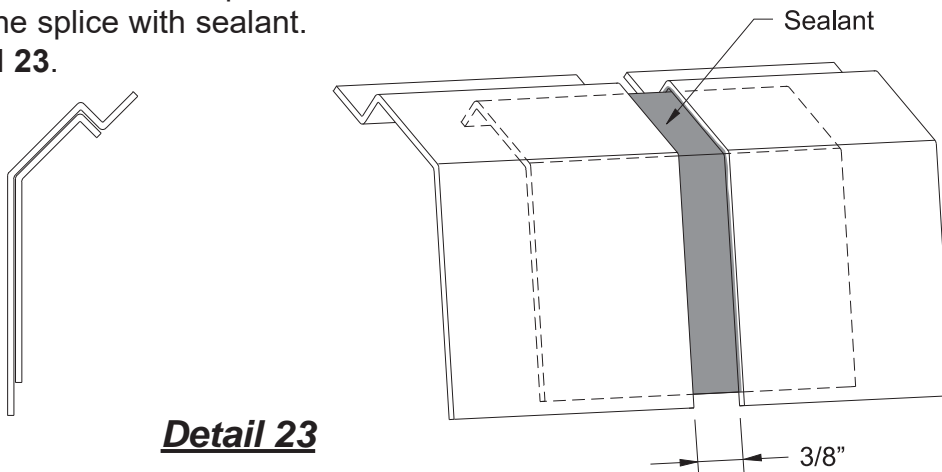

Detail 23

FRAME FABRICATION

STEP 15 FABRICATE END PLATE CLOSURE

- Fabricate end closure plates from 1/8" aluminum to match your combination of materials.
- Lay out a pattern starting at point "P".

GUTTER	RAFTER	FAB. DETAIL
E9-5009	E9-5001	A
E9-5019	E9-5011	B

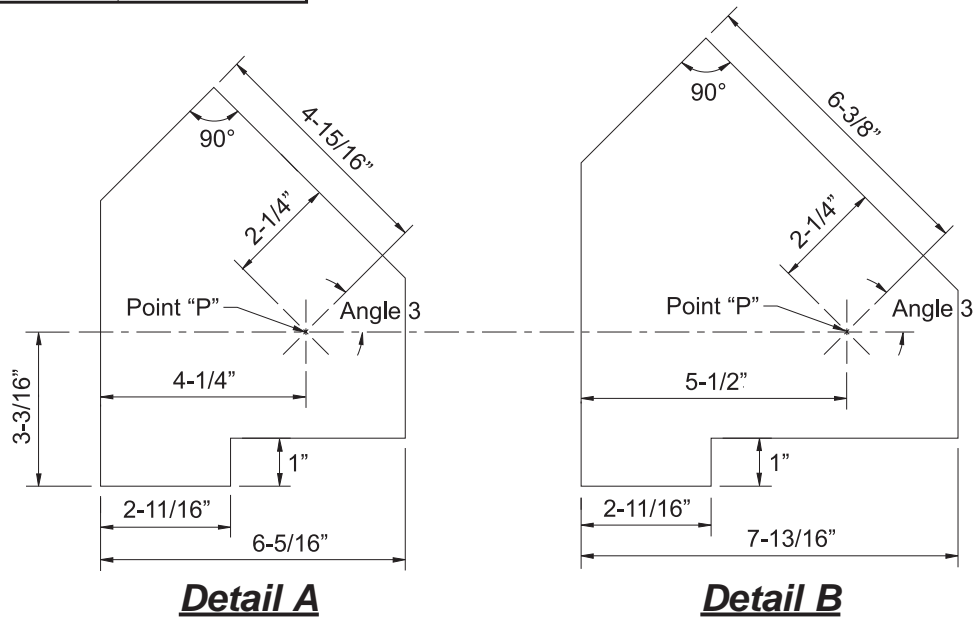

- Fabricate small angle clips to attach the end plate closure.
- Screw attach each angle to the end plate closure with PC-1008 fasteners.
- Seal the heads of all fasteners.

See **Detail 24**.

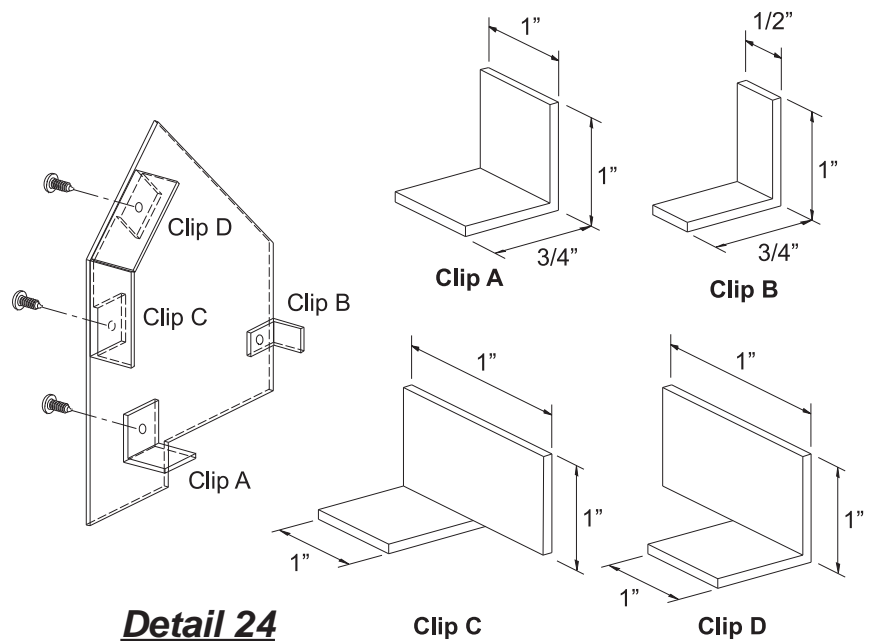

FRAME INSTALLATION

**STEP 16
INSTALL END PLATE CLOSURE**

-Position the end plate closure at the end of the gutter member as shown in Detail 25.

-Attach the end plate closure assembly to the gutter member using #10 pan head sheet metal fasteners.

See **Detail 25**.

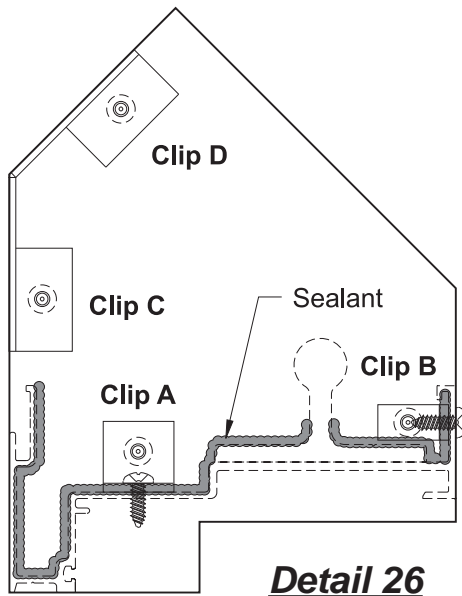
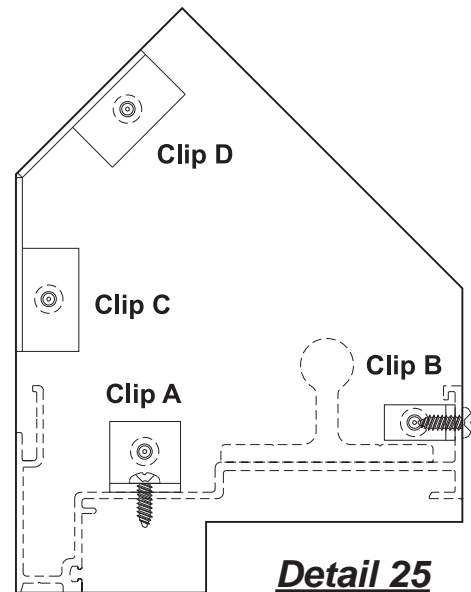

-Apply sealant to the joint between the gutter member and the end plate closure.

-Tool the sealant to ensure a water tight joint.

See **Detail 26**.

FRAME INSTALLATION

STEP 17 INSTALL JAMB RAFTER

- Take the left jamb rafter and slide the anchor hinge over the anchor plate and rest the top of the rafter against the vertical wall above.
 - Place a 5/8" spacer between the wall and the end of rafter.
- See **Detail 27**.

Note: Install framing members from left to right.

- Attach an anchor clip, E1-1413, on the inside of the jamb rafter.
 - Line up the bottom hole of the anchor clip with the hole in the jamb and mark the location for the second hole.
 - Remove the jamb rafter and drill a 7/16" dia. hole at the location just marked.
 - Attach the anchor clip to the jamb rafter using (2) HM-3856-SS HH bolts.
 - Reinstall the jamb rafter.
 - Anchor the jamb to the structure using the proper type and size of fasteners called for in the engineering calculations.
- See **Detail 28**.

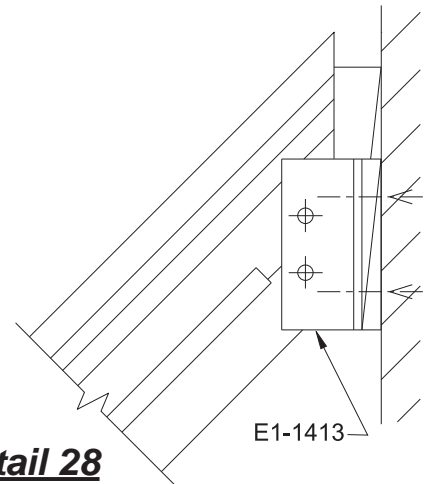
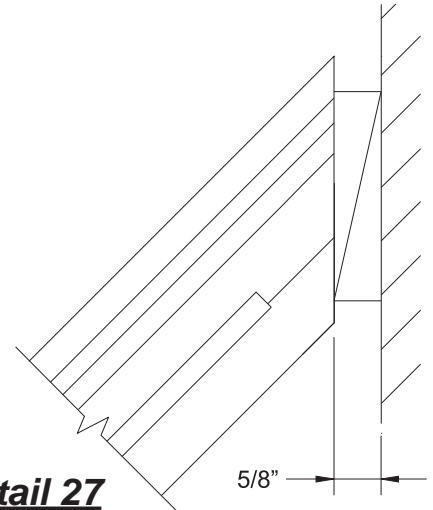

STEP 18 INSTALL PURLINS

- Just before installing purlins, apply sealant to all surfaces in the two planes shown in **Detail 29**.

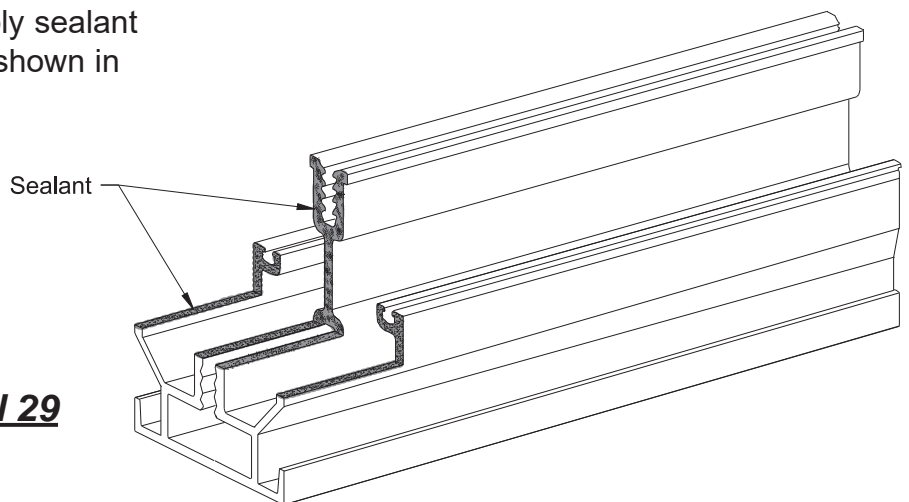

FRAME INSTALLATION

STEP 19 INSTALL INTERMEDIATE RAFTERS

- Slide the first intermediate rafter onto its anchor plate.
 - Guide all purlins in the first bay into place and tap the rafter into position.
 - Install two 1/4"-20 x 5/8" (PM-2510) screws at each rafter/purlin intersection.
- See **Detail 30**.

CAUTION: You must install all of the purlins in each bay before proceeding with the next rafter.

CAUTION: If you are using structural silicone glazed purlins that require glazing adaptors, the adaptors must be installed before the purlins are slid into place. See **Step 28** on **Page 29**.

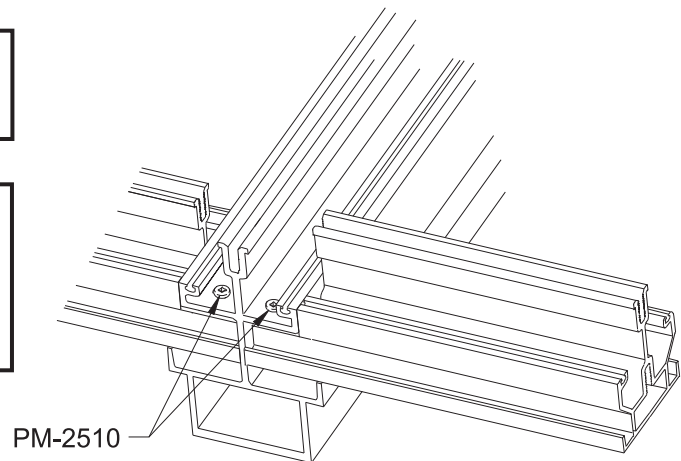

Detail 30

Install Top Anchors

The rafter top anchor, E1-1413, has 7/16" dia. holes properly spaced for the 3/8"-16 bolts that go through the rafter.

- Place a 3/8" x 3-1/2" bolt (HM-3856-SS) through the rafter with an anchor clip on each side. (Use the lower of the two 7/16" holes in one leg of the anchor)
 - Through the second 7/16" hole, mark where to drill the rafter so the second bolt can be inserted through both anchor clips. Drill a 7/16" dia. hole at this location.
 - Through each set of holes insert 3/8" x 3-1/2" bolt with a flat washer under the head and a lock washer under the nut.
 - Shim between the anchor clips and structure as necessary.
 - Fasten the anchor clip to the structure with proper size fasteners called in the engineering calculations.
- See **Detail 31**.

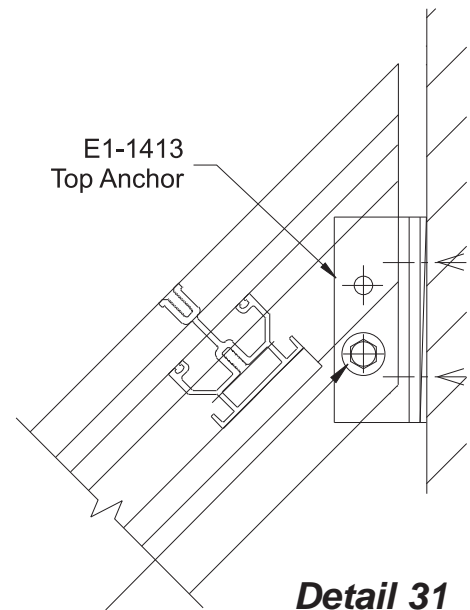

Detail 31

3/8"-16 x 3-1/2" HH bolt
Assemble with a flat washer,
lock washer, and nut

Continue installing the next intermediate rafter.
Repeat **Steps 18 & 19** across the sloped glazed wall until all purlins and rafters are installed and anchored.

Check the centerline to centerline dimension of rafters every fifth rafter to avoid accumulating dimensional error.

FRAME INSTALLATION

STEP 20 INSTALL ANCHOR HINGES

The 3/8" bolts in the anchor plates have been left finger tight in **Step 4**.

- Tighten the bolts to 50 inch pounds.
- Seal the fastener heads.

- Using each hole in the face of the anchor hinge as a guide, drill a .201" dia. hole through the ball of the anchor plate and the hinge.
 - Install a PC-1424 fastener into each hole drilled and secure the anchor hinge to the anchor plate.
- See **Detail 32**.

Note: Intermediate rafter anchor hinge E1-1405 has four holes.

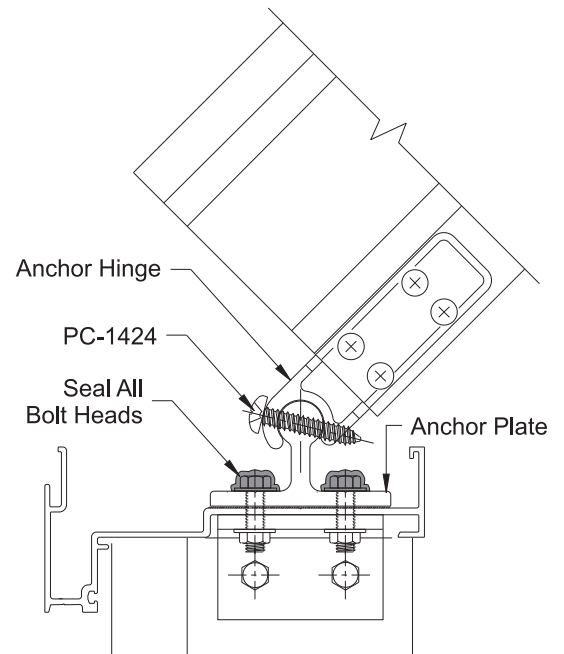

Detail 32

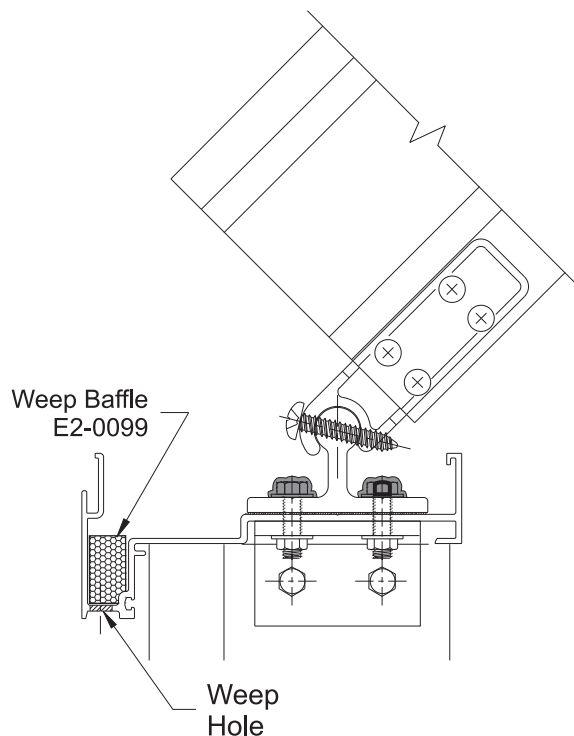

Detail 33

STEP 21 INSTALL WEEP BAFFLE

- Clean the gutter of all debris.
- Push a weep baffle, E2-0099, into the lower chamber of the gutter centered over each weep hole.

See **Detail 33**.

FRAME INSTALLATION

STEP 22 INSTALL POCKET FILLERS

- Run sealant in the outside gasket reglet of both jamb members and install pocket filler E9-5008.
- Run sealant in the outside gasket reglet of the top and bottom purlins and install pocket filler E9-5008. See **Details 34 & 35**.

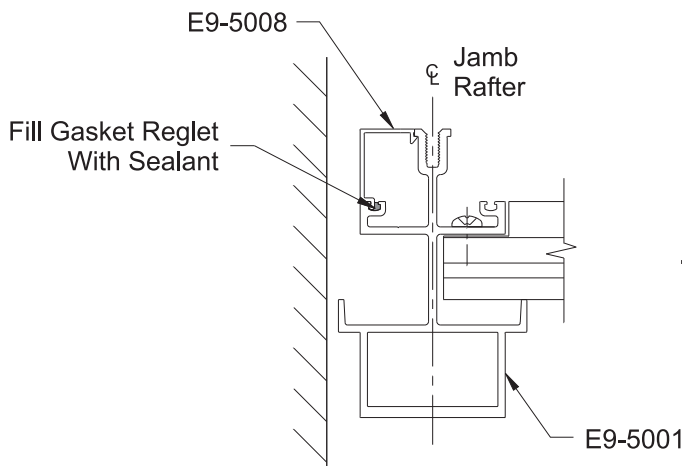

Detail 34

STEP 23 INSTALL INTERIOR GASKETS

Refer to the gasket selection table on the next page for the proper gasket usage.

- The rafter gaskets should be cut to the “G.L.” dimension, determined in **Step 8**, plus(+) 3/16” per foot of gutter length.
- The purlin gasket should be cut to daylight opening dimension of the purlins, determined in **Step 9**, plus(+) 3/16” per foot of daylight opening.
- Install all gaskets by first inserting each end of the gasket into the reglet.
- Next insert the gasket into the center of the reglet and then push in the remaining gasket working from the center towards each end.

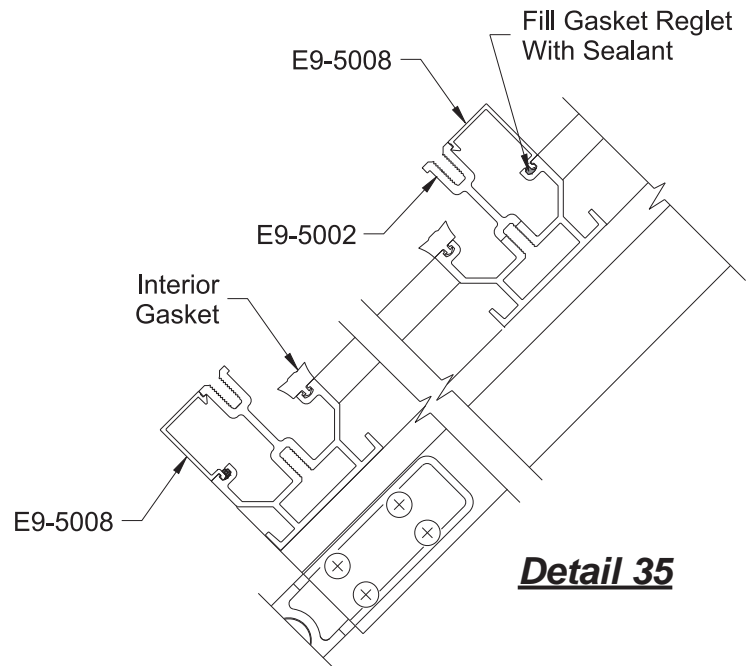

Detail 35

GASKET USAGE TABLE

GLASS THICKNESS

		5/16"	1"	1-1/16"	1-1/8"	1-3/16"	1-1/4"	1-5/16"
RAFTERS	Pressure Plate	AS-5004	AS-5004	AS-5004	AS-5004	AS-5004S	AS-5004S	AS-5004S
	Adaptor	E9-5012	None	None	None	None	None	None
	Inside Gasket	E2-0401	E2-0401	E2-0401	E2-0402	E2-0401	E2-0401	E2-0402
	Outside Gasket	E2-0400	E2-0400	E2-0400	E2-0400	E2-0400	E2-0400	E2-0400
CAPTURED GLAZED PURLINS	Pressure Plate	AS-5004	AS-5004	AS-5004	AS-5004	AS-5004S	AS-5004S	AS-5004S
	Adaptor	E9-5012	None	None	None	None	None	None
	Inside Gasket	E2-0401	E2-0401	E2-0401	E2-0402	E2-0401	E2-0401	E2-0402
	Outside Gasket	E2-0400	E2-0400	E2-0400	E2-0400	E2-0400	E2-0400	E2-0400
STRUCTURAL GLAZED PURLINS	Setting Block Base	E1-1411	E1-1411	E1-1411	E1-1411	E1-1412	E1-1412	E1-1412
	Adaptor	E9-5013	None	None	None	None	None	None
	Inside Gasket	E2-0414	E2-0414	E2-0414	E2-0415	E2-0414	E2-0414	E2-0415

FRAME INSTALLATION**STEP 24
SEAL GASKET INTERSECTIONS**

The intersection of the gasket for the rafter and the gasket for the purlin must be sealed to form a water tight corner.

- Pull out the last 3" of each end of each purlin gasket and fill the gasket reglet with sealant
 - Apply sealant to each end of the purlin gasket and reinsert the gasket.
 - Tool the excess sealant at all gasket intersections.
- See Details **36** & **37**.

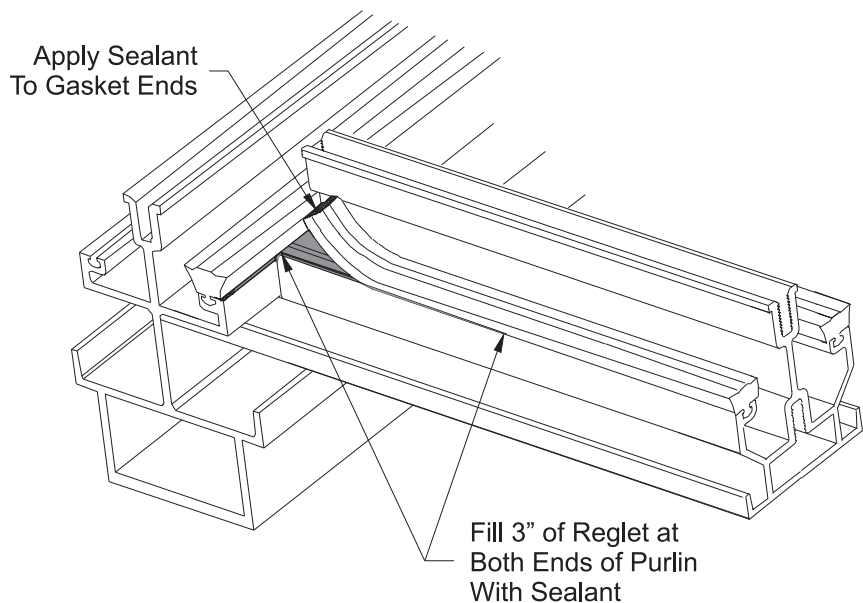
**Detail 36**

Captured purlin shown.
Structural silicone glazed purlin similar.

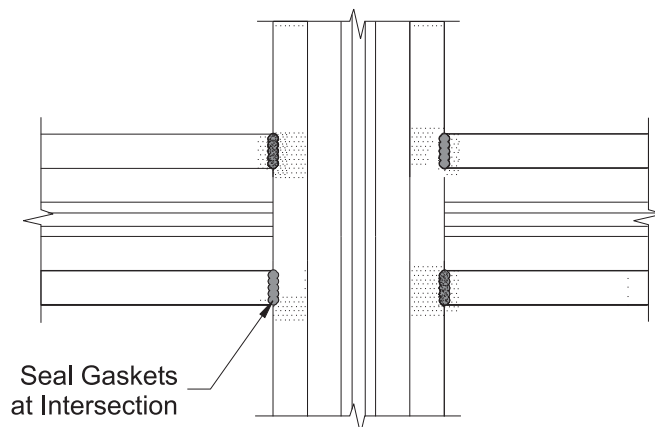
Detail 37

FRAME INSTALLATION

**STEP 25
INSTALL GUTTER TRANSITION CLOSURE**

- Mark on the end plate closures where the gutter transition closure will intersect it (gutter transition closures were fabricated in **Step 14**).
- Install transition cover with double faced tape.
- See **Detail 38**.

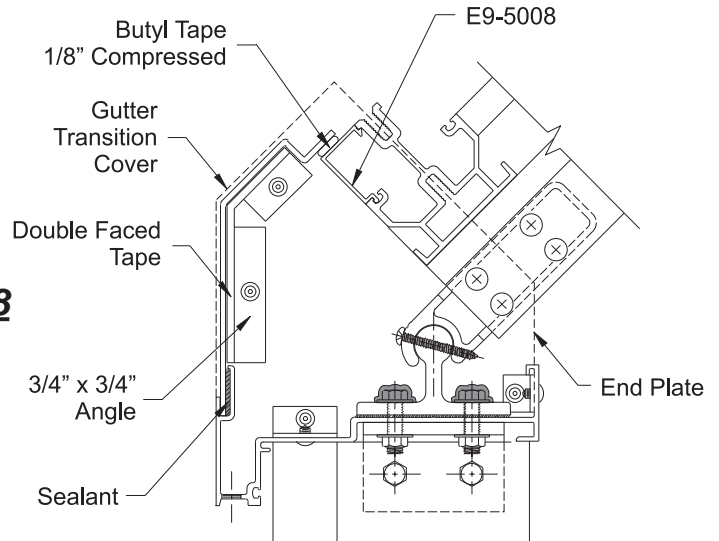

Detail 38

**STEP 26
SETTING BLOCK INSTALLATION**

Captured Glazed Purlins

- (Includes bottom purlins of applications with structural silicone glazed purlins)
- Install setting blocks E2-0405 at quarter points.
 - See **Detail 39**.

Structural Silicone Glazed Purlins

- Install setting block bases, E1-1411 or E1-1412, at 1/4 points on all structural glazed purlins. (See the Gasket Usage Table on Page 25 to determine which setting block base.)
- Fasten the setting block bases to the purlins with (2) PM-2510 fasteners per base.
- Install setting block E2-0408 onto the setting block base.
- See **Detail 40**.

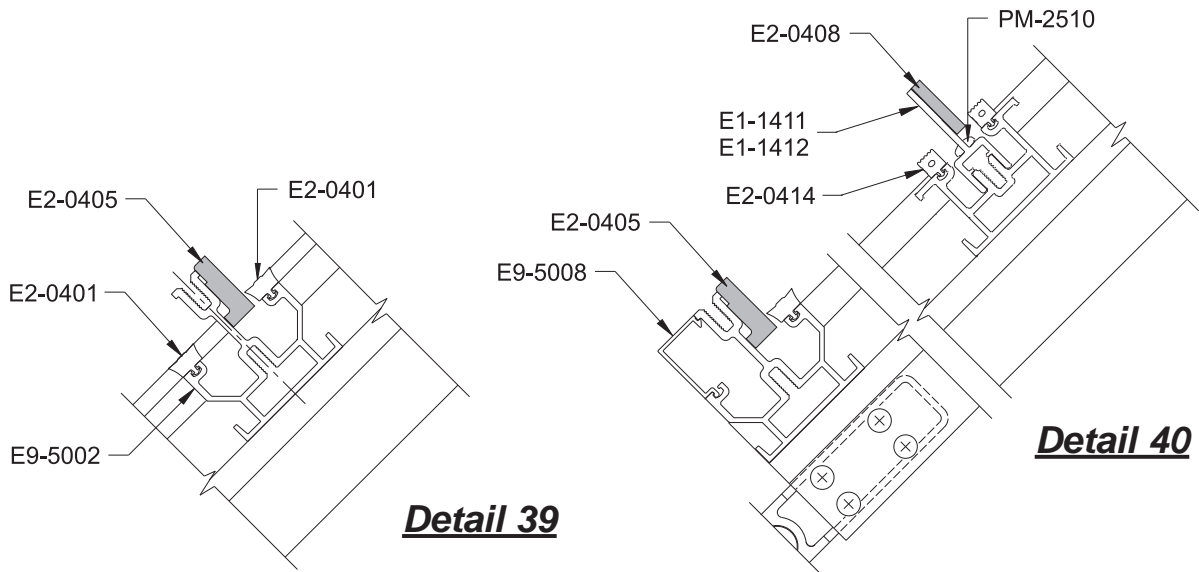

Detail 39

Detail 40

FRAME INSTALLATION

STEP 27 INSTALL SIDE BLOCKS

-Attach side blocks, E2-0407, to all rafters at the mid-point of each lite of glass.
(pressure sensitive tape will hold the side blocks in place)

See **Detail 41** and **42**.

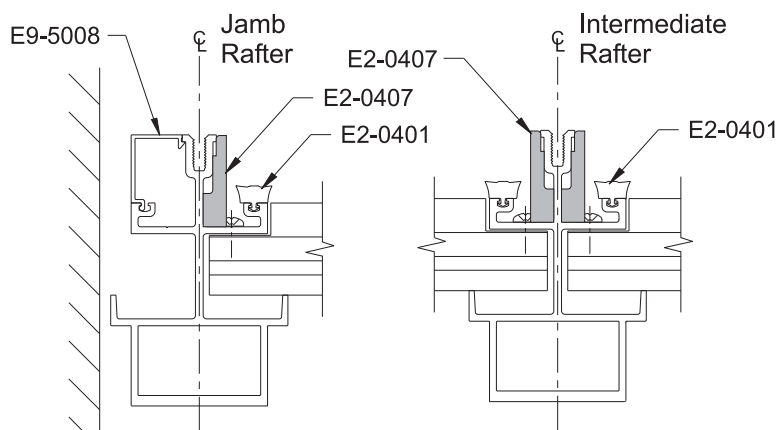

Detail 41

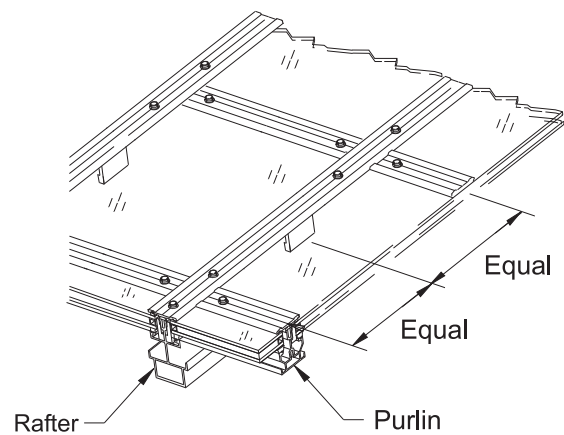

Detail 42

STEP 28 INSTALL GLAZING ADAPTORS

Rafter adaptors:

- Must be installed after you have installed the purlins.
- Apply small dabs of silicone sealant into the gasket reglets of the rafter.
- Align the ends of the adaptor with the ends of the gutter.
- Immediately install the adaptor into place (the silicone sealant is intended to hold the adaptor in place during the glazing operation).

See **Detail 43**.

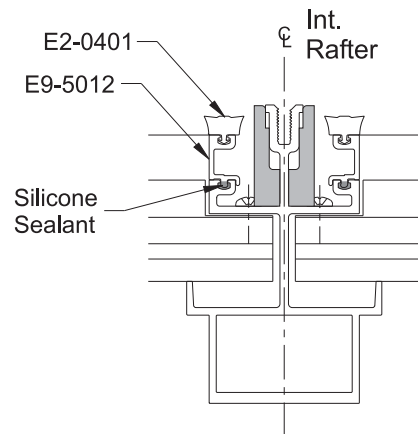

Detail 43

FRAME ASSEMBLY

STEP 28 (Continued) INSTALL GLAZING ADAPTORS

Captured Glazing Purlin Adaptors:

- Must be installed after you have installed the purlins.
- Apply small dabs of silicone sealant into the gasket reglet of the rafter.
- Align the ends of the adaptor with the ends of the gutter.
- Immediately install the adaptor into place (the silicone sealant is intended to hold the adaptor in place during the glazing operation).

See **Detail 44**.

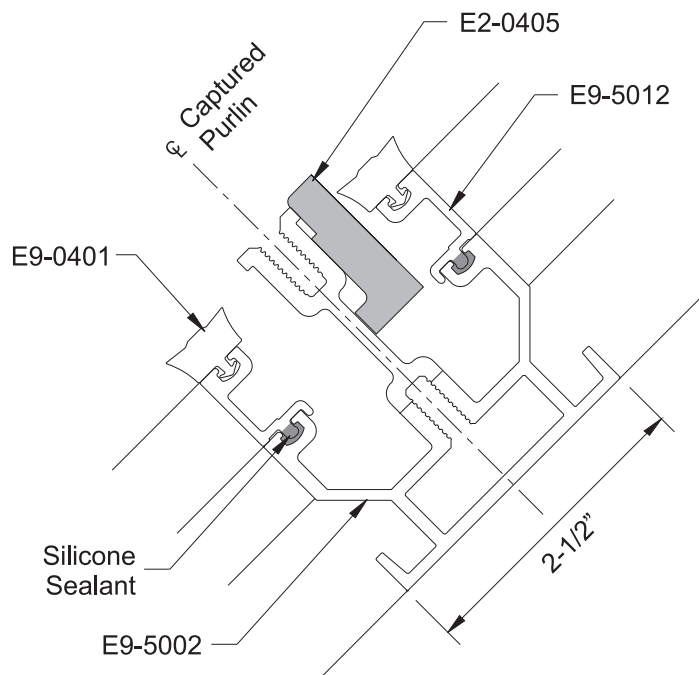

Detail 44

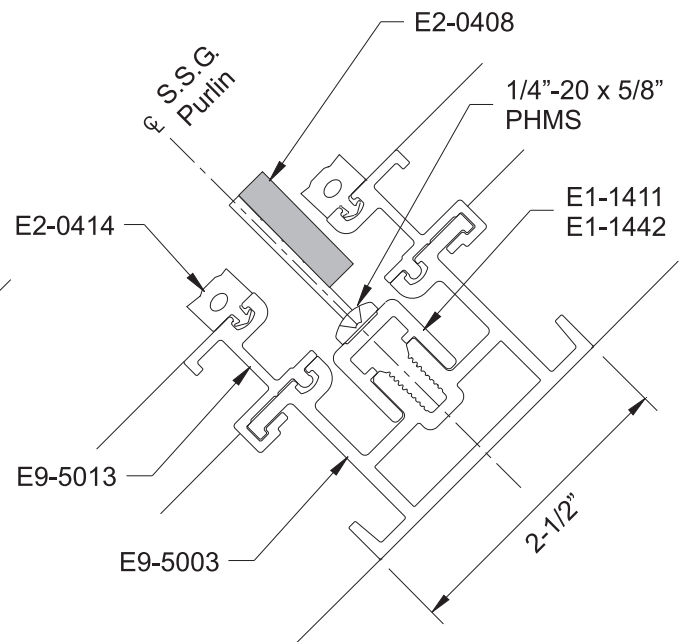

Detail 45

Structural Silicone Glazed Purlin Adaptors:

The adaptor must be slid onto the purlin before the purlin is attached to the rafter.

- Slide the adaptor onto the purlin.
- Center the adaptor on the purlin.
- Attach the purlin to the rafter.

See **Detail 45**.

GLAZING

STEP 29 INSTALL GLASS & RAFTER PRESSURE PLATES

Calculate Glass Sizes:

Type of Unit	Glass Width	Glass Height
Captured	D.L.O. + 1-1/4"	D.L.O. + 1-1/4"
Jamb to SSG	D.L.O. + 1-1/4"	D.L.O. + 1-9/16"
SSG to SSG	D.L.O. + 1-1/4"	D.L.O. + 1-7/8"

-Proceed to set the glazing to fill in each opening. Plan the setting pattern that you will follow so that you do not work yourself into a corner or a difficult setting position.

-Cut the exterior glazing gaskets to the length of the pressure plate and install them into the pressure plates. Check the Gasket Usage Table on Page 25 to ensure that you have ordered the correct exterior gaskets.

Note: The outboard leg of the jamb pressure plate receives gasket E2-0120.

As you proceed with the glazing operation:

- Center each pressure plate on the rafter.
- Install fasteners HM-2516 every 9" and a maximum of 1-1/2" from each end, starting in the center of each pressure plate and working towards each end.
- Torque all fasteners to 50 inch pounds.

See **Detail 46**.

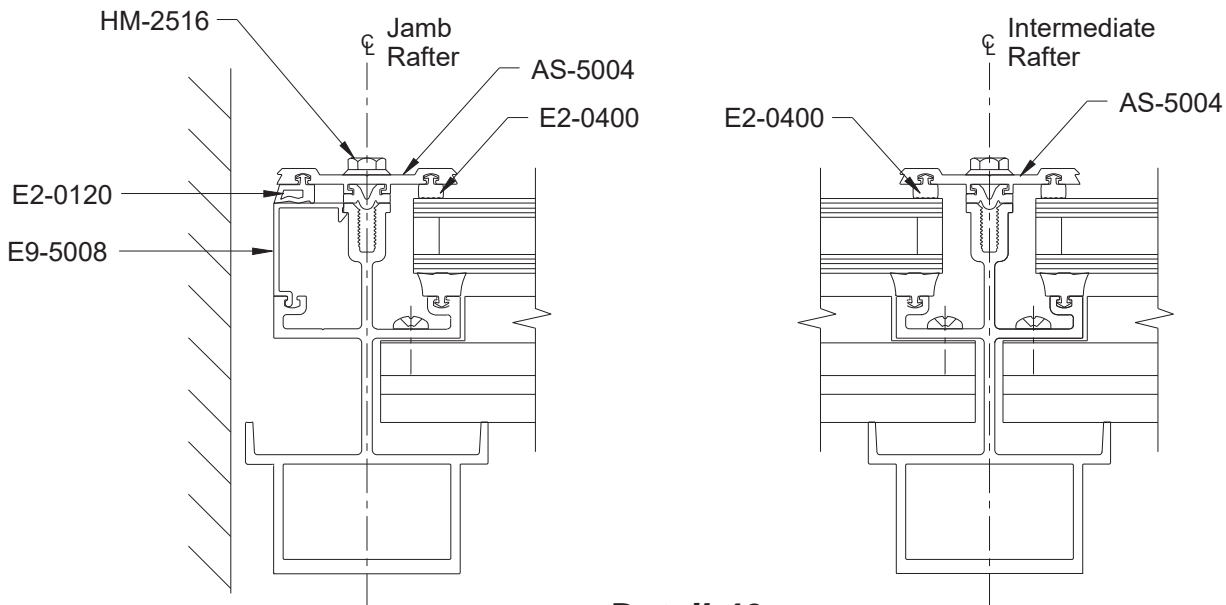

Detail 46

GLAZING

STEP 30 INSTALL PURLIN PRESSURE PLATES

As you proceed with the glazing operation:

- Center each pressure plate on the purlin (leaving a 1/16" gap at each end).
- Install fasteners HM-2516 every 9" and a maximum of 1-1/2" from each end, starting in the center of each pressure plate and working towards each end.
- Torque all fasteners to 50 inch pounds.

See **Detail 47**.

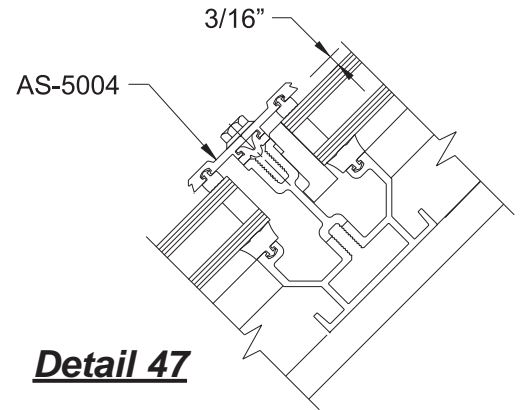

Detail 47

STEP 31 INSTALL TEMPORARY RETAINERS FOR SSG PURLINS

- Cut 4-1/2" pieces of pressure plate and install the proper gasket cut down to 4-1/2".
- Cut enough pieces of pressure plate to provide a temporary retainer for each purlin. Purlins longer than 48" will require a minimum of two temporaries per purlin spaced a maximum of 24" on center.
- Drill a 0.281" dia. (#9/32 drill bit) hole in the center of each four inch piece of pressure plate, or cut pressure plate using existing hole at each center.

See **Detail 48**.

-As you proceed with the glazing operation attach a temporary retainer to the purlin, a maximum of 24" on center, using a HM-2540 fastener (1/4"-20 x 2-1/2").

See **Detail 49**.

-Top and bottom purlins receive full pressure plates, see **Step 30**.

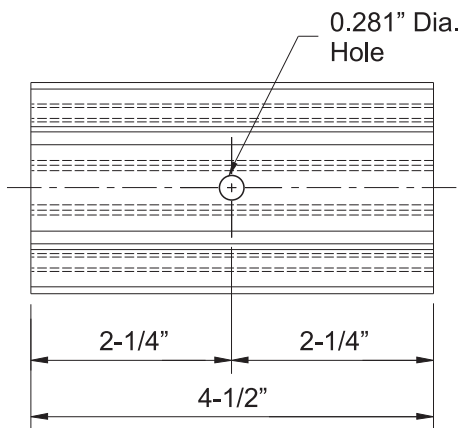

Detail 48

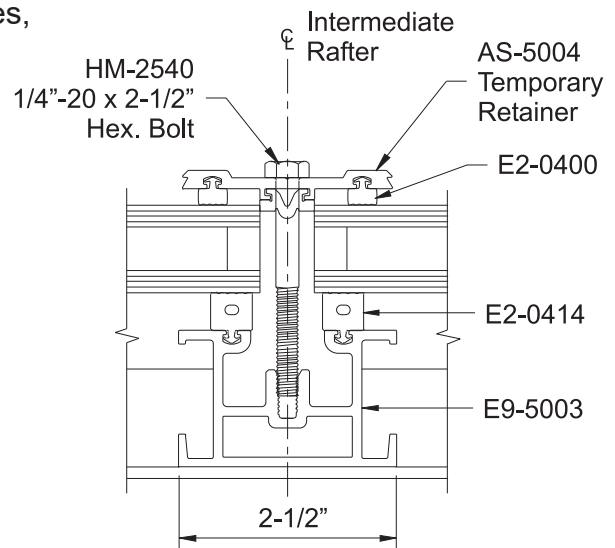

Detail 49

GLAZING

STEP 32

**APPLY INTERIOR STRUCTURAL SILICONE
(Structural Silicone Glazed Purlin Only)**

- Carefully read and follow all of the installation instructions from the structural silicone sealant manufacturer.
- Clean the glass and aluminum surfaces with a cleaner recommended by the structural silicone sealant manufacturer.
- Apply masking tape to the edge of the purlin and along the glass.
- Apply silicone sealant to the gap between the purlin and the glass.
 - Beginning at one end of the purlin apply positive pressure and pump in a sufficient quantity of silicone to completely fill the joint.
- Tool the silicone immediately after filling each joint:
 - Use a nylon spatula or other non-scratching implement to tool the silicone.
 - Use positive pressure while tooling to ensure that the silicone completely fills the joint and makes positive contact with all surfaces.
 - The finished silicone joint should be flush with the edge of the purlin.
- Once the silicone has been tooled, carefully and immediately remove the masking tape.

See **Detail 50**.

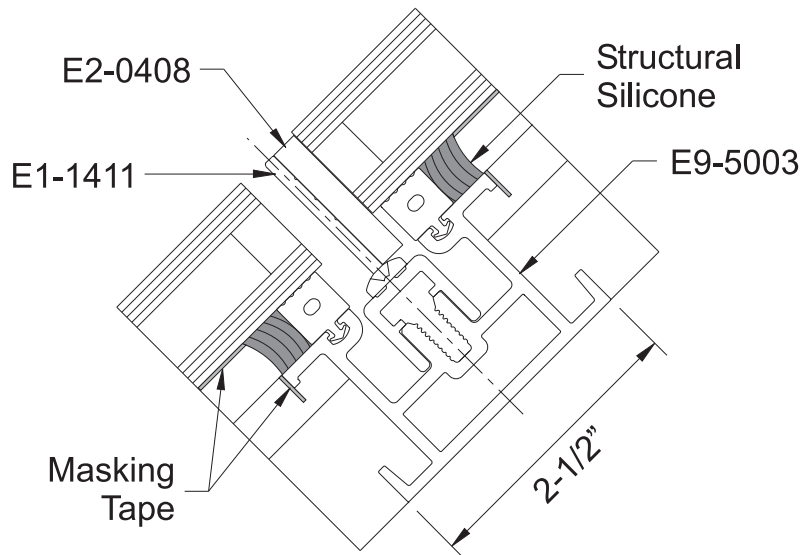

Detail 50

GLAZING

STEP 33 APPLY PRESSURE PLATE SEALANT

There is a 3/16" wide joint under the edges of each pressure plate that must be sealed using silicone sealant.

- Carefully read and follow all of the application instructions from the structural silicone sealant manufacturer.
 - Clean the glass and aluminum surfaces with a cleaner recommended by the structural silicone sealant manufacturer.
 - Apply masking tape to the edge of the pressure plate and glass.
 - Apply silicone to the joint between the pressure plate and the outside edge of the glass.
 - Beginning at one end of the pressure plate apply positive pressure and pump a sufficient quantity of silicone sealant to completely fill the joint.
- See **Detail 51**.

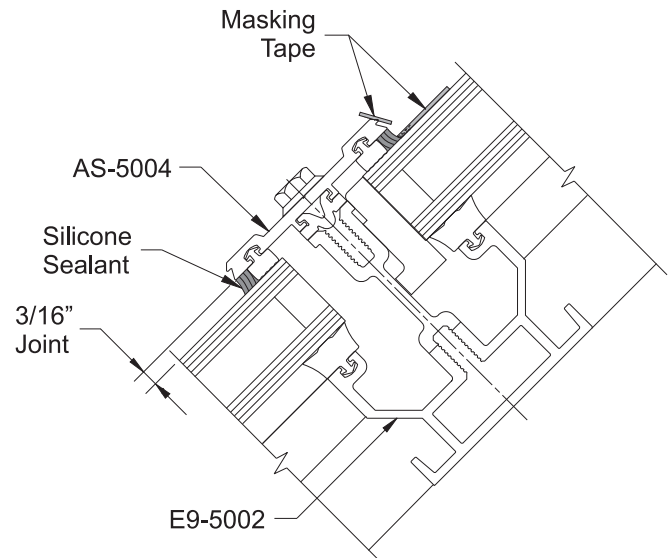

Detail 51

- Tool the silicone sealant immediately after filling each joint:
- Use a nylon spatula or other non-scratching implement to tool the silicone sealant.
- Use positive pressure while tooling to ensure that the silicone sealant completely fills the joint and makes positive contact with all surfaces.
- The finished silicone sealant joint should be flush with the edge of the pressure plate.
- Once the silicone sealant has been tooled, carefully and immediately remove the masking tape.
- Immediately remove any silicone that might interfere with the installation of the face covers.

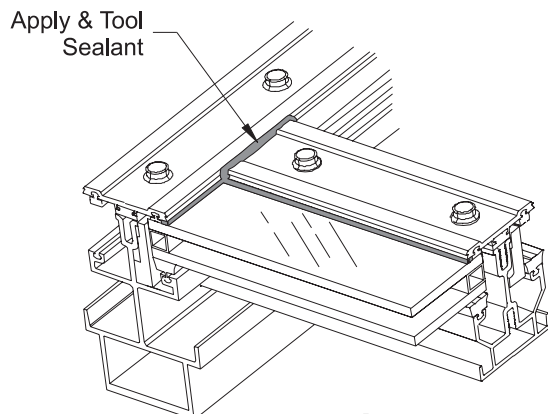

Detail 52

- Apply sealant to the joint between the purlin pressure plates and the rafter pressure plates.
- Tool the sealant to ensure a watertight seal.

See **Detail 52**.

GLAZING

STEP 34 APPLY EXTERIOR WEATHER SEAL FOR SILICONE STRUCTURAL GLAZED PURLINS

After the interior structural silicone has cured, typically a minimum of 21 days after application, remove the temporary retainer. Apply a weather seal to the 5/8" horizontal space between the lites of glass. Carefully read and follow all of the application instructions from the structural silicone manufacturer.

- Clean surfaces with a recommended cleaner.
- Apply masking tape to the edge of each glass lite.
- Fill the 5/8" gap between lites of glass with backer rod to a depth not to exceed 3/8".

See **Detail 53**.

Note: The area where the setting block shelf occurs, requires that a smaller backer rod be used under the setting block shelf to provide a back up for the silicone sealant.

See **Detail 54**.

- Apply silicone to the joint between the lites of glass.
- Beginning at one end, apply positive pressure and pump in a sufficient quantity of silicone sealant to completely fill the joint.
- Tool the silicone sealant immediately after filling each gap.
- Use a nylon spatula, or other non-scratching implement.
- Use positive pressure while tooling to ensure that the silicone completely fills the gap.
- The finished silicone joint should be flush with the edge of the glass.
- Once the silicone sealant has been tooled, carefully and immediately remove the masking tape.

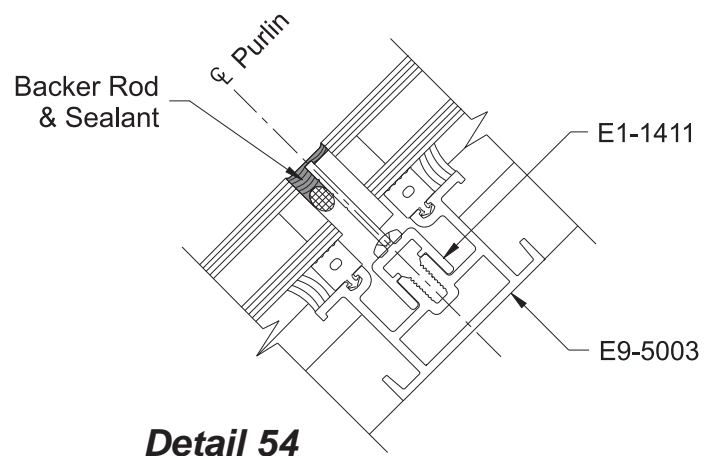
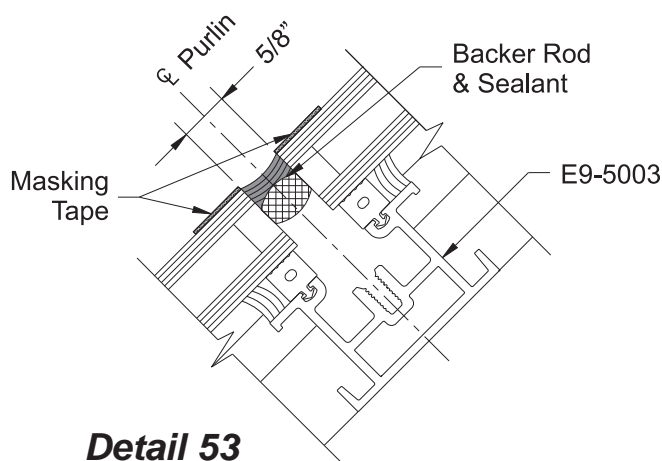

GLAZING

STEP 35 INSTALL RAFTER COVERS

- Align the lower end of the face covers with the lower end of the rafter pressure plate.
 - Use a wooden block and a rubber mallet to attach the face covers to the pressure plates. Start at one end and work block and mallet along until cover is snapped in place.
- See **Detail 55**.

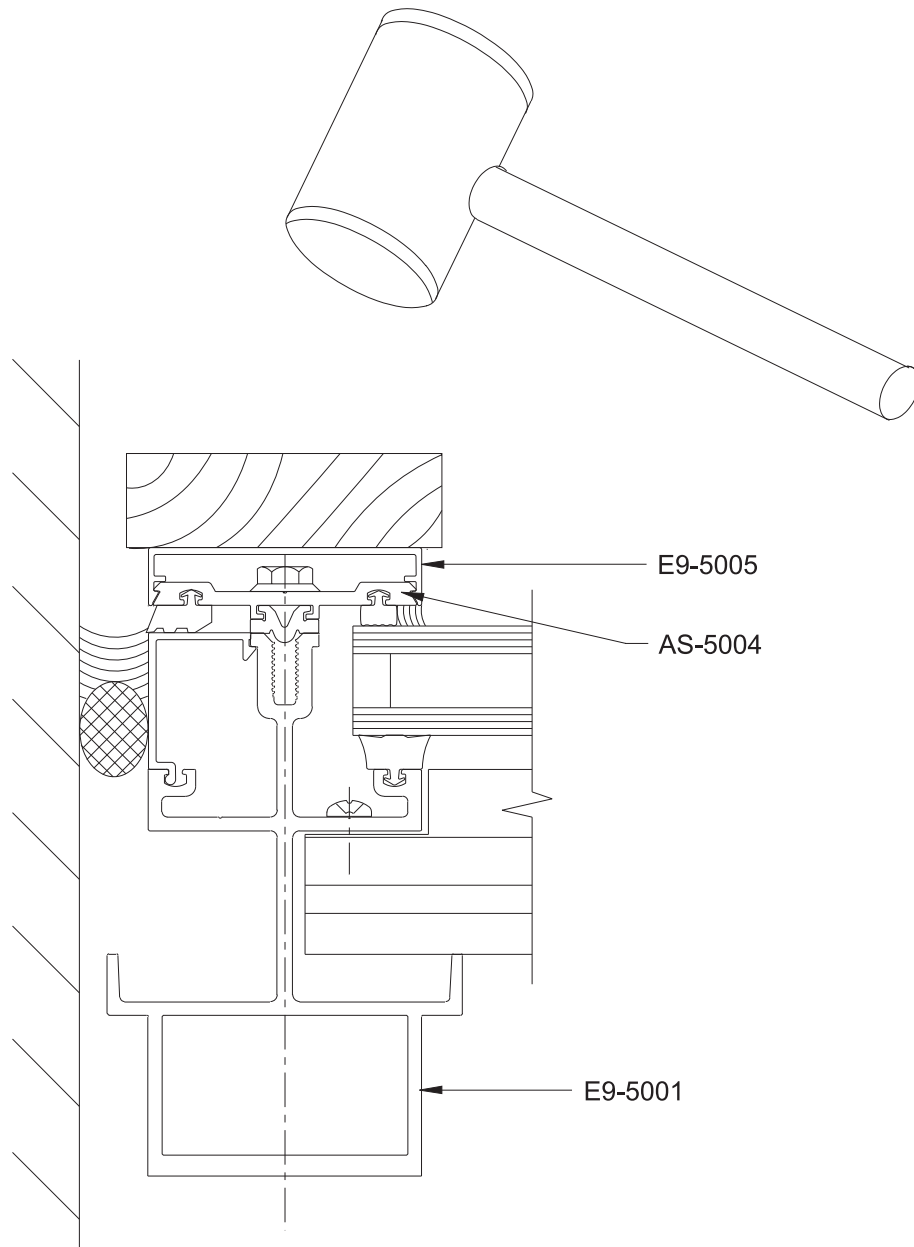

Detail 55

GLAZING

**STEP 36
INSTALL PURLIN COVERS**

There are three different covers for the purlins.
Refer to **Detail 56** to determine which covers are used at each location.

Proceed to install the covers just as they were in **Step 35**.

Purlin cover E9-5007 is spliced using E1-1416 splice sleeve.
See **Detail A**.

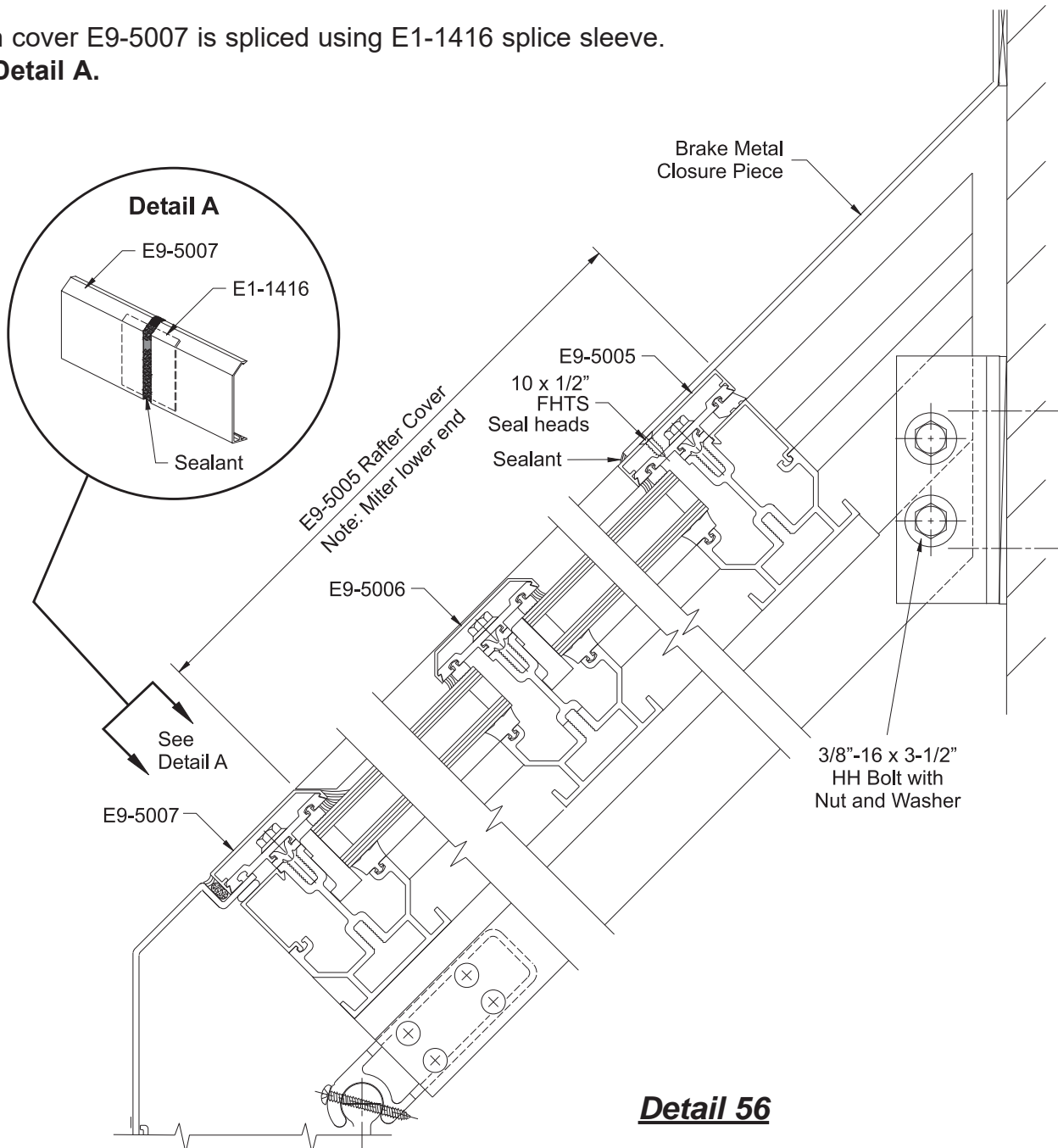

GLAZING

STEP 37 PURLIN TO STRUCTURE CLOSURE

The opening between the top of the YSK 750 Sloped Glazing System and the structure must be closed off with brake metal. The closure piece of brake metal must be designed such that the end will come down over the top purlin covers and will attach to the building as indicated in the shop drawings.

See **Detail 56**.

- Attach the brake metal closure to the structure as indicated in the shop drawings.
- Completely seal the bottom of the closure to the top purlin and rafter covers with perimeter sealant.

See **Detail 58**.

STEP 38 INSTALL GLASS STOPS

If your project has glazing below the gutter glass stops are required for that condition. Use glass stop E9-5010 with E9-5009 gutter; and E9-5020 with E9-5019 gutter.

- Cut all glass stops to the Daylight Opening minus(-) 1/32".
- See **Detail 57**.

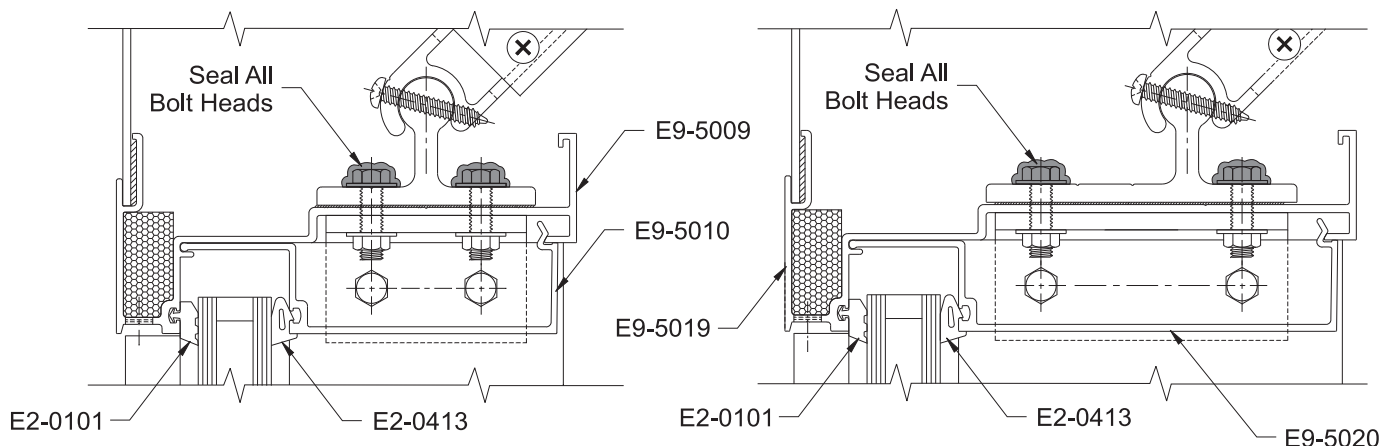

Detail 57

GLAZING

**STEP 39
APPLY PERIMETER SEALANT**

- Starting at the top cover plate of the jamb rafters, insert backer rod between the rafter and the structure as shown in **Detail 58**. Continue inserting backer rod down the rafter and along the outer edge of the end plate closures.
- Turn the backer rod to run along the bottom of the end plate closures until the YCW 750 (or other vertical wall) is intersected. From this point run the backer rod down to the sill.
- Apply perimeter sealant where the backer rod has been inserted.

See **Detail 58**.

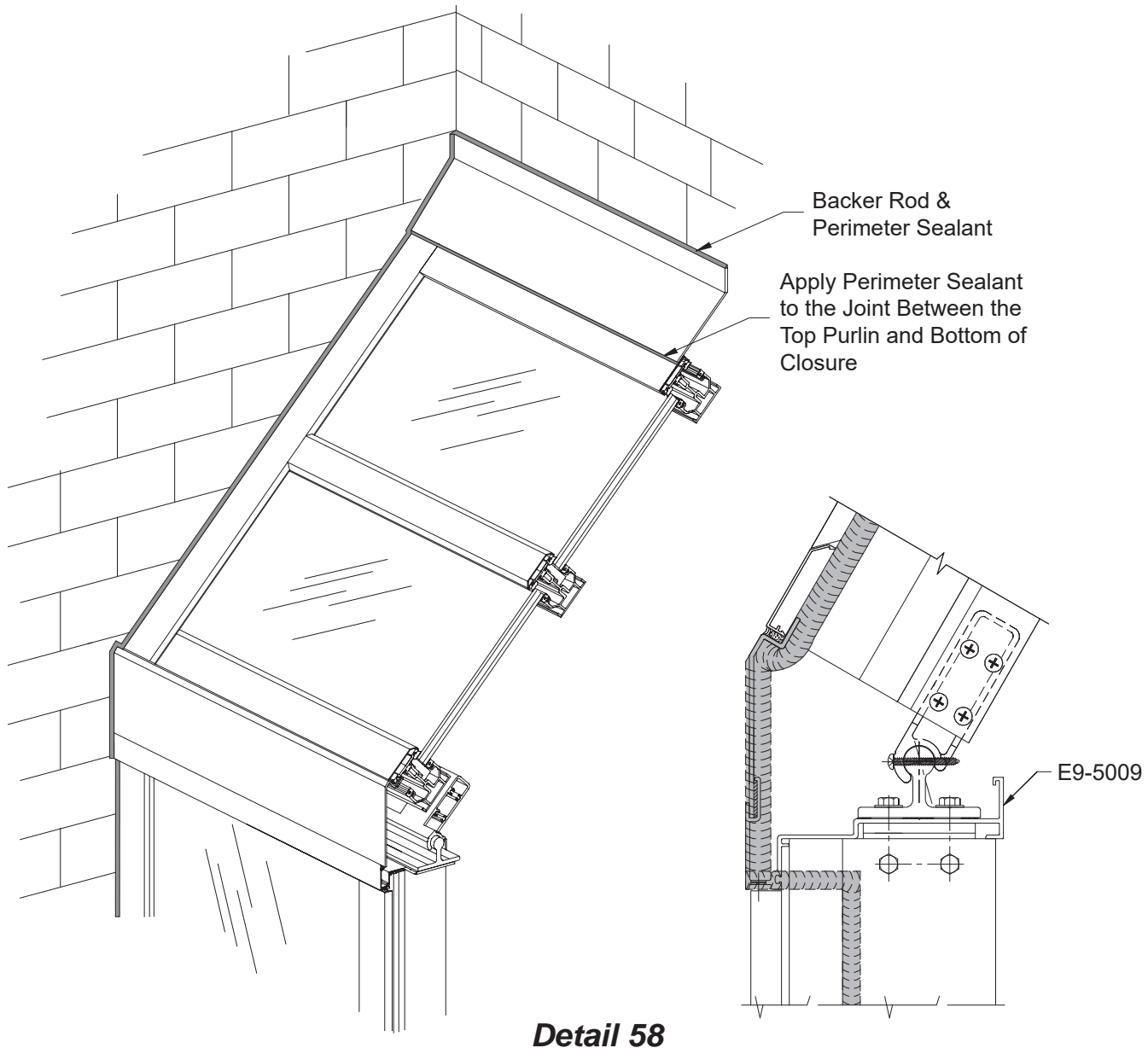

EXAMPLE RAFTER CALCULATIONS

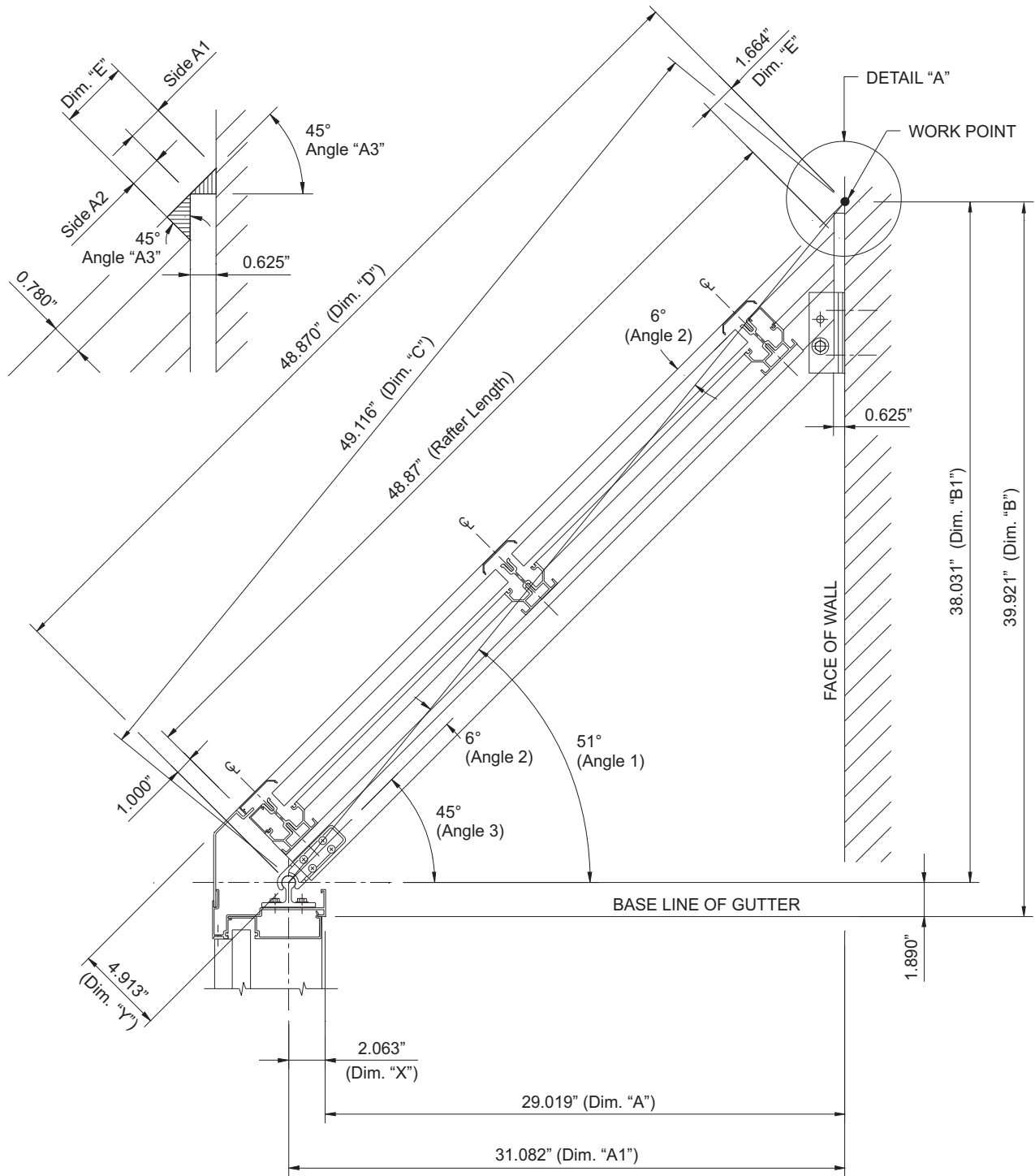

Detail 59

EXAMPLE RAFTER CALCULATIONS

RAFTER	DIM. "X"
E9-5001	2.063"
E9-5011	2.312"

Calculate Dimension "A1":

$$\begin{aligned} \text{Dim. "A1"} &= \text{Dim. "A"} + \text{Dim. "X"} \\ \text{Dim. "A1"} &= 29.019" + 2.063" \\ \text{Dim. "A1"} &= \underline{\underline{31.082"}} \end{aligned}$$

Calculate Dimension "B1":

$$\begin{aligned} \text{Dim. "B1"} &= \text{Dim. "B"} - 1.890" \\ \text{Dim. "B1"} &= 39.921" - 1.890" \\ \text{Dim. "B1"} &= \underline{\underline{38.031"}} \end{aligned}$$

Calculate Dimension "C":

$$\begin{aligned} \text{Dim. "C"} &= \sqrt{\text{Dim. "A1"}^2 + \text{Dim. "B1"}^2} \\ \text{Dim. "C"} &= \sqrt{31.082^2 + 38.031^2} \\ \text{Dim. "C"} &= \underline{\underline{49.116"}} \end{aligned}$$

Calculate Angle "1":

$$\begin{aligned} \tan \text{Angle "1"} &= \frac{\text{Dim. "B1"}}{\text{Dim. "A1"}} \\ \tan \text{Angle "1"} &= \frac{38.031}{31.082} \\ \text{Angle "1"} &= \underline{\underline{51^\circ}} \end{aligned}$$

Calculate Angle "2":

$$\begin{aligned} \sin \text{Angle "2"} &= \frac{\text{Dim. "Y"}}{\text{Dim. "C"}} \\ \sin \text{Angle "2"} &= \frac{4.913}{49.116} \\ \text{Angle "2"} &= \underline{\underline{6^\circ}} \end{aligned}$$

Calculate Angle "3":

$$\begin{aligned} \text{Angle "3"} &= \text{Angle 1} - \text{Angle 2} \\ \text{Angle "3"} &= 51^\circ - 6^\circ \\ \text{Angle "3"} &= \underline{\underline{45^\circ}} \end{aligned}$$

Calculate Side "A1" & Side A2:
(See Detail "A")

$$\begin{aligned} \cos \text{Angle "3"} &= \frac{0.625}{\text{Side A1}} \\ \cos 45^\circ &= \frac{0.625}{\text{Side A1}} \\ \text{Side A1} &= \frac{0.625}{\cos 45^\circ} \\ \text{Side A1} &= \underline{\underline{0.884"}} \end{aligned}$$

$$\begin{aligned} \tan \text{Angle "3"} &= \frac{\text{Side A2}}{0.780} \\ \tan 45^\circ &= \frac{\text{Side A2}}{0.780} \\ \text{Side A2} &= \tan 45^\circ \times 0.780 \\ \text{Side A2} &= \underline{\underline{0.780"}} \end{aligned}$$

Calculate Dimension "E":

$$\begin{aligned} \text{Dim. "E"} &= \text{Side A2} + \text{Side A1} \\ \text{Dim. "E"} &= 0.780 + 0.884 \\ \text{Dim. "E"} &= \underline{\underline{1.664"}} \end{aligned}$$

RAFTER	DIM. "Y"
E9-5001	4.913"
E9-5011	6.338"

Calculate Dimension "D":

$$\begin{aligned} \text{DIM "D"} &= \sqrt{\text{DIM "C"}^2 - \text{DIM "Y"}^2} \\ \text{DIM "D"} &= \sqrt{49.116^2 - 4.913^2} \\ \text{DIM "D"} &= \sqrt{2388.244} \\ \text{DIM "D"} &= \underline{\underline{48.87"}} \end{aligned}$$

Calculate "Rafter Length":

$$\begin{aligned} \text{Rafter Length} &= \text{Dim. "D"} - \text{Dim. "E"} - 1.000" \\ \text{Rafter Length} &= 48.87" - 1.664" - 1.000" \end{aligned}$$

Rafter Length = 46.206"



270 Riverside Parkway
Suite 100
Austell, Georgia 30168
www.ykkap.com