

YCW 750 SSG Structural Silicone Glazed Curtain Wall System

4 Side SSG Field Glazed

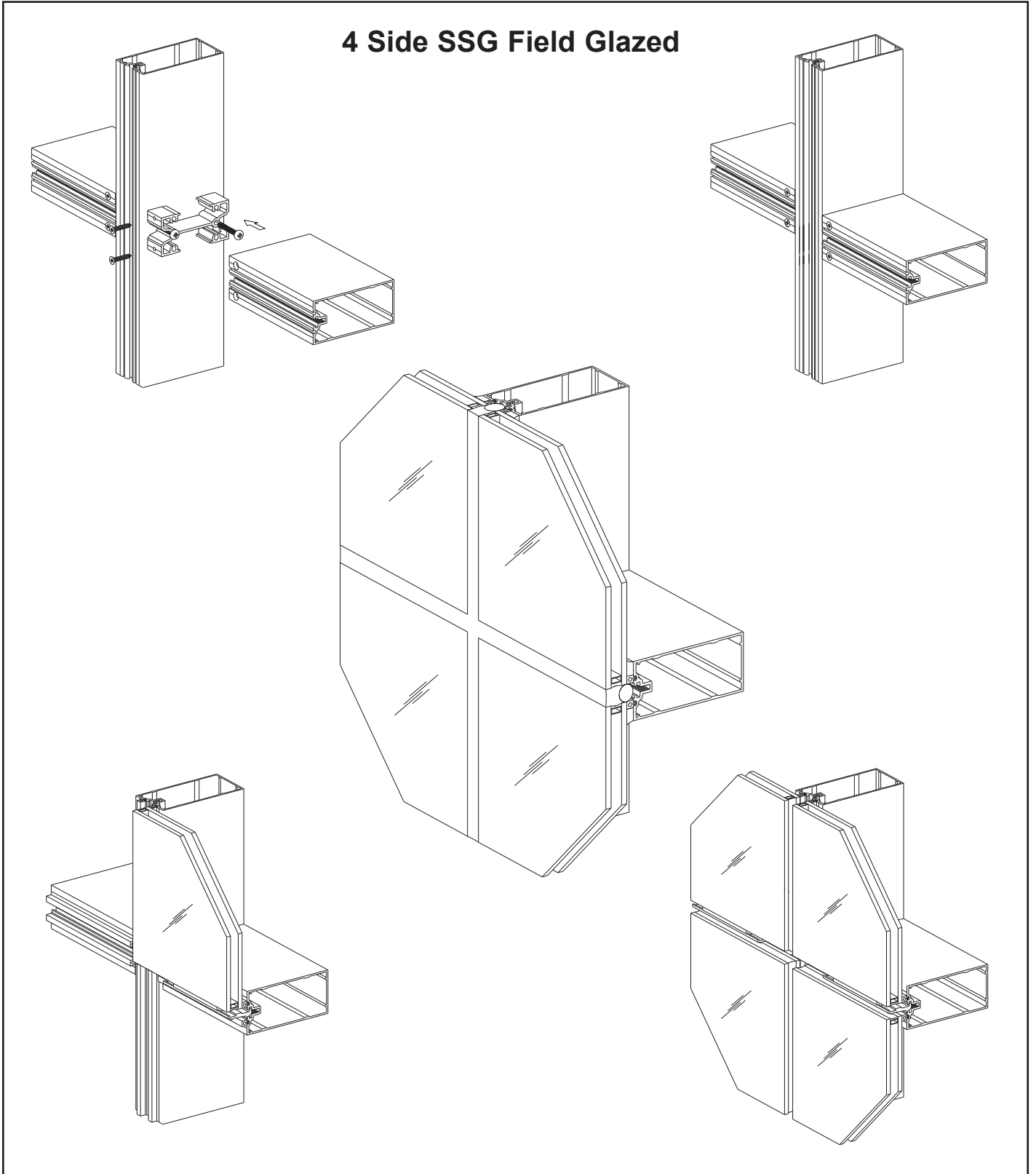

Installation Manual

TABLE OF CONTENTS

Installation Notes	Page ii
Important Notice	Page iii
PARTS DESCRIPTION	
YCW 750 SSG Framing Members	Page 1 & 2
YCW 750 SSG Accessories	Pages 2 to 4
FRAME FABRICATION	
Anchoring Methods/Framing Types.....	Page 5 & 6
Fabricate Mullions	Page 7 & 8
Using Alternate Reinforcing.....	Page 9
Attach Mullion End Caps	Page 10
Attach Shear Blocks/Clips for Horizontals.....	Page 11
Fabricate Horizontal Members	Page 12
Fabricate Perimeter Trim.....	Page 13
Fabricate Corner Glazing Adaptor.....	Page 14
FRAME INSTALLATION	
Jamb/Mullion Installation with Mullion End Anchors	Pages 15 & 16
Typical Mullion Splice	Page 17
Install Wind Load / Dead Load Anchors.....	Page 19 to 21
Attach Horizontal Members	Pages 21 to 23
Apply Perimeter Sealant.....	Page 24
GLAZING	
Install Glazing Adaptors.....	Page 25
Install Interior Glazing Spacers	Page 26
Attach Perimeter Trim.....	Pages 27 to 32
Install Jamb Subframes	Page 33
Install Setting Block Chairs and Setting Blocks.....	Page 34
Install Glass	Page 35
Apply Interior Structural Silicone Sealant.....	Page 36
Apply Exterior Weatherseal	Page 37
Install Perimeter Rainscreen Seals	Page 38

Installation Notes

1. Do not drop, roll or drag boxes of aluminum framing. Move and stack boxes with proper support to prevent distortion. If fork lifts are used be especially careful about striking the boxes when lifting or moving.
2. Store in a dry, out of the way area. If rain exposure, condensation or any water contact is likely, then all packaging material should be removed. Wet packaging materials will discolor and may stain aluminum finishes and paints.
3. All materials should be checked for quality and quantity upon receipt, YKK AP must be notified immediately of any discrepancies in shipment. Check to make sure that you have the required shims, sealants, supplies and tools necessary for the installation.
4. Carefully check the openings and surrounding conditions that will receive your material. Remember, if the construction is not per the construction documents, it is your responsibility to notify the general contractor in writing. Any discrepancies must be brought to the general contractor's attention before you proceed with the installation.
5. Gather your shop drawings, materials, packing list, and this installation manual. Carefully review parts location, the sequence it goes therein, when you glaze it and how you seal it. Installation instructions are of a general nature and may not cover every condition you will encounter. The shop drawings and/or installation manuals were prepared specifically for the product.
6. Any material substitutions must be of equal or greater quality.
7. Make certain that material samples have been sent for compatibility testing for all manufacturer's sealants involved. Make certain sealants have been installed in strict accordance with the manufacturer's recommendations and specifications.
8. Remember to isolate, in an approved manner, all aluminum from uncured masonry or other incompatible materials.
9. System-to-structure fasteners are not supplied by YKK AP. Fasteners called out on shop drawings are to indicate minimum sizes for design loading.
10. If any questions arise concerning YKK AP products or their installation, contact YKK AP for clarification before proceeding.
11. YKK AP storefront and/or curtain wall framing is typically completed before drywall, flooring and other products which may still be in process. Take the extra time to wrap and protect the work produced.
12. Cutting tolerances are plus zero, minus one thirty second unless otherwise noted.
13. Check our website, www.ykkap.com, for the latest installation manual update prior to commencing work.

Important Notice for SSG Curtain Wall Systems:

In order to properly perform and to maintain structural integrity, in addition to all other installation requirements, structurally glazed curtain wall systems rely specifically upon effective and appropriate structural sealant selection and installation.

It is the responsibility of the glazing contractor to take all steps to ensure the installed structural sealant is capable of meeting all applicable project requirements in accordance with industry standards. Such steps on each project may include, but are not limited to, design reviews, formal adhesion testing, project specification compliance, validating applications, field testing, auditing, sealant design strength analysis, and the quality control review of the installation and surrounding conditions.

Subject to project specific design pressures, requirements, and/or specifications, the structural sealant that is used between the glass and framing system must be capable of withstanding tensile and shear stresses imposed by the curtain wall without failing adhesively or cohesively.

The structural sealant's capability to withstand these stresses are dependent on several factors including, but not limited to, type of structural sealant, method of application (i.e. cleaning, primer), construction of glazing material (i.e. insulating glass unit (IGU), other infill, and finish of framing (i.e. anodizing, paint).























- Adhesive failure occurs when sealant pulls away from substrate cleanly, leaving no sealant material behind.
- Cohesive failure occurs when sealant breaks or tears within itself but does not separate from each substrate because sealant-to-substrate bond strength exceeds sealant's internal strength.

The IGU and/or other infill must be constructed for installation into structurally sealant glazed curtain walls. Notify the manufacturer or fabricator of the IGU and/or infill and advise of the product's application into 2 or 4-sided structurally sealant glazed curtain walls along with the project's design requirements so that appropriate fabrication steps are taken.

Secondary Notice for SSG Curtain Wall Systems:

Standard product details and system offering supports single and twin span applications only. For multi-span applications or elevation configurations that require the application of vertical expansion components, please contact YKK AP engineering for review.

FRAMING MEMBERS

	Vertical / Horizontal 2-1/2" x 8-1/4"	E9-3430		Horizontal Flush Filler Use with E9-3403	E9-3162
	Vertical / Horizontal 2-1/2" x 6-3/4"	E9-3426		Horizontal Flush Filler Use with E9-3424	E9-3595
	Vertical / Horizontal 2-1/2" x 5-1/4"	E9-3402		Perimeter Trim	E9-3409
	Vertical / Horizontal 2-1/2" x 3-3/4"	E9-3423		90° Outside Corner SSG Mullion Adaptor	E9-3413
	Vertical Heavy Duty 2-1/2" x 5-1/4"	E9-3401		Corner Trim	E9-3414
	Head/Sill/Horizontal Open Back 2-1/2" x 8-1/4"	E9-3431		90° Outside Corner Interior Cover Base Use with E9-1281	E9-1280
	Head/Sill/Horizontal Open Back 2-1/2" x 6-3/4"	E9-3428		90° Outside Corner Interior Cover	E9-1281
	Head/Sill/Horizontal Open Back 2-1/2" x 5-1/4"	E9-3403		Single Acting Transom Bar Elastomer Weathering E2-0051 Included	AS-0402
	Head/Sill/Horizontal Open Back 2-1/2" x 3-3/4"	E9-3424		Door Jamb Adaptor Use with AS-0417	E9-2344
	Horizontal Flush Filler Use with E9-3431	E9-3188		Snap-In Door Stop Elastomer Weathering E2-0051 Included Use with E9-2344	AS-0417
	Horizontal Flush Filler Use with E9-3428	E9-8489		Glazing Adaptor For 1/4" Glazing (SSG Mullions)	E9-3421











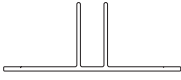









FRAMING MEMBERS

	<p>Vertical Glazing Adaptor For 1/4" Glazing (SSG Mullions)</p>	<p>E9-3422</p>	
--	--	-----------------------	--





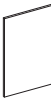

ACCESSORIES

	<p>Standard Shear Block For 3-3/4" Depth Members Use (2) PF-2528 & (2) FC-1212</p>	<p>E1-3425</p>		<p>Perimeter Trim Clip E1-3543</p>
	<p>Standard Shear Block For 5-1/4" to 8-1/4" Depth Members Use (2) PF-2528 & (2) FC-1212</p>	<p>E1-3542</p>		<p>End Cap For Perimeter Trim E1-3579</p>
	<p>RH Shear Clip For 90° Corner</p>	<p>E1-3540A</p>		<p>Intermediate Vertical "T" End Anchor* For E9-3423 E1-1229</p>
	<p>LH Shear Clip For 90° Corner</p>	<p>E1-3540B</p>		<p>Intermediate Vertical "T" End Anchor* For E9-3401 E1-1222</p>
	<p>Mullion Joint Sleeve For E9-3401 and E9-3402</p>	<p>E1-3548</p>		<p>Intermediate Vertical "T" End Anchor* For E9-3402 E1-1208</p>
	<p>Mullion Splice Sleeve For E9-3426</p>	<p>E1-3427</p>		<p>Intermediate Vertical "T" End Anchor* For E9-3426 E1-3580</p>
	<p>Mullion Splice Sleeve For E9-3430</p>	<p>E1-3566</p>		<p>Intermediate Vertical "T" End Anchor* For E9-3430 E1-3568</p>
	<p>Spacer For 90° Corner Use With E1-3411</p>	<p>E1-3550</p>		<p>Corner Vertical "T" End Anchor* For E9-3423 E1-1229A</p>
	<p>Setting Block Chair</p>	<p>E1-3545</p>		<p>Corner Vertical "T" End Anchor* For E9-3401 E1-1222A</p>

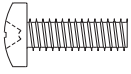
ACCESSORIES

	Corner Vertical "T" End Anchor* For E9-3402	E-1208A		Wind Load Anchor* Refer to Shop Drawings For Anchor Dimensions	E1-1204
	Corner Vertical "T" End Anchor* For E9-3426	E1-3580A		Dead Load Anchor* Refer to Shop Drawings For Anchor Dimensions	E1-1205
	Corner Vertical "T" End Anchor* For E9-3430	E1-3568A		Jamb Anchor Plate	E1-3536
	Jamb "F" End Anchor* For E9-3423	E1-1230		Steel Reinforcing 2" x 4" x 1/4" Steel Tube	E1-0162
	Jamb "F" End Anchor* For E9-3401	E1-1234		Steel Reinforcing 2" x 4" x 1/4" Steel Tube & (2) 1/4" x 1-3/4" Steel Bars	E1-0154
	Jamb "F" End Anchor* For E9-3402	E1-1233		Silicone Splice Sleeve	E2-0070
	Jamb "F" End Anchor* For E9-3426	E1-3581		Glazing Spacer Tape	E2-0110
	Jamb "F" End Anchor* For E9-3430	E1-3569		SSG Glazing Spacer	E2-0261
	SSG Mullion End Cap Stainless Steel	FW-2500-SS		Weep Tube	E3-0102
	Setting Block With Pressure Sensitive Adhesive Use With E1-3545	E2-0224		Nylon Slip Pad For Wind Load & Dead Load Anchor	E3-0103
	Temporary Glass Retainer 2" Long	E1-1294			

FASTENERS

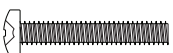
	<p>#12 x 5/8" PHSMS Type AB, Zinc Plated Steel For Attachment of End Cap to Perimeter Trim</p>	<p>PC-1210</p>		<p>1/4"-20 x 3/4" PHMS Stainless Steel For Attachment of Perimeter Trim Clip to Mullion</p> <p>PM-2512-SS</p>
	<p>#12 x 3/4" FHSMS Type AB Zinc Plated Steel, For Attachment of Horizontal to Shear Block (Exposed Fastener)</p>	<p>FC-1212</p>		<p>#10 x 3/8" PHMS Stainless Steel For Attachment of Perimeter Trim Clip to Perimeter Trim</p> <p>PM-1006-SS</p>
	<p>#14 x 5/8" FHSMS Type AB Zinc Plated Steel, For Attachment of FW-2500-SS Mullion End Cap to Mullion</p>	<p>FC-1410</p>		<p>#10 x 1-1/4" FHSMS Type AB, Zinc Plated Steel For Attachment of Optional Glazing Adaptors</p> <p>FC-1020</p>
	<p>1/4-20 x 1-3/4" LG Type F Zinc Plated Steel, For Attachment of Mullion to Shear Block</p>	<p>PF-2528</p>		<p>1/4"-20 x 2-1/2" PHMS Stainless Steel For Attachment of Temporary Glass Retainer</p> <p>PM-2540-SS</p>

FRAME FABRICATION

FRAME TYPES / ANCHORING METHODS

The following is a guideline for common types of frames. Refer to shop drawings for exact layout of frames.

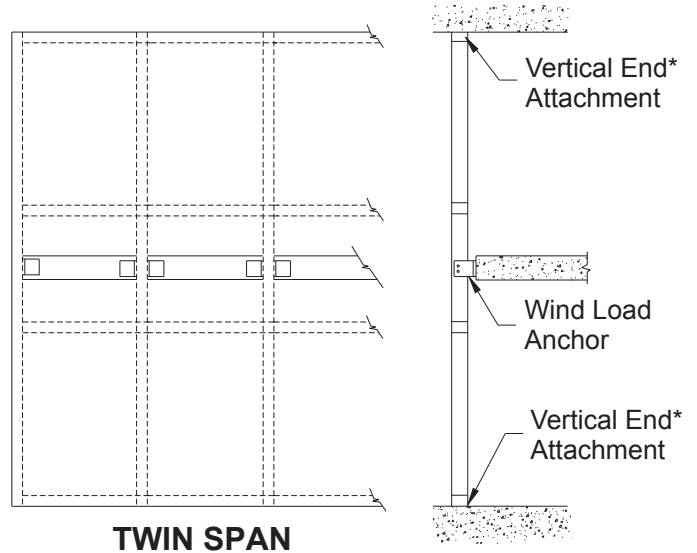
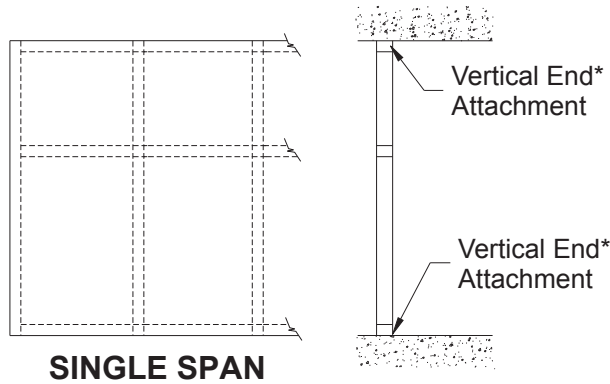

Smaller units may be assembled on the ground and lifted into place. Larger units require being stick assembled in place.

Note: If YKK AP does not prepare the shop drawings for the project, a qualified engineer must approve all anchors and mullions for wind load and dead load.

All anchors must be attached to structurally sound material that will accommodate the anchor reactions.

FRAME FABRICATION

FRAME TYPES / ANCHORING METHODS

Mullions can be pre-assembled with shear blocks/clips, end anchors, and steel or aluminum reinforcing if necessary.

Framing Members for Stick Build:

- Tubular horizontal members are used at all intermediate locations except at end bays.
- Open back intermediate horizontals are used at end bays to clear the shear blocks.

Note: When using stick build construction, check overall frame width every fifth mullion as the wall is installed to prevent the buildup of cumulative tolerance errors. Mullions must be installed plumb, horizontals must be installed level.

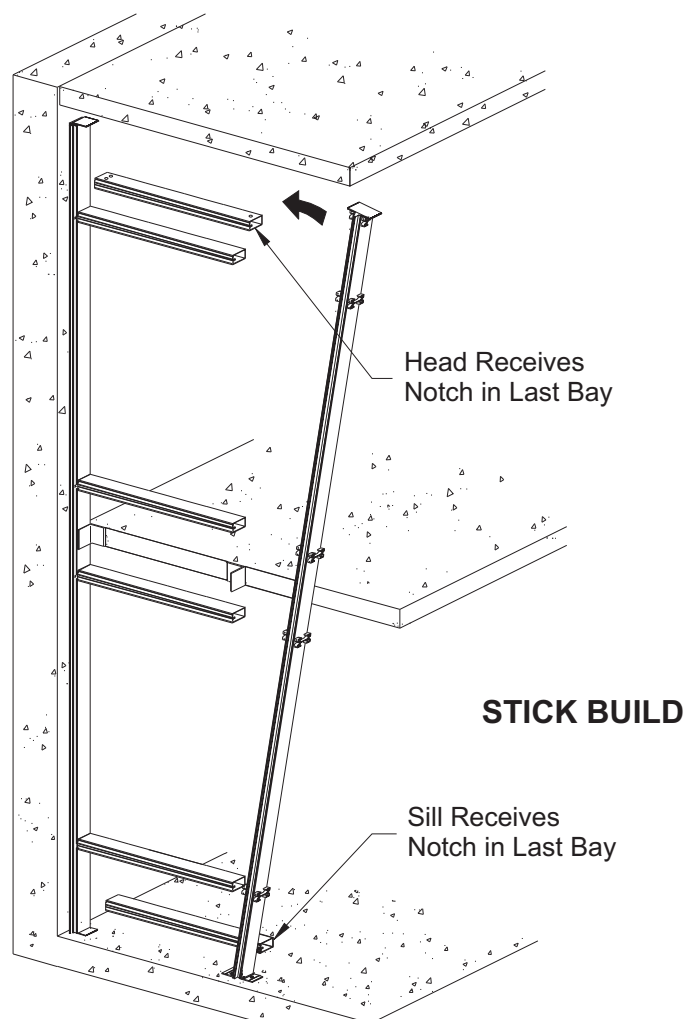

FRAME FABRICATION

STEP 1 FABRICATE MULLIONS

- Mullion hole locations for shear blocks are shown below.
 - Drill 0.213" dia. (#3 drill bit) holes for shear block attachment at the locations indicated.
- See **Detail 1**.

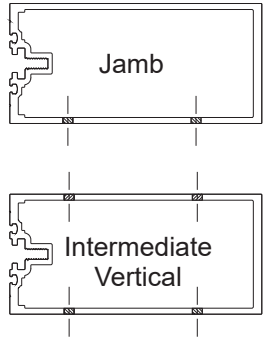

Dim "A"	Dim "B"
6-3/4"	2-3/4"
5-1/4"	2-3/4"
3-3/4"	1-1/2"

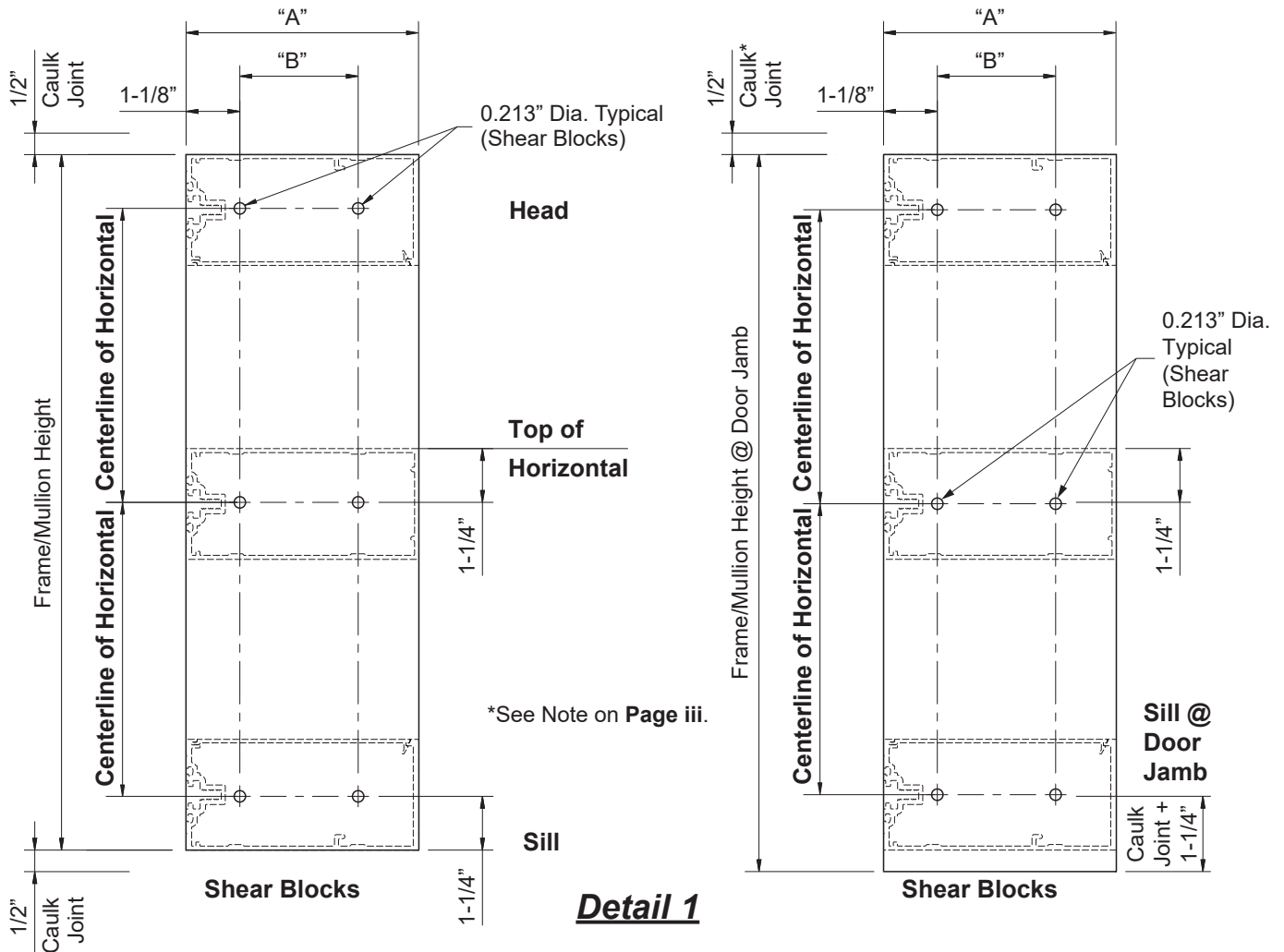

FRAME FABRICATION

STEP 1 (Continued) FABRICATE 90° OUTSIDE CORNER MULLIONS

- Mullion hole locations for shear blocks are shown below.
- Drill 0.213" dia. (#3 drill bit) holes for shear block attachment at the locations indicated.
- Drill 0.189" dia. holes 1" from the face of the mullion at the locations indicated.

See **Detail 2**.

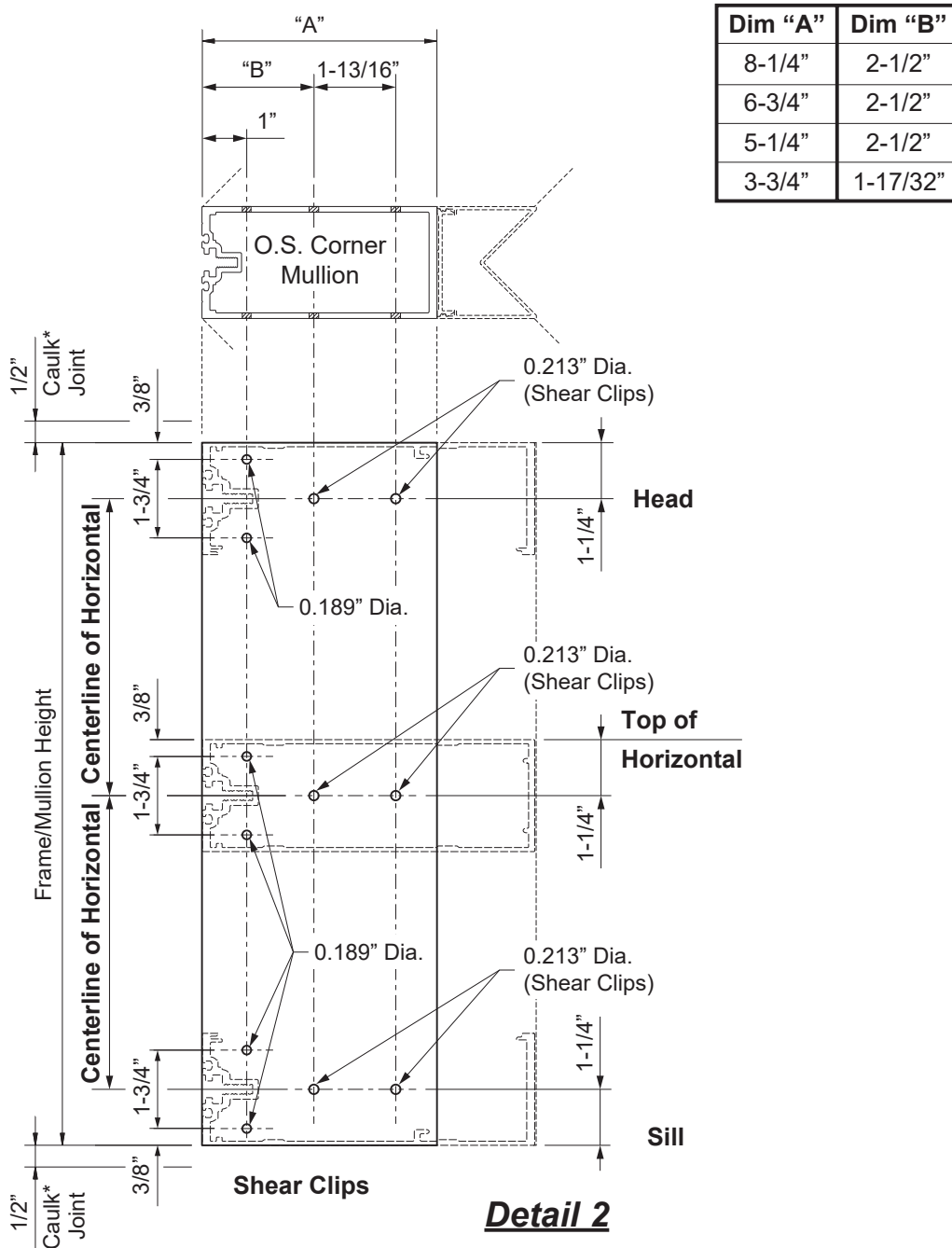

FRAME FABRICATION

STEP 2 USING ALTERNATE REINFORCING

Engineering calculations may require the mullions to be reinforced with either steel or aluminum.

- Reinforcing shall be attached to the mullion in accordance with engineering requirements
 - Slide the reinforcing into the mullion and into position.
 - When attaching reinforcing at shear block locations, drill a 0.281" diameter (#9/32 bit) hole in the mullion, being careful not to drill a hole in reinforcing.
 - Drill a 0.213" diameter (#3 bit) hole in the reinforcing through the previous holes.
 - Tap the 0.213" hole to accommodate a 1/4-20 fastener.
 - Attach the shear blocks to the mullion and steel with two PF-2528 fasteners per block.
- See **Detail 3**.

Note: Reinforcing to be determined by a qualified engineer.
Steel reinforcing must be coated to insulate the steel from the aluminum.

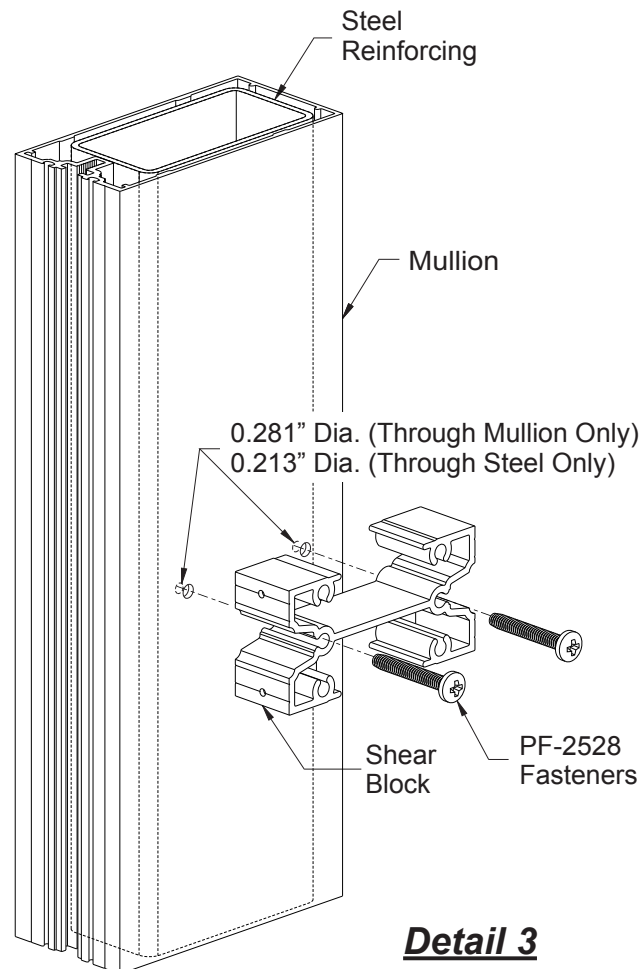

FRAME FABRICATION

STEP 3 ATTACH MULLION END CAPS

Mullion end caps are required at the head and sill of jamb and mullions.

- Clean the mullion ends and mullion end caps with a cleaner and method approved by the sealant manufacturer.
- Apply sealant to the spline cavity and along the front of the mullions on both ends prior to installing mullion end caps, FW-2500-SS.
- Attach the mullion end caps to each end of the mullion with FC-1410 fasteners as shown **Detail 4**.
- Tool the excess sealant flush between the mullion end cap and the mullion.
- Seal over all screw heads.
- At the bottom of the mullions, apply sealant to the center cavity to a height of 1/2".

See **Detail 5**.

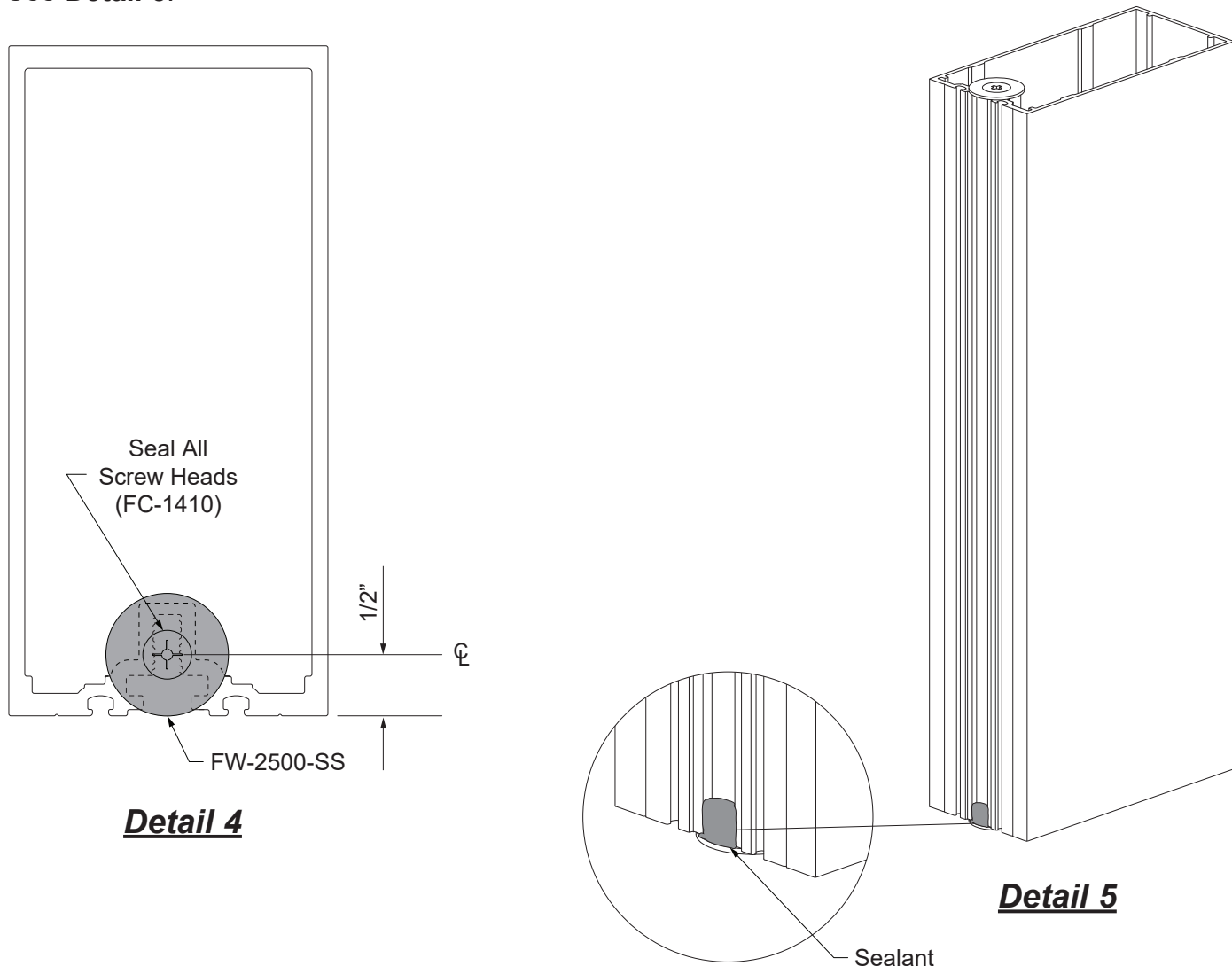

FRAME FABRICATION

STEP 4 ATTACH SHEAR BLOCKS FOR HORIZONTALS

Shear blocks are used to attach horizontal members to the jamb and mullions:

-Attach the shear blocks to jambs and mullions with two PF-2528 fasteners per block.

See **Detail 6**.

-Additional fasteners may be required to accommodate special project conditions.

Note: See **Step 2** on **Page 9** when using reinforcing.

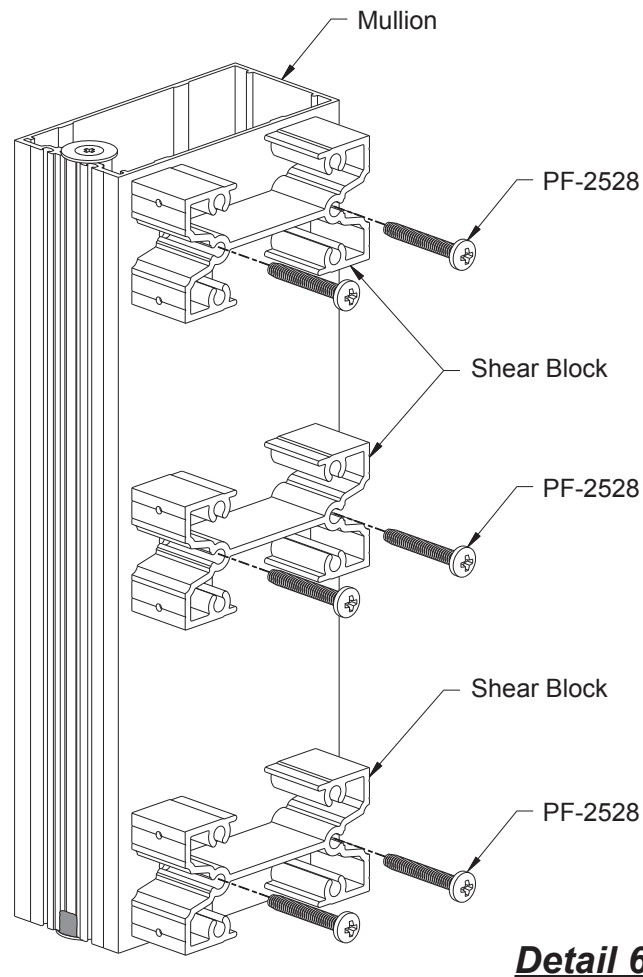

FRAME FABRICATION

STEP 5 FABRICATE HORIZONTAL MEMBERS

Horizontals with Concealed Fasteners:

- Layout hole locations on the face of the horizontal at both ends as shown below.
 - Drill 0.236" diameter (#B bit) holes and countersink for #12 flat head fasteners.
- See **Detail 7**.

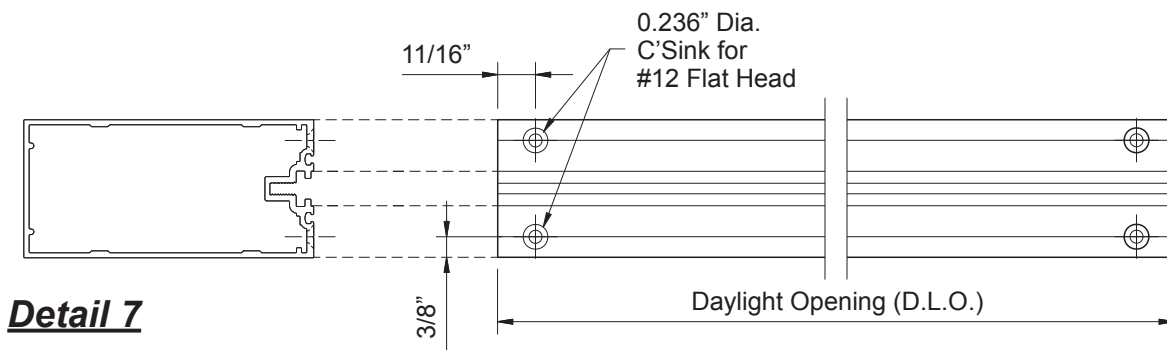

Head and Sill Horizontal Member Anchor Preps:

- Drill appropriate size clearance holes at each end of the mullion as shown in **Detail 8**, or according to shop drawings or engineering calculations to align with corresponding anchor holes in "T" and "F" anchors.

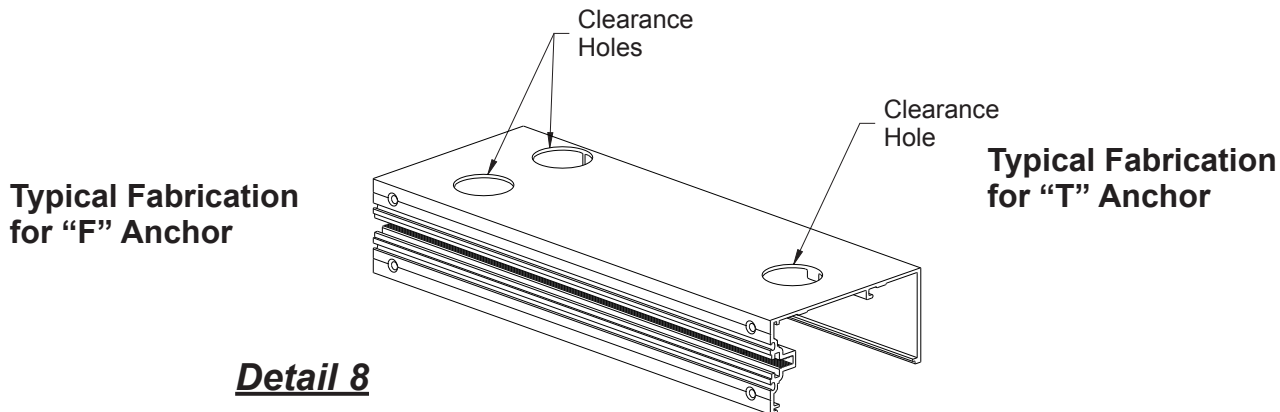

FRAME FABRICATION

STEP 6 FABRICATE PERIMETER TRIM

-Cut E9-3409 perimeter trim as shown in **Detail 9**.
-For elevations over 24' in length or height, perimeter trim must be spliced. Perimeter trim splice joint must be 1/2" and located no more than 18' between splice joints. Refer to **Detail 33** on **Page 29**.

-Notch perimeter trim 1-1/4" from each splice end as shown in **Detail 10**.

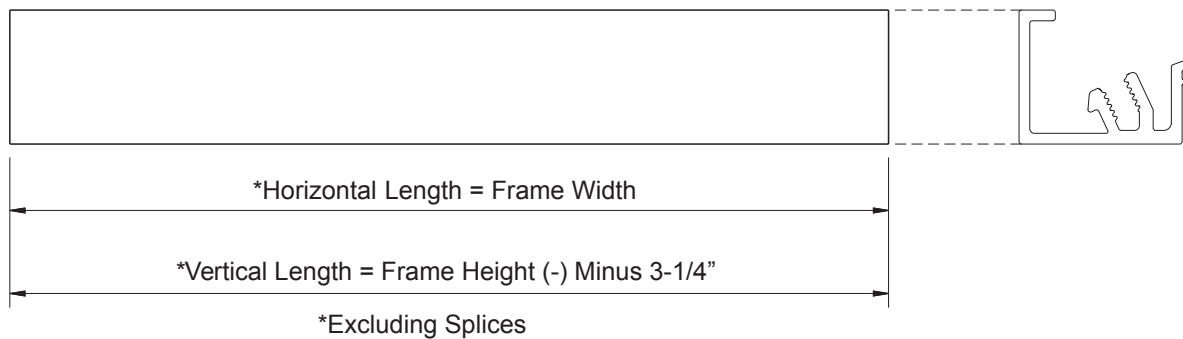

Detail 9

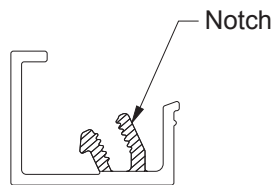

Detail 10

FRAME FABRICATION

**STEP 7
FABRICATE CORNER GLAZING ADAPTOR**

- Cut E9-3413 outside corner mullion adaptor to vertical mullion length.
- Drill 0.281" dia. (9/32 bit) clear holes every 9" on center.

See **Detail 11**.

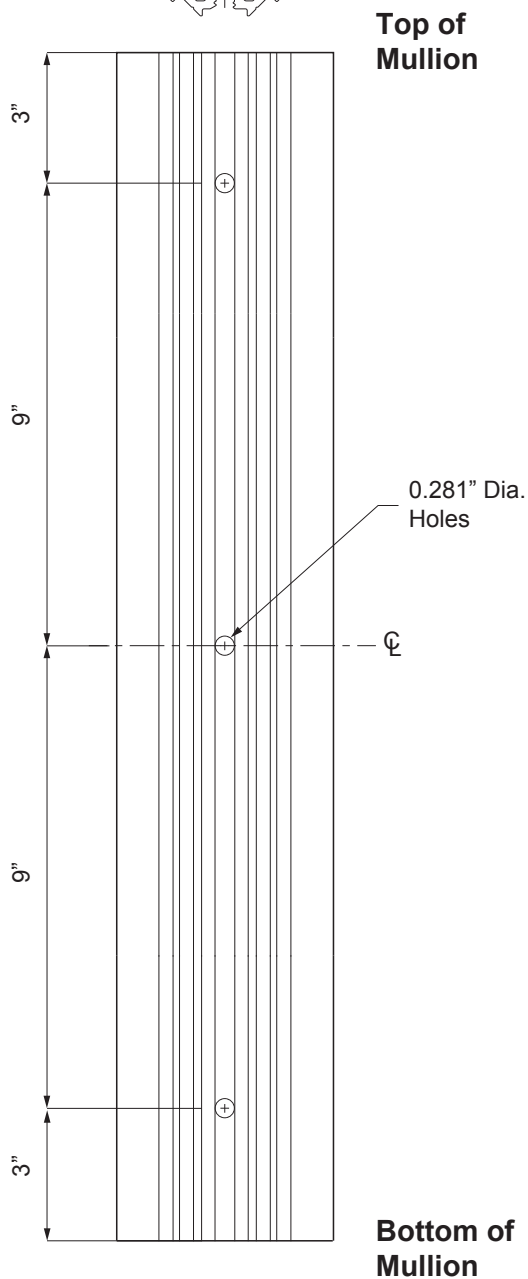
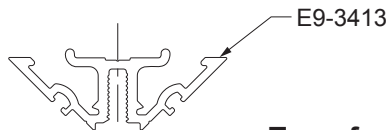

Detail 11

FRAME INSTALLATION

STEP 8 JAMB/MULLION INSTALLATION WITH MULLION END ANCHORS

- Insert mullion "T" and "F" end anchors into the top and bottom of the mullions before erecting them into the opening.
- Position the jamb and intermediate mullions and attach them to the structure.

See **Detail 12**.

Note: Shim under the mullions to transfer glazing dead loads to the building structure.

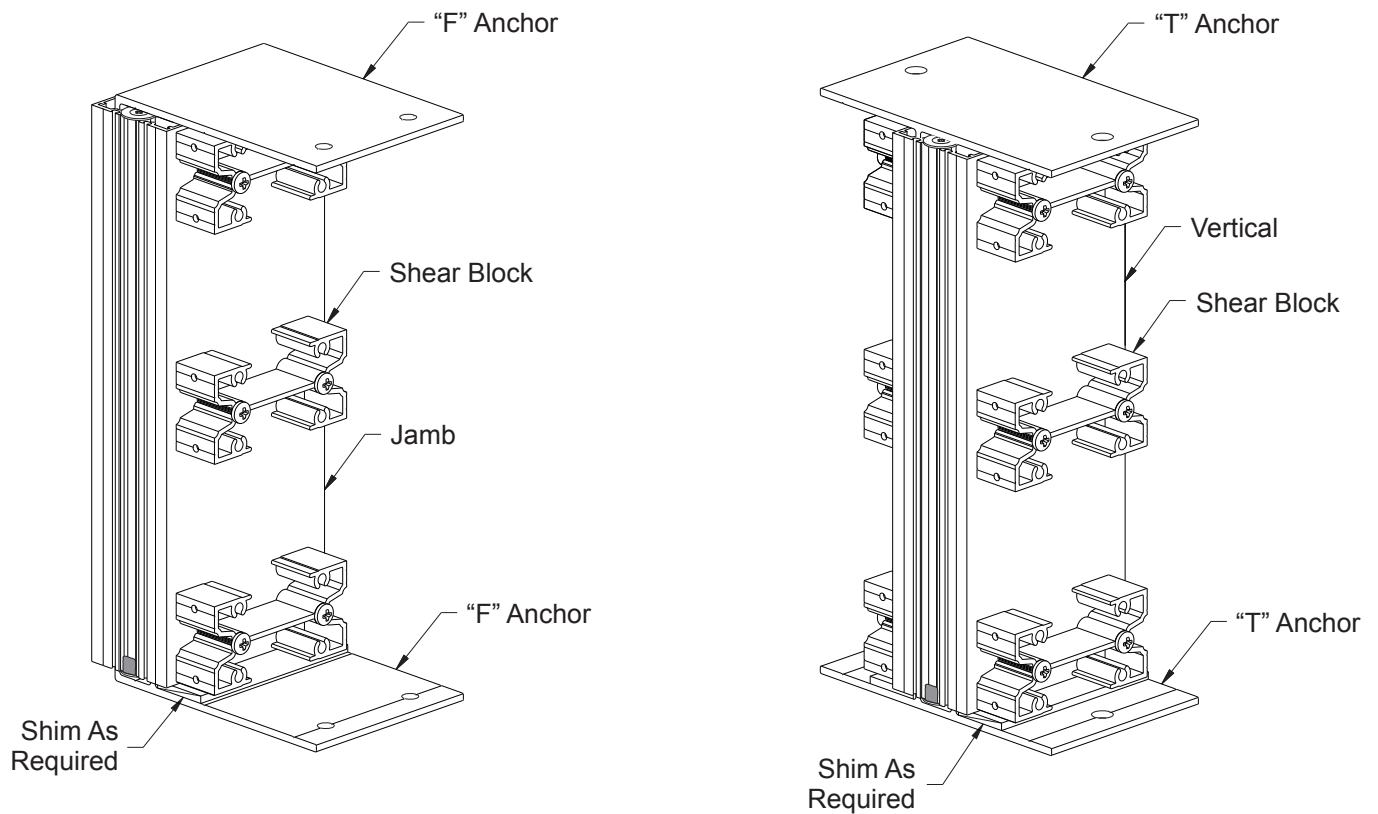

Detail 12

FRAME INSTALLATION

**STEP 8A
VERTICAL INSTALLATION
AT DOOR JAMB END ANCHORS**

The mullions at the door jambs are set directly upon the sill substrate without any shims and are sealed against the substrate. The anchors to be used at this location are specified by the approved shop drawings and or P.E. calculations.

-Locate the mullion anchor for the door jamb and install it to the substrate according to the approved shop drawings and P.E. calculations.

Note: if using an exposed fasteners shear block as a mullion anchor, check to ensure the sill shear block fasteners will not cause interference. Field modify the shear block anchor as required. See **Detail 14**.

-Clean all contact surfaces as recommended by sealant manufacturer.
-Set the mullion on the anchor, directly onto the sill substrate in a bed of sealant. Avoid using shims at this location. See **Detail 13**.

-Refer to the approved shop drawings for any additional fasteners required at anchor.
-Tool sealant at the bottom of the mullion at the sill substrate around the perimeter of the mullion. See **Detail 15**.

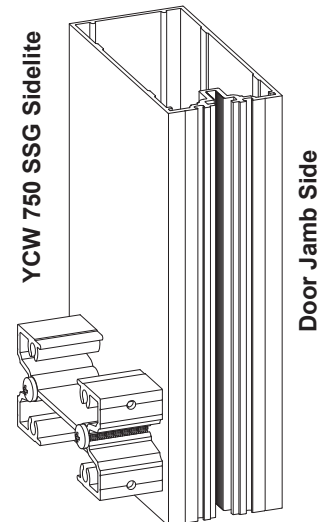

Detail 14

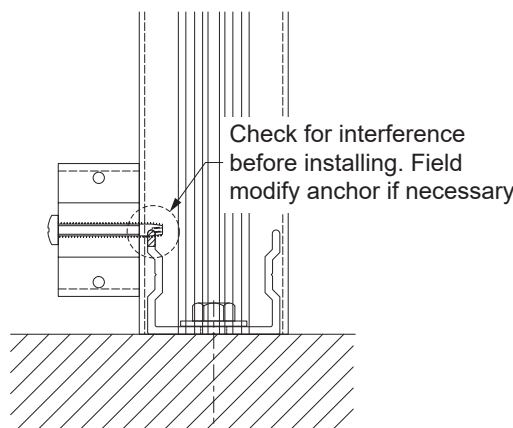
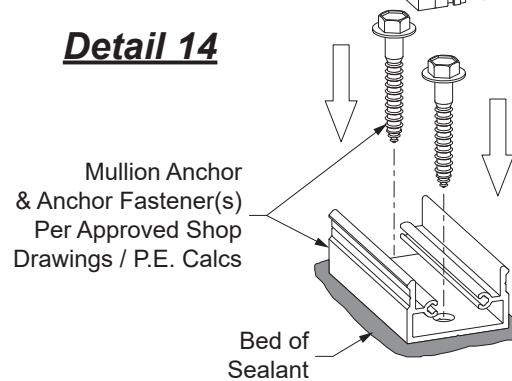

Detail 13

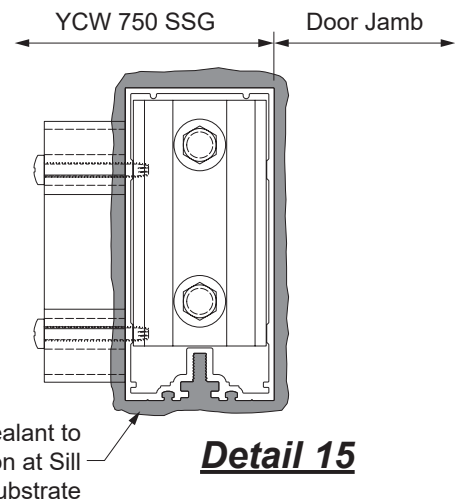

Detail 15

FRAME INSTALLATION

STEP 9 TYPICAL MULLION SPLICE

- Clean all surfaces as recommended by sealant manufacturer.
- Drill .236" splice sleeve attachment holes into the upper and lower mullion. Attachment hole locations should be drilled as shown in chart below from the front and back of mullion, and 1" and 8" down from the top of the lower mullion and 1" and 8" up from the bottom of the upper mullion.
- Lower the splice sleeve into top of lower mullion 9". Match drill .189" splice sleeve anchor holes into the splice sleeve and attach with (2) two FC-1212 fasteners, on both sides of the lower mullion.
- Slide the upper mullion down over the splice sleeve flush with the top of the lower mullion. Match drill .189" splice sleeve anchor holes into the splice sleeve and attach with (2) two FC-1212 fasteners, on both sides of the upper mullion.
- Apply and tool sealant to the face and sides of the splice sleeve. See Note on **Page iii**.

See **Detail 16**.

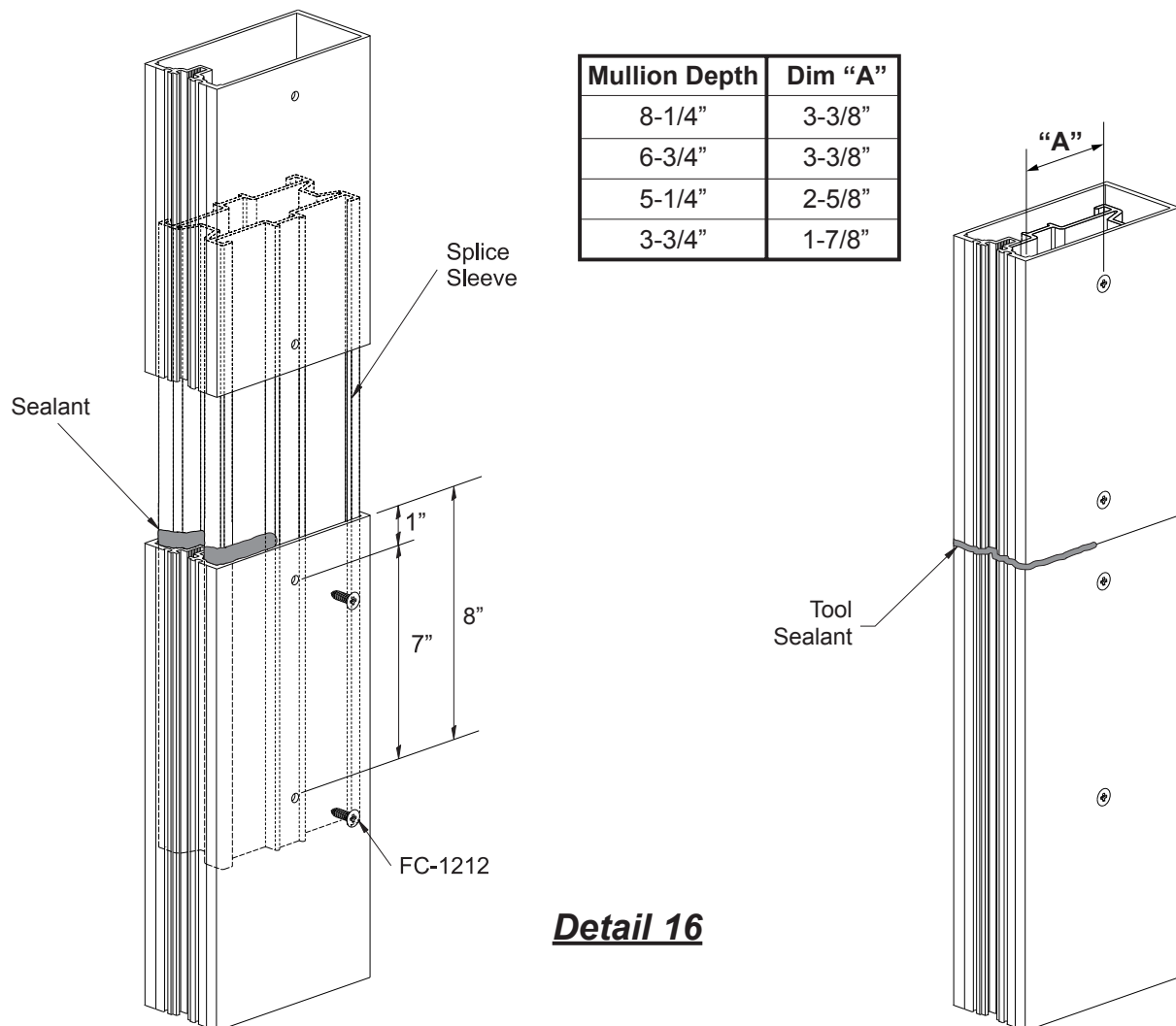

FRAME INSTALLATION

**STEP 10
INSTALL WIND LOAD / DEAD LOAD ANCHORS**

-Install steel wind load and dead load anchor clips. Anchor clips are normally template or line set before mullions are installed . When using standard YKK AP anchors, typical space between the back of the mullion and the anchoring substrate to be 1" nominal.

See **Detail 17**.

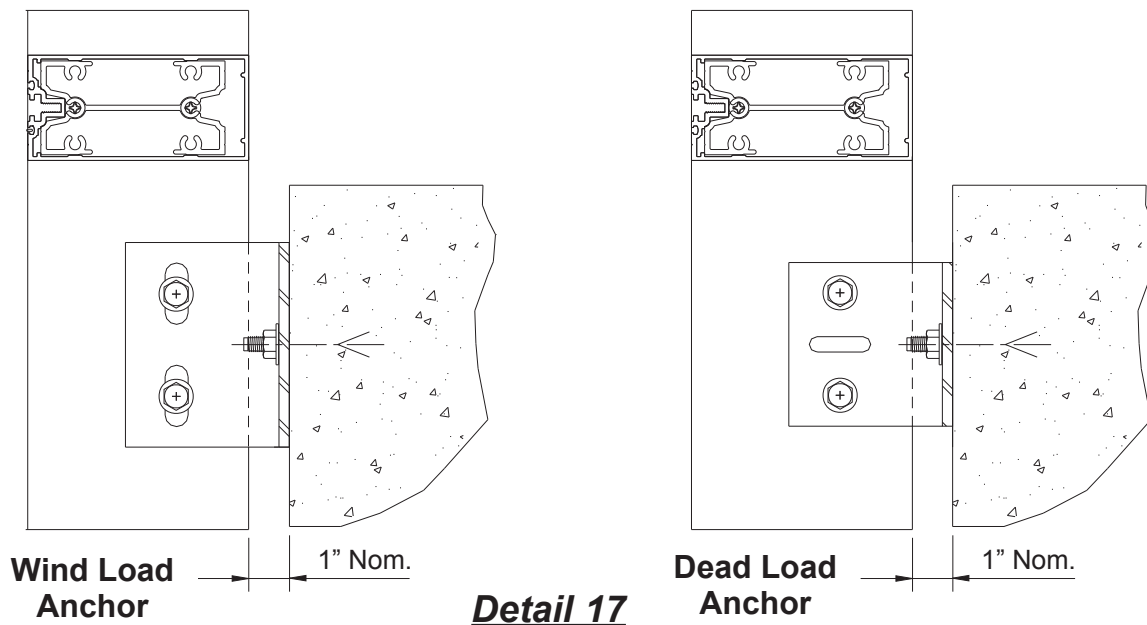

Detail 17

-After positioning mullions, drill and install appropriate diameter anchor bolts.

All anchors and bolts must be checked by a qualified engineer.

-Nylon slip pads, E3-0103, must be installed between mullion and anchor.

See **Detail 18**.

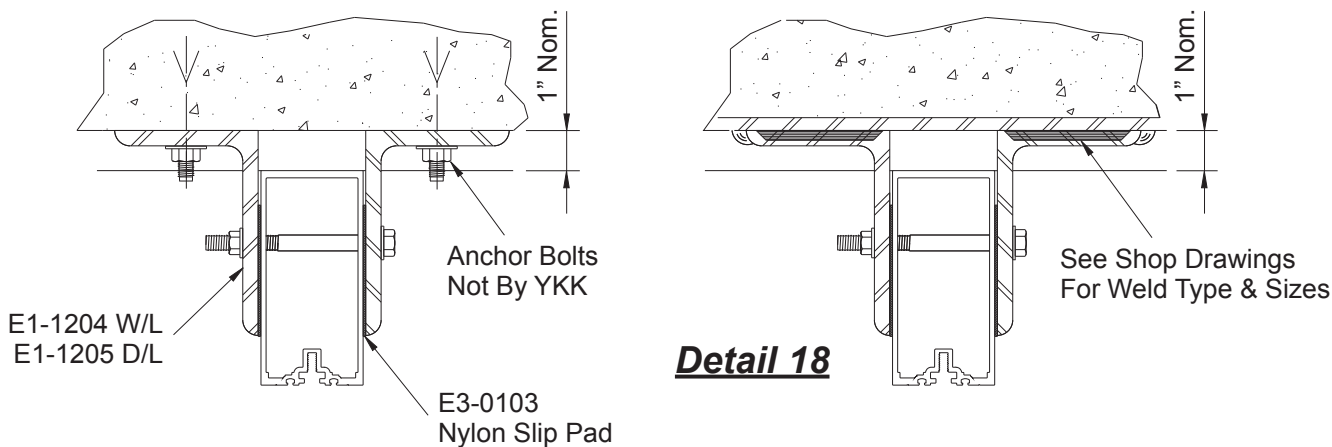

Detail 18

FRAME INSTALLATION

TYPICAL WIND LOAD ANCHOR

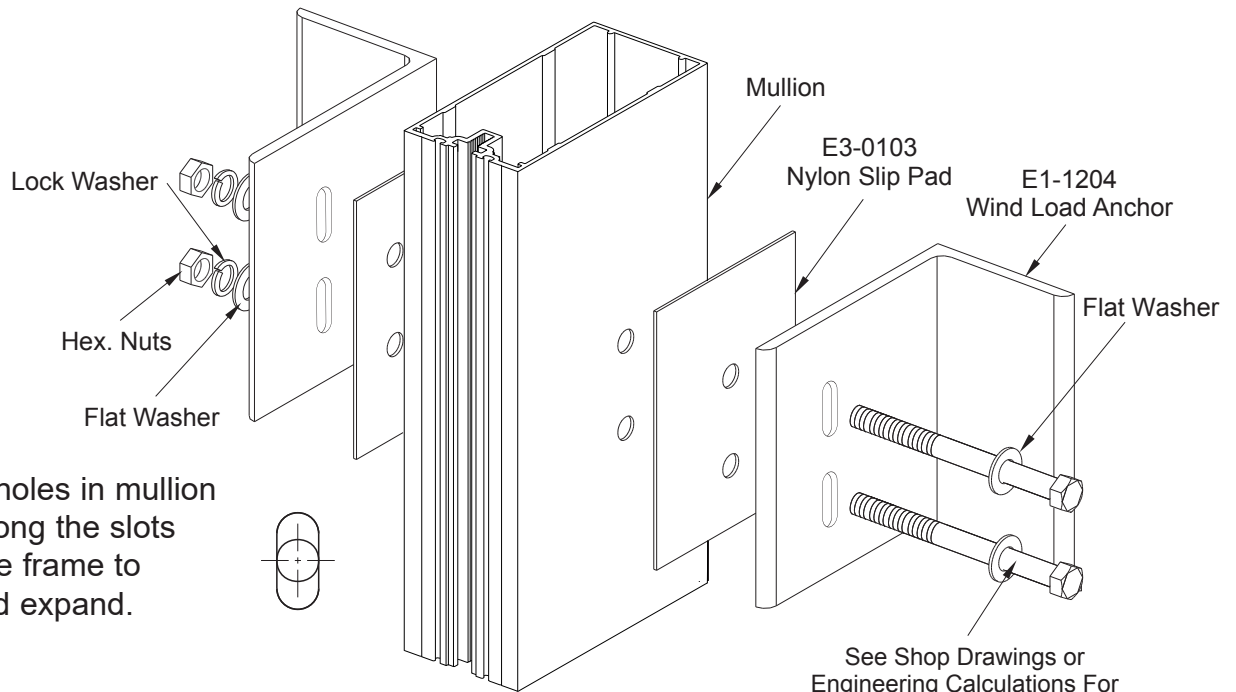

Note: Drill holes in mullion centered along the slots to permit the frame to contract and expand.

See Shop Drawings or Engineering Calculations For Correct Anchor and Bolt Size (Bolts Not By YKK)

Detail 19

TYPICAL DEAD LOAD ANCHOR

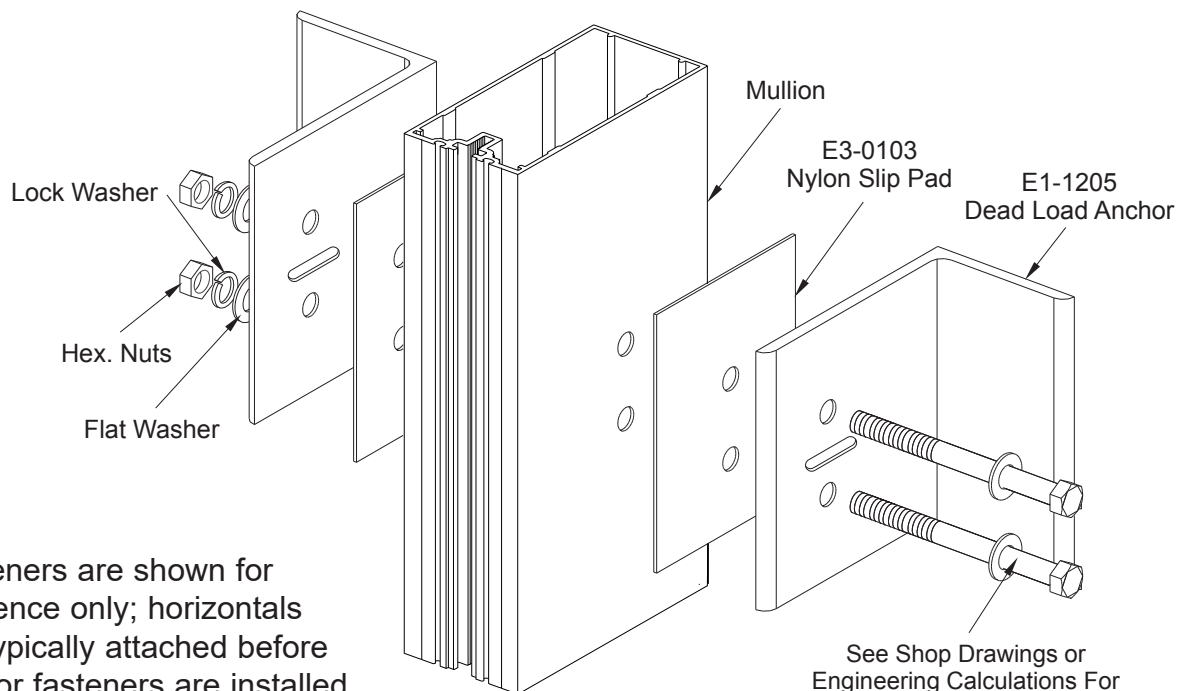

Note: Fasteners are shown for reference only; horizontals are typically attached before anchor fasteners are installed.

See Shop Drawings or Engineering Calculations For Correct Anchor and Bolt Size (Bolts Not By YKK)

FRAME INSTALLATION

JAMB WIND LOAD ANCHOR

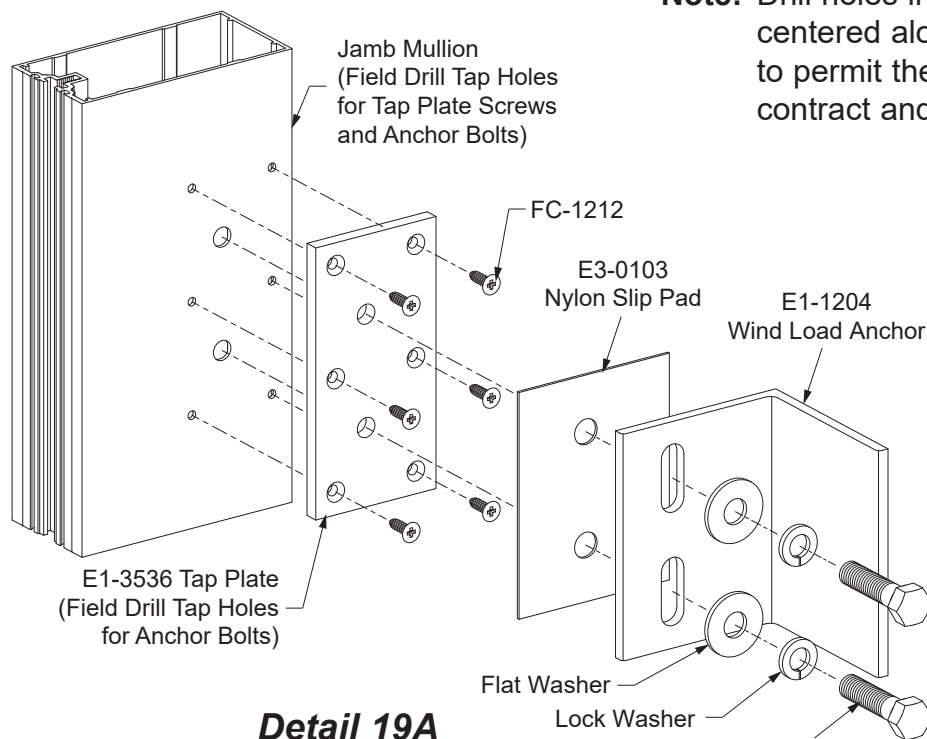

Note: Drill holes in mullion centered along the slots to permit the frame to contract and expand.

Detail 19A

JAMB DEAD LOAD ANCHOR

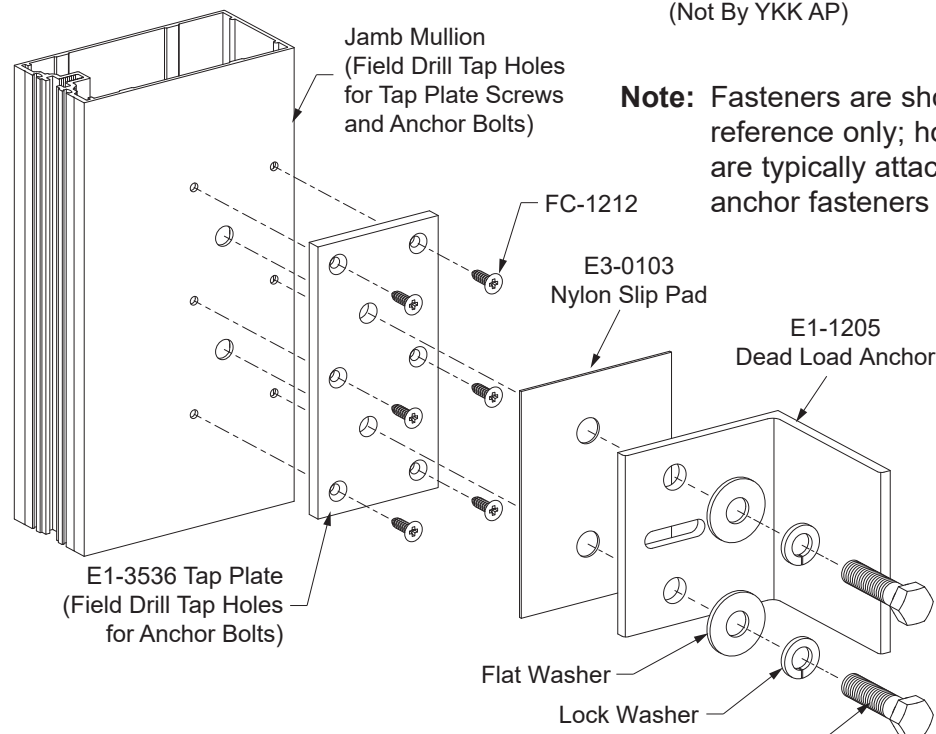

See Shop Drawings or
Engineering Calculations
For Correct Bolt Size
(Not By YKK AP)

Note: Fasteners are shown for reference only; horizontals are typically attached before anchor fasteners are installed.

See Shop Drawings or
Engineering Calculations
For Correct Bolt Size
(Not By YKK AP)

FRAME INSTALLATION

STEP 11 ATTACH HORIZONTAL MEMBERS

Note: Before applying any sealant, clean aluminum surfaces using cleaner and method approved by sealant manufacturer.

- Just prior to attaching the horizontal members to the mullion, apply sealant to the front of the shear block as shown.
 - Slide the horizontal members towards the mullion and attach them to the shear blocks at each end with two FC-1212 fasteners.
 - Tool and wipe away any excess sealant at the mullion to horizontal joints.
 - Seal horizontal to shear block fastener heads.
- See **Detail 20**.

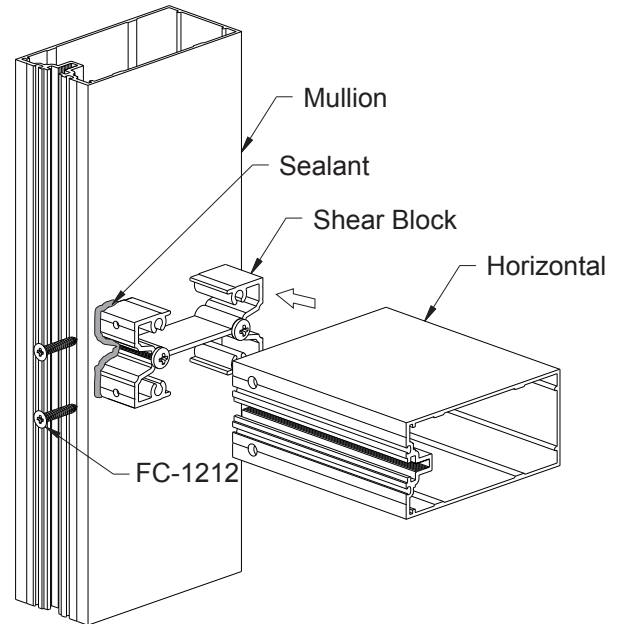

Detail 20

For Two Piece Horizontals:

Note: Before applying any sealant, clean aluminum surfaces using cleaner and method approved by sealant manufacturer.

- Just prior to attaching the horizontal members to the mullion, apply sealant to the front of the shear block as shown.
- Rotate the horizontal down over the shear clip. Make sure the horizontal and mullion glazing pockets are flush.
- Attach the horizontals to the shear blocks with two FC-1212 fasteners.
- Snap on the horizontal flush filler.
- Seal horizontal to shear block fastener heads.

See **Detail 21**.

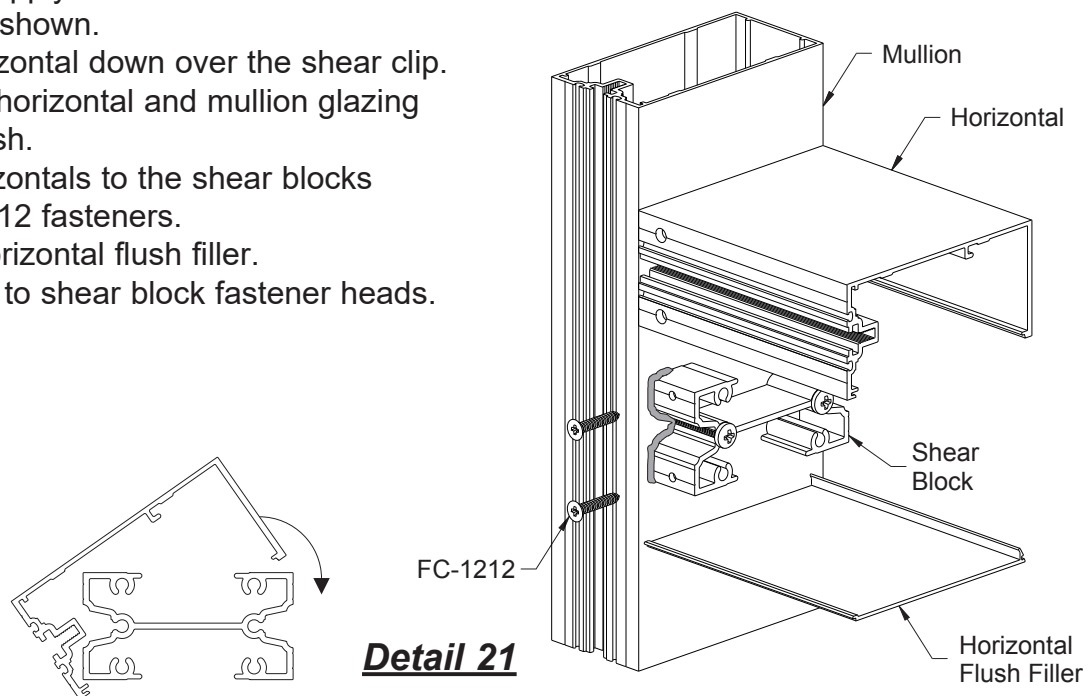

Detail 21

FRAME INSTALLATION**STEP 11 (Continued)****ATTACH HEAD AND SILL MEMBERS**

Note: Before applying any sealant, clean aluminum surfaces using cleaner and method approved by sealant manufacturer.

-Just prior to attaching the horizontal members to the mullion, apply sealant to the front of the shear block as shown.

-Seal head/sill to shear block fastener heads.

See **Detail 22**.

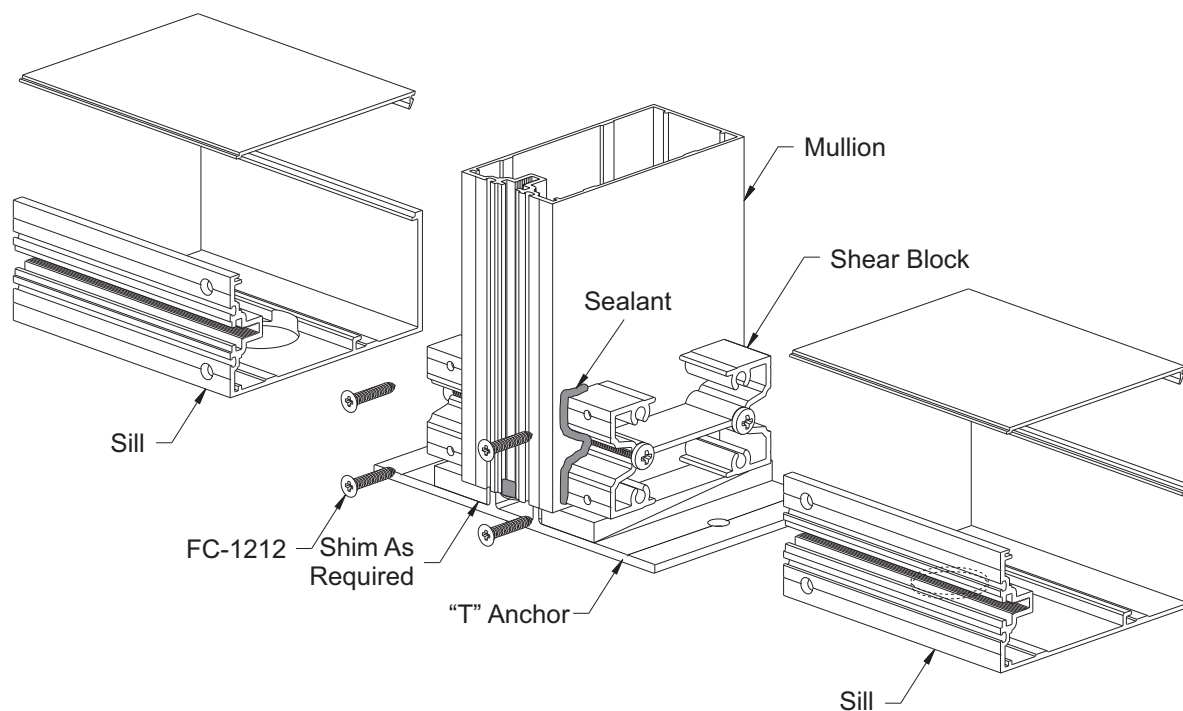

Detail 22

STEP 11 (Continued) ATTACH HEAD AND SILL MEMBERS

Open Back Head & Sill Members at End Bays:

- To clear the mullions at end bays shear blocks must be pre-attached to the head and sill members through the face of the mullion with FC-1212 fasteners.
- Just prior to attaching the horizontal members to the mullion, apply sealant to the front of the horizontal and shear block as shown.
- Position the head/sill members into place and attach the shear blocks to the mullions with two PF-2528 fasteners per shear block.
- Provide anchor fasteners per approved shop drawings or engineering calculations.
- Install the anchor fasteners as recommended by fastener manufacturer.
- Snap on the mullion flush filler.
- Seal head/sill to shear block fastener heads.

See **Detail 23**.

Caution: A solid shim must be placed under the mullion to transfer glazing dead loads to the foundation.

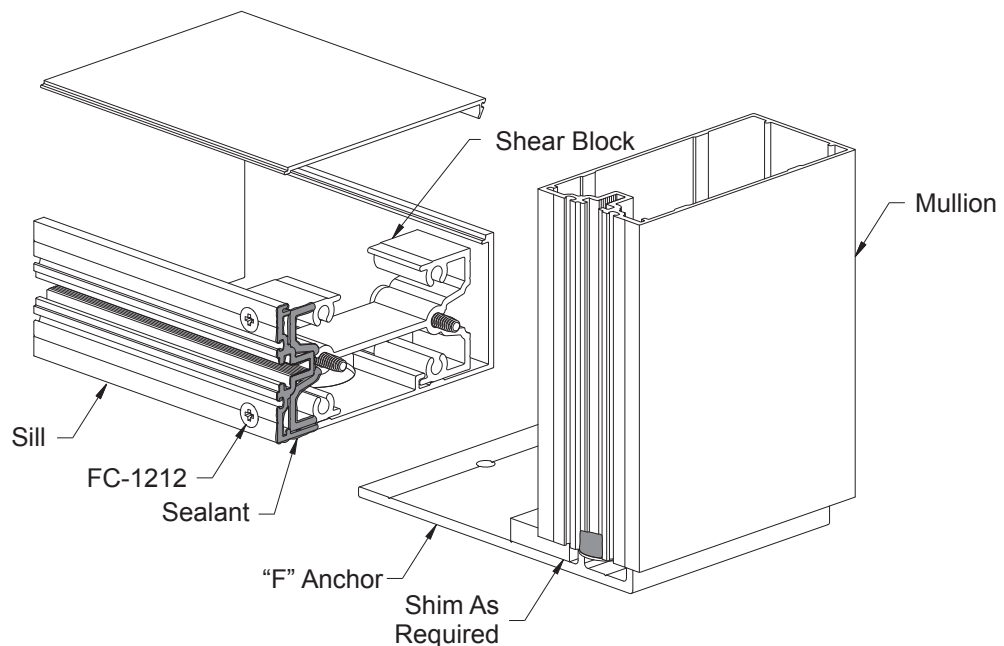

Detail 23

FRAME INSTALLATION

**STEP 12
APPLY PERIMETER SEALANT**

- Clean the area around the perimeter of the frame with cleaner and method approved by sealant manufacturer. **Note:** Taping the front face of the mullion is recommended to keep the surface free of sealant.
- Place backer rod between the perimeter of the frame and the substrate.
- Apply and tool sealant to the substrate and the curtain wall frame.

See **Detail 24**.

Note: Additional space at the caulk joint may be required to allow for expansion and/or contraction of the system per a qualified engineer's review, (1/2" typical, 1/4" minimum).

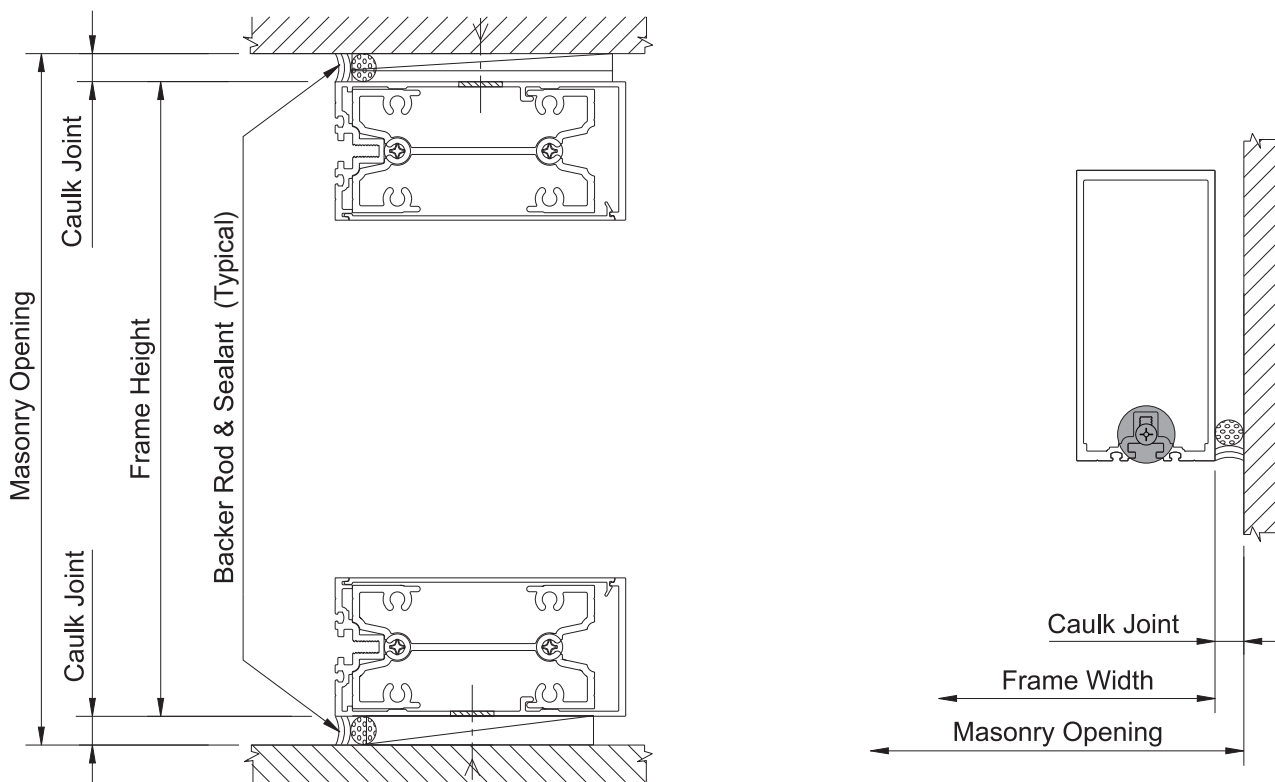

Detail 24

GLAZING

STEP 13 INSTALL GLAZING ADAPTORS (When Required for 1/4" Glazing)

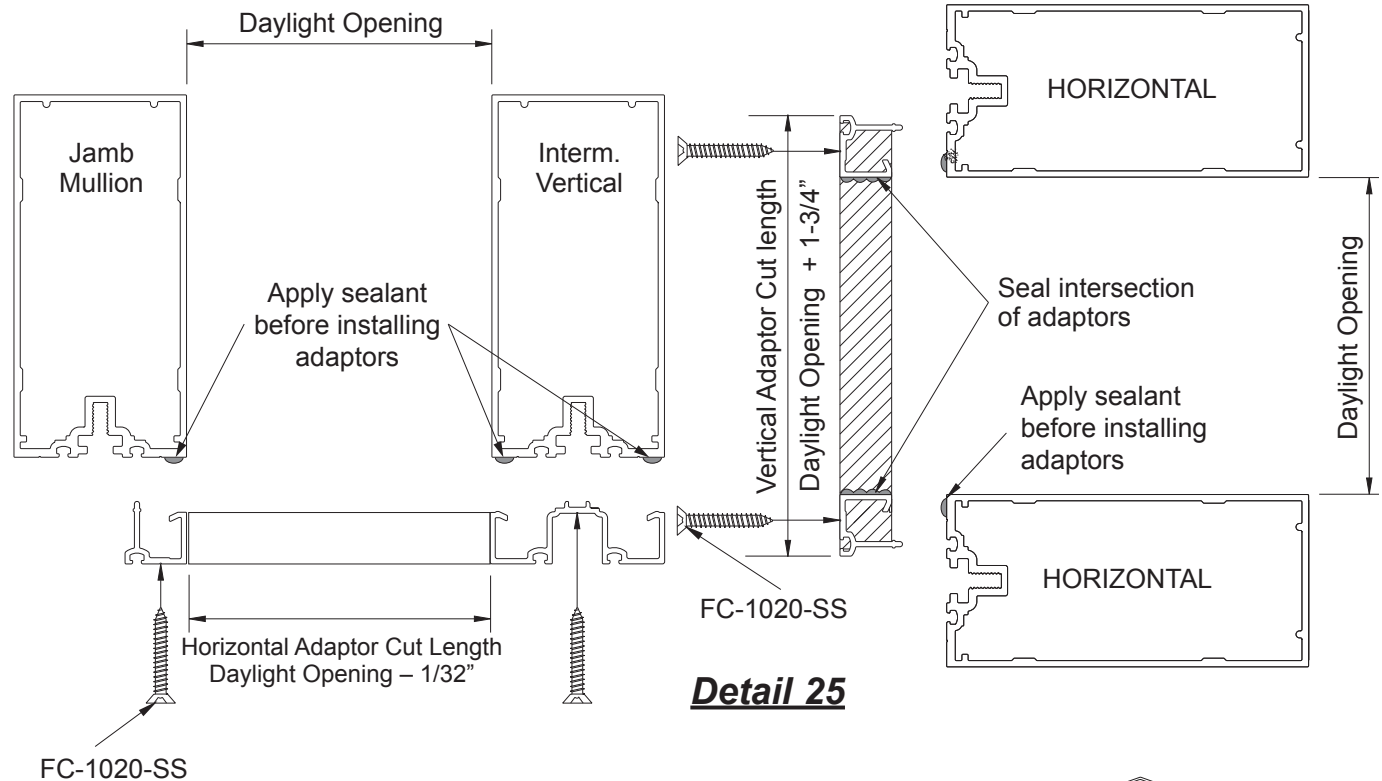

Detail 25

- Cut glazing adaptors to size:
 Vertical Cut Length = Daylight Opening plus(+) 1-3/4".
 Horizontal Cut Length = Daylight Opening minus(-) 1/32".
 - Drill and countersink each adaptor with 0.189" dia. (#12) holes 2" from each end and 24" O.C., or as directed by P.E. calculations.
 - Dry fit adaptors and match drill 0.141" diameter (#3) holes on mullion to receive FC-1020-SS screws.
 - Clean the area around the mullion glazing reglet and the glazing adaptor with a cleaner approved by the sealant manufacturer.
 - Apply sealant to the front face of the mullion as shown, and the ends of the horizontal adaptors.
 - Install the adaptors with FC-1020-SS screws. Install the horizontal adaptors first centered along the daylight opening.
 - Tool sealant at all adaptor intersections and seal all screw heads.
- See **Detail 25** and **Detail 26**.

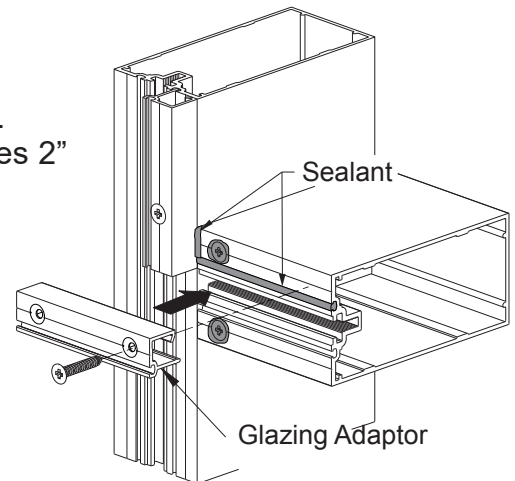

Detail 26

GLAZING

STEP 14 INSTALL INTERIOR GLAZING SPACERS

- Cut vertical glazing spacers to Daylight Opening plus (+) 1-3/4". If no glazing adaptors are used, vertical glazing spacers may run continuous to the length of the vertical mullion
- Cut horizontal glazing spacers to Daylight Opening + 1".
- Install vertical glazing spacers first, centered along the daylight opening.
- Notch dart off 1/2" on both ends of horizontal gasket as shown in **Detail 27**.
- Install horizontal glazing spacers by pushing each end into the reglet. Next press the center of glazing spacer into the reglet and then push the rest of the spacer into the reglet working from the center towards each end.

See **Detail 27**.

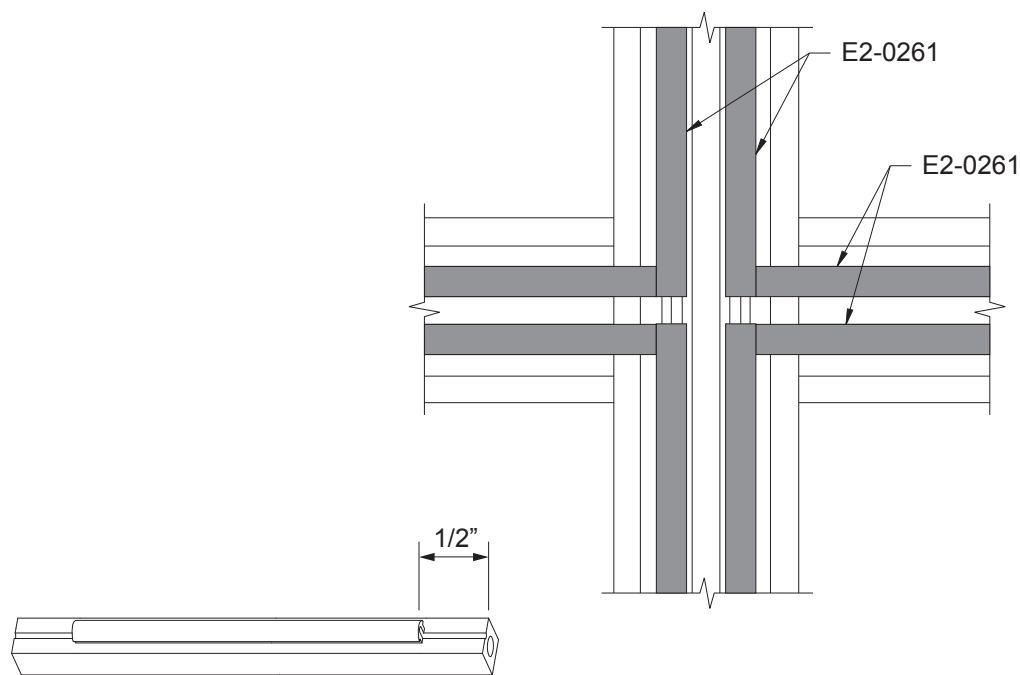

Detail 27

Glazing

STEP 15 ATTACH PERIMETER TRIM

Sill and Jamb Perimeter Trim

Note: E1-3579 end cap must be attached at each end of the E9-3409 head, jamb and sill perimeter trim.

- Clean all joint surfaces using cleaner approved by sealant manufacturer.
- Apply sealant to the E9-3409 perimeter trim as shown in **Detail 28**.
- Fasten the E1-3579 end cap to the E9-3409 perimeter trim with one PC-1210 screw.
- Clean and remove excess sealant.

See **Detail 28**.

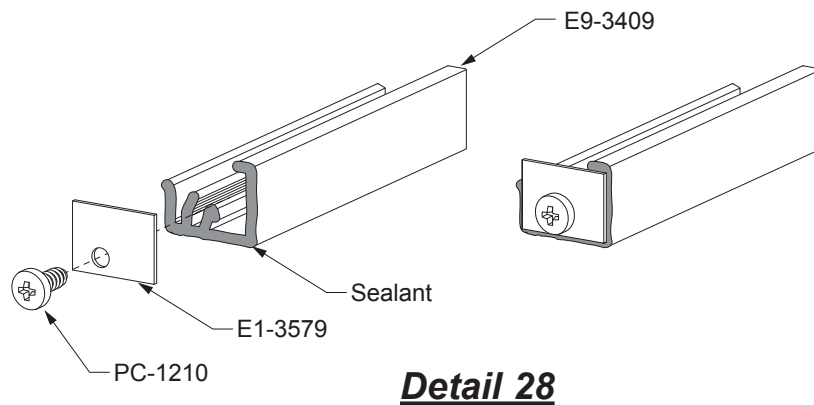

Glazing

**STEP 15 (Continued)
ATTACH PERIMETER TRIM**

Sill Perimeter Trim

-Apply E2-0110 spacer tape to the entire length of the E9-3409 perimeter trim member.
 -Attach E1-3543 perimeter trim clip to the E9-3409 perimeter trim member 1-1/4" from each end and at all intermediate vertical locations. Trim clip locations can be adjusted after perimeter trim is adhered to the sill member
 See **Detail 29**.

-Pull back the tapes liner of the perimeter trim 2" from each end to expose the adhesive backing.
 -Press the perimeter trim firmly onto the sill member.
 -Pull the remaining tape liner from the tape of the perimeter trim while continuing to press the perimeter trim firmly against the sill member.
 See **Detail 30** and **Detail 31**.

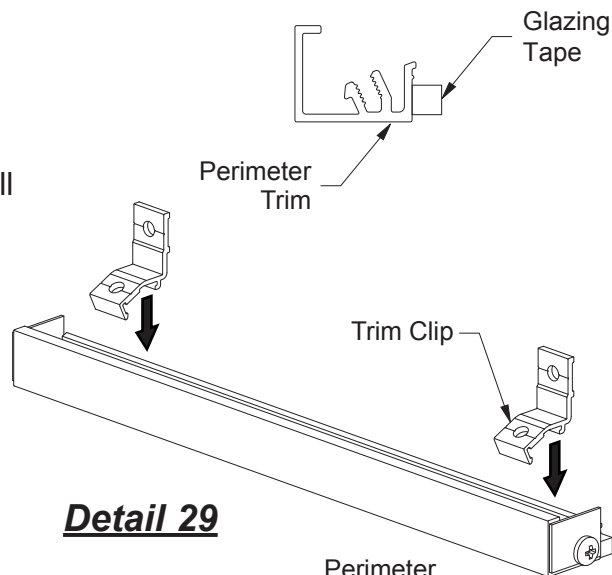

Detail 29

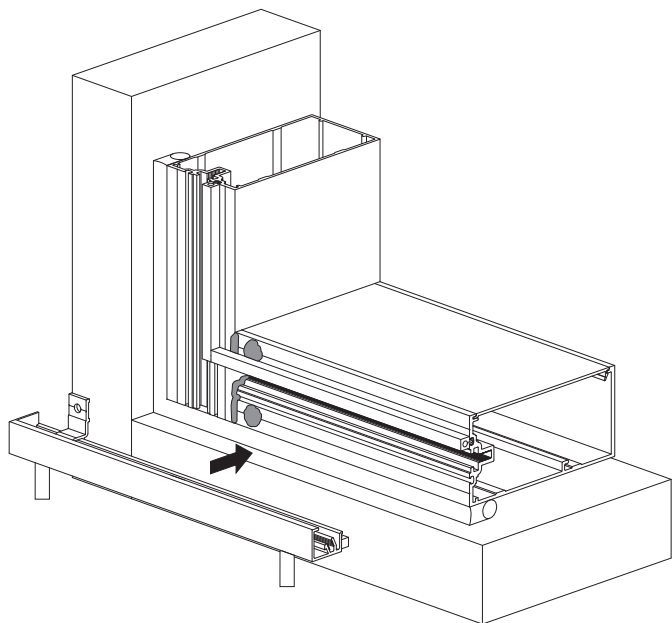
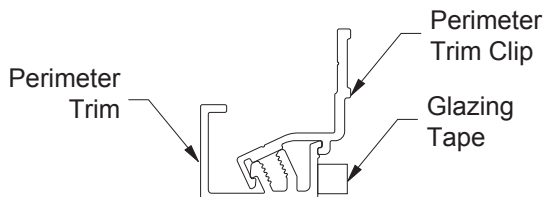

Detail 31

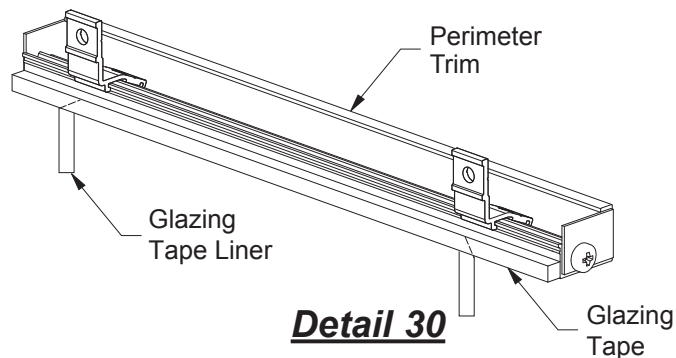

Detail 30

Glazing

STEP 15 (Continued) ATTACH PERIMETER TRIM

Sill and Head Perimeter Trim

- Using PM-2512-SS fasteners, fasten the perimeter trim clips into the spline of the mullions.
- Using PM-1006-SS fasteners, fasten the perimeter trim clip into the spline of the perimeter trim.

See **Detail 32**.

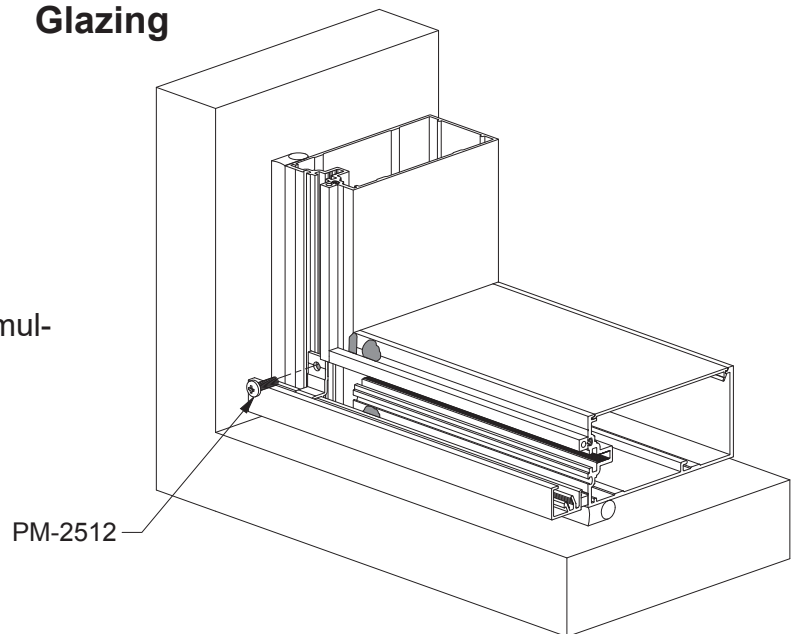

Detail 32

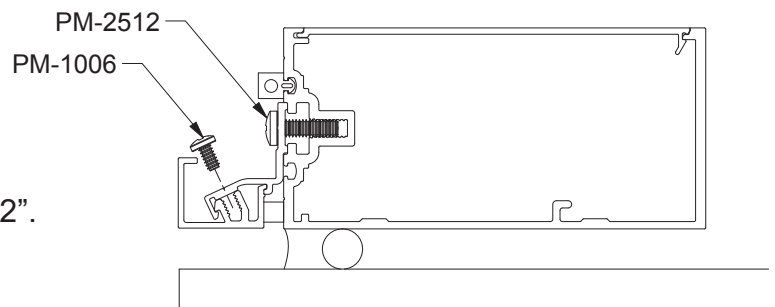

Sill Perimeter Trim Splice

- Cut E2-0070 silicone splice sleeve to 3" x 2".
- Clean perimeter trim and silicone splice sleeve per sealant manufacturer's recommendations at the splice location.
- Seal the perimeter trim at the splice location as shown in **Detail 33**, before positioning the flashing. Fit the silicone splice sleeve into the perimeter trim.
- Tool excess sealant.

See **Detail 33**.

Detail 33

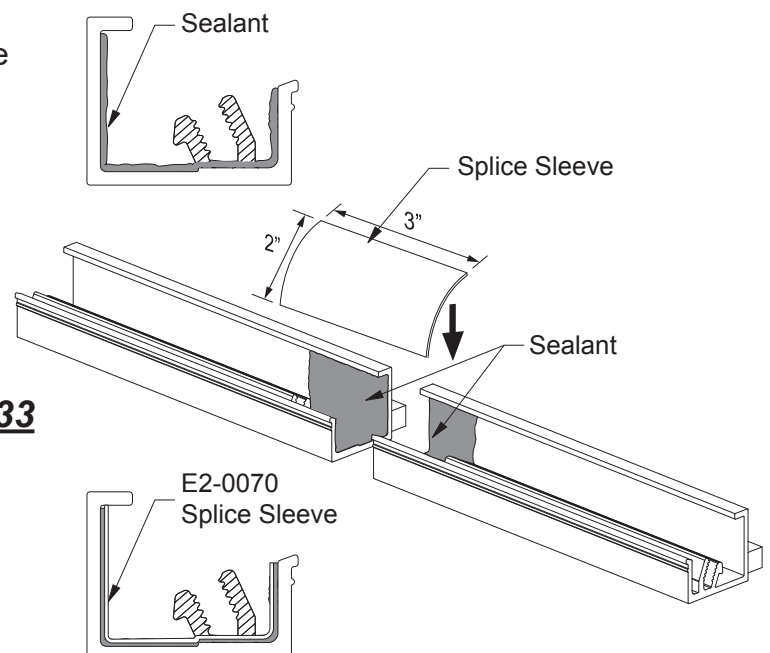

Glazing

**STEP 15 (Continued)
ATTACH PERIMETER TRIM**

Jamb Perimeter Trim

- Prepare the perimeter trim at jamb locations as stated on **Page 28**.
- Trim clips should be located 2" from each end of the perimeter trim, and 3' on center.
- Using PM-2512-SS fasteners, fasten the perimeter trim clips into the spline of the jamb member.
- Using PM-1006-SS fasteners, fasten the perimeter trim clip into the spline of the perimeter trim.

See **Detail 34**.

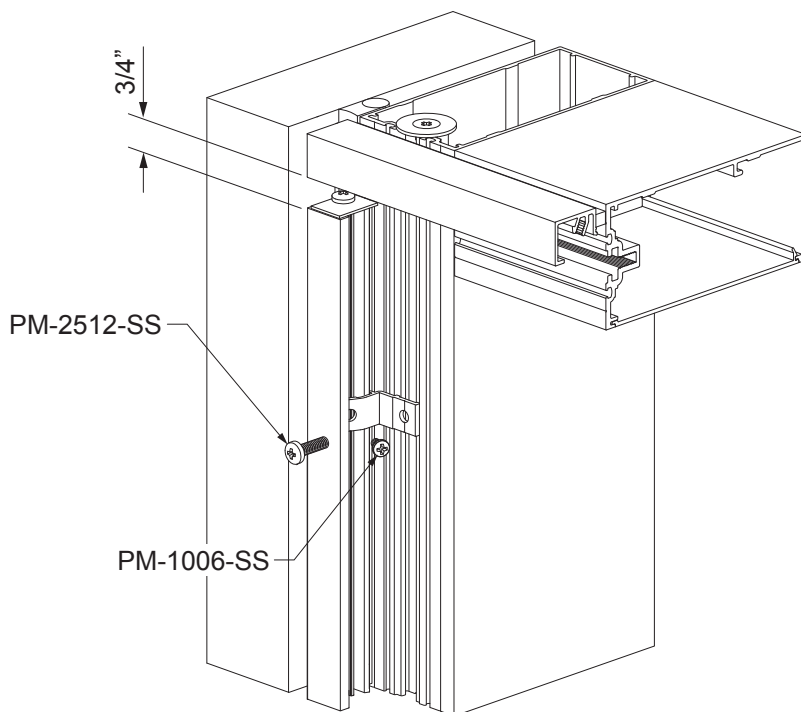

Detail 34

Head Condition Shown, Sill Condition Similar

Glazing

STEP 15A INSTALL PERIMETER TRIM AT DOOR JAMB

- Cut the vertical perimeter trim to Door Opening Height minus 3/4" and minus the Caulk Joint at the sill.
- Apply sealant to the ends of the vertical trim, and attach E1-3579 end caps at each end with PC-1210 fasteners, shown similarly on **Detail 28** on **Page 27**.
- Cut E2-0110 spacer tape to the length of the perimeter trim, and apply it to the perimeter trim as previously stated in **Page 28**.
- Attach perimeter trim clips to the perimeter trim at 2" from each end and at 3' maximum on center, shown similarly on **Detail 34** on **Page 30**.
- Using PM-2512-SS fasteners, fasten the perimeter trim clips into the spline of the mullion.
- Using PM-1006-SS fasteners, fasten the perimeter trim clip into the spline of the perimeter trim. Allow the same space above the sill substrate as the caulk joint at the sill.

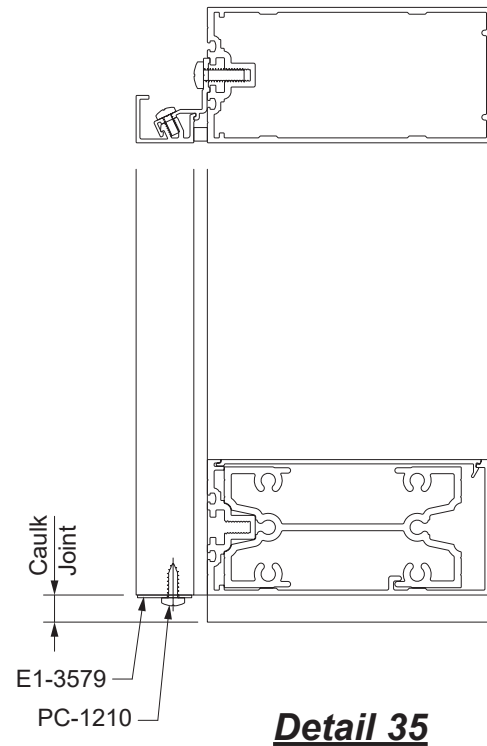

See **Detail 35**.

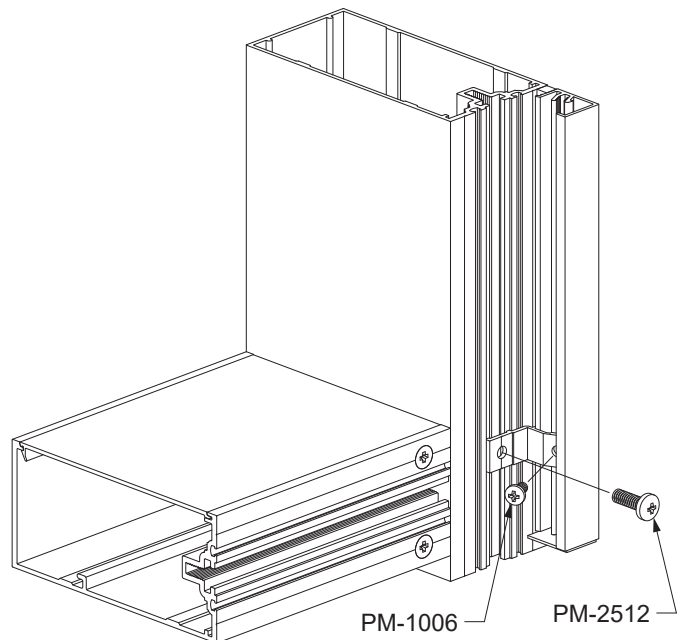

Glazing

**STEP 15A (Continued)
INSTALL PERIMETER TRIM AT DOOR JAMB**

Perimeter trim at the sill member is to be cut to overlap the mullion at the door jamb by 7/8". This perimeter trim is also to be notched at the end by 1-1/4" as previously shown on **Page 13**.

-Cut E2-0110 spacer tape to the length of the perimeter trim, and apply it to the perimeter trim as previously stated in **Page 28**.

-Using PM-2512-SS fasteners, fasten the perimeter trim clips into the spline of the sill.
-Using PM-1006-SS fasteners, fasten the perimeter trim clip into the spline of the perimeter trim.

See **Detail 36**.

-Cut a 2-1/4" x 2" piece of E2-0070 silicone sheet, and adhere it with sealant to span the gap between the sill perimeter trim and the trim at the door jamb.

-Apply sealant to the front of the sheet and the cavity behind the sheet.

See **Detail 37**.

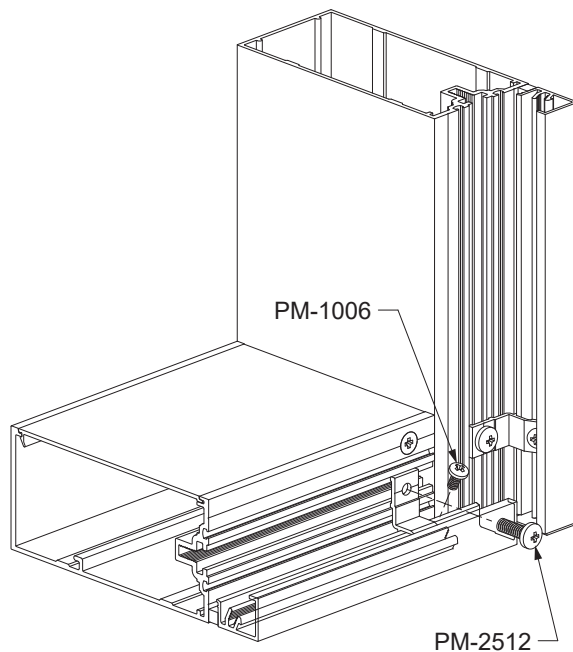

Detail 36

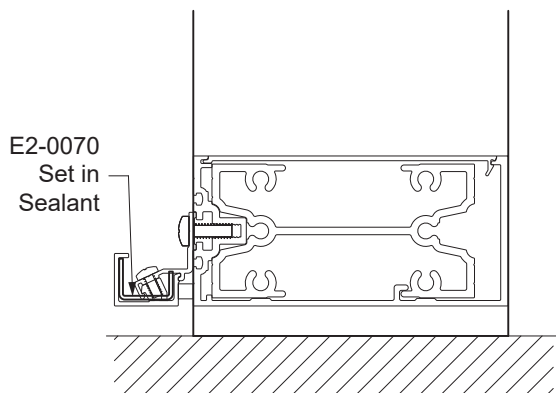

Detail 37

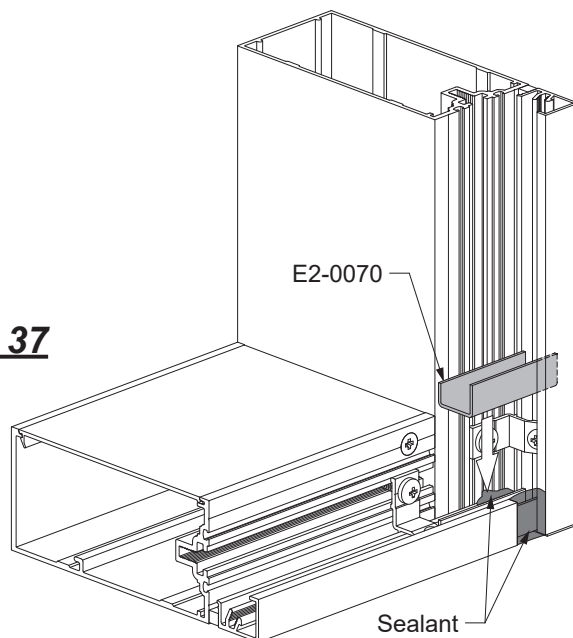

Glazing

STEP 16 (Continued) INSTALL DOOR SUBFRAMES

Refer to the **Entrances Installation Manual** for assembly of the door subframes. These subframes are typically installed onto the curtain wall framing at the jambs, and set directly upon the sill substrate. The subframe members are determined by the approved shop drawings.

-Clean all sealant contact surfaces as recommended by the sealant manufacturer.

-Install the jamb subframe onto the mullion with fasteners according to the approved shop drawings and/or P.E. calculations, setting the subframe jambs in beds of sealant as shown in **Detail 38**.

-Apply and tool sealant to the bottom of the jamb subframe as shown in **Detail 39**.

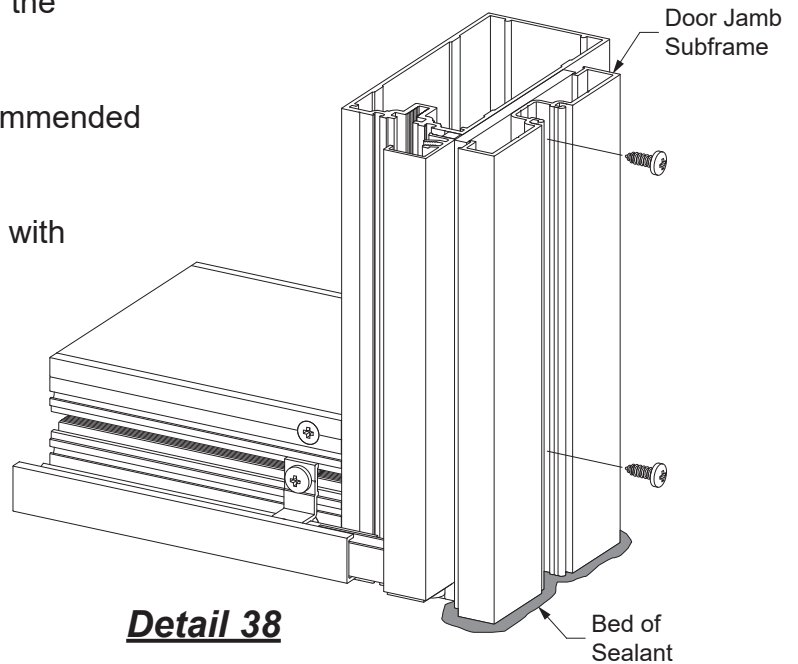

Detail 38

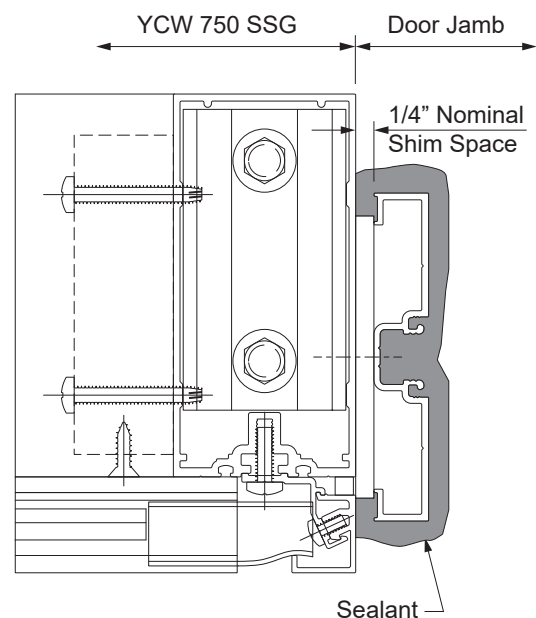

Detail 39

Glazing

**STEP 17
INSTALL SETTING BLOCK CHAIRS AND
SETTING BLOCKS**

Note:

Setting block chairs and setting blocks to be located at 1/4 points, or in accordance with glass manufacturers requirements.

-Install the setting block chair, E1-3545.
See **Detail 40**.

-Adhere the setting block E2-0224 to the top side of the setting block chair by removing tape backing.

See **Detail 41**.

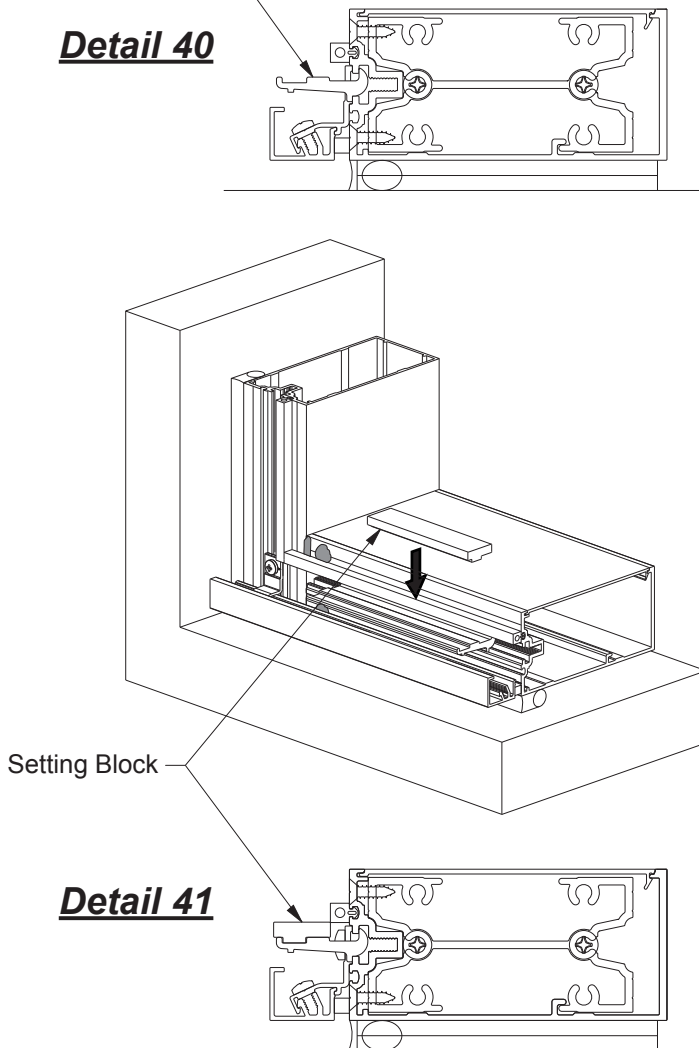
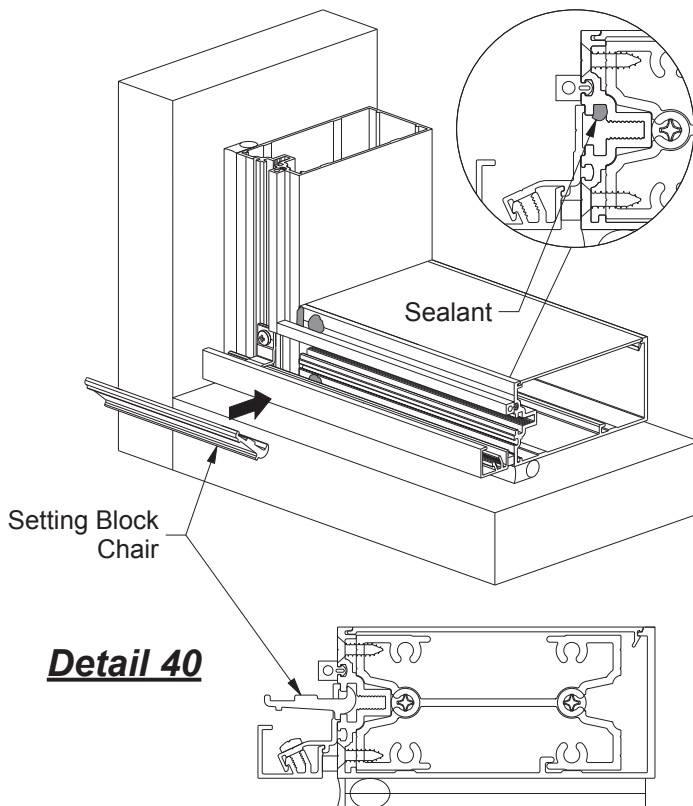

GLAZING

STEP 18 INSTALL GLASS

- Install glass at this time. See **Detail 42** for glass sizes.
 - As each lite is installed, attach temporary glass retainers E1-1294, in the middle of each horizontal and 6" from glass edge at each end.
 - Additionally, secure glass with temporary glass retainers every 2'-0" maximum vertically and horizontally.
- See **Detail 43**.

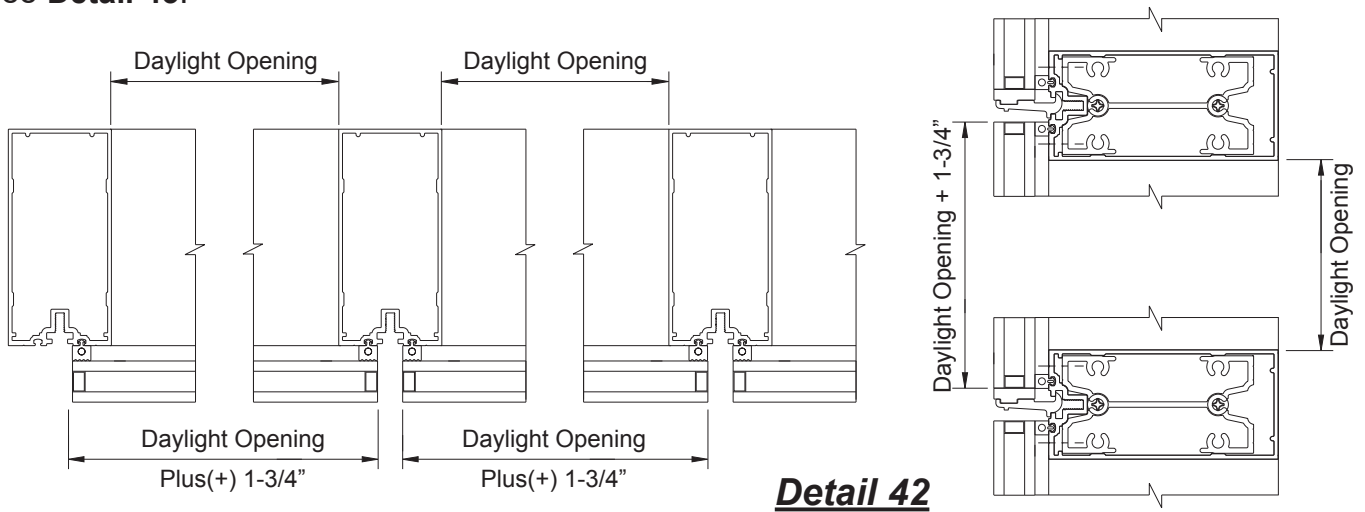

Detail 42

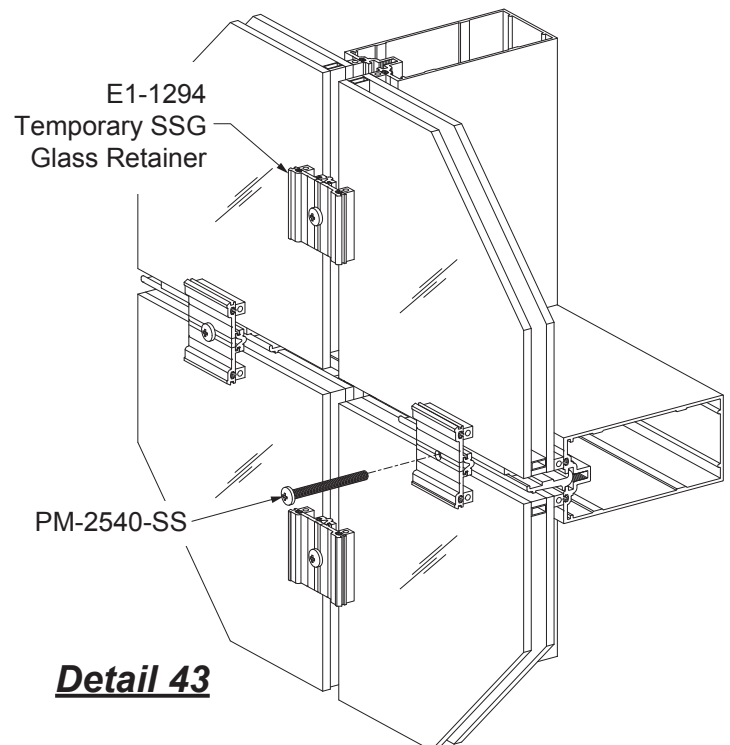

Detail 43

GLAZING

STEP 19

APPLY INTERIOR STRUCTURAL SILICONE SEALANT

- Carefully read and follow sealant manufacturers instructions.
- Make sure all silicone contact surfaces and joints have been cleaned with cleaner and method recommended by sealant manufacturer.
- Apply masking tape to the mullion and glass as shown in **Detail 44**.
- Apply an approved structural silicone from the bottom to the top of the joint. Use positive pressure to completely fill the cavity between the glass and mullion.
- Using a nylon spatula or other non-scratching implement, tool the silicone immediately after running the mullion joint. Exert positive pressure while tooling to ensure that the silicone completely fills the cavity.
- Be careful not to remove too much silicone when tooling. The silicone should make complete contact with the glass and aluminum surfaces. The finished joint should be flush with the edge of the mullions and horizontals. See **Detail 44**.
- Remove masking tape immediately after tooling before silicone skin forms.
- Allow silicone to cure as per manufacturer's recommendations. Temporary retainers should be left in place until silicone has fully cured. Contact structural silicone manufacturer for expected cure times.

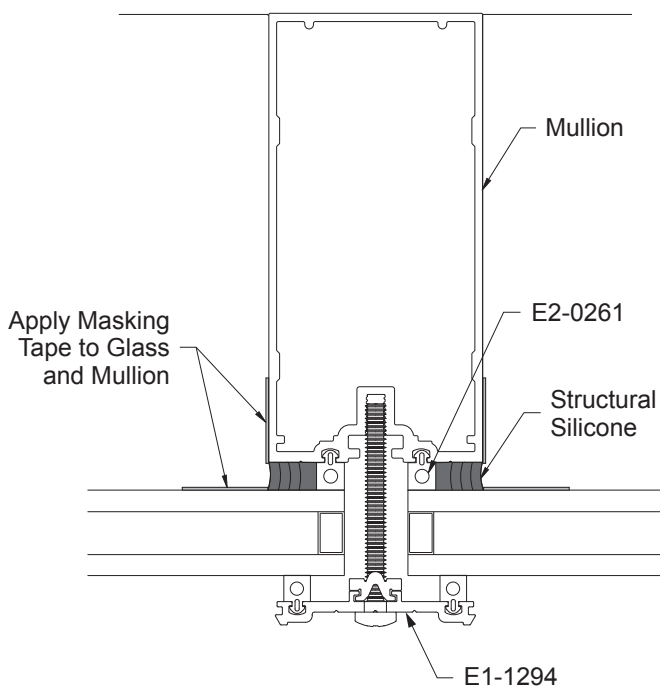

Detail 44

Caution: Do not permit the silicone to skin over before it is tooled. Immediately remove masking tape after tooling the silicone.

GLAZING

STEP 20 APPLY EXTERIOR WEATHERSEAL

- Once interior structural silicone has fully cured, remove the temporary retainer clips and insert backer rod between the lites of glass.
- Clean all silicone contact surfaces and joints with cleaner and method recommended by sealant manufacturer.
- Apply masking tape to the edges of the glass as shown in **Detail 45**.
- Apply silicone sealant into the cavity between the lites of glass. Use positive pressure so that the silicone sealant completely fills the cavity.
- Using a nylon spatula or other non-scratching implement, tool the silicone sealant immediately after running the joint. Exert positive pressure while tooling to ensure that the silicone sealant makes complete contact with all surfaces. Be careful not to remove too much silicone when tooling.
- Remove masking tape immediately after tooling before silicone skin forms.

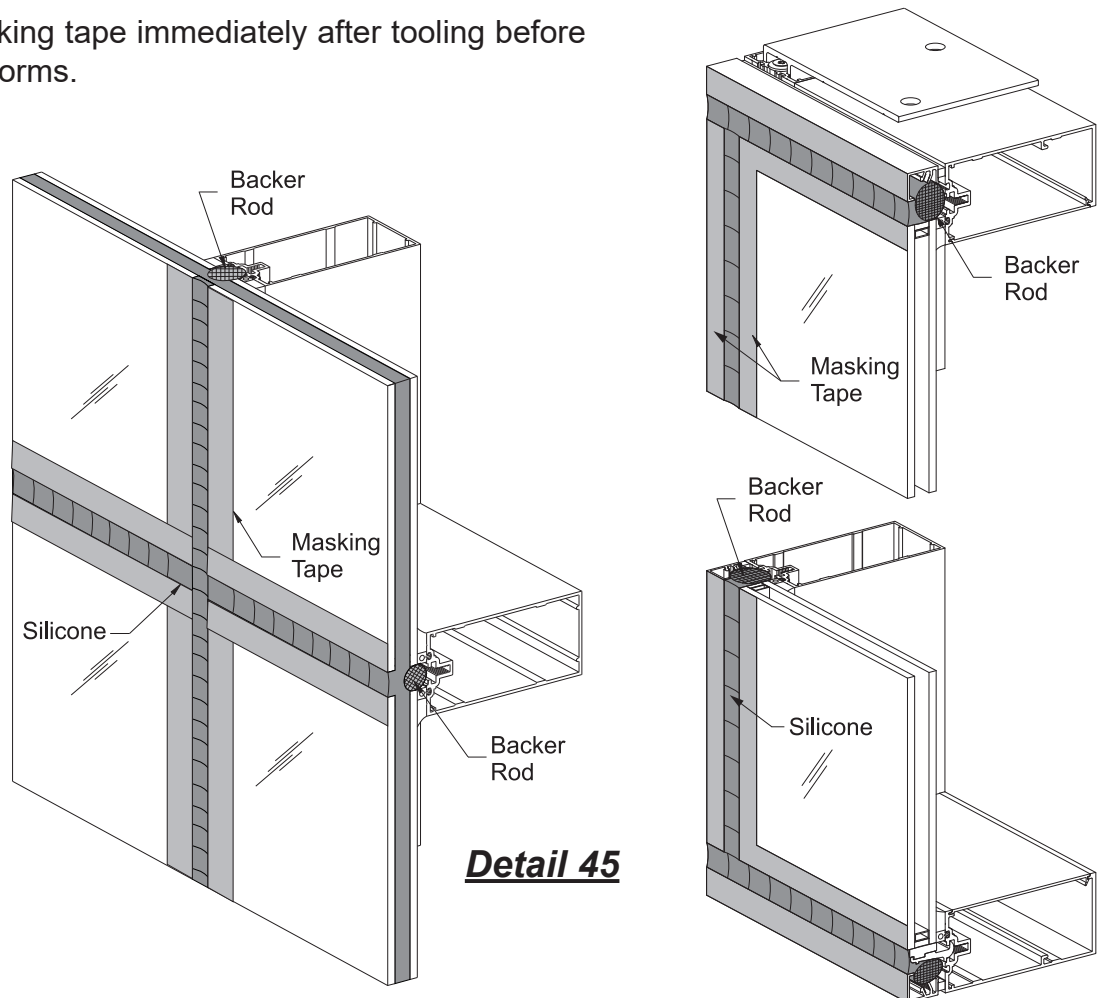

Caution: Do not permit the silicone to skin over before it is tooled. Immediately remove masking tape after tooling the silicone.

GLAZING

**STEP 21
INSTALL SECONDARY
PERIMETER SEALS**

- Carefully read and follow sealant manufacturers sealant recommendations.
- Make sure all silicone contact surfaces and joints have been cleaned with cleaner and method recommended by sealant manufacturer.
- Install backer rod and apply sealant to the areas indicated in **Detail 45**.
- Apply E3-0102 weep tubes, 2 per DLO at 1/4 points to allow any water condensation to weep to the exterior.

See **Detail 46**.

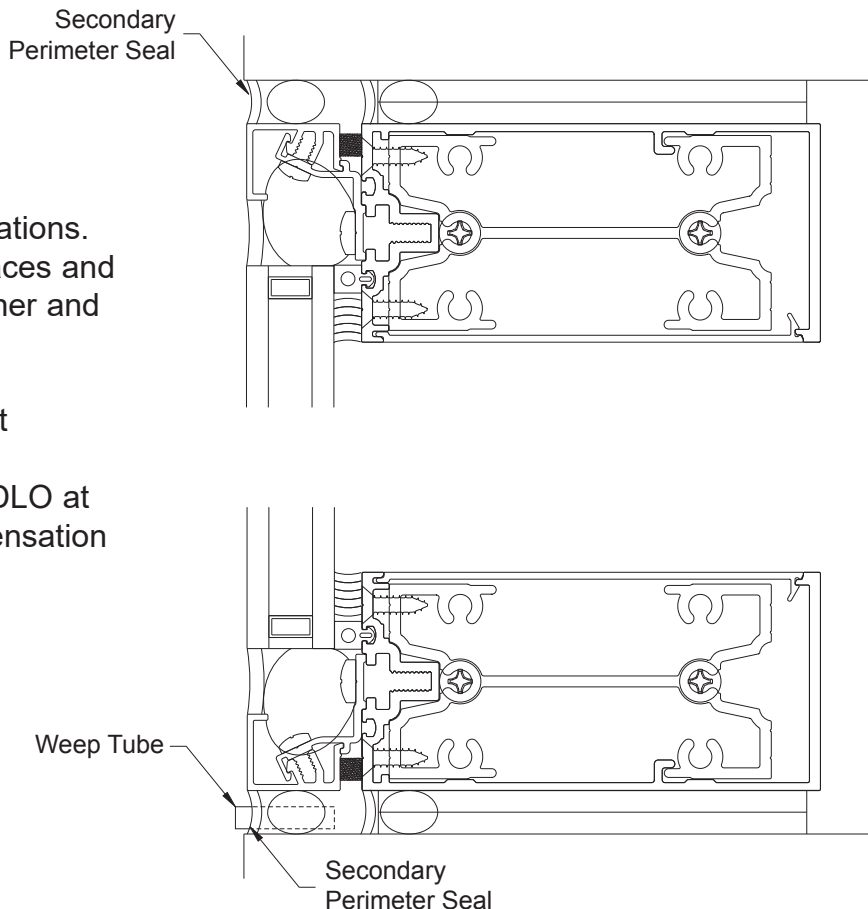

Detail 46

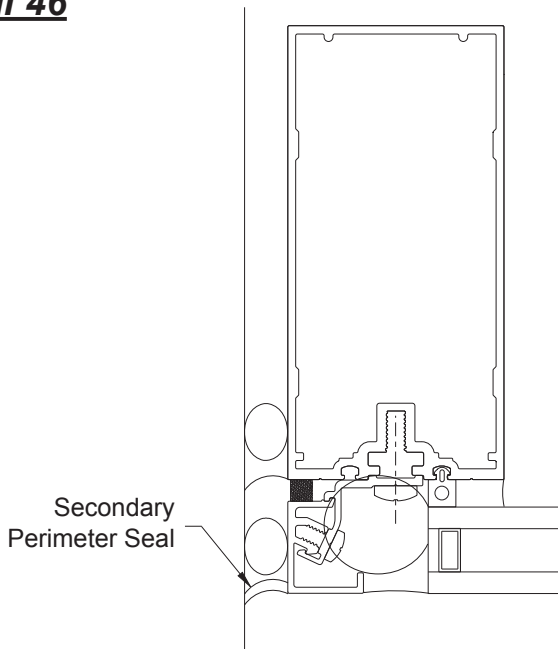

 **YKK AP America Inc.**

270 Riverside PKWY

Suite 100

Austell, Georgia 30168

www.ykkap.com