



Oldcastle BuildingEnvelope®

RELIANCE UNIT WALL ASSEMBLY & GLAZING INSTRUCTIONS

NOTE:

THE ASSEMBLY DETAILS FOUND IN THIS PACKAGE ARE GENERIC AND ARE FOR REPRESENTATION ONLY WITH THE INTENT OF GIVING THE ASSEMBLY TEAM A VISUAL REPRESENTATION AS TO HOW THE ASSEMBLIES TYPICALLY ASSEMBLE. THE SHOP SUBMISSION DRAWINGS AND DETAILS ARE THE GOVERNING DOCUMENTS AND AS SUCH THIS PACKAGE IS TO BE USED ONLY AS A RESOURCE.

FOLLOW STRUCTURAL GLAZING TAPE AND SEALANT MANUFACTURER'S RECOMMENDATIONS FOR USE AND APPLICATION OF THE STRUCTURAL GLAZING TAPE AND WEATHER SEAL.

NOTE: CUSTOMER / PROJECT QUALITY ASSURANCE PROCEDURES ARE SEPARATE DOCUMENTS AND ARE TO BE FOLLOWED IN CONJUNCTION WITH THIS MANUAL.

RELIANCE UNIT WALL - ASSEMBLY AND SEALING INSTRUCTIONS

| General Information | SHEET |
|---|--------------|
| Product Use | 1 |
| Protection and Storage | 1 |
| Check Material | 2 |
| Field Conditions | 2 |
| Cleaning Materials | 2 |
| Expansion Joints | 2 |
| | |
| Fabrication | |
| Cut to Length Material | 3 |
| Starter Sill Fabrication | 3 |
| Pressure Plate / Face Cap Cut Lengths | 4 |
| Stack Horizontal Fabrication | 5-7 |
| Captured Verticals / Corners (7" System) | 8-13 |
| Non Captured Verticals (7" System) | 14-17 |
| Captured Verticals / Corners (8" System) | 18-23 |
| Non Captured Verticals (8" System) | 24-27 |
| | |
| Vent / Drain Hole Location | 28 |
| | |
| Frame Assembly | |
| Layout Parts | 29 |
| Apply Silicone Sealant | 29 |
| Frame Assembly (captured) | 30 |
| Frame Assembly (Non Captured) | 31 |
| Frame Assembly at Stack | 32 |
| Sealant / Fastener Notes | 33 |
| | |
| Tape Application | 34 |
| | |
| Glass Installation | 35 |
| | |
| Pressure Plate / Face Cap Installation | |
| Vertical | 36 |
| Horizontal | 37 |
| | |
| Parts List | 38-40 |

RELIANCE UNIT WALL - ASSEMBLY AND SEALING INSTRUCTIONS

GENERAL INFORMATION

PRODUCT USE

Reliance Unit Wall Curtain Wall system is intended for assembly and installation by glazing professionals with appropriate experience. Subcontractors must be qualified to provide field instruction and project management.

Oldcastle BuildingEnvelope® does not control the application of its product configurations, sealant or glazing material and assumes no responsibility for the application. It is the responsibility of the owner, architect and installer to make these selections in strict compliance with applicable laws and building codes.

It is critical to involve 3M™ at the earliest stage of the project as possible. Building loads and glass sizes may be restricted based on structural capabilities of the tape used on project. Supplier must review shop drawings and make recommendations prior to ordering materials.

When using 3M™ VHB™ SGT you must involve 3M's™ technical services to obtain approval, and have SOP written for project specific materials, order materials and schedule training prior to assembling any window frames. (3M VHB must be purchased directly from distributor and is **NOT** provided by or sold through O.B.E.)

The air and water performance of the unitized curtain wall is directly related to the completeness and integrity of the assembly/glazing and installation process. Care must be taken when applying the seal at the horizontal to vertical connections as well as at the glazing tape installed on the interior side of the glass.

1. Surface to be sealed should be cleaned with isopropyl alcohol or solvent and dried as recommended by tape/sealant manufacturer to remove dirt and cutting oils. No gap should be visible in the sealant. Exposed surfaces should be cleaned of excess sealant after installing the horizontal. Inspect joint for complete sealant contact, especially where the horizontal meets the face of the vertical member.
2. The glazing tape should be installed so as to avoid stretching, buckles or tears. Cut the tape at corners (As shown on sheet 34). The glazing tape should be installed in one continuous piece per side, with seams/joints only at corners.

Variations on details shown may occur, but are not the responsibility of Oldcastle BuildingEnvelope.

PROTECTION AND STORAGE

Handle all material carefully. Do not drop from the truck. Stack with adequate separation so the material will not rub together. Store material off the ground, protecting against the elements and other construction hazards by using a well ventilated covering. Remove material from package if wet or located in a damp area. For further guidelines consult AAMA publication "Care And Handling of Architectural Aluminum From Shop To Site".

RELIANCE UNIT WALL - ASSEMBLY AND SEALING INSTRUCTIONS

CHECK MATERIAL

Check glass dimensions for overall size as well as thickness. Oldcastle BuildingEnvelope[®] cannot be held responsible for gaskets that are not water tight due to extreme glass tolerances. The unitized curtain wall system is designed to accommodate glass or panels measuring 1" in thickness (+/- 1/32").

Check all material upon arrival at job site for quality and to determine any shipping damage. Using the contract documents, completely check the surrounding conditions that will receive your materials. Notify the general contractor by letter of any discrepancies before proceeding with the work. Failure to do so constitutes acceptance of work by other trades.

Check shop drawings, installation instructions, architectural drawings and shipping lists to become familiar with the project. The shop drawings take precedence and include specific details for the project. The assembly and installation instructions are of a general nature and cover the most common conditions.

Due to varying job conditions all sealant must be approved by the sealant manufacturer to ensure it will perform per conditions shown on the instructions and shop drawings. The sealant must be compatible with all surfaces in which adhesion is required, including other sealant surfaces. Use primers where directed by sealant manufacturer. Properly store sealant at the recommended temperatures and check sealant for expiration and shelf life before using.

FIELD CONDITIONS

All material to be installed must be plumb, level and true. Aluminum to be placed in direct contact with masonry or incompatible material should be isolated with a heavy coat of zinc rich, bituminous paint or non-metallic material unless otherwise specified. After sealant is set and a representative amount of the wall has been glazed (250 sq. ft. or more), perform a water hose test in accordance with AAMA 501.2 "Field Check of Metal Storefront, Curtain Wall and Slope Glazing Systems for Water Leakage". On large projects the hose test must be repeated during the glazing operation. Review anchors or embeds in structure as early as possible to confirm that 'as built' building structure can accommodate anticipated anchor tolerances.

CLEANING MATERIALS

Cement, plaster terrazzo, alkaline and acid based materials used to clean masonry are very harmful to finishes. Any residue should be removed with water and mild soap immediately or permanent staining will occur. A spot test is recommended before any cleaning agent is used. Refer to the architectural finish guide in the detail catalog.

EXPANSION JOINTS

Expansion joints and perimeter joints shown in these instructions and in the shop drawings are shown at nominal size. Actual dimensions may vary due to perimeter conditions and/or differences in metal temperature between the time of fabrication and the time of assembly/installation. For example, a 12' unrestrained length of aluminum can expand or contract 3/32" over a temperature change of 50° F. Any movement potential should be accounted for at the time of the assembly and installation.

RELIANCE UNIT WALL - ASSEMBLY AND SEALING INSTRUCTIONS

MEASURING & CUTTING MATERIAL

Unless otherwise noted, the details shown in these instructions reflect 1 " glazing, and are representative of typical non corner conditions.

1.1 Measure ROUGH OPENING to determine FRAME WIDTH and FRAME HEIGHT dimensions. Allow 3/4" minimum clearance at jamb vertical & 1 1/4" at head frame installation.

1.2 Cut material to size.

Frame Members

Verticals

Vertical Pressure Plates

Vertical Face Covers

Vertical Pocket Filler (Non Capt.)

Vertical Pocket Filler Trim (Non Capt.)

Horizontals

Horizontal Interior Trim

Horizontal Stack

Horizontal Pocket Filler

Horizontal Pressure Plates

Horizontal Face Covers

Horizontal Pocket Filler (Non Capt.)

Horizontal Pocket Filler (Non Capt.)

Starter Sill

Reference Project Shop Drawings.

See Page 4 for Cut Lengths

See Page 4 for Cut Lengths

Mull Height

Mull Height

D.L.O.

D.L.O. minus 1/16"

D.L.O. plus 3 5/8" (jamb unit)

D.L.O. plus 2 1/4" (typ. unit)

D.L.O. plus 3 5/8" (jamb unit)

D.L.O. plus 2" (typ. unit)

D.L.O. minus 1/4"

D.L.O. minus 1/8"

D.L.O. plus 3 1/4" (jamb unit)

D.L.O. plus 1 1/2" (typ. unit)

Frame size w/ 1/4" splice joints

as required

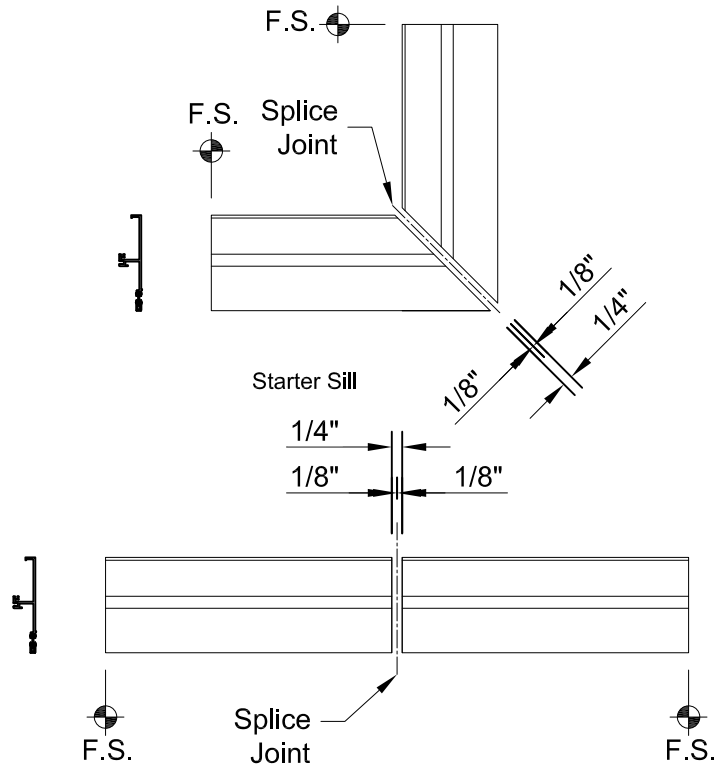
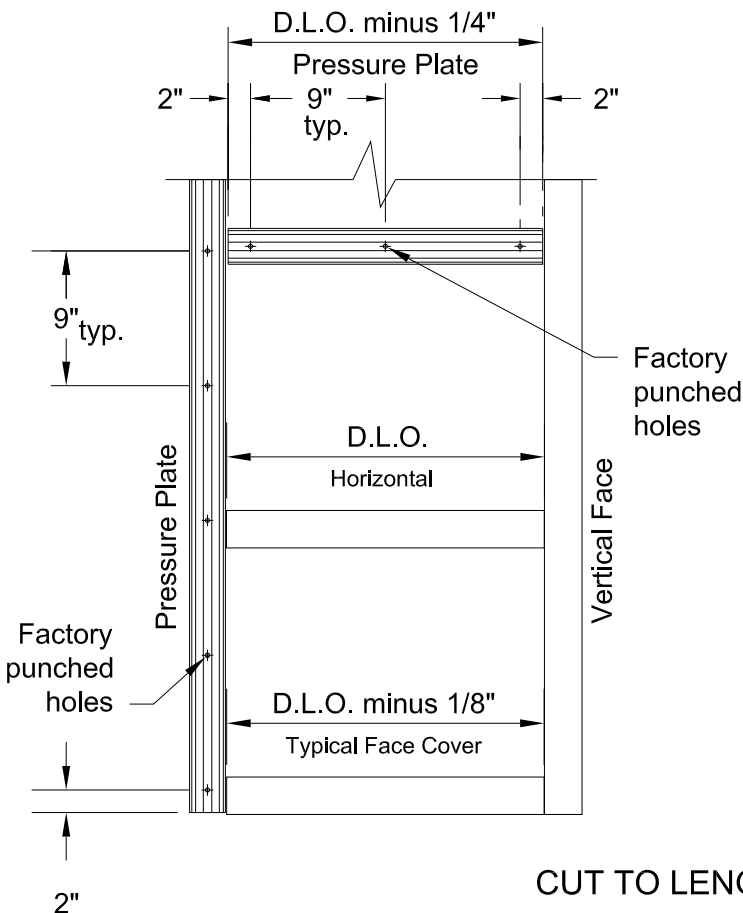

CUT TO LENGTH MATERIAL

RELIANCE UNIT WALL - ASSEMBLY AND SEALING INSTRUCTIONS

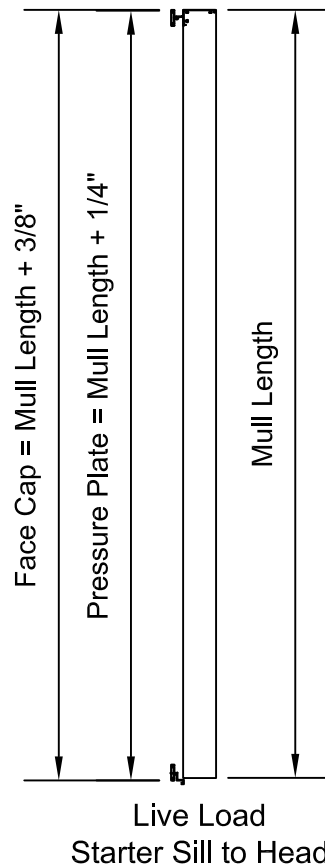
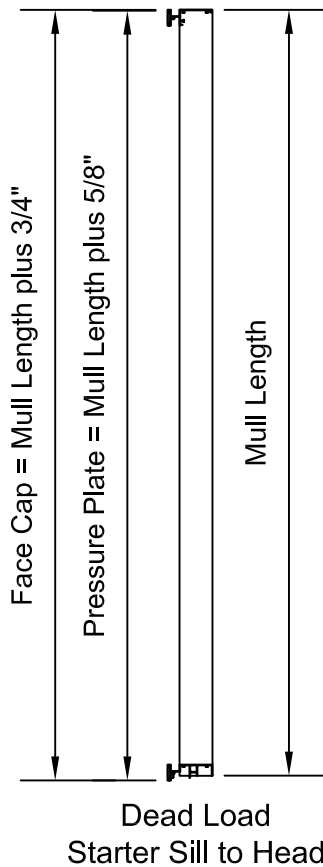
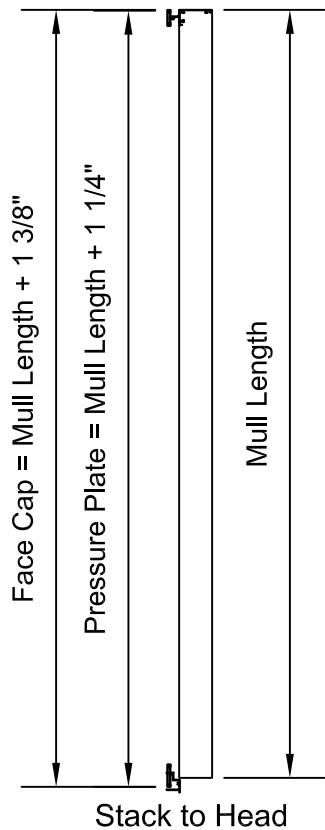
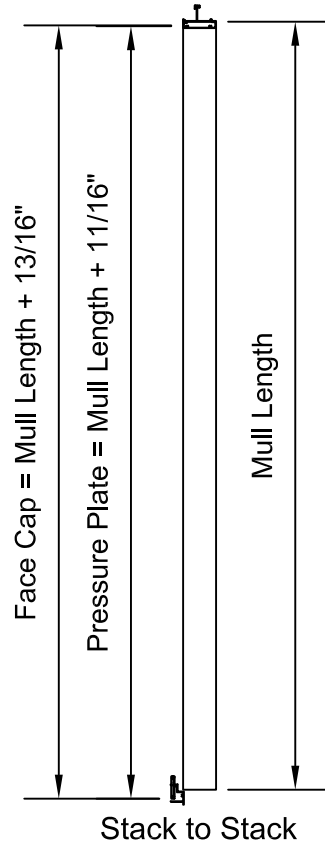
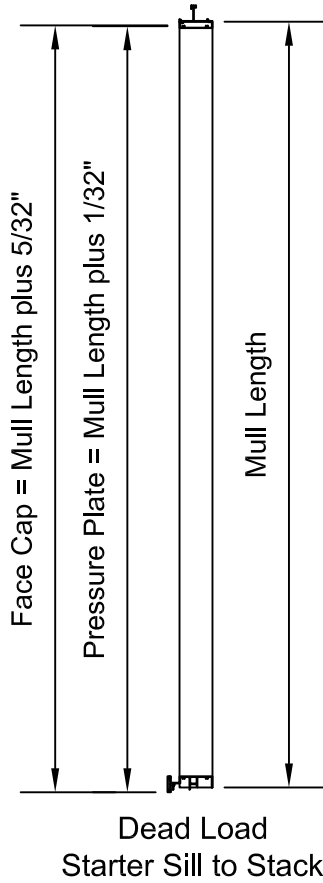
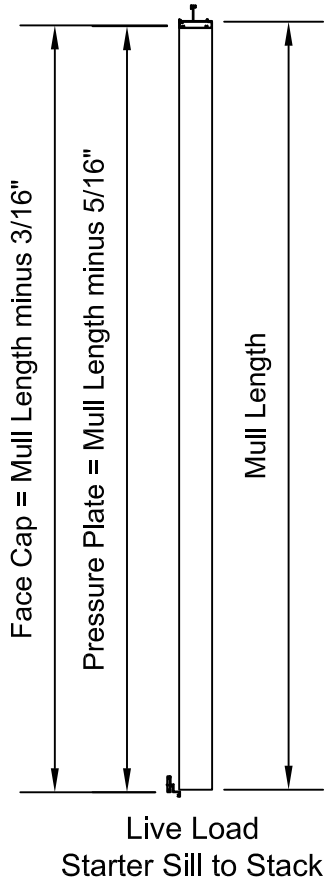

PRESSURE PLATE / FACE CAP CUT LENGTHS

RELIANCE UNIT WALL - ASSEMBLY AND SEALING INSTRUCTIONS

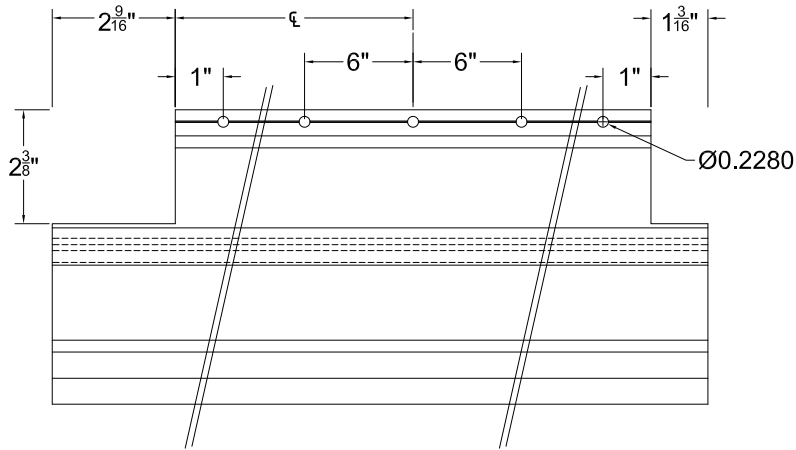

JAMB

MULL

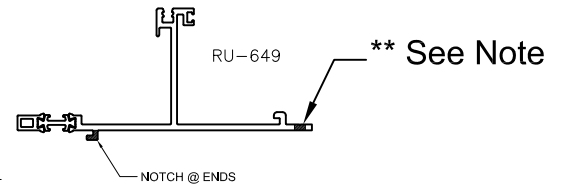
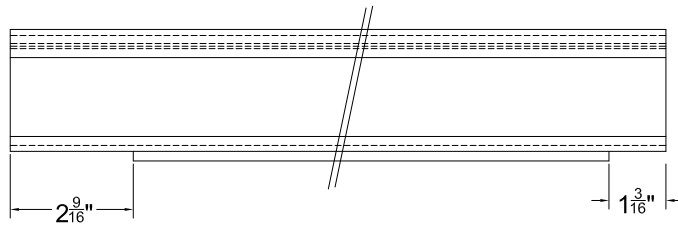
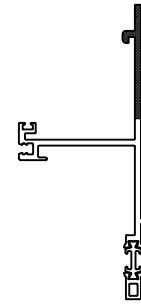

****Additional fasteners may be required to meet project specific structural requirements.**

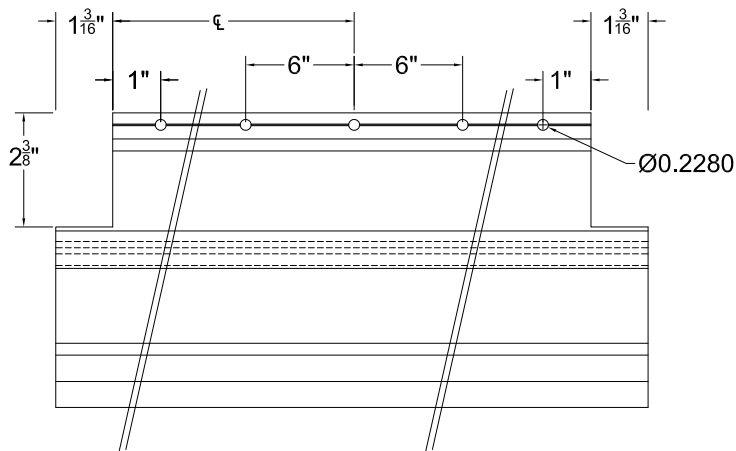

MULL

MULL

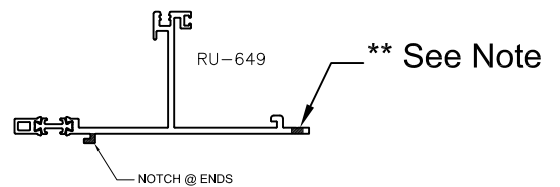
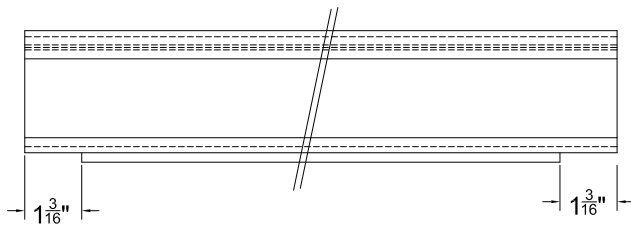
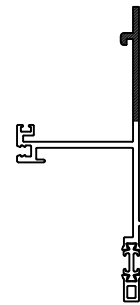

7" HORIZONTAL REFERENCE INFORMATION

RELIANCE UNIT WALL - ASSEMBLY AND SEALING INSTRUCTIONS

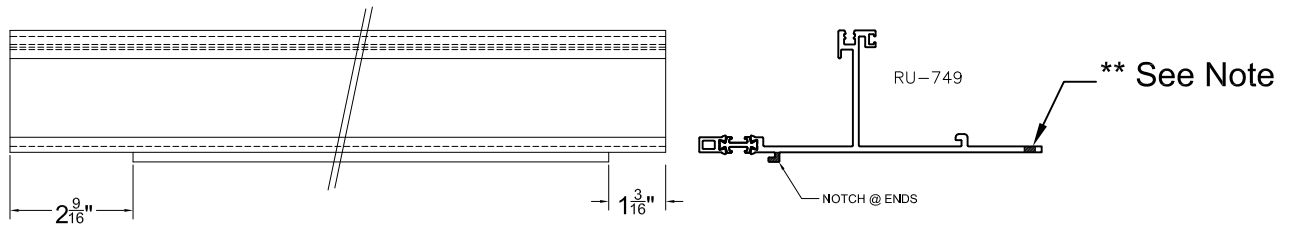
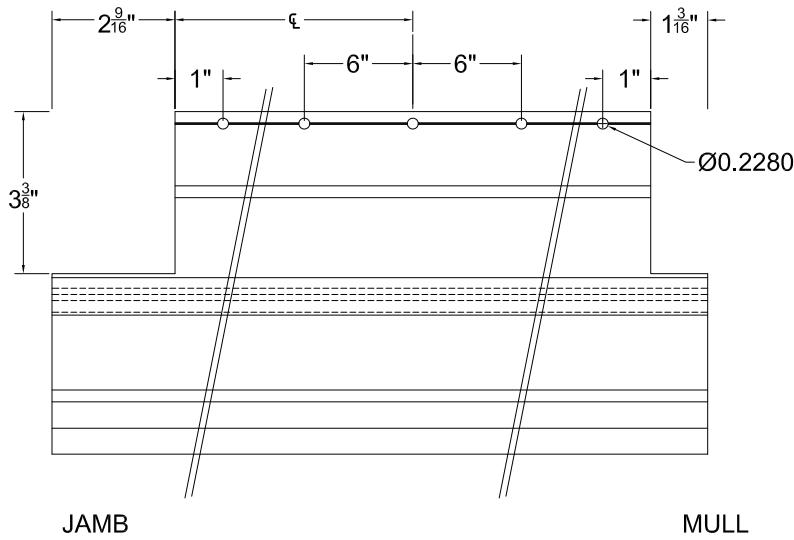

**Additional fasteners may be required to meet project specific structural requirements.

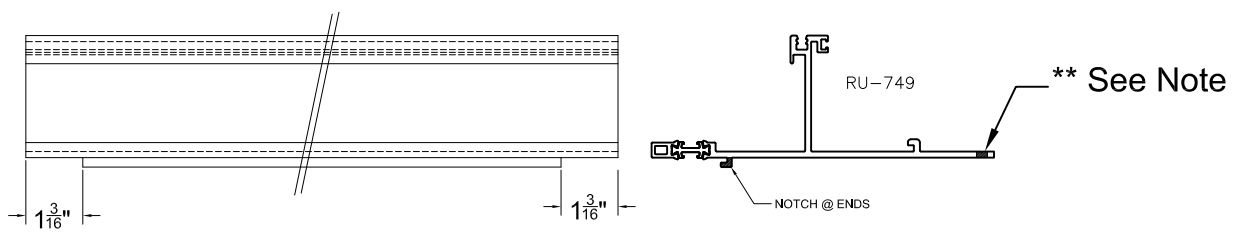
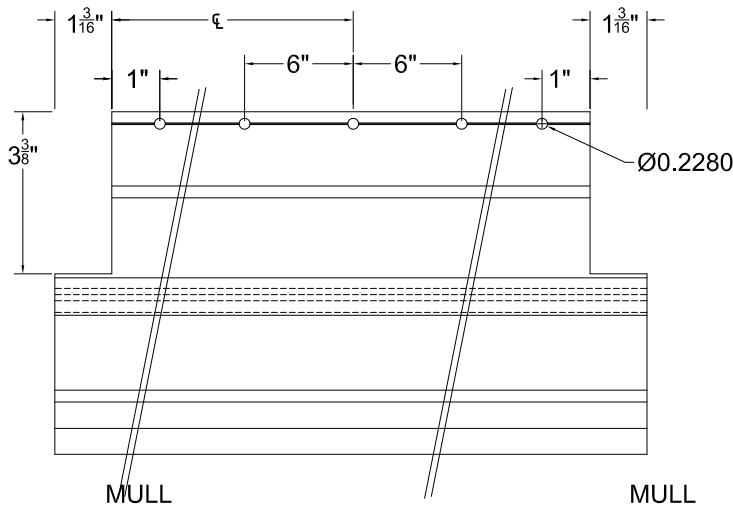

8" HORIZONTAL REFERENCE INFORMATION

RELIANCE UNIT WALL - ASSEMBLY AND SEALING INSTRUCTIONS

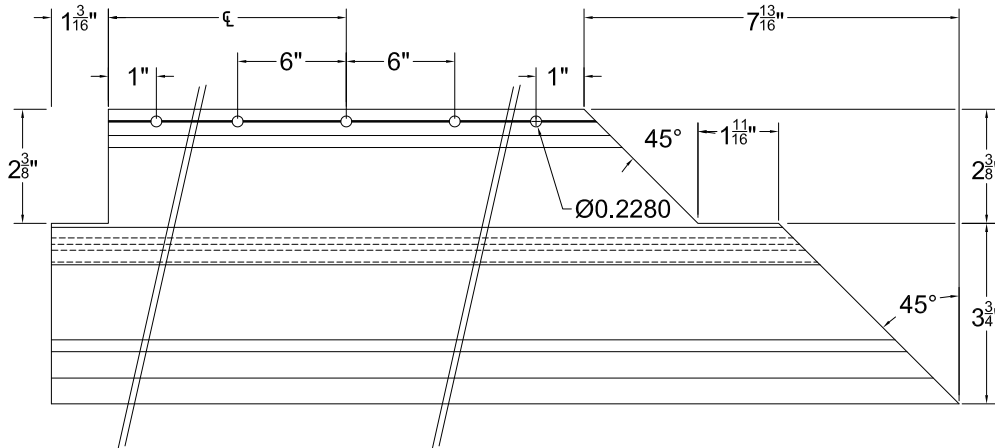

MULL

90° CORNER

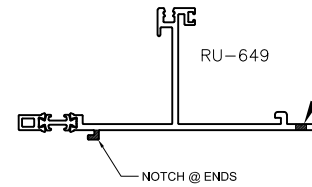
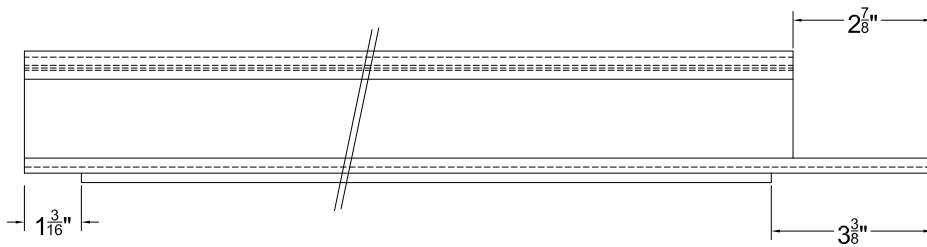
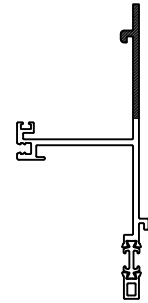

** See Note

7 1/4" HORIZONTAL REFERENCE INFORMATION

**Additional fasteners may be required to meet project specific structural requirements.

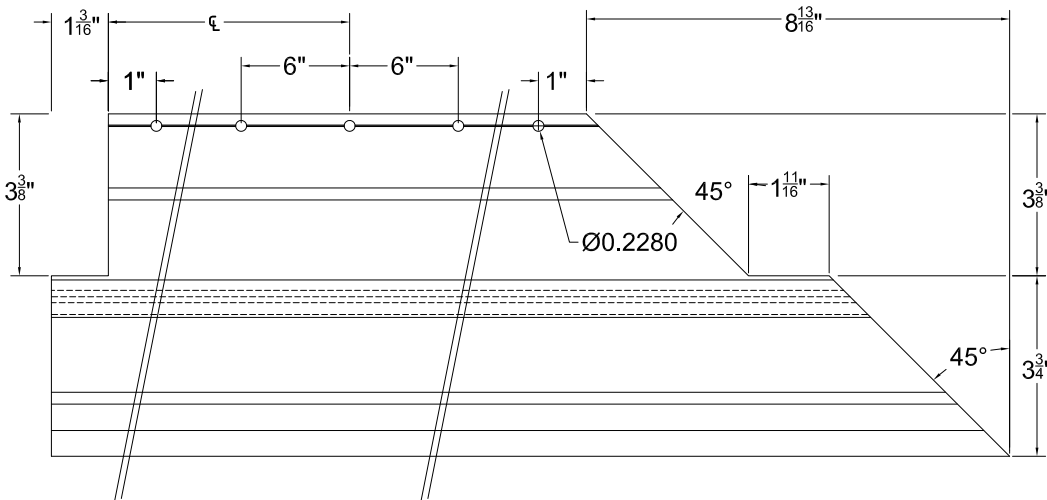

MULL

90° CORNER

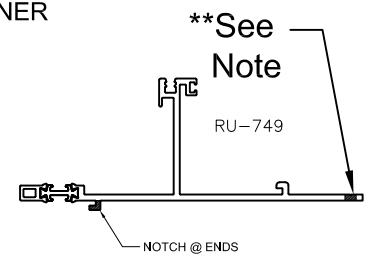
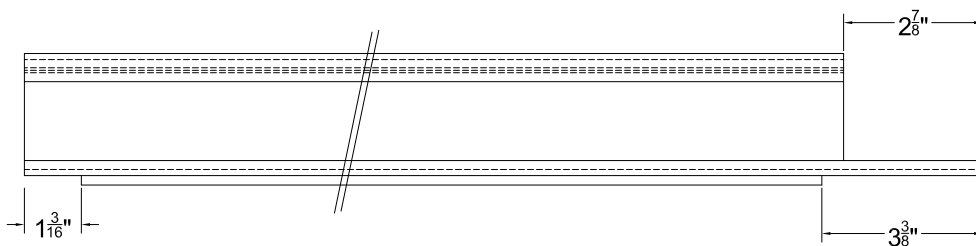
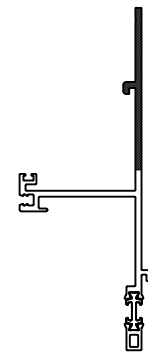

**See Note

8" HORIZONTAL REFERENCE INFORMATION

RELIANCE UNIT WALL - ASSEMBLY AND SEALING INSTRUCTIONS

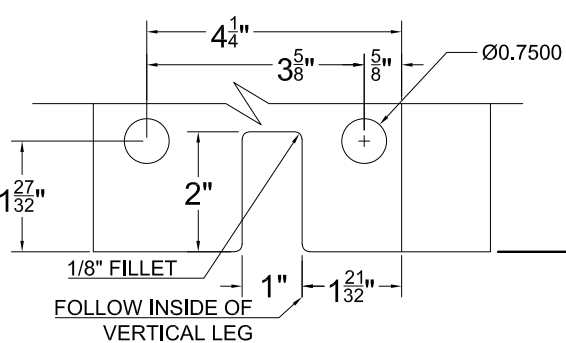
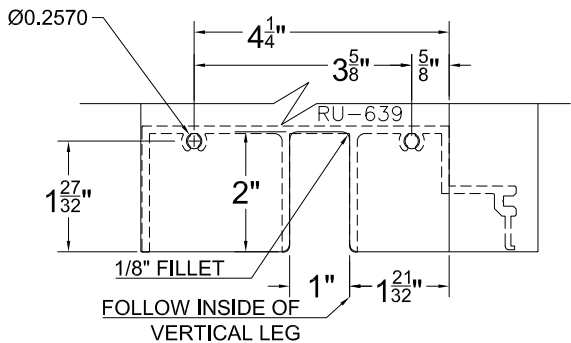
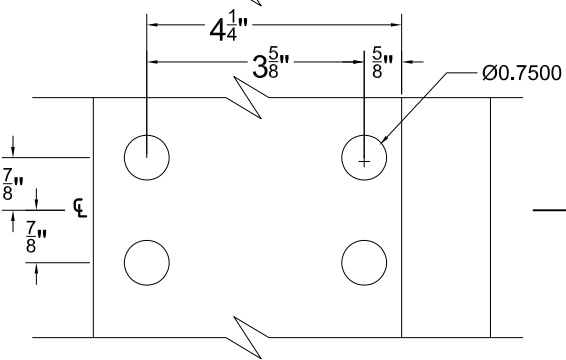
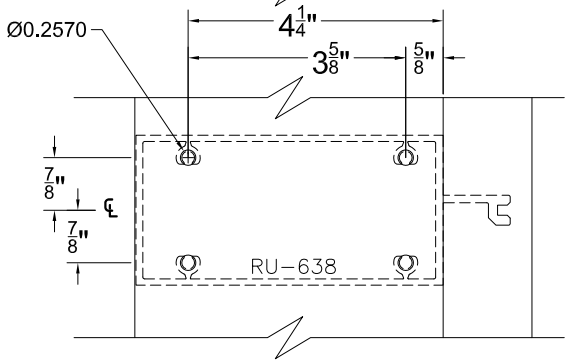
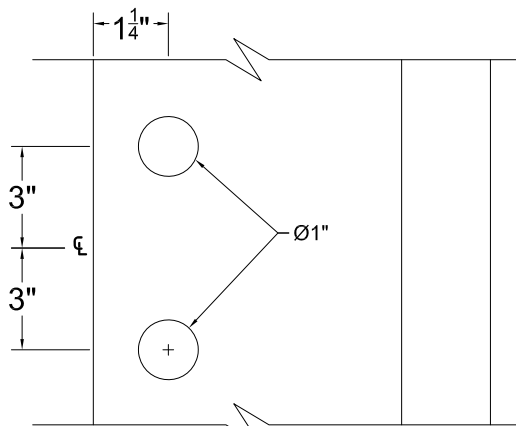
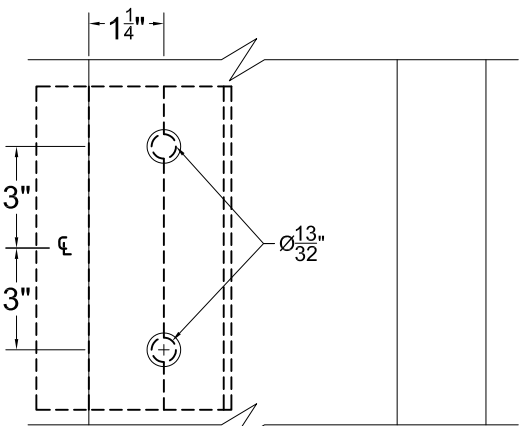
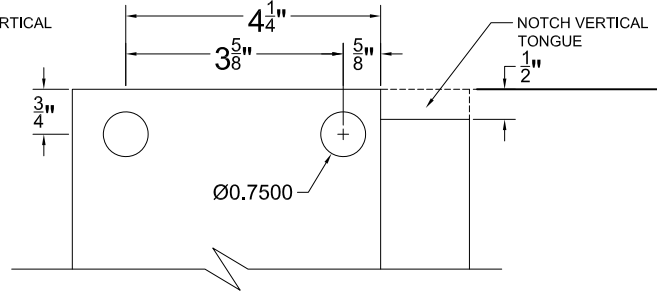
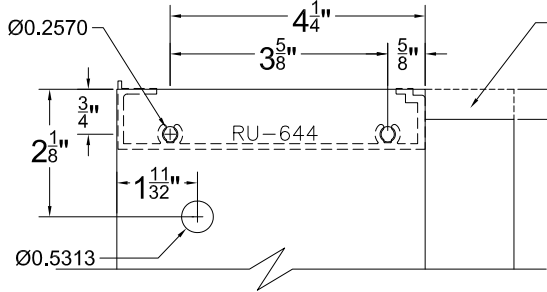
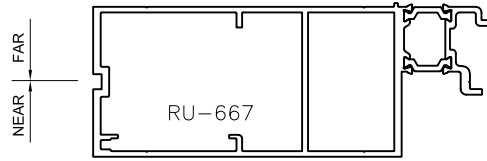
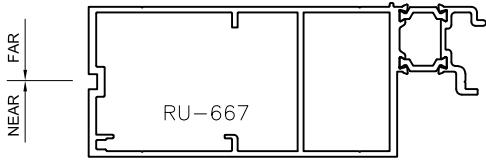

NEAR SIDE PREPS

FAR SIDE PREPS

7" VERTICAL REFERENCE INFORMATION (CAPTURED JAMB)

ϵ OF INT. HORIZONTAL
 ϵ OF ANCHOR LOCATION (TYP. ANCHOR)
 MULLION LENGTH

RELIANCE UNIT WALL - ASSEMBLY AND SEALING INSTRUCTIONS

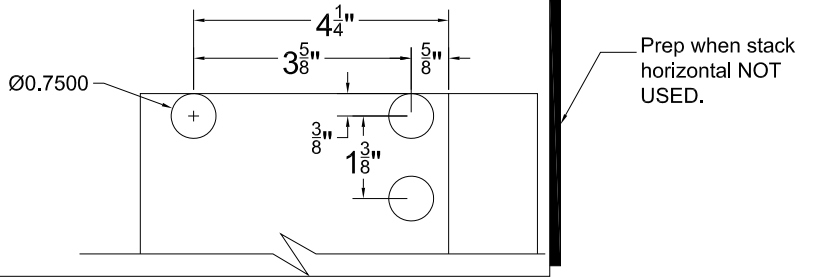
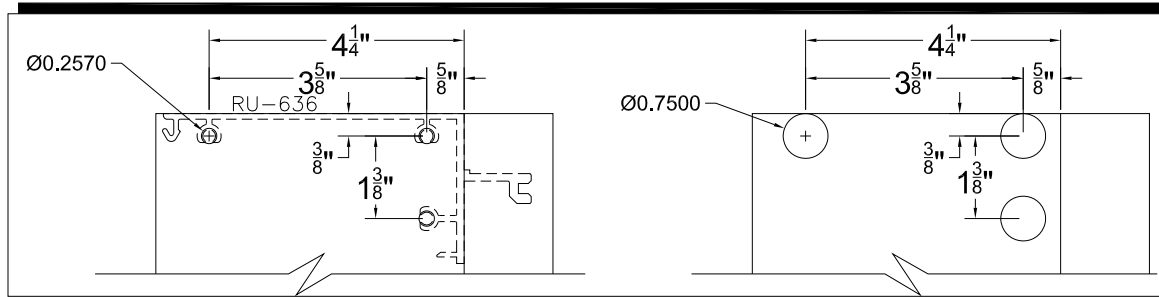
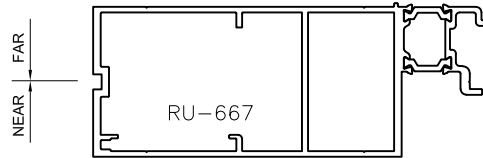
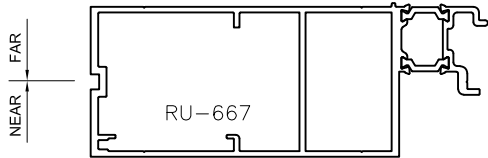

Prep when stack horizontal NOT USED.

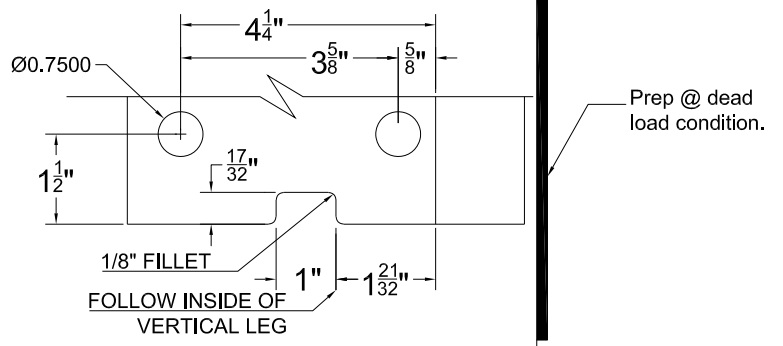
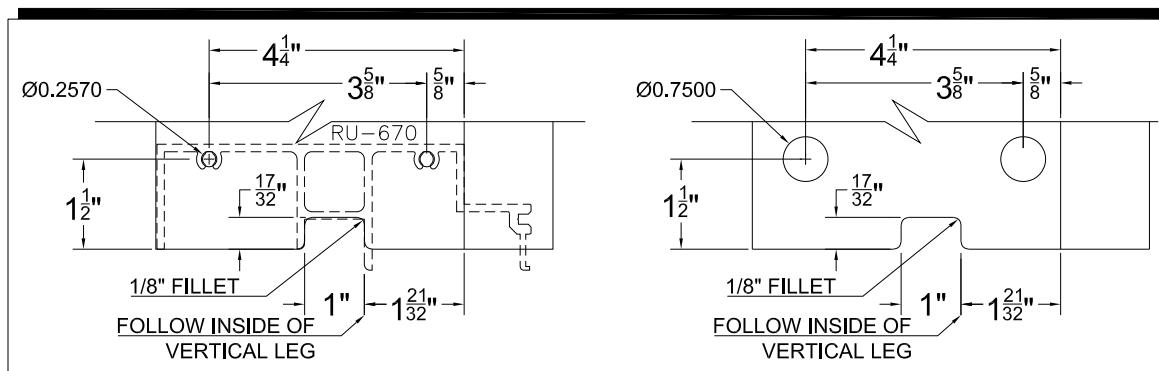

Prep @ dead load condition.

RELIANCE UNIT WALL - ASSEMBLY AND SEALING INSTRUCTIONS

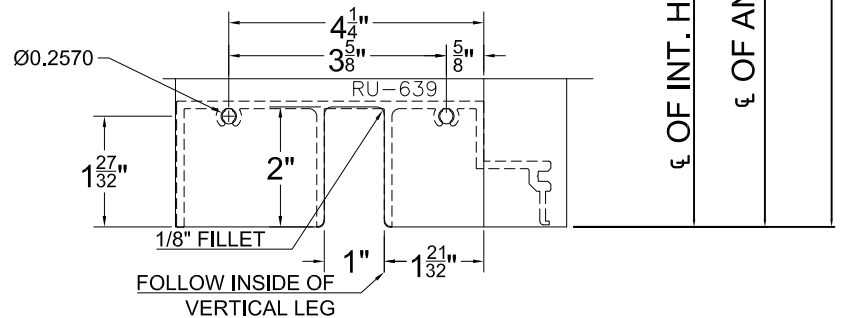
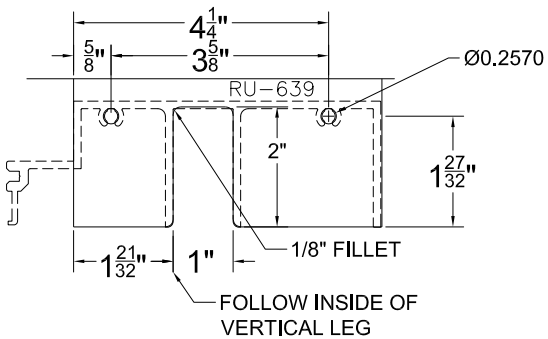
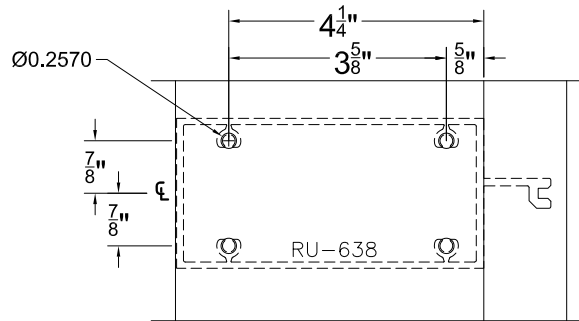
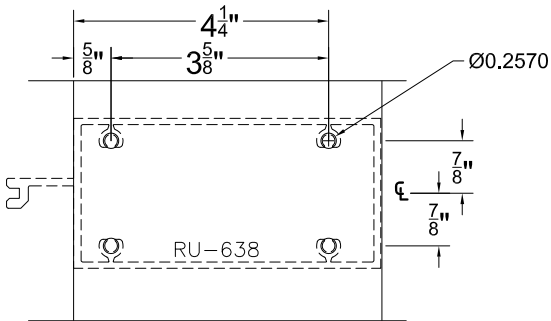
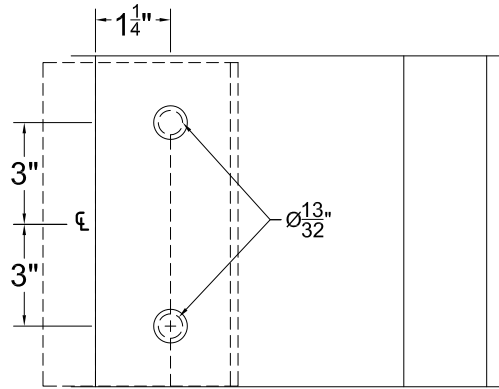
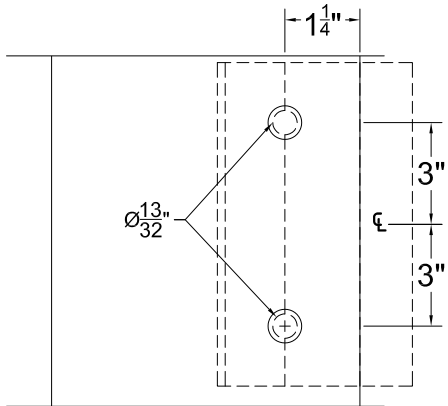
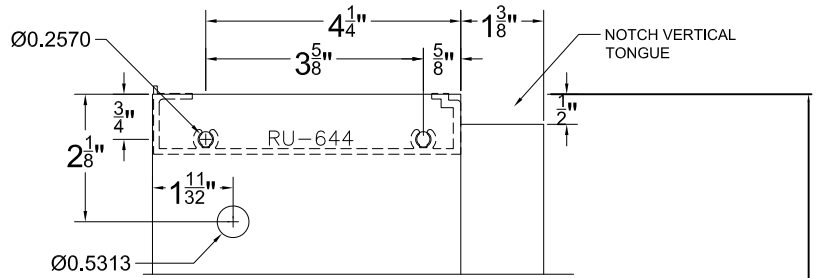
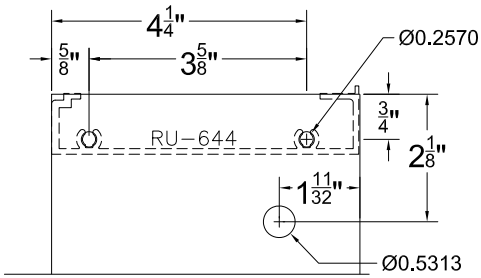
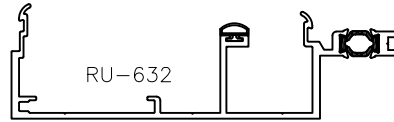
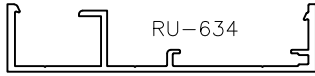

7" VERTICAL REFERENCE INFORMATION (CAPTURED INTERMEDIATE MULL)

RELIANCE UNIT WALL - ASSEMBLY AND SEALING INSTRUCTIONS

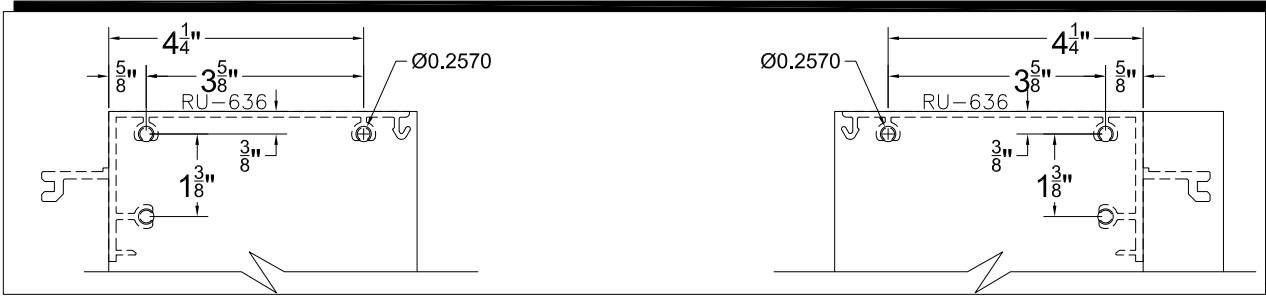
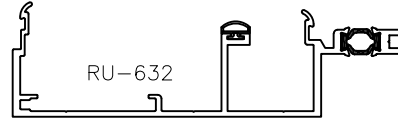
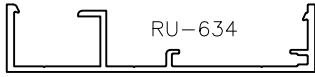

Prep when stack horizontal NOT USED.

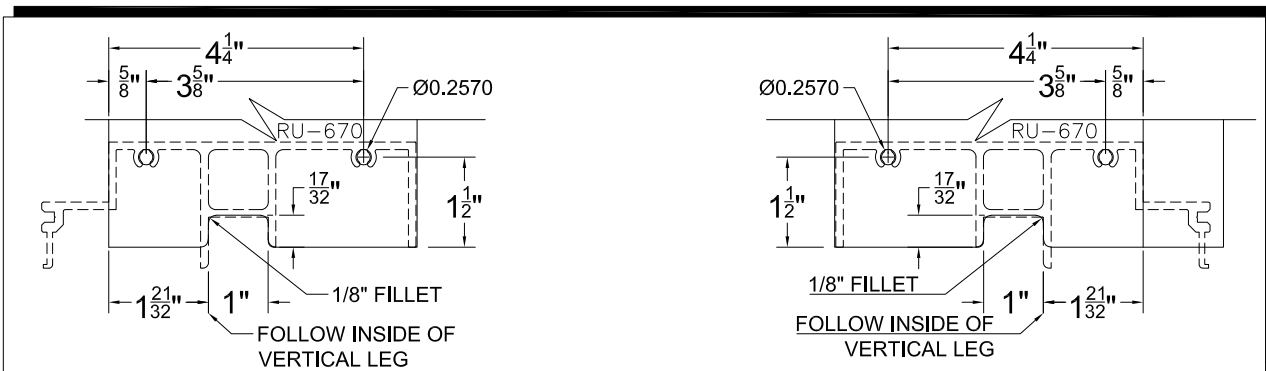

Prep @ dead load condition.

RELIANCE UNIT WALL - ASSEMBLY AND SEALING INSTRUCTIONS

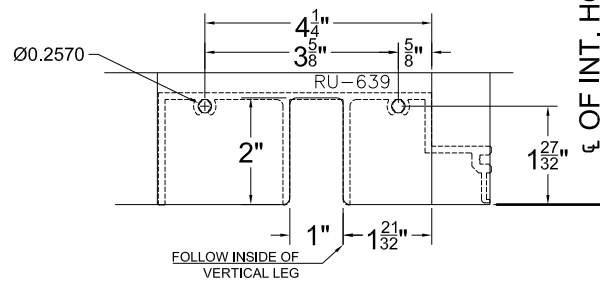
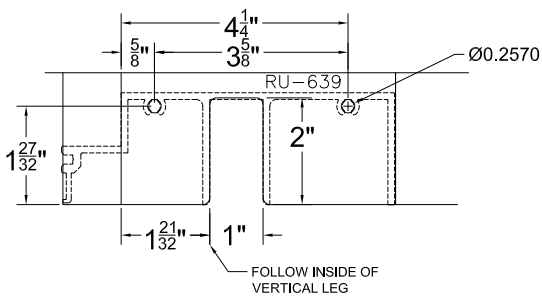
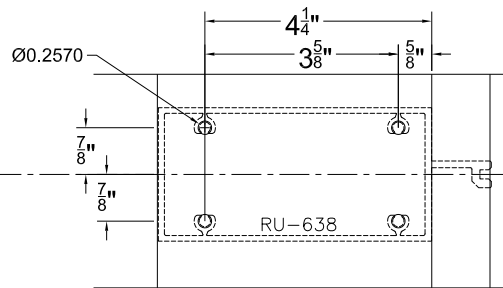
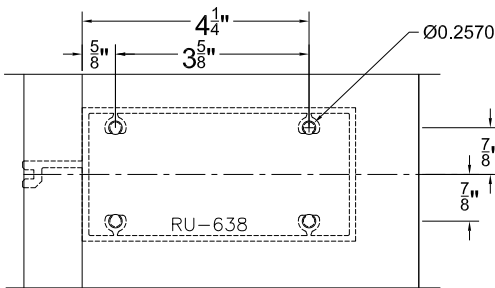
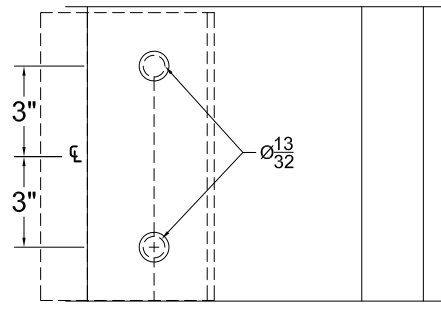
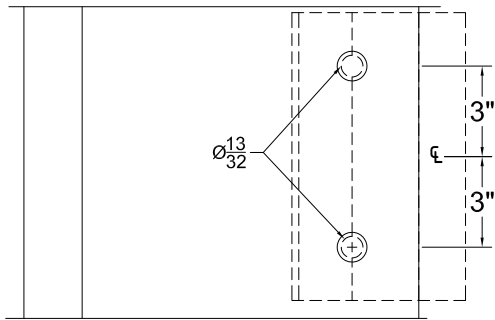
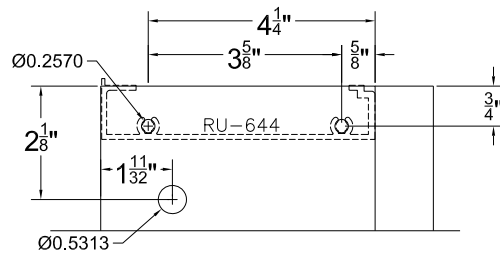
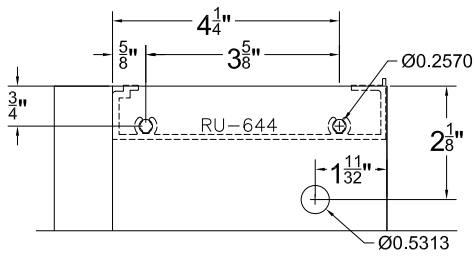
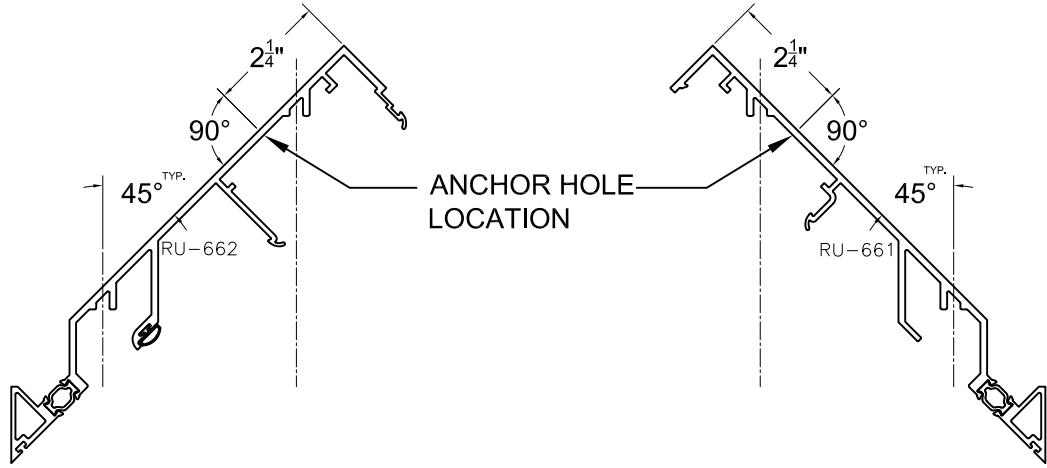

€ OF ANCHOR LOCATION (TYP. ANCHOR)

MULLION LENGTH

€ OF INT. HORIZONTAL

7" VERTICAL REFERENCE INFORMATION (CAPTURED O.S. 90° MULL)

RELIANCE UNIT WALL - ASSEMBLY AND SEALING INSTRUCTIONS

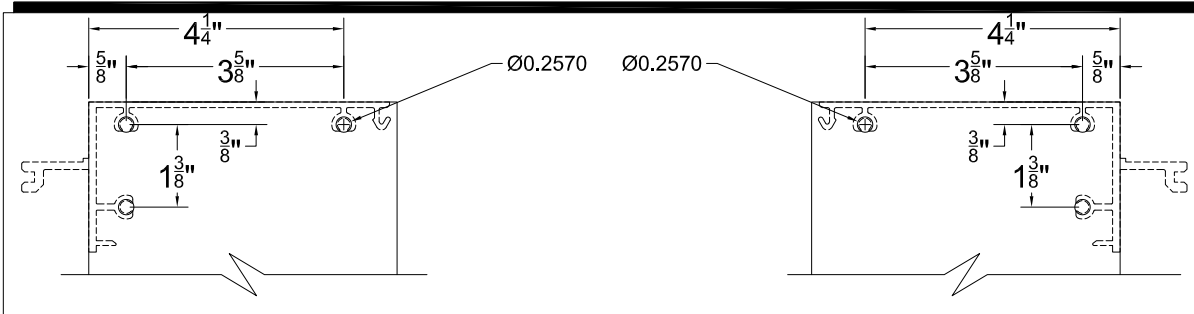
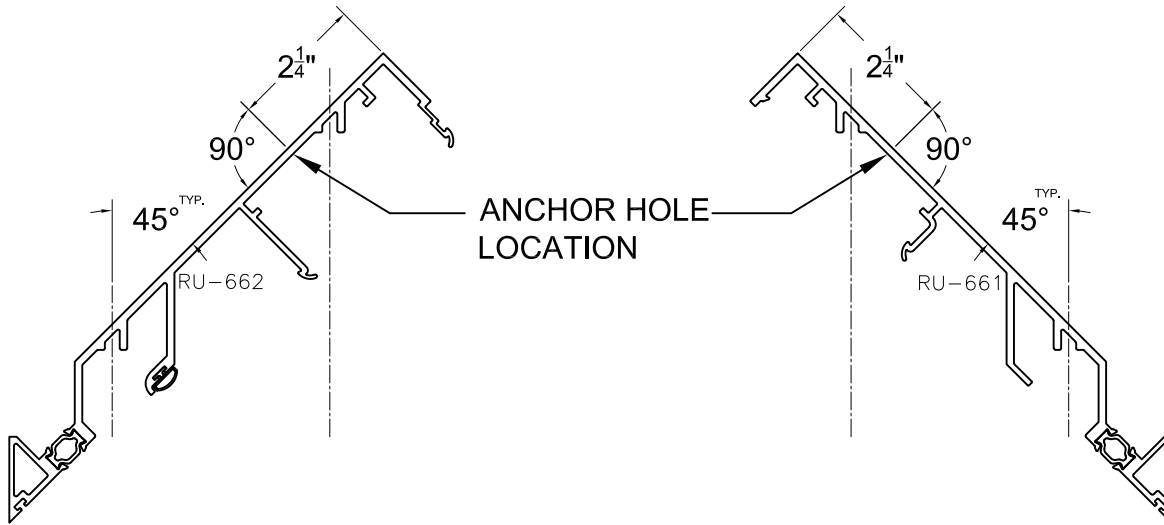

Prep when stack horizontal NOT USED.

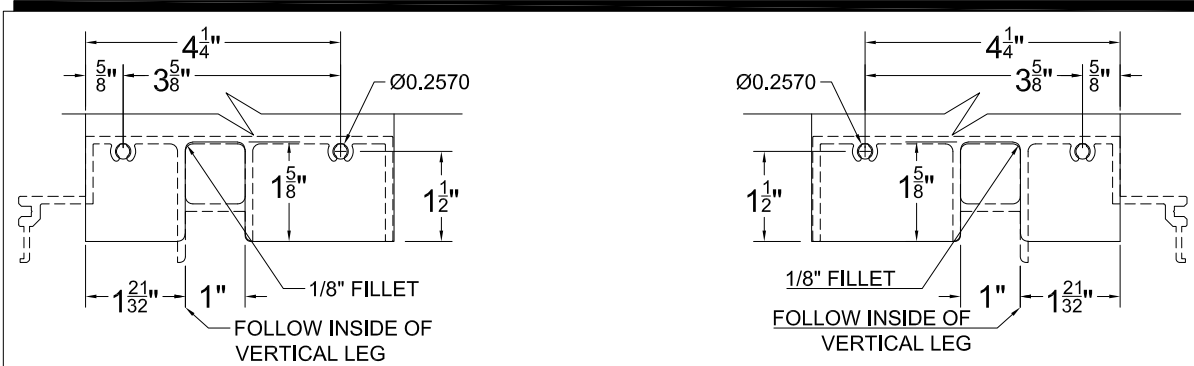

Prep @ dead load condition.

7" VERTICAL REFERENCE INFORMATION (CAPTURED O.S. 90° MULL)

RELIANCE UNIT WALL - ASSEMBLY AND SEALING INSTRUCTIONS

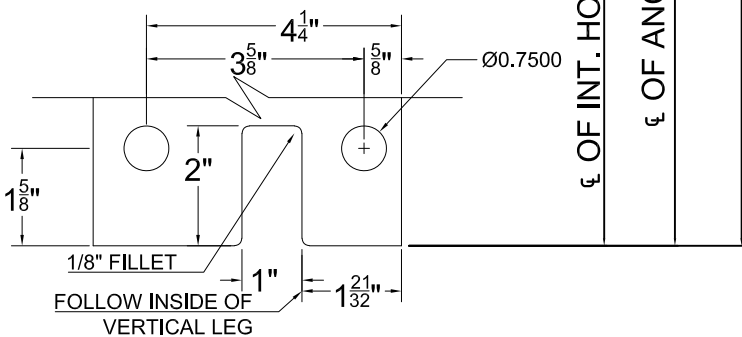
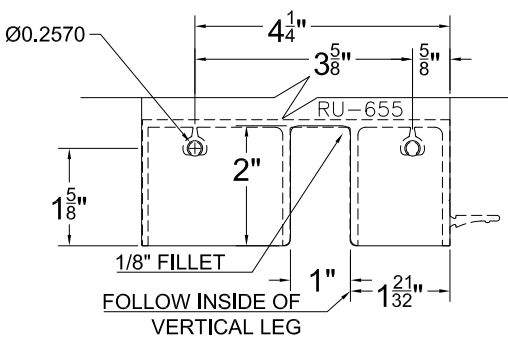
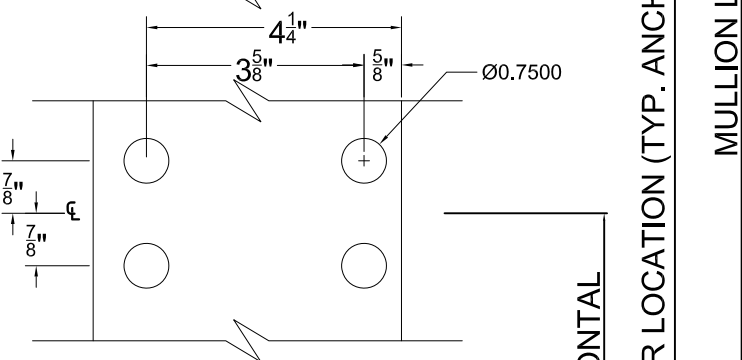
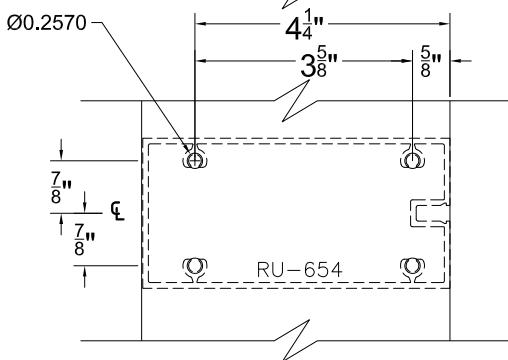
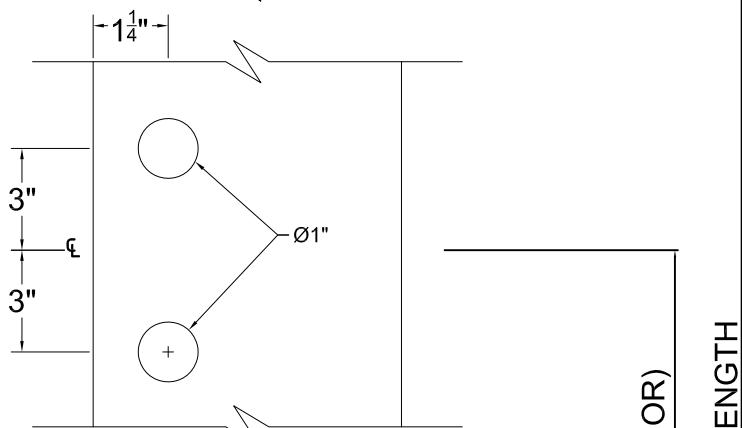
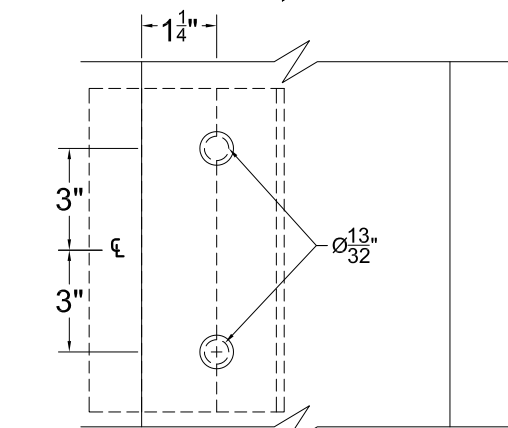
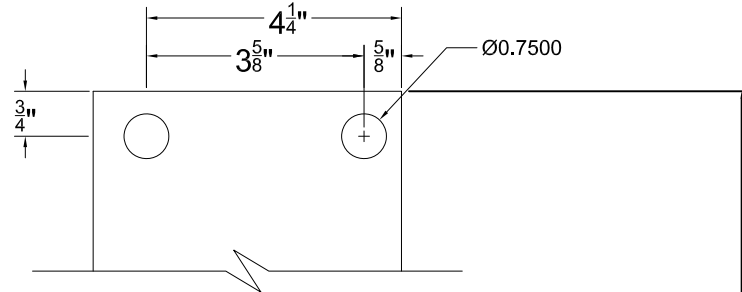
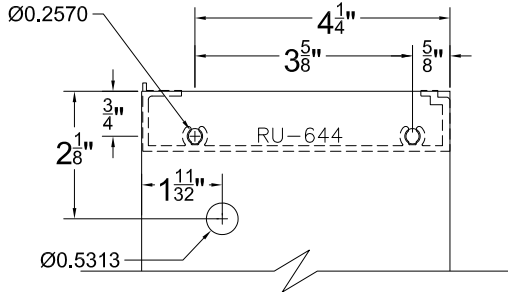
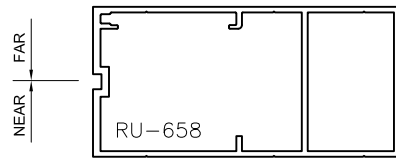
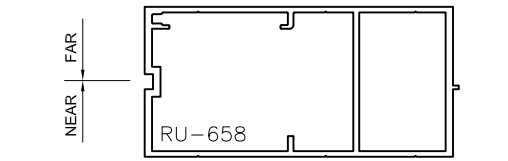

NEAR SIDE PREPS

FAR SIDE PREPS

7" VERTICAL REFERENCE INFORMATION (NON CAPTURED JAMB)

RELIANCE UNIT WALL - ASSEMBLY AND SEALING INSTRUCTIONS

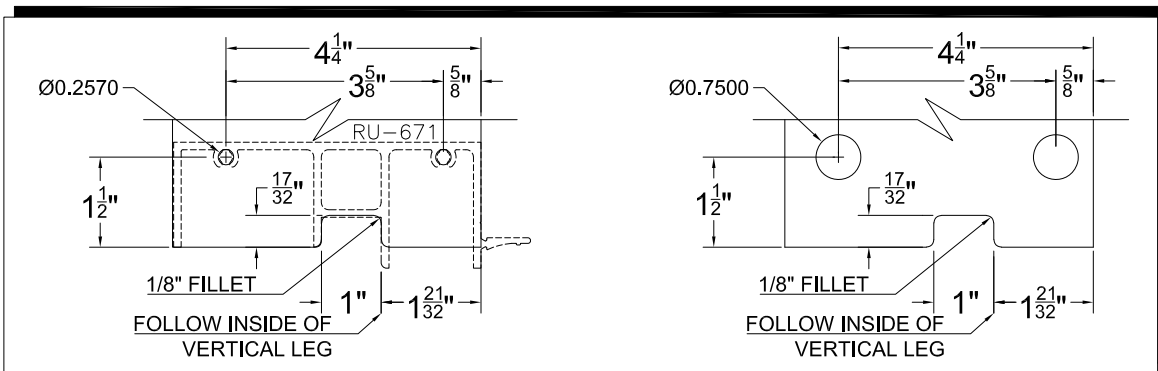
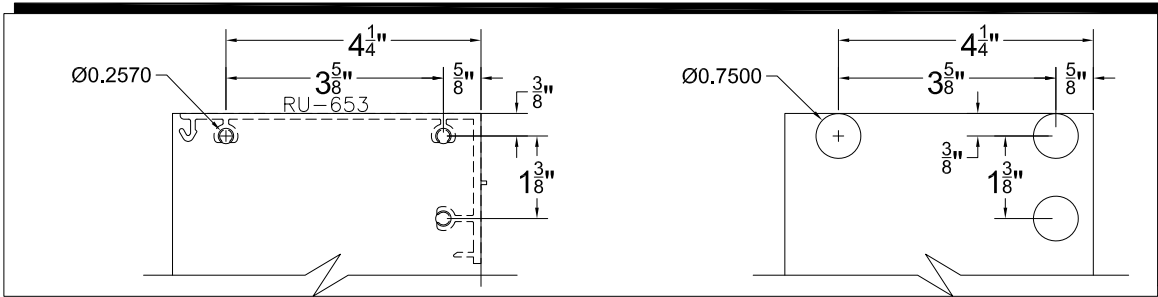
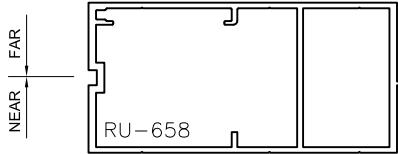

7" VERTICAL REFERENCE INFORMATION (NON CAPTURED JAMB)

RELIANCE UNIT WALL - ASSEMBLY AND SEALING INSTRUCTIONS

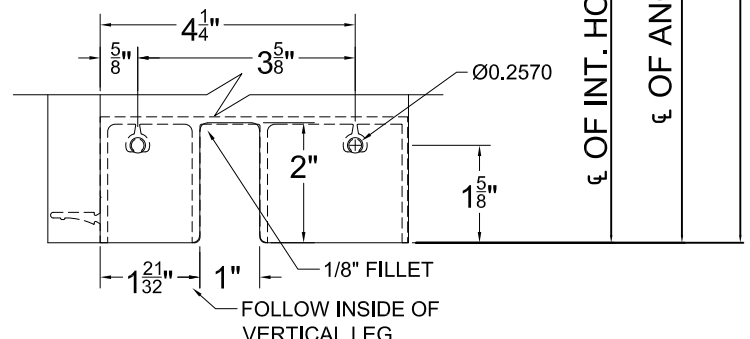
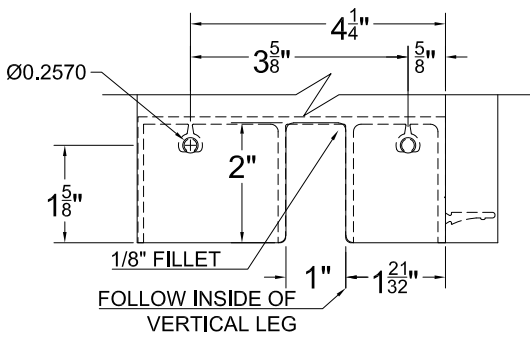
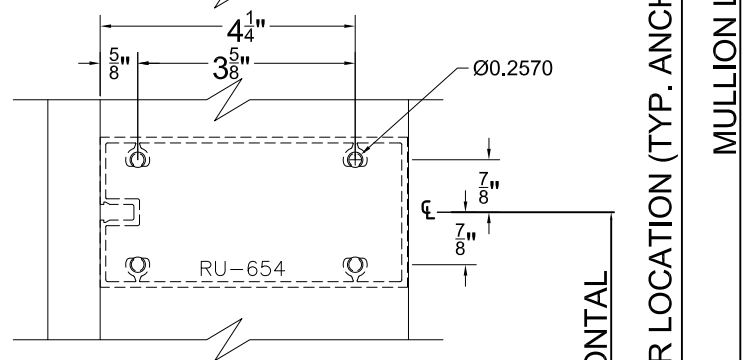
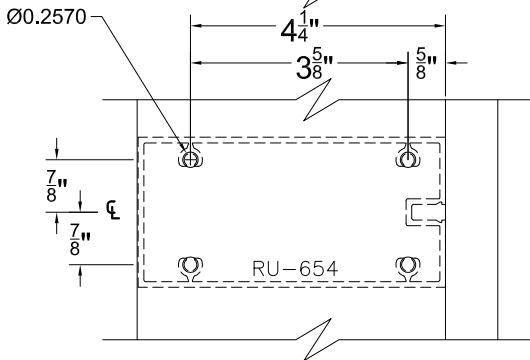
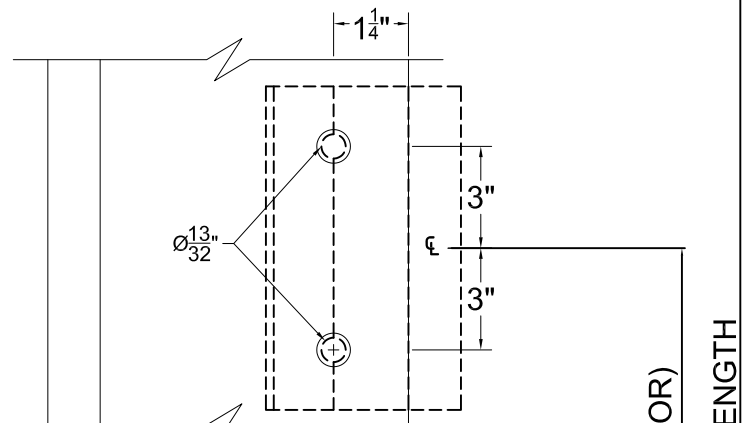
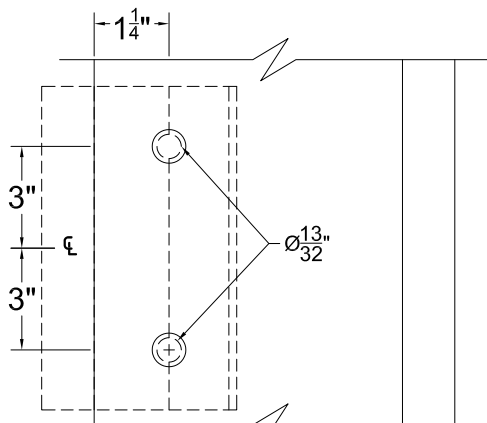
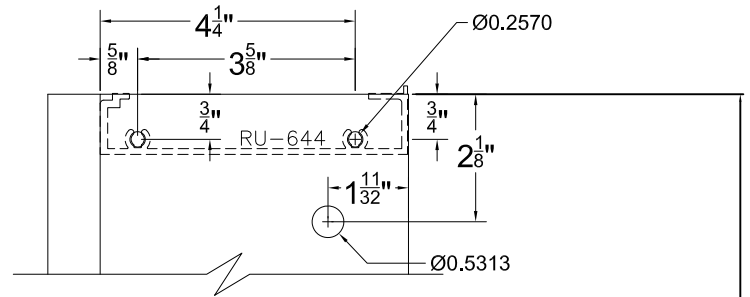
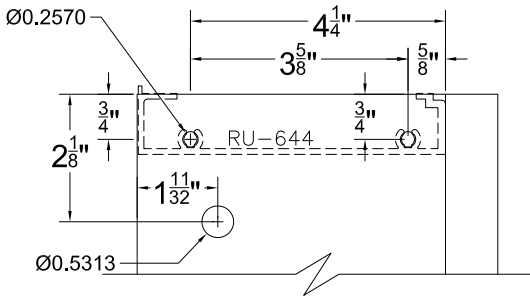
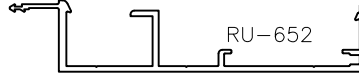
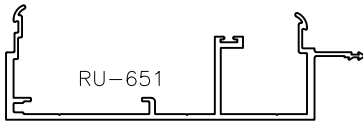

€ OF INT. HORIZONTAL
 € OF ANCHOR LOCATION (TYP. ANCHOR)
 MULLION LENGTH

7" VERTICAL REFERENCE INFORMATION (NON CAPTURED INTERMEDIATE MULLS)

RELIANCE UNIT WALL - ASSEMBLY AND SEALING INSTRUCTIONS

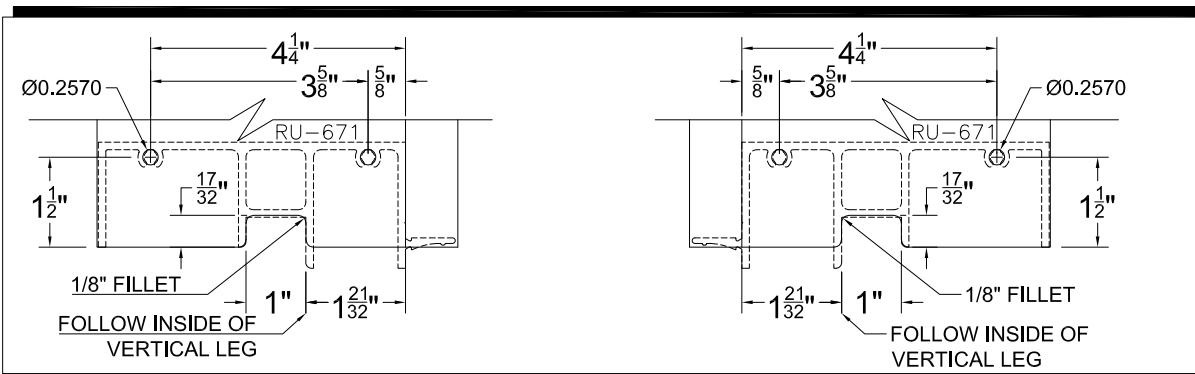
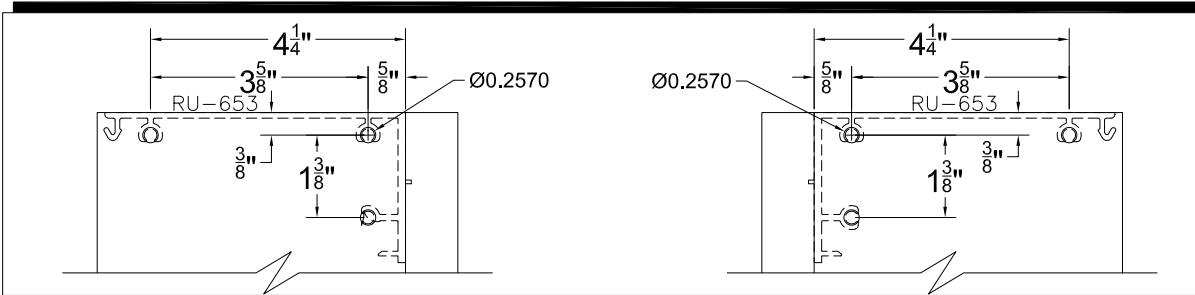
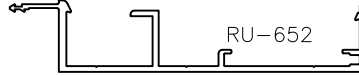
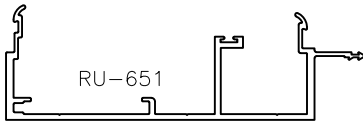

7" VERTICAL REFERENCE INFORMATION (NON CAPTURED INTERMEDIATE MULLS)

RELIANCE UNIT WALL - ASSEMBLY AND SEALING INSTRUCTIONS

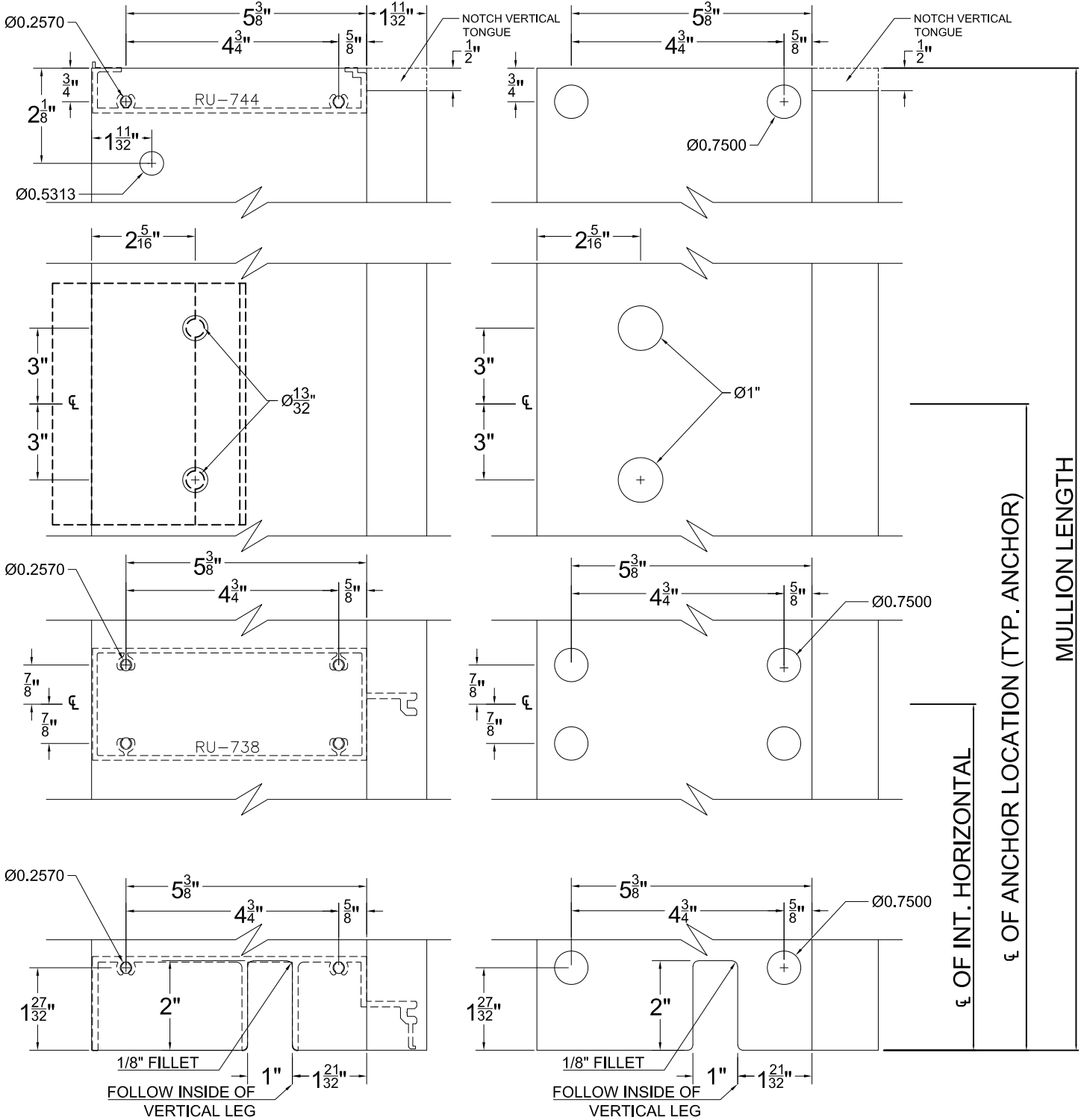
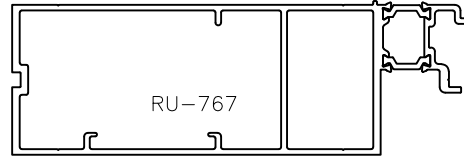
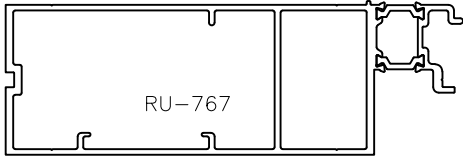

NEAR SIDE PREPS

FAR SIDE PREPS

8" VERTICAL REFERENCE INFORMATION (CAPTURED JAMB)

RELIANCE UNIT WALL - ASSEMBLY AND SEALING INSTRUCTIONS

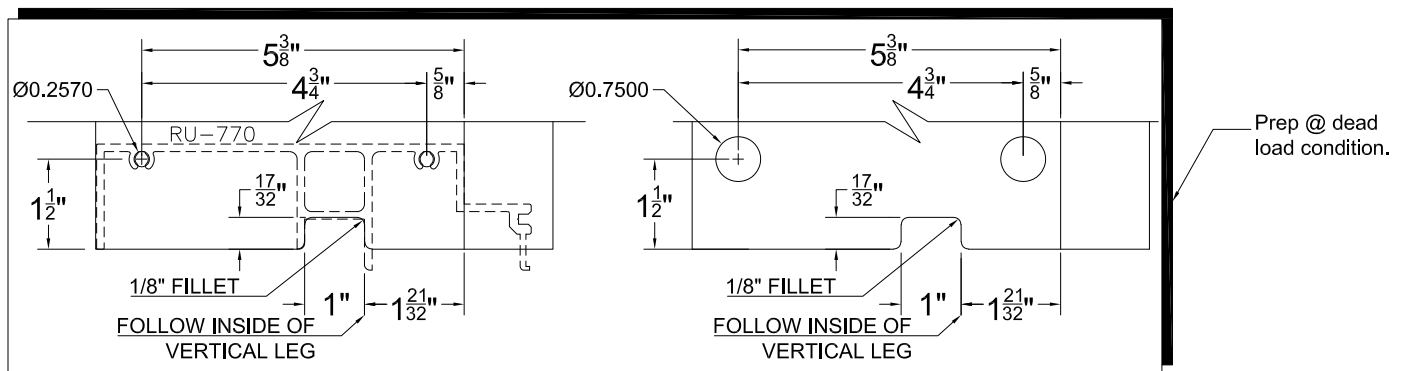
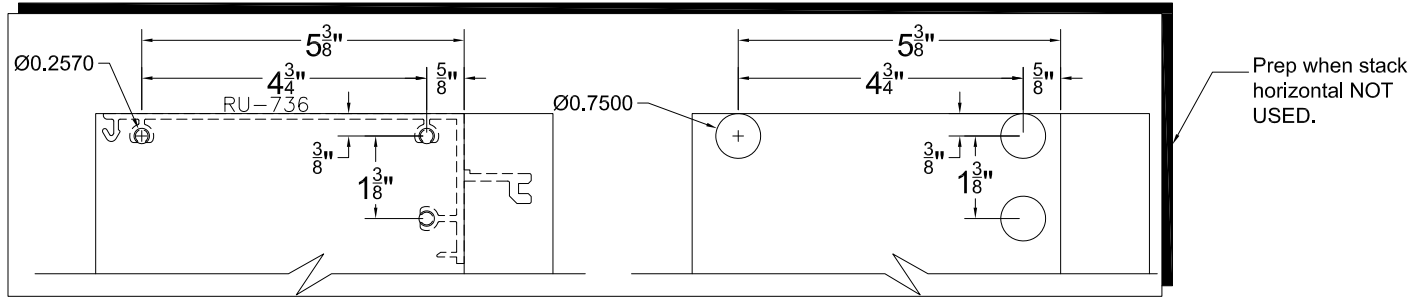
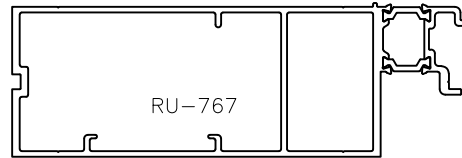
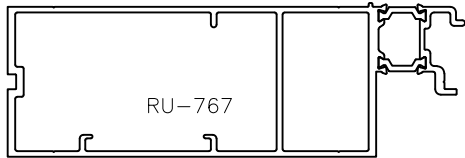

8" VERTICAL REFERENCE INFORMATION (CAPTURED JAMB)

RELIANCE UNIT WALL - ASSEMBLY AND SEALING INSTRUCTIONS

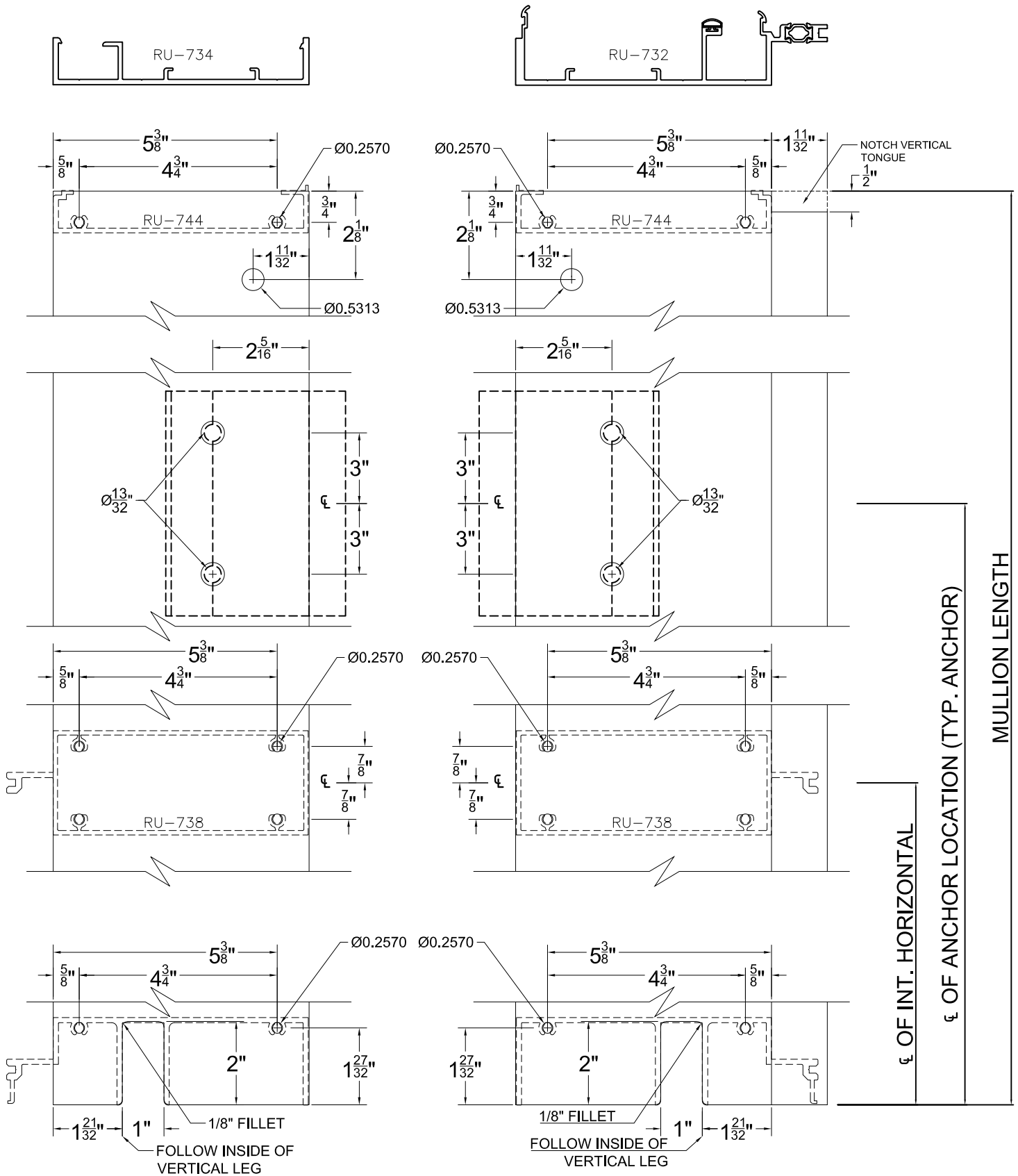

8" VERTICAL REFERENCE INFORMATION (CAPTURED INTERMEDIATE MULL)

RELIANCE UNIT WALL - ASSEMBLY AND SEALING INSTRUCTIONS

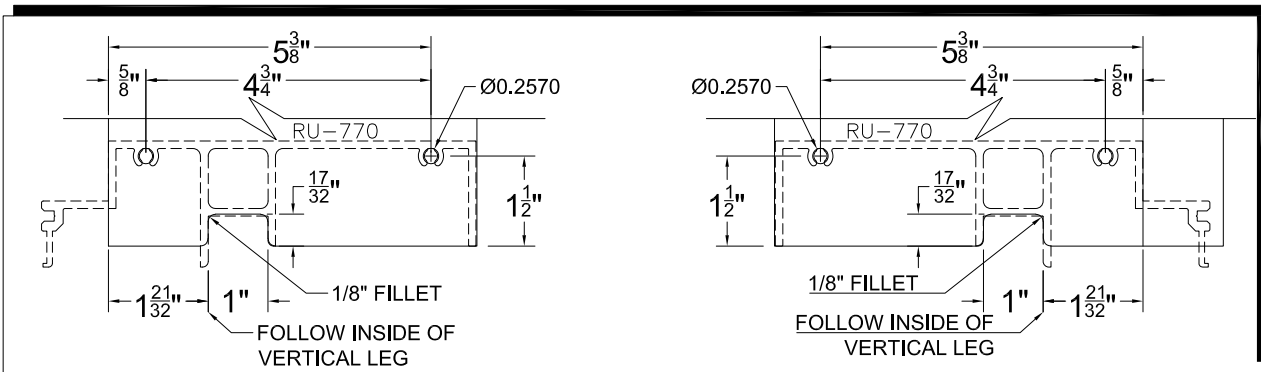
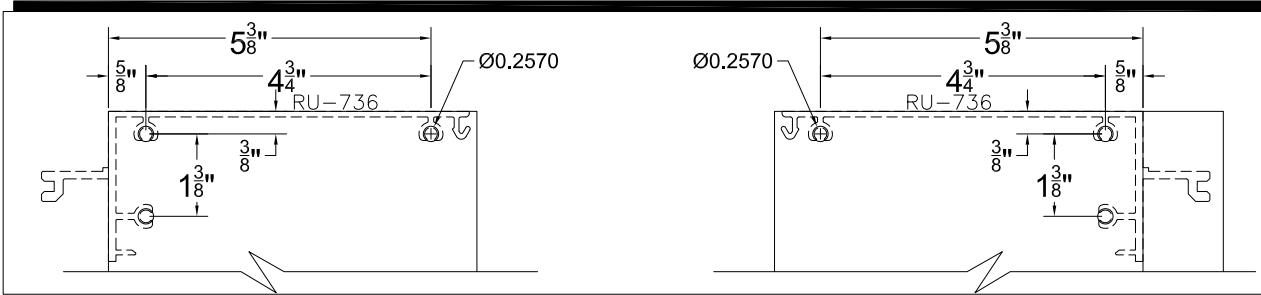
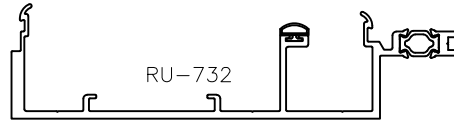

8" VERTICAL REFERENCE INFORMATION (CAPTURED INTERMEDIATE MULL)

RELIANCE UNIT WALL - ASSEMBLY AND SEALING INSTRUCTIONS

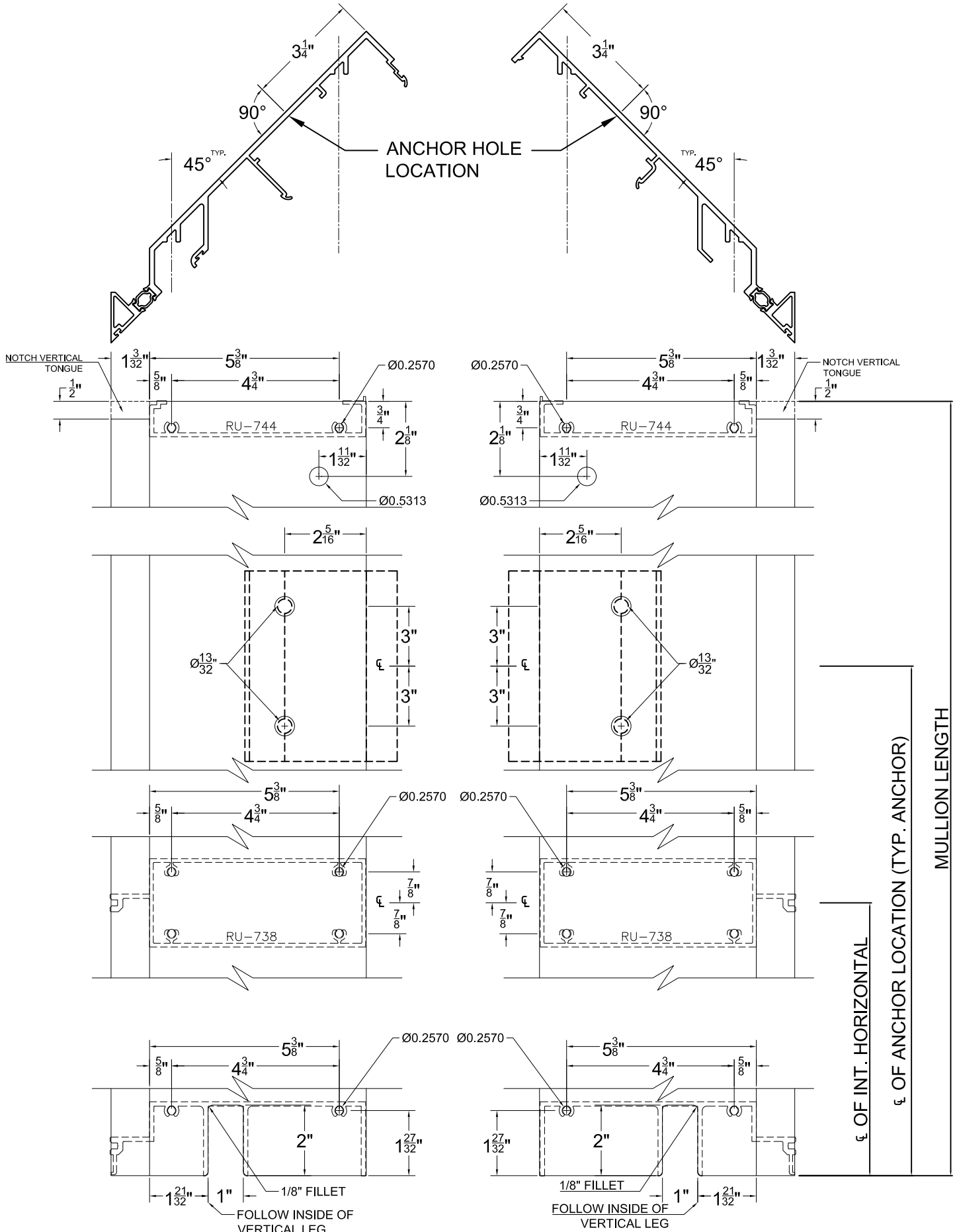

8" VERTICAL REFERENCE INFORMATION (CAPTURED O.S. 90° MULL)

RELIANCE UNIT WALL - ASSEMBLY AND SEALING INSTRUCTIONS

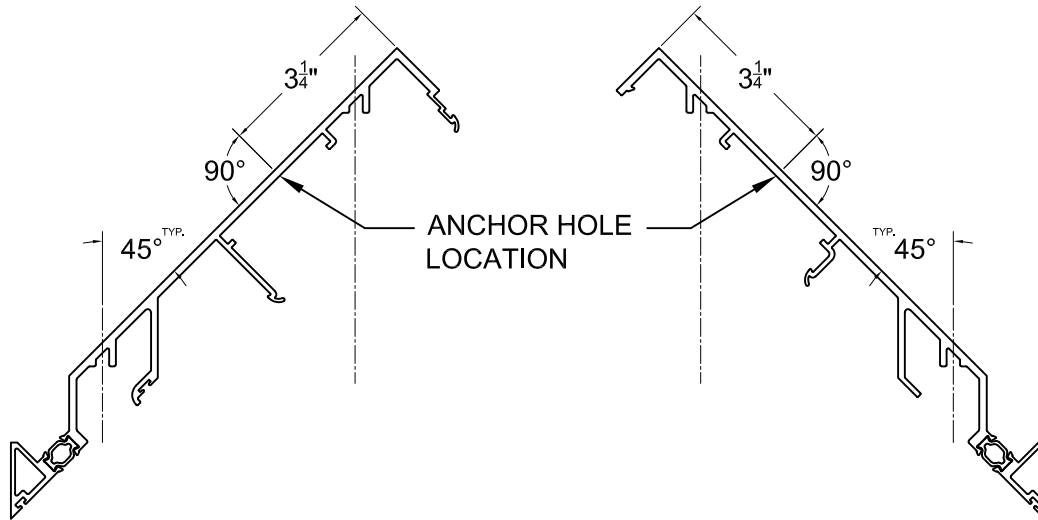

Prep when stack horizontal NOT USED.

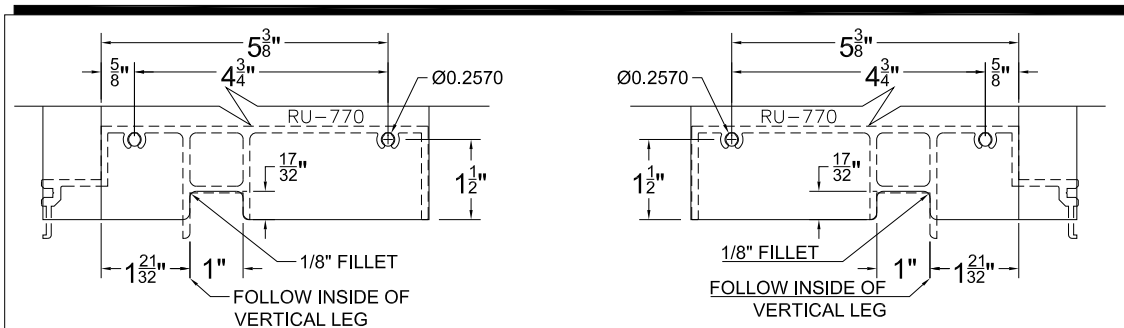

Prep @ dead load condition.

8" VERTICAL REFERENCE INFORMATION (CAPTURED O.S. 90° MULL)

RELIANCE UNIT WALL - ASSEMBLY AND SEALING INSTRUCTIONS

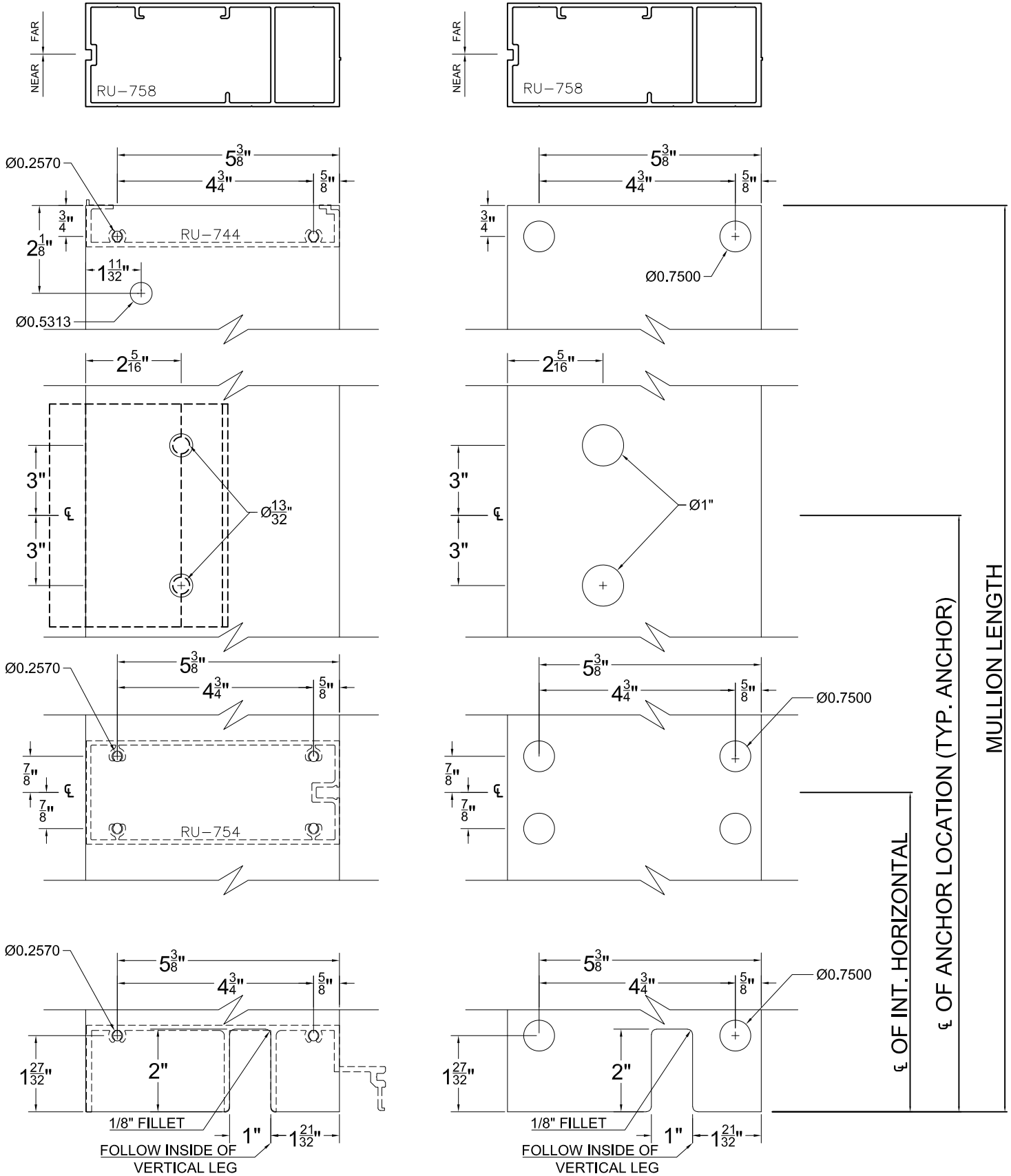

NEAR SIDE PREPS

FAR SIDE PREPS

8" VERTICAL REFERENCE INFORMATION (NON CAPTURED JAMB)

RELIANCE UNIT WALL - ASSEMBLY AND SEALING INSTRUCTIONS

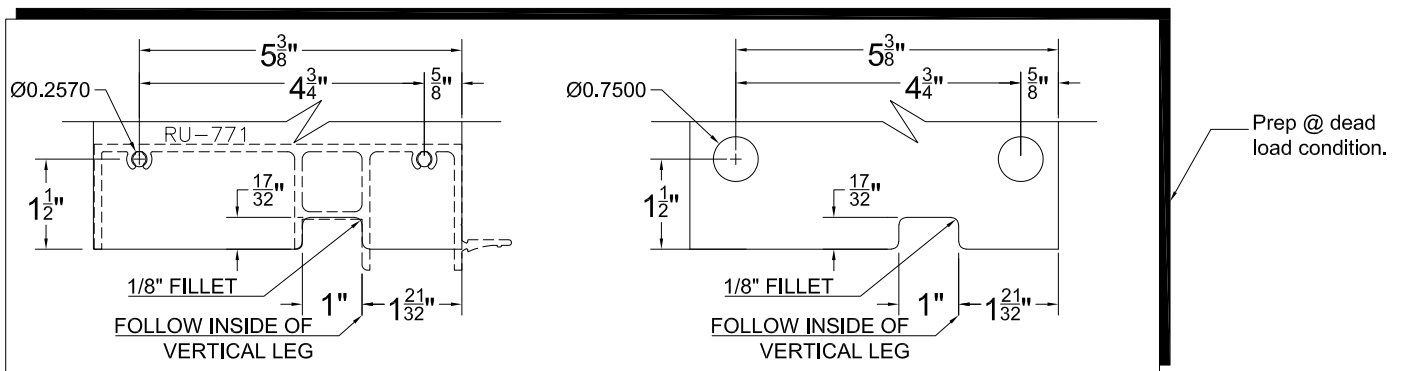
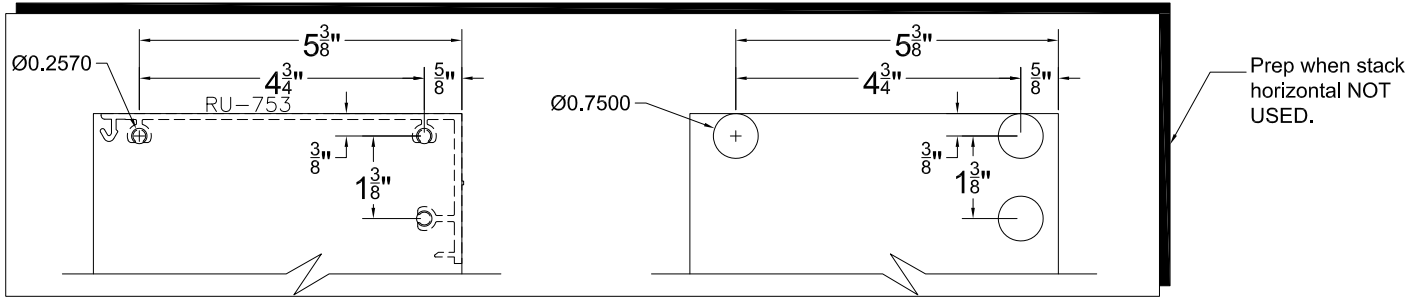
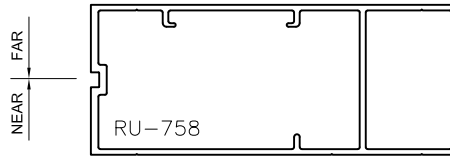
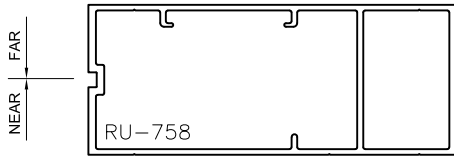

8" VERTICAL REFERENCE INFORMATION (NON CAPTURED JAMB)

RELIANCE UNIT WALL - ASSEMBLY AND SEALING INSTRUCTIONS

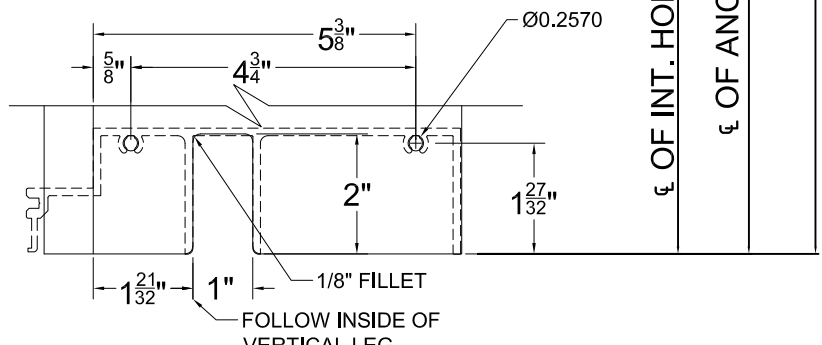
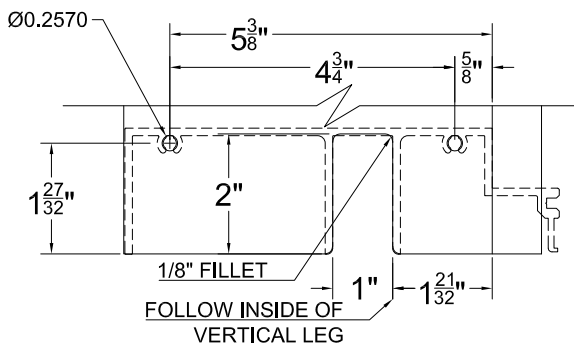
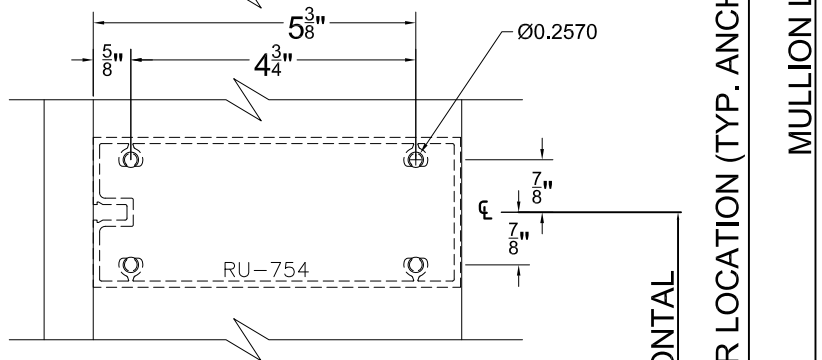
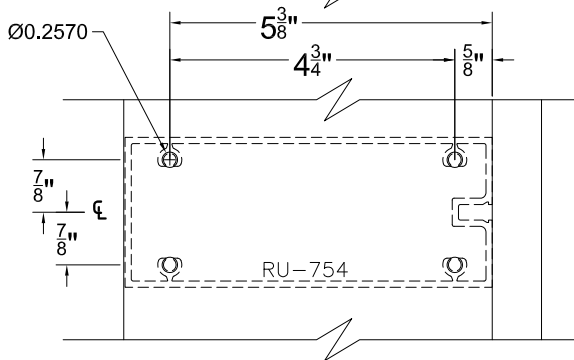
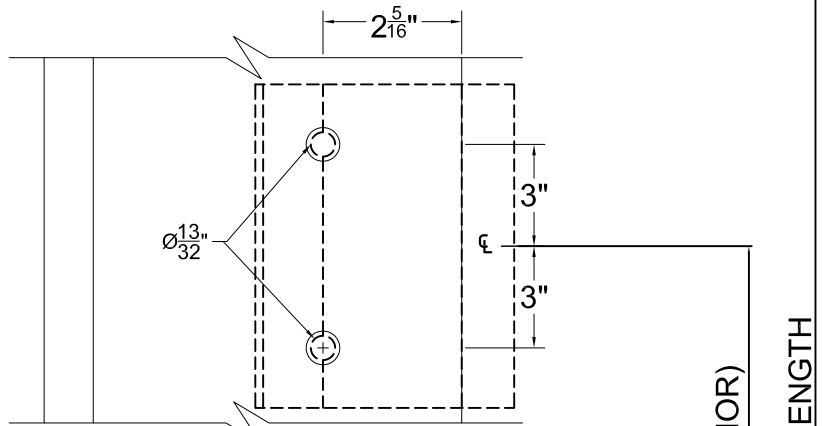
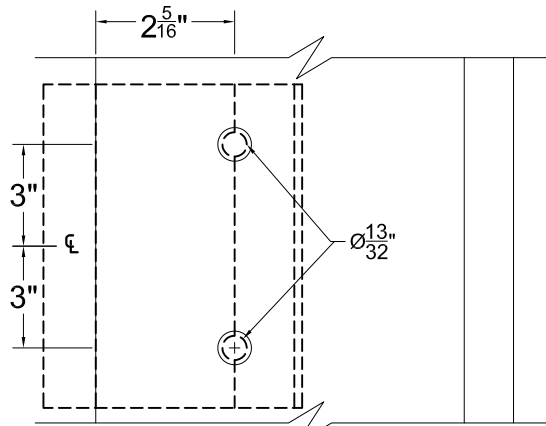
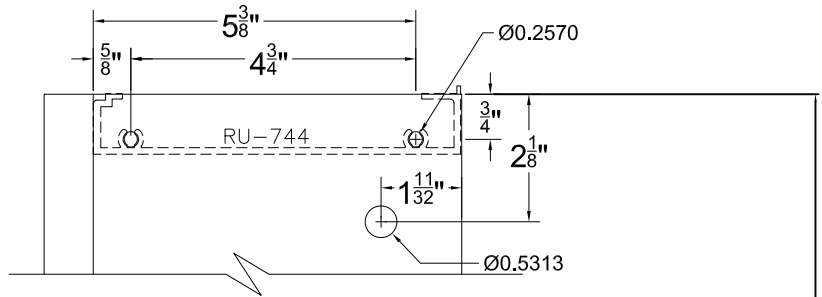
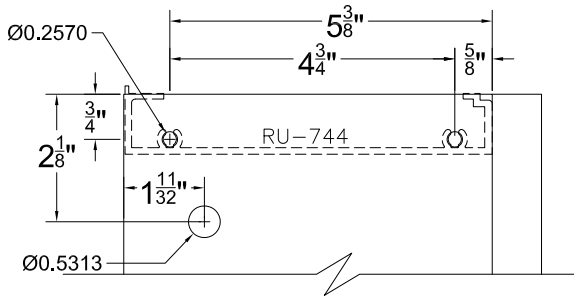
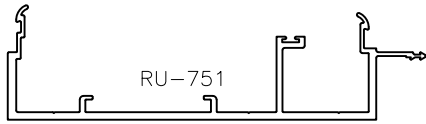

MULLION LENGTH
 ϵ OF ANCHOR LOCATION (TYP. ANCHOR)
 ϵ OF INT. HORIZONTAL

8" VERTICAL REFERENCE INFORMATION (NON CAPTURED INTERMEDIATE MULLS)

RELIANCE UNIT WALL - ASSEMBLY AND SEALING INSTRUCTIONS

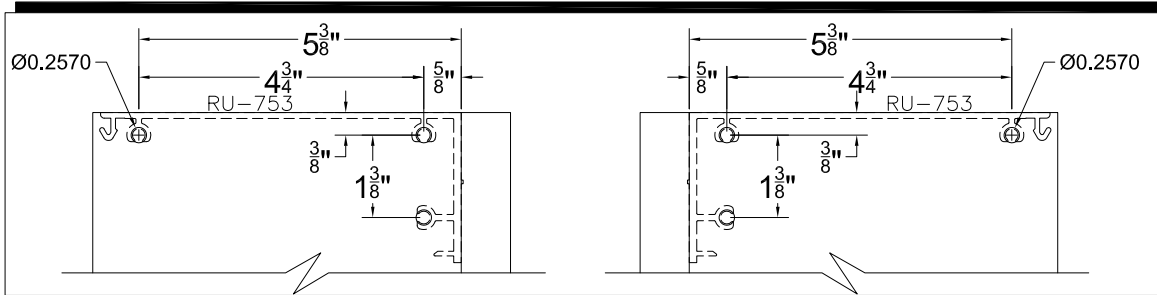
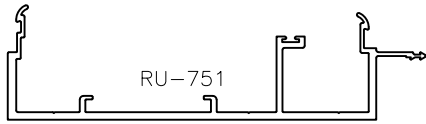

Prep when stack horizontal NOT USED.

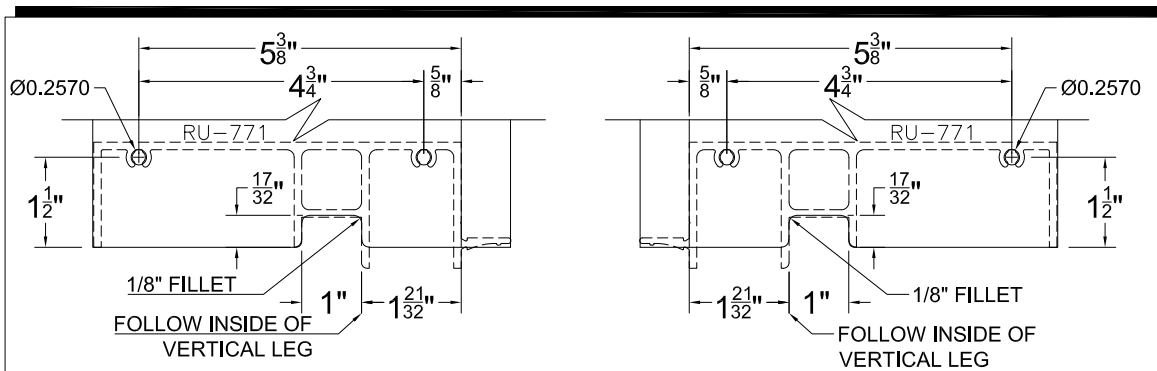

Prep @ dead load condition.

8" VERTICAL REFERENCE INFORMATION (NON CAPTURED INTERMEDIATE MULLS)

RELIANCE UNIT WALL - ASSEMBLY AND SEALING INSTRUCTIONS

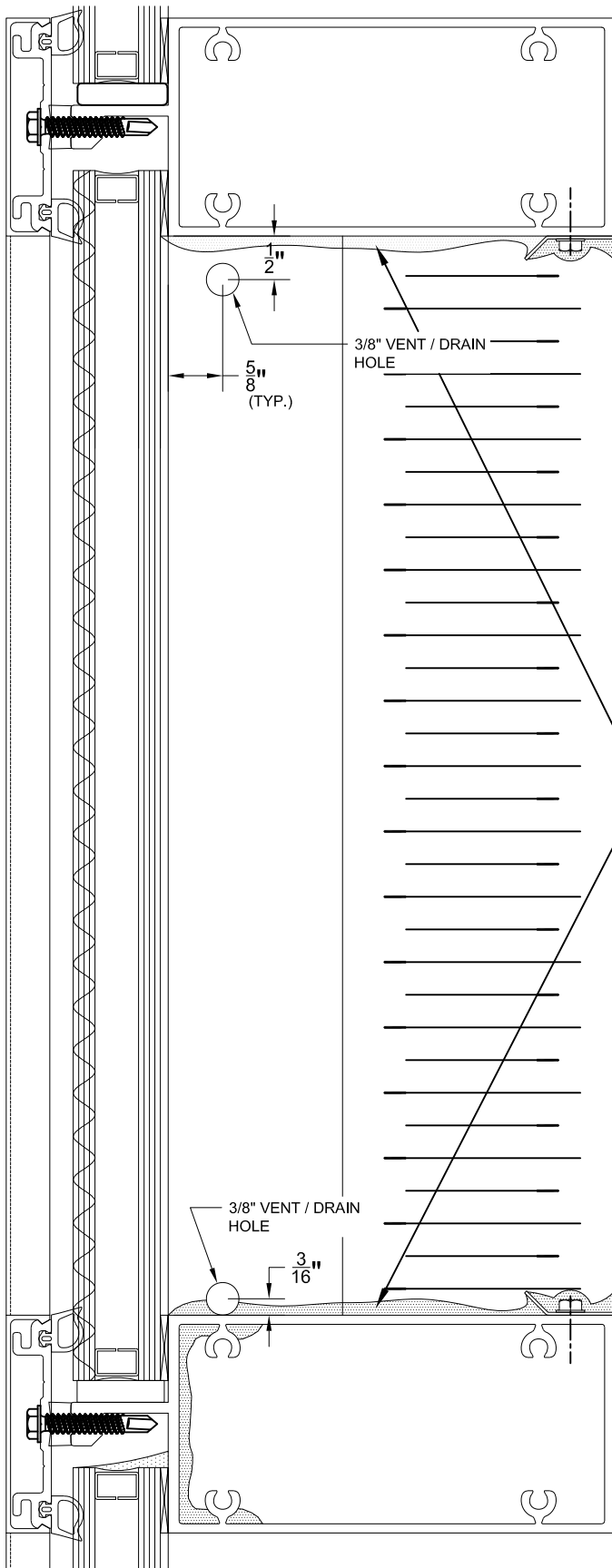

NOTE: Vent holes are designed for use with metal back pans which are hermetically sealed to glazing cavity openings on the back face. If the cavity is left open, or if FSK tape is used to seal the insulation to the framing, consideration must be given to the effect of vent holes at elevated structural loads during testing.

NOTE: Complete seal, water tight, all metal to metal joints within the spandrel cavity.

RELIANCE UNIT WALL - ASSEMBLY AND SEALING INSTRUCTIONS

1. LAYOUT PARTS

Typically units are to be assembled with Female Mullion Half on the left of the unit and with the Male Mullion Half on the right of the unit (viewed from exterior of the unit). Please refer to shop drawings for proper mullion half required at left and right jamb units.

Check that all preps have been applied and located in the proper position per approved shop drawings.

2. APPLY SILICONE SEALANT

Clean and butter top of the vertical mullions and both ends of horizontals with silicone sealant per approved shop drawings.

NOTE: ALL ASSEMBLY WORK MUST BE COMPLETED IMMEDIATELY AFTER SEALANT APPLICATION. BEFORE SEALANT SKINS.

Butter both ends of the head horizontal from the front leg continuously around the perimeter including screw chase.

CAPTURED

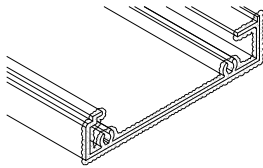

NON CAPTURED

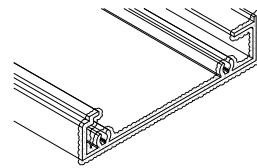

Butter both ends of the intermediate transom from the lower screw chase inboards to the upper screw chase.
(NOTE: Spandrel & shadow box cavity areas are to be sealed full depth of horizontal.)

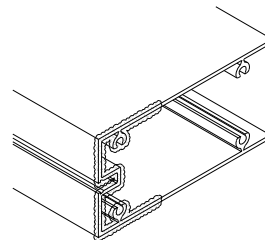
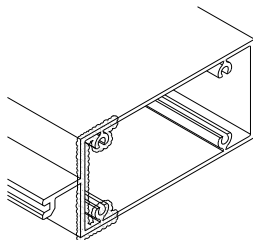

Butter both ends of the transom at the front wall up to the first screw chase.
(NOTE: Spandrel & shadow box cavity areas are to be sealed full depth of horizontal.)

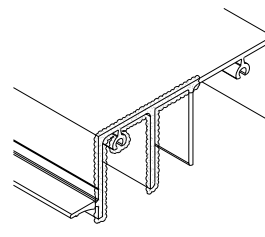
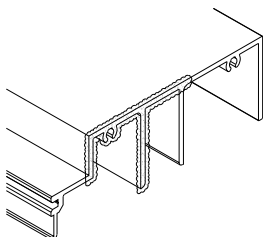

RELIANCE UNIT WALL - ASSEMBLY AND SEALING INSTRUCTIONS

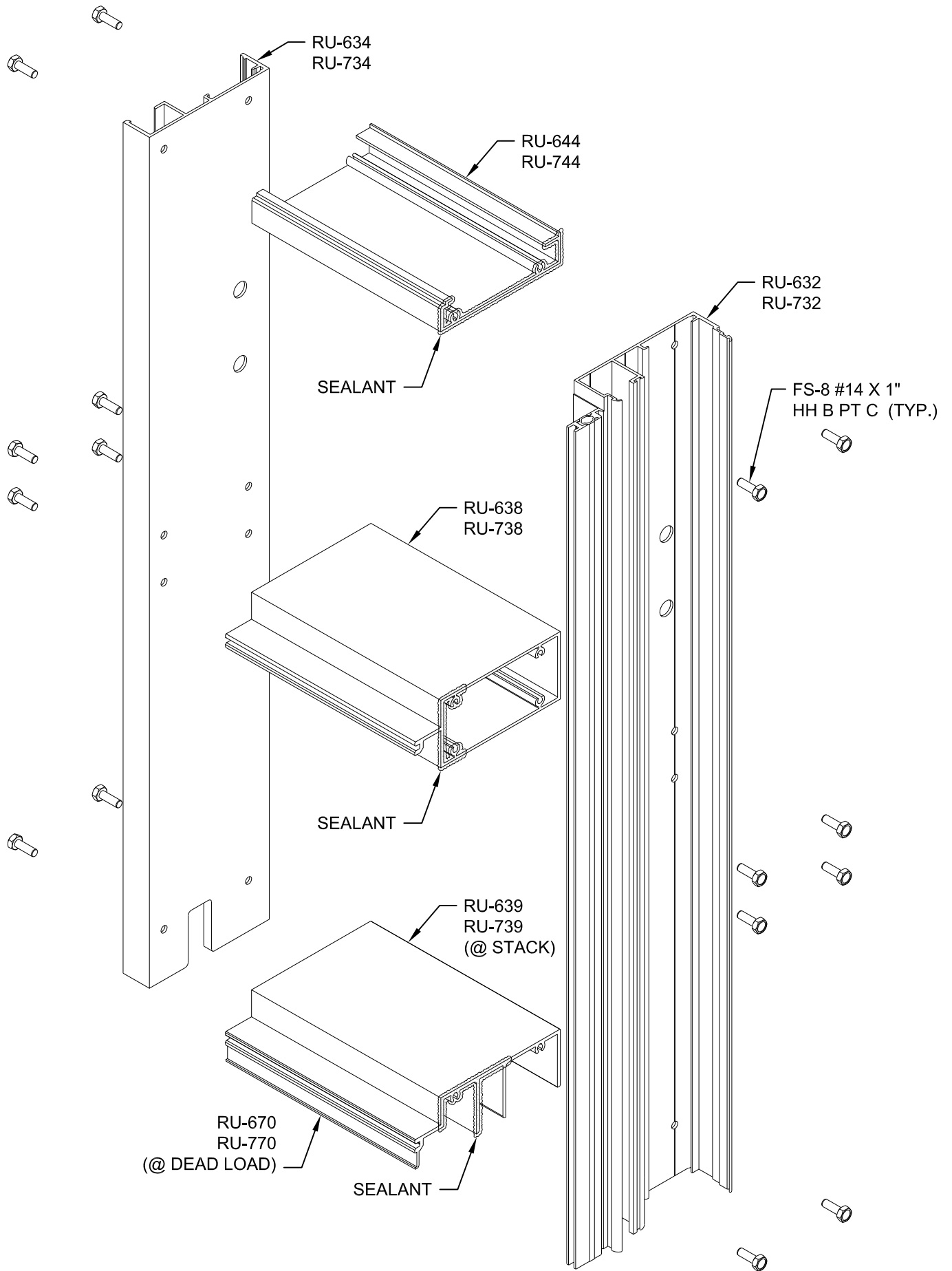

FRAME ASSEMBLY INSTRUCTIONS (CAPTURED)

RELIANCE UNIT WALL - ASSEMBLY AND SEALING INSTRUCTIONS

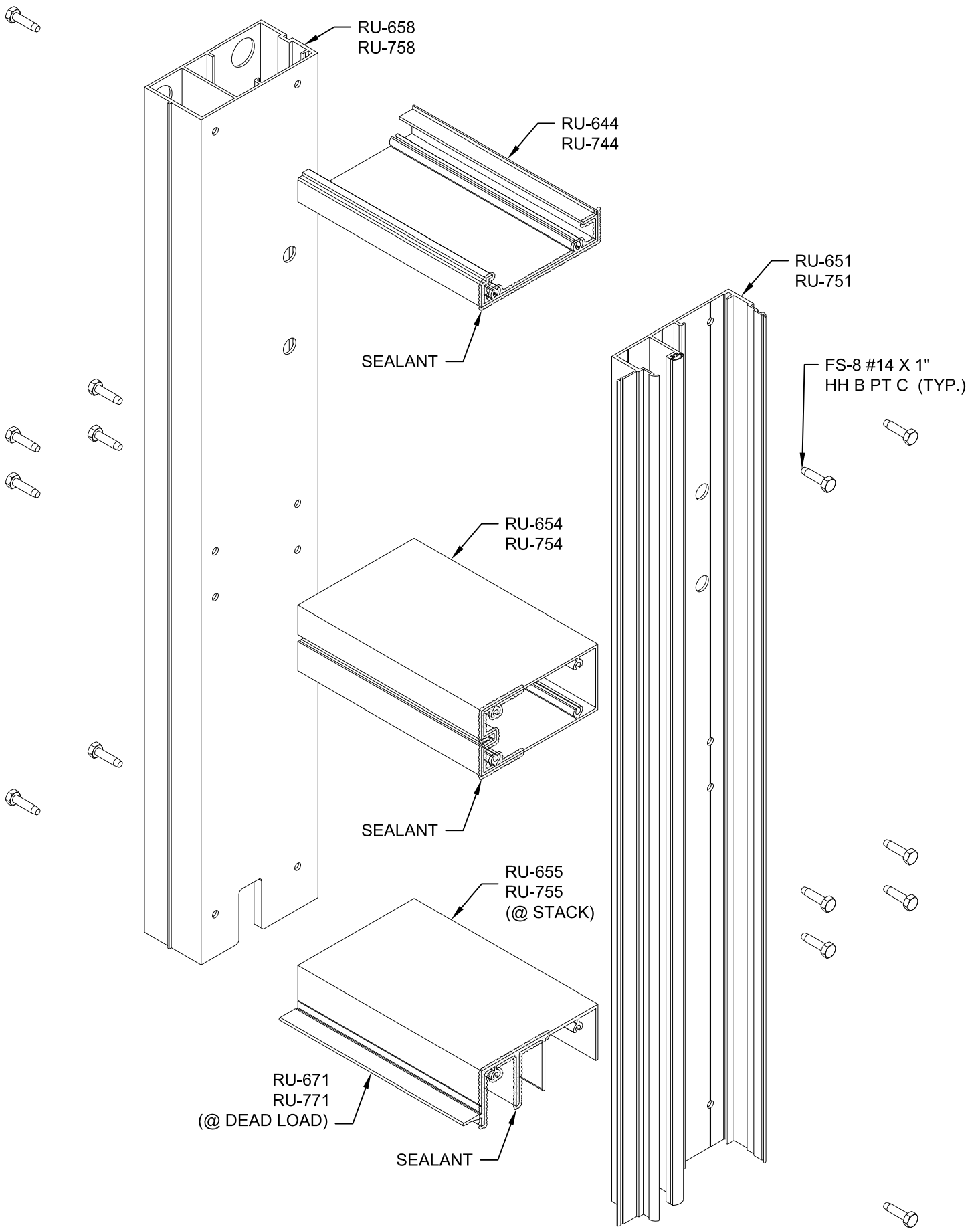

FRAME ASSEMBLY INSTRUCTIONS (NON CAPTURED)

RELIANCE UNIT WALL - ASSEMBLY AND SEALING INSTRUCTIONS

RUW-MA04 is attached using
 FS-74 1/2"-13 X 2"
 (2)FSW-73 FLAT WASHER
 FSW-71 LOCK WASHER
 FSN-69 NUT
 (1) PER LIFTING LUG

RUW-MA01 is attached using
 FS-289 .375 X 1 1/4"
 (2) FSW-80 FLAT WASHERS
 FSW-83 LOCK WASHER
 FSN-81 NUT
 (2) PER ANCHOR

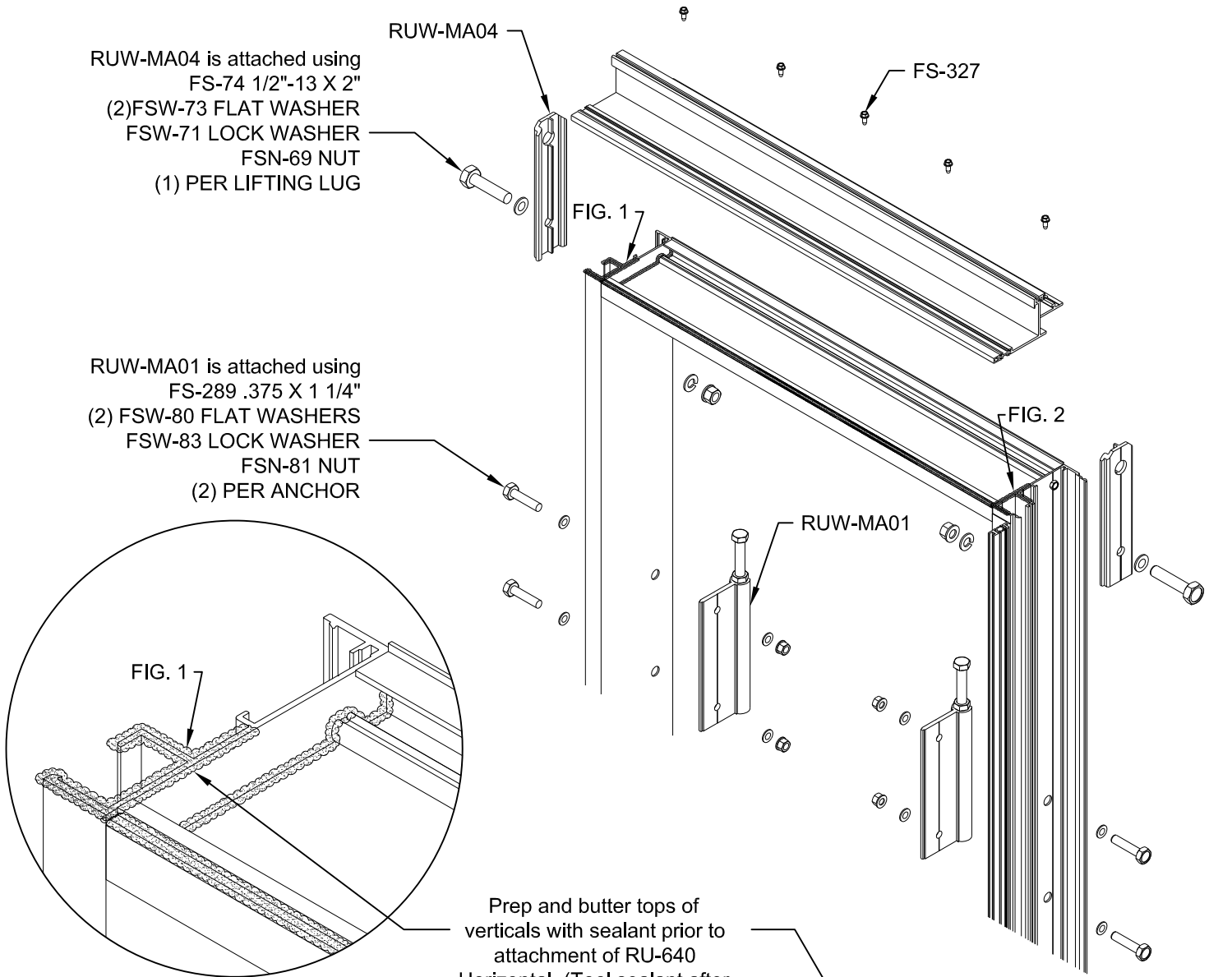

Prep and butter tops of
 verticals with sealant prior to
 attachment of RU-640
 Horizontal. (Tool sealant after
 RU-640 is installed)

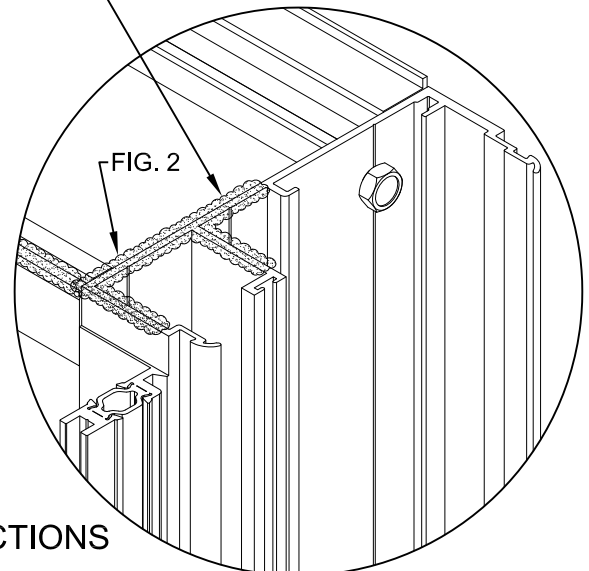
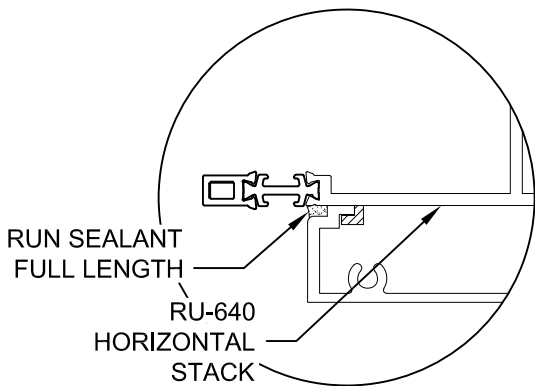

RUN SEALANT
 FULL LENGTH
 RU-640
 HORIZONTAL
 STACK

RELIANCE UNIT WALL - ASSEMBLY AND SEALING INSTRUCTIONS

ASSEMBLING FRAME

Position horizontal members aligning with splines with screw holes and assemble with FS-8 #14 x 1" long hex washer head Type B pt assembly screws.

When applying opposite side of mullion half, do not tighten screws until all horizontals have been applied to keep from wiping off the sealant with mullion during installation.

A RING OF SEALANT SHOULD APPEAR AROUND EVERY SCREW HEAD LOCATED IN WET AREAS. (SEE FIGURE BELOW)

THOROUGHLY SEAL OVER SCREW HEADS WHICH ARE LOCATED OUTSIDE OF THE AIR SEAL CHAMBER.

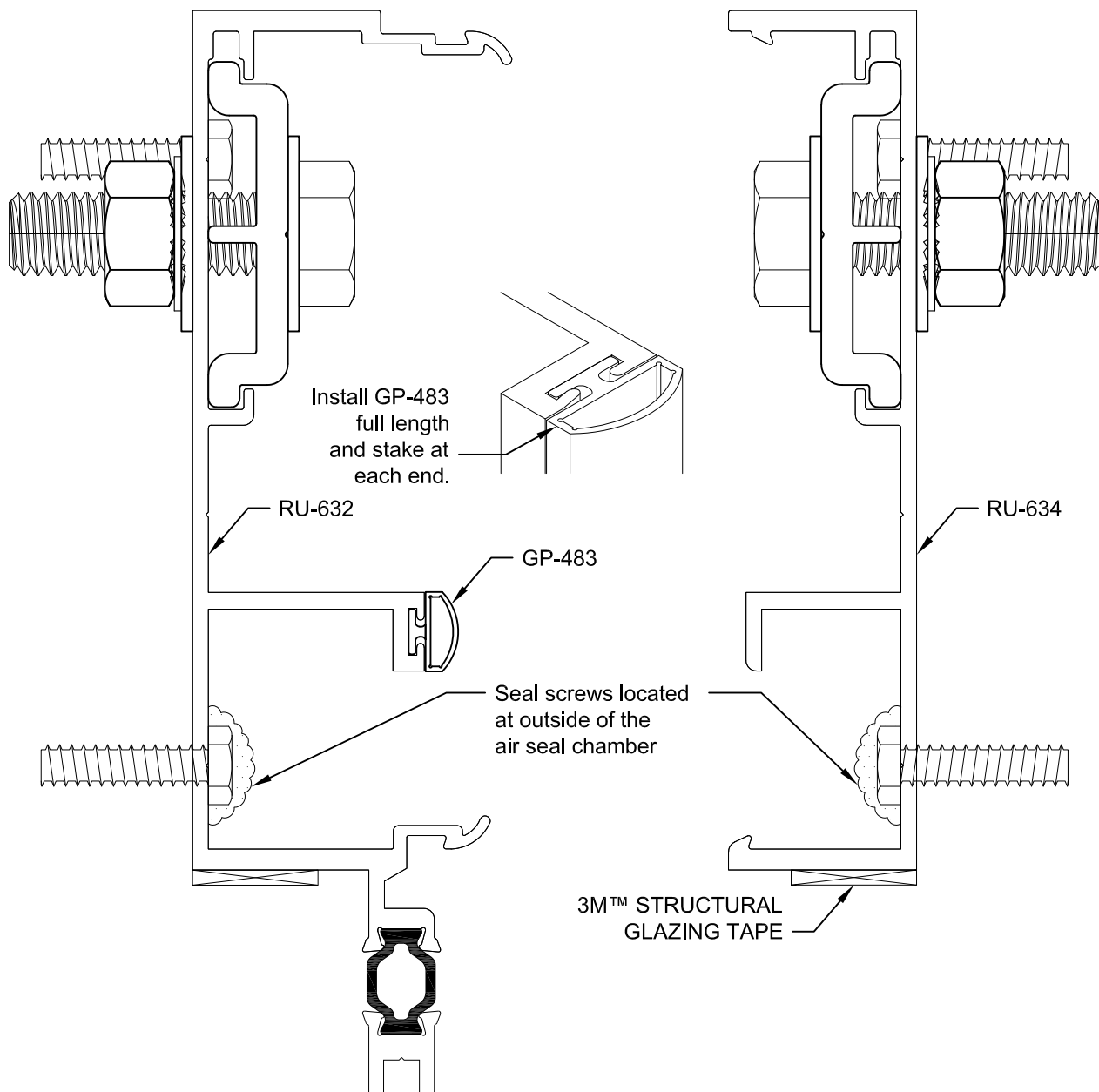

FRAME ASSEMBLY INSTRUCTIONS

RELIANCE UNIT WALL - ASSEMBLY AND SEALING INSTRUCTIONS

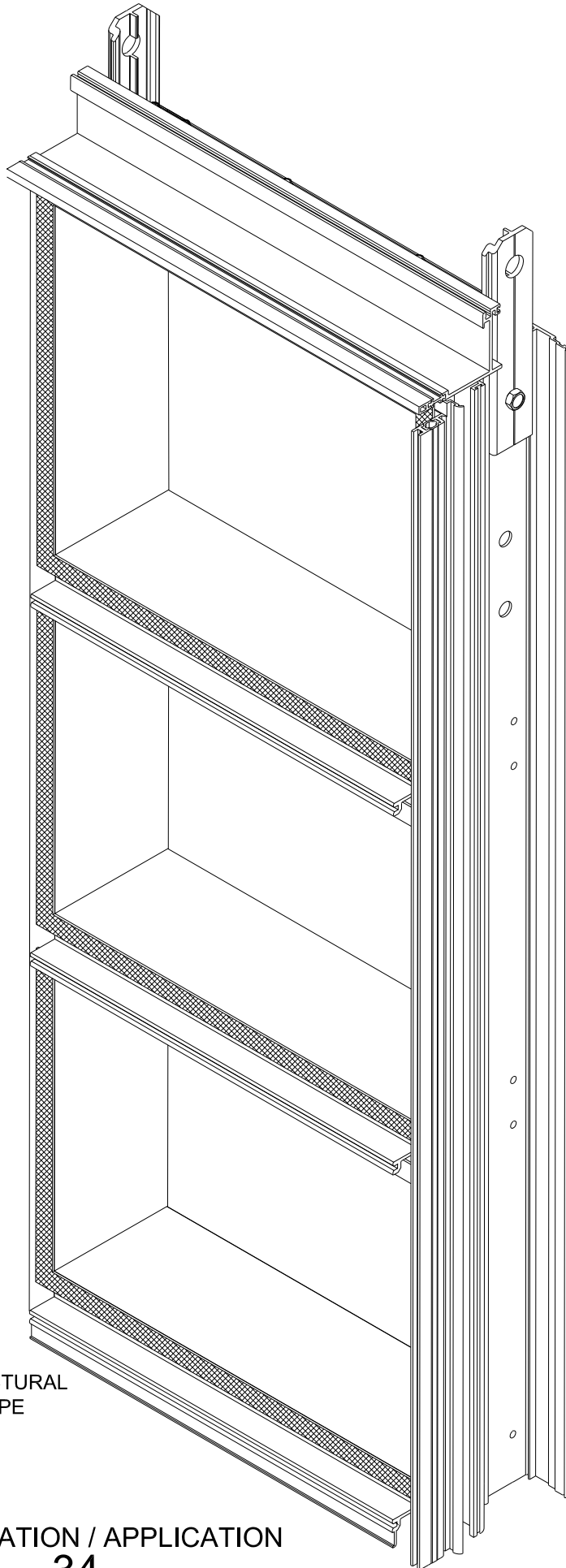
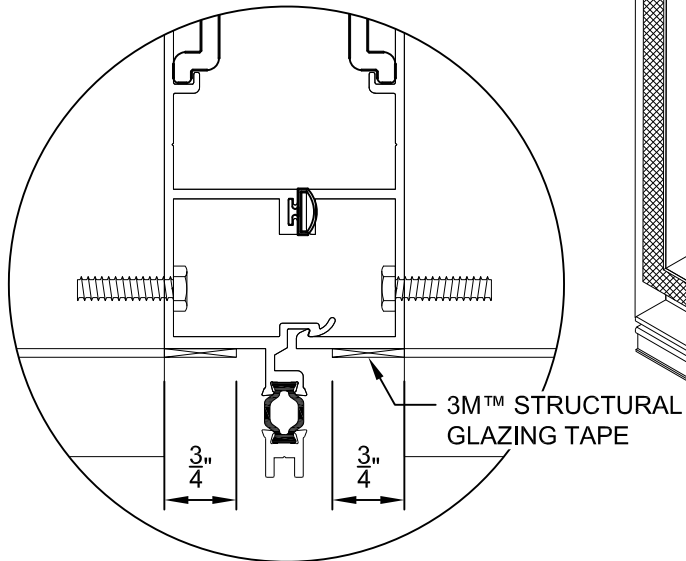
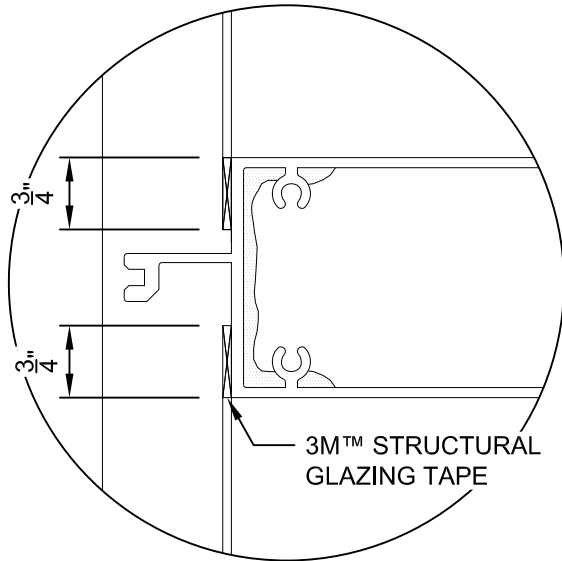
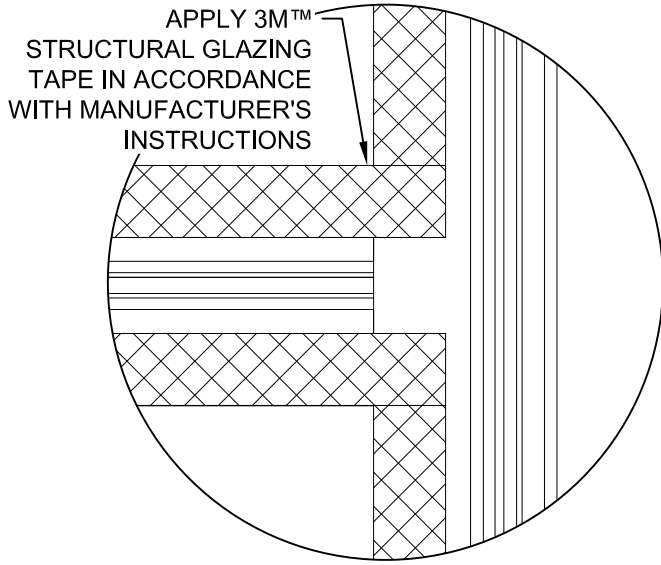

TAPE LOCATION / APPLICATION

RELIANCE UNIT WALL - ASSEMBLY AND SEALING INSTRUCTIONS

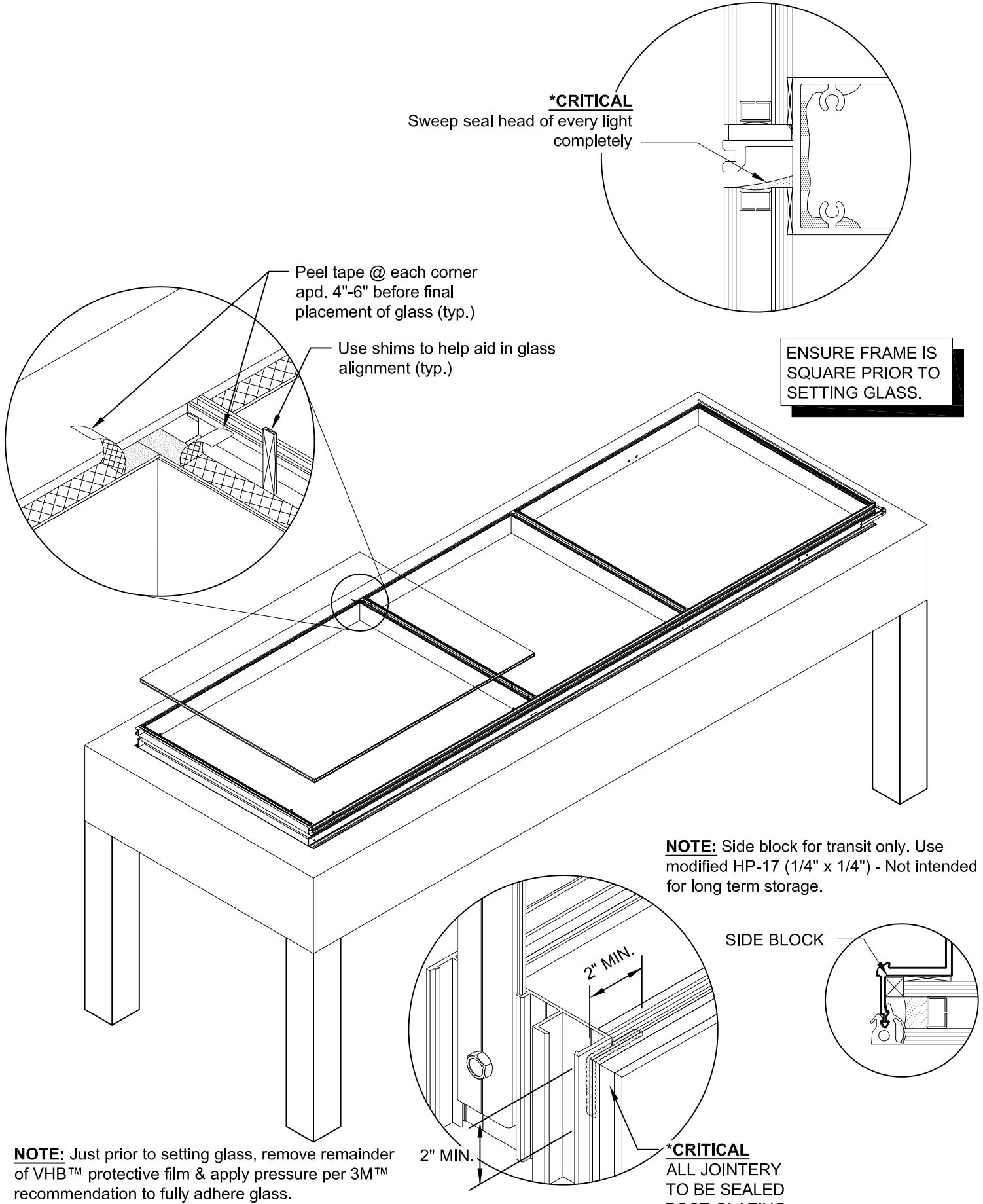

NOTE: Just prior to setting glass, remove remainder of VHB™ protective film & apply pressure per 3M™ recommendation to fully adhere glass.

NOTE: Side block for transit only. Use modified HP-17 (1/4" x 1/4") - Not intended for long term storage.

ENSURE FRAME IS SQUARE PRIOR TO SETTING GLASS.

***CRITICAL**
ALL JOINTERY TO BE SEALED POST GLAZING.

RELIANCE UNIT WALL - ASSEMBLY AND SEALING INSTRUCTIONS

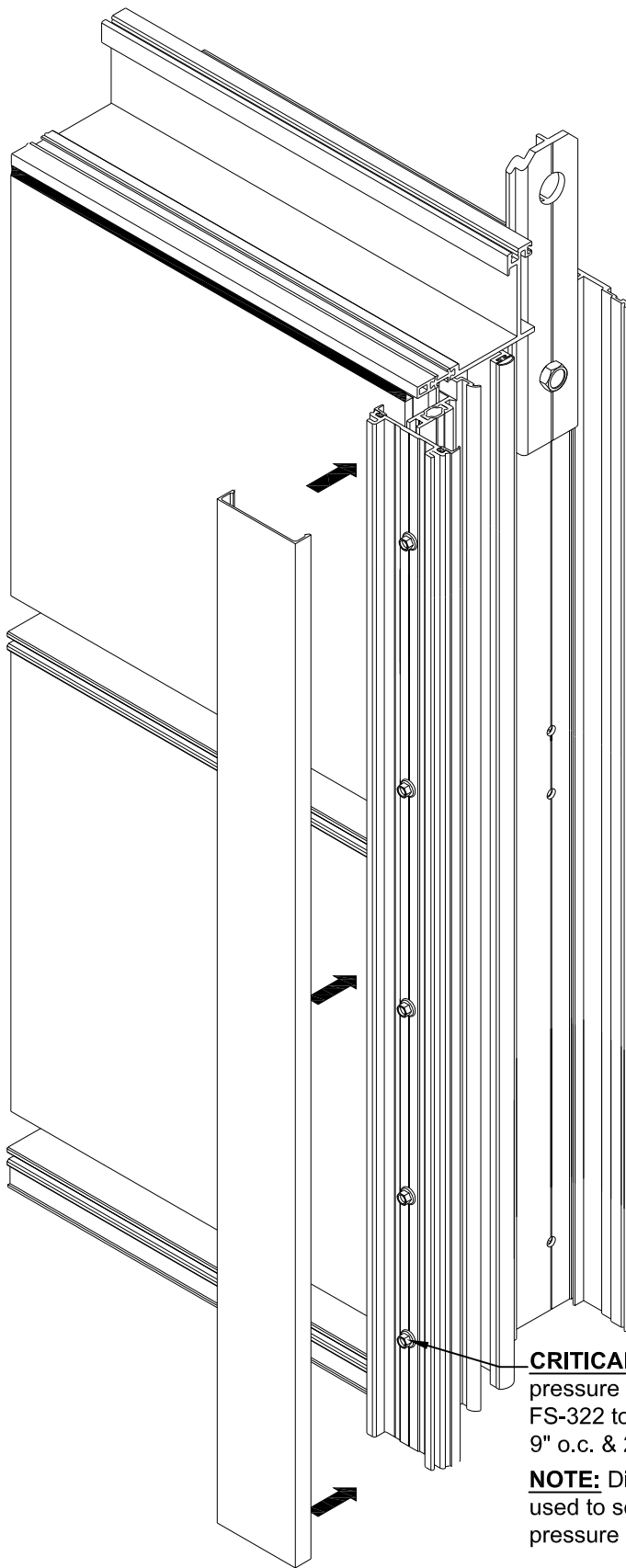

CRITICAL: Vertical pressure plate attached with FS-322 torqued to 70 in lb, 9" o.c. & 2" from each end.

NOTE: Different fastener used to secure horizontal pressure plate.

VERTICAL FACE CAP & PRESSURE PLATE LOCATING DIMENSIONS

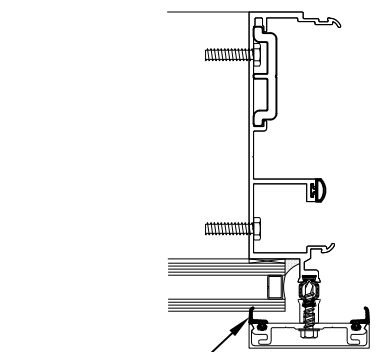
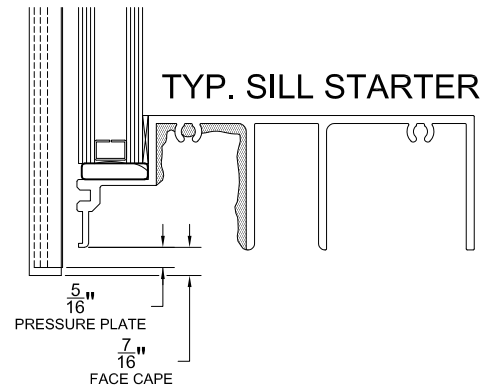
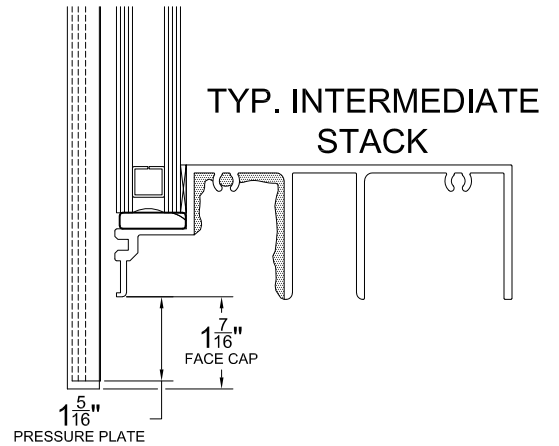

GP-50028 SWEEP GASKET (2) @ MULLION

PRESSURE PLATE INSTALLATION

RELIANCE UNIT WALL - ASSEMBLY AND SEALING INSTRUCTIONS

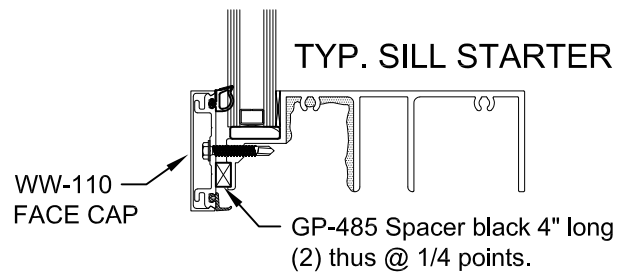
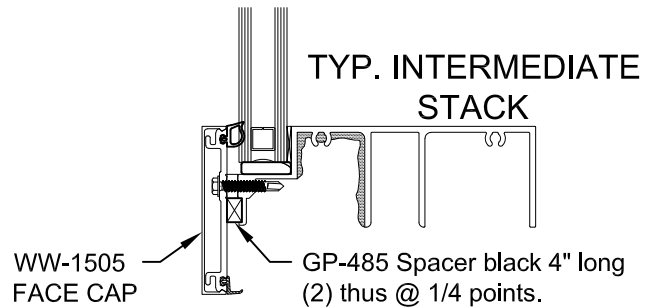
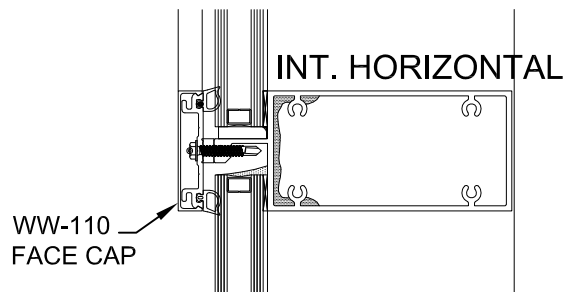
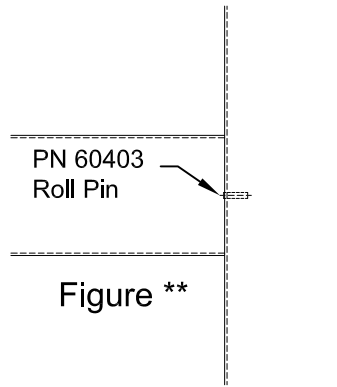
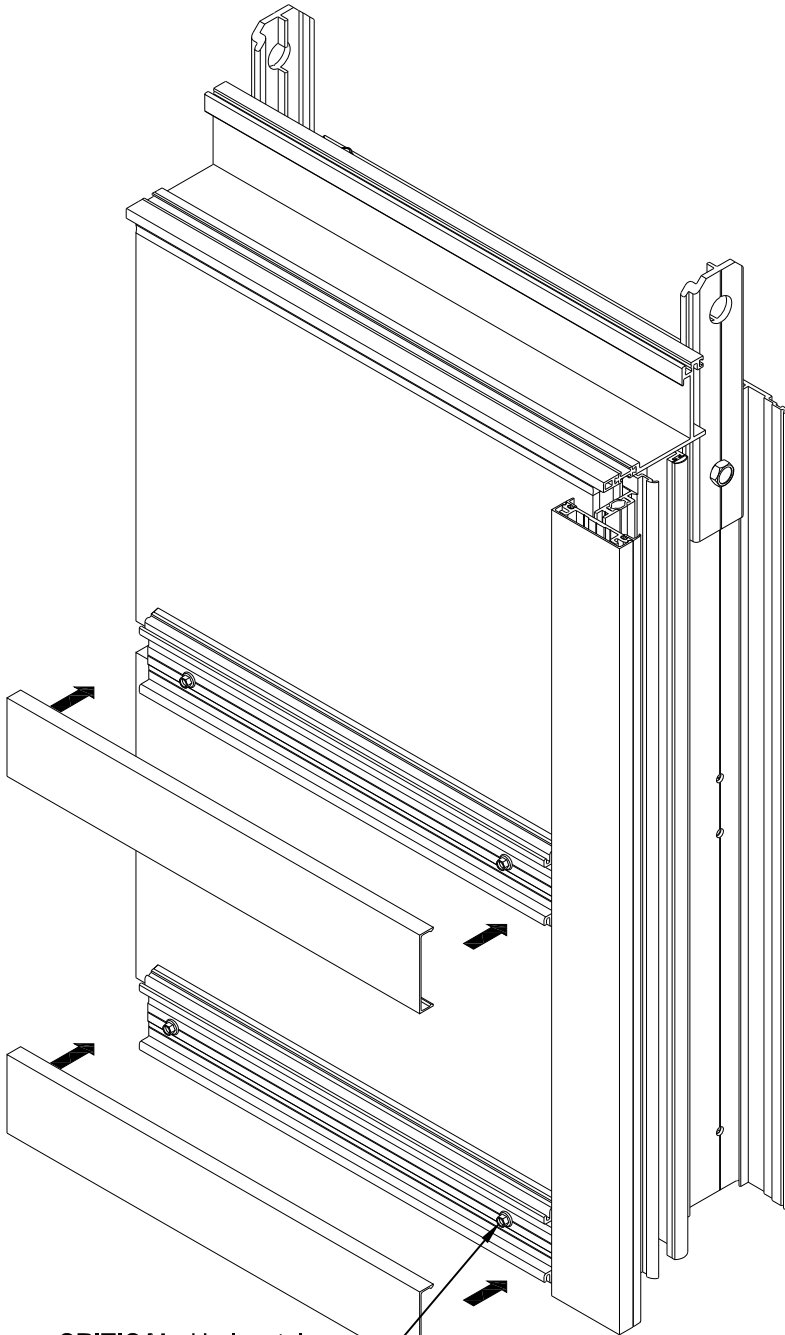

CRITICAL: Horizontal pressure plate attached with FS-325 torqued to 70 in lb, 9" o.c. & 2" from each end.

NOTE: Different fastener used to secure vertical pressure plate.



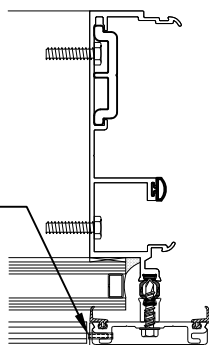





















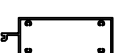



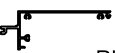





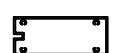





(FS-317 Pin) (1) required at vertical cap only. Location of pin to be concealed behind horizontal cap.)
See Figure **



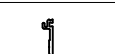

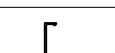

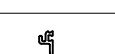

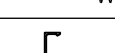
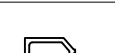































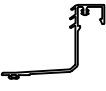
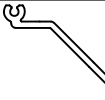



VERTICAL

HORIZONTAL FACE CAP INSTALLATION

RELIANCE UNIT WALL - ASSEMBLY AND SEALING INSTRUCTIONS

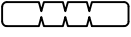
| 7" SYSTEM | | | | | |
|---|--|---|--|--|--|
|  RU-662 | Male Corner Mullion 90° Outside Captured |  RU-636 | Head Horizontal Captured |  RU-750 | Dead Load Sill Starter |
|  RU-663 | Female Corner Mullion 90° Outside Captured |  RU-673 | Sill Non Captured |  RU-749 | Stack Horizontal @ Stack Condition |
|  RU-632 | Male Mullion Captured |  RU-654 | Standard Horizontal Non Captured |  RU-744 | Head Horizontal @ Stack Condition |
|  RU-634 | Female Mullion Captured |  RU-670 | Dead Load Sill, Captured |  RU-739 | Sill, Captured |
|  RU-667 | Jamb Captured |  RU-671 | Dead Load Sill, Non Captured |  RU-738 | Standard Horizontal Captured |
|  RU-658 | Jamb Non Captured | 8" SYSTEM | | | |
|  RU-651 | Male Mullion Non Captured |  RU-762 | Male Corner Mullion 90° Outside Captured |  RU-736 | Head Horizontal Captured |
|  RU-652 | Female Mullion Non Captured |  RU-763 | Female Corner Mullion 90° Outside Captured |  RU-773 | Sill Non Captured |
|  RU-653 | Head Horizontal Non Captured |  RU-732 | Male Mullion Captured |  RU-754 | Standard Horizontal Non Captured |
|  RU-637 | Filler Trim for Head Horizontal |  RU-734 | Female Mullion Captured |  RU-770 | Dead Load Sill, Captured |
|  RU-650 | Dead Load Sill Starter |  RU-767 | Jamb Captured |  RU-771 | Dead Load Sill, Non Captured |
|  RU-649 | Stack Horizontal @ Stack Condition |  RU-758 | Jamb Non Captured | COMMON EXTRUSIONS | |
|  RU-644 | Head Horizontal @ Stack Condition |  RU-751 | Male Mullion Non Captured |  RU-642 | Pressure Plate for 3 1/2" Face Cap @ Stack, Captured |
|  RU-639 | Sill 1" Infill, Captured |  RU-752 | Female Mullion Non Captured |  WW-1505 | 3 1/2" Face Cap @ Stack Condition, Captured |
|  RU-638 | Standard Horizontal Captured |  RU-753 | Head Horizontal Non Captured |  WW-162 | Pressure Plate for 2 1/2" Face Cap (Typ.), Captured |
| | |  RU-737 | Filler Trim for Head Horizontal |  WW-110 | 2 1/2" Face Cap @ Typical Condition, Captured |
| | | | |  RU-641 | Pocket Filler, Captured |

RELIANCE UNIT WALL - ASSEMBLY AND SEALING INSTRUCTIONS

| | | | | | |
|---|--|---|---|--|--------------------------------------|
|  RU-657 | Perimeter Filler, Non Captured |  FS-346 | Taplock Threaded Insert 3/8"-16x11/16" |  UCW-387 | Anchor Lug Typical |
|  SPW-1482 | Perimeter Filler Cap, Non Captured |  FS-317 | Attachment Pin |  RU-668 | 7" Mullion Anchor Typical |
|  RU-230 | Pressure Plate for 90° Corner Face Cap Captured |  UW-465 | Silicone Splice 4" |  UCW-20050 | 7" Mullion Anchor 90° O.S. Corner |
|  RU-231 | Face Cap for 90° Corner Condition Captured |  UW-466 | Silicone Splice 2" |  UCW-309 | Anchor Plate Typical |
| ACCESSORIES | | | | | |
|  FS-289 | Hex Head Bolt 3/8" X 1 1/4" |  GP-492 | Formed Silicone Boot for Sealing of 90° O.S. Corner |  UCW-200 | Serrated Anchor Plate Washer |
|  FSW-80 | Flat Washer For 3/8" Bolt |  GP-483 | Santoprene Weather Gasket |  UCW-6006 | Lifting Lug Typical |
|  FSN-81 | Nut For 3/8" Bolt |  GP-142 | EPDM Isolator |  UCW-6012 | Lifting Lug 90° O.S. Corner |
|  FS-74 | Hex Head Bolt 1/2"-13 X 2" |  GP-50008 | EPDM / Silicone Gasket |  RU-647 | Dead Load Block |
|  FSW-73 | Flat Washer For 1/2" Bolt |  GP-50028 | EPDM / Silicone Weatherseal Gasket |  RU-768 | 8" Mullion Anchor Typical |
|  FSW-71 | Lock Washer For 1/2" Bolt |  GP-185 | Air Seal Gasket @ Stack |  RU-237 | 8" Mullion Anchor 90° O.S. Corner |
|  FSN-69 | Nut For 1/2"-13 Bolt |  GP-186 | Air Seal Gasket @ Sill |  RU-201 | 7" Sill Shear Angle |
|  FS-8 | Typical Assembly Fastener |  GP-484 | 1" X 1/4" Setting Block |  RU-204 | 8" Sill Shear Angle |
|  FS-322 | Vertical Pressure Plate, Pocket Filler / Chicken Head Fastener |  GP-485 | 5/16" X 1/2" Spacer Block |  RU-645 | Stack Shear Angle |
|  FS-325 | Horizontal Pressure Plate Fastener |  HP-17 | Edge Block Modified as Needed | | |
|  FS-347 | Adjustment Bolt 3/8"-16x5" Square Head Cup Point Bolt |  3M™ VHB™ SGT | 3M Structural Glazing Tape (NOT Provided by O.B.E.) | | |
| | |  UCW-8759 | Serrated Washer | | |