

# SERIES 5900

## OUTSIDE GLAZED CURTAIN WALL

### INSTALLATION INSTRUCTIONS



Part NO. Y350

APRIL 12, 2019

WHERE WINDOWS ARE JUST THE BEGINNING®



## **TABLE OF CONTENTS**

<u>SECTION</u>	<u>PAGE</u>
I. General Notes & Guidelines .....	3-4
II. Perimeter Application .....	5-6
III. Anchor Installation .....	7
IV. Frame Assembly .....	8
V. Vertical Splice Joints .....	9
VI. Joint Plug Application .....	10-11
VII. Glazing Adaptors / Mullion Gaskets .....	12
VIII. Setting Blocks / Anti-Walk Blocks / Pressure Plate Gaskets .....	13
IX. Pressure Plate Attachment .....	14
X. Exterior Cover Installation .....	15
XI. Steel Reinforcement .....	16

### **Minimizing Condensation**

Note: Please reference EFCO's "Understanding Condensation" brochure which can be obtained through your EFCO representative.

Condensation will form on any surface when unfavorable conditions (interior temperature and relative humidity and exterior temperature) are present. When the formation of excessive condensation is a concern, it is highly recommended that a design professional is utilized to perform an analysis of the shop drawings to recommend the best possible installation methods. Please contact your EFCO representative for information on EFCO's Thermal Analysis Services.

Many current installation practices lead to an increase in the possibility of the formation of condensation. Though not all inclusive, the list of examples below illustrates conditions under which condensation is likely to occur:

1. Bridging system thermal break with non-thermally broken metal flashing or lintels that are exposed to the exterior
2. System exposure to cold air cavities
3. Interior relative humidity levels not maintained at recommended levels, see EFCO's "Understanding Condensation" brochure
4. Inadequate separation between system and surrounding condition at perimeter
5. Product combinations during the shop drawing stage that result in bridging thermal breaks of one or all products involved

## **Section I: General Notes & Guidelines**

- I. HANDLING / STORING / PROTECTING ALUMINUM** - The following precautions are recommended to assure early acceptance of your products and workmanship.
- A. HANDLE CAREFULLY** - Store with adequate separation between components so the material will not rub together. Store material off the ground. Protect materials against weather elements and other construction trades.
  - B. KEEP MATERIAL AWAY FROM WATER, MUD, AND SPRAY** - Prevent cement, plaster, and other materials from contacting with and damaging the finish. Do not allow moisture to be trapped between the finished surface and the wrapping material.
  - C. PROTECT MATERIALS AFTER ERECTION** - Wrap or erect screens with plastic sheeting over material. Cement, plaster, terrazzo, and other alkaline materials are very harmful to the finish and are to be removed with soap and water before hardening. Under no circumstances should these materials be allowed to dry or permanent staining will occur.
- II. GENERAL GUIDELINES** - The following practices are recommended for all installations:
- A. REVIEW APPROVED SHOP DRAWINGS** – Become thoroughly familiar with the project. Shop drawings govern when conflicting information exists in these installation instructions.
  - B. INSTALL ALL FRAMING MATERIAL PLUMB, LEVEL, AND TRUE** – Proper alignment and relationships to benchmarks and column centerlines, as established by the architectural drawings and the general contractor, must be maintained.
  - C.** The sequence of erection should be coordinated with the project superintendent to prevent delays and minimize the risk of material damage.  
**Note: If preset anchors are required, coordinate and supervise anchor placement with the general contractor.**
  - D.** Verify that all job site conditions and accompanying substrates receiving the installation are in accordance with the contract documents. If deviations occur, notification must be given **IN WRITING** to the general contractor and differences resolved before proceeding further with the installation in the questionable area.
  - E.** Prevent all aluminum from coming in direct contact with masonry or dissimilar materials by means of an appropriate primer.

## **Section I: General Notes & Guidelines**

- F.** Follow EFCO framing installation and glazing instructions.
- G.** Verify contents of all material shipments received upon arrival. Verify quantity and correct finishes. **NOTIFY EFCO IMMEDIATELY OF ANY DISCREPANCIES OR DAMAGE, THAT MAY HAVE OCCURRED.**
- H.** Throughout these instructions the term "**SEALANT**" will appear. For the purposes of these instructions, sealant is to be defined as the following:

SEALANT - A weather resistant, gunnable liquid filler which when cured provides a resilient, flexible ( $\pm 50\%$  movement capability) air and water seal between similar and dissimilar materials.

All sealant must meet **ASTM C 920, CLASS 50.**

**BUTYL SEALANT-** A non-skinning, non-hardening material (**NAAMM Reference Standard 5C-1**)

**NOTE:** All sealant must be compatible with all surfaces where adhesion is required, including other sealant surfaces. All frame surfaces should be clean, dry, dust, and frost free. If a primer is required, it must be applied to clean surfaces. All perimeter substrates shall be clean and properly treated to receive sealant.

This system is designed and has been tested to utilize butyl or silicone sealants at all internal joineries, i.e., joint plugs, gasket intersections, etc.

Regardless of the sealant used, the customer should contact the sealant manufacturer to determine compatibility and adhesion. Follow sealant manufacturer's proper application procedures and quality assurance programs for weather sealing.

Maintain caulk joints as shown in the approved shop drawings. Unless specified otherwise, most sealant manufacturers recommend a 3/8" minimum perimeter caulk joint. A 3/4" minimum joint is recommended at the head condition to accommodate thermal expansion and contraction.

Anchoring surfaces of perimeter construction must be level and plumb within the adjustable limits of the head, jamb, and sill framing.

## Section II: Perimeter Application

### Perimeter Application

- A.) For anchoring to perimeter and providing a spacer for glazing pockets at head, jamb, and sill.

**Note: Anchoring surfaces of perimeter constructions must be level and plumb within the adjustments of the head, jamb, or sill. See "APPROVED" shop drawings for adjustment limits.**

Fill gasket race w/ sealant in top and bottom of each vertical mullion and marry with perimeter sealant

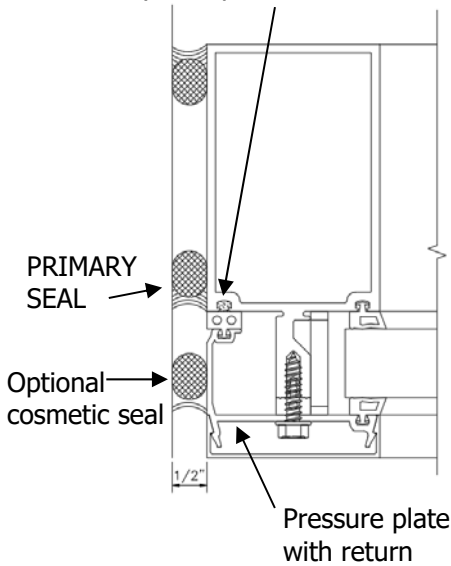

Plug open end of vertical each side of anchor stem to assist with carrying perimeter seal across the verticals. Head shown, sill similar. Plug material not by EFCO

"T" anchor at intermediate mullion. See approved drawings for fastener requirements

The erector must supply and apply bond breaker tape across the face of the anchor to prevent three-sided adhesion

Critical perimeter sealant is shown with two dotted lines.

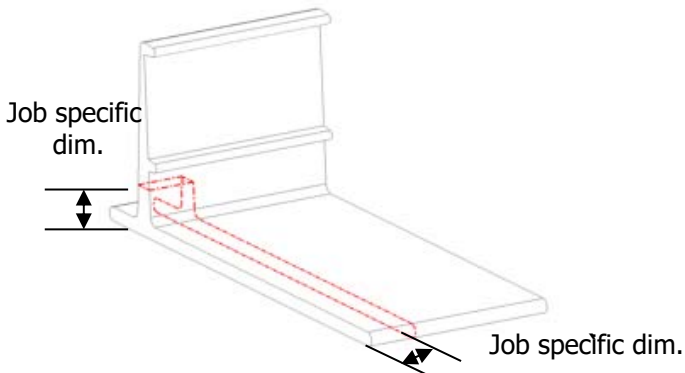
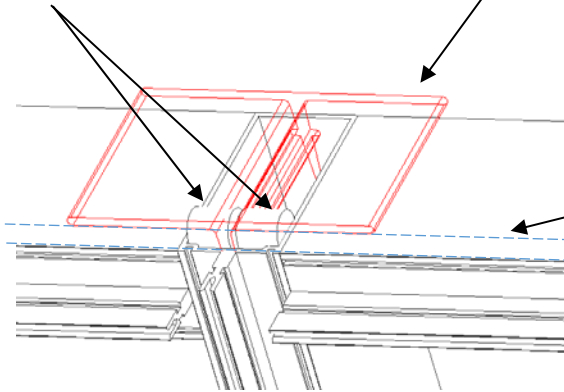

Custom notch of F and T anchors for aiding sealant application shown with dashed line above is available (by request only) and subject to additional fabrication charge. Notch dimensions are not standard and job specific dimensions must be supplied.

**Note: The perimeter caulking must be done prior to glazing. Reference the "APPROVED" shop drawings for caulk joint size unless otherwise specified. Most sealant manufacturers recommend a 3/8" minimum joint width.**

## Section II: Perimeter Application

### Perimeter Application

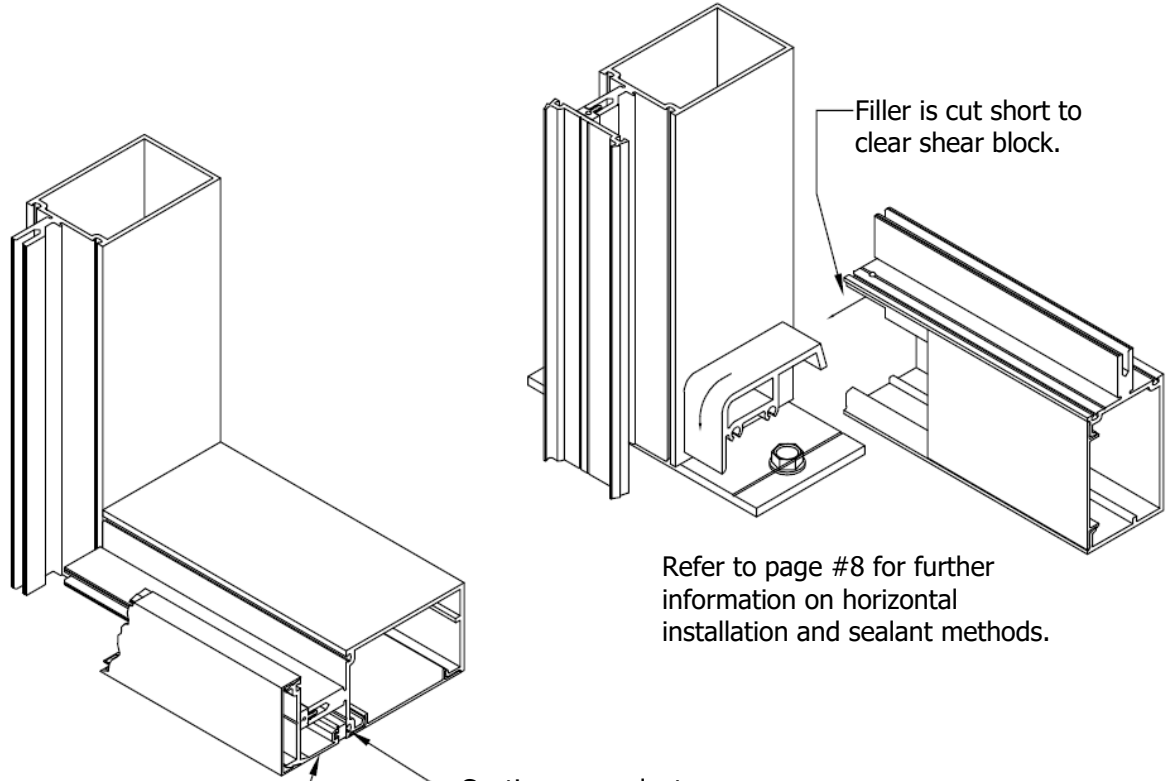

Refer to page #8 for further information on horizontal installation and sealant methods.

Continuous perimeter pressure plate joint at center line of mullion as shown below.

Continuous sealant.

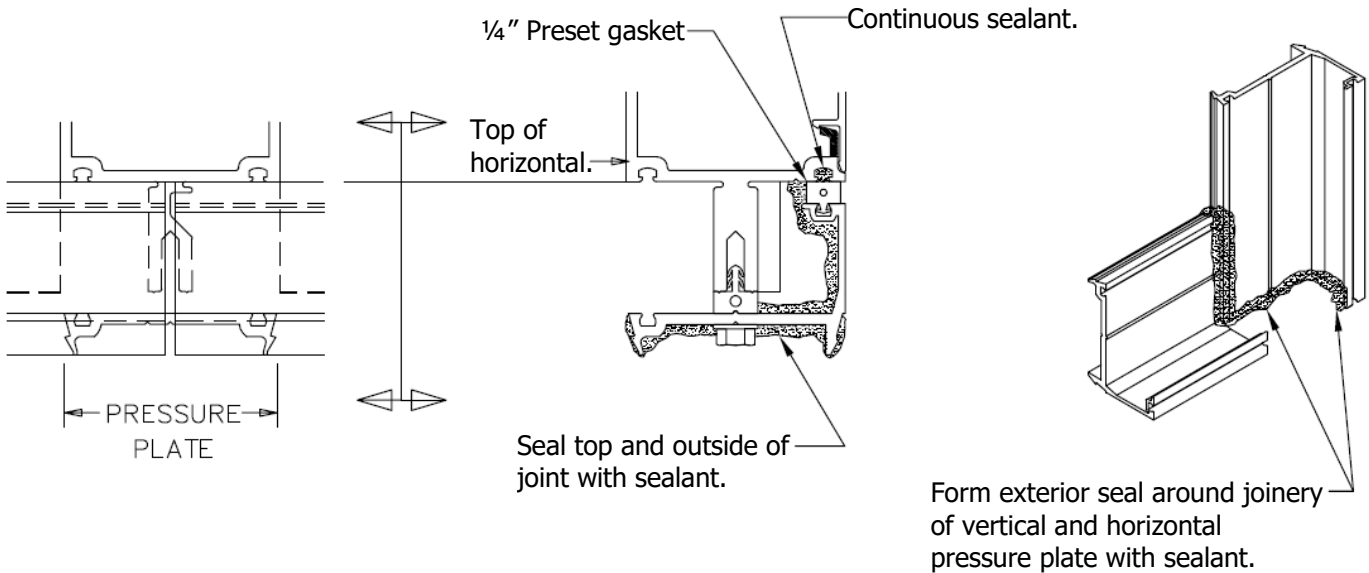

## **Section III: Anchor Installation**

### **Anchor Installation**

- A.) Attach anchors to mullions with temporary alignment screws as shown below.
- B.) Install the vertical mullions in position, and attach anchors to the building structure per the "APPROVED" shop drawings.

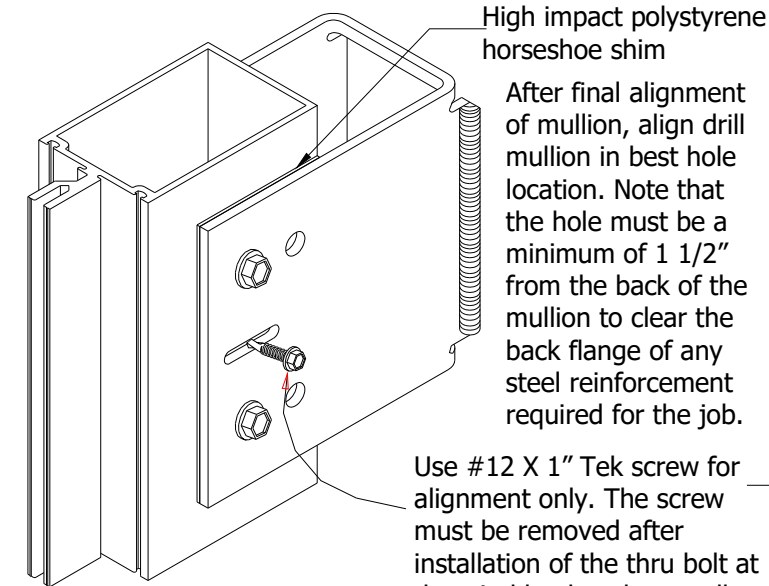

**Dead Load Anchors**  
Welded to building structure

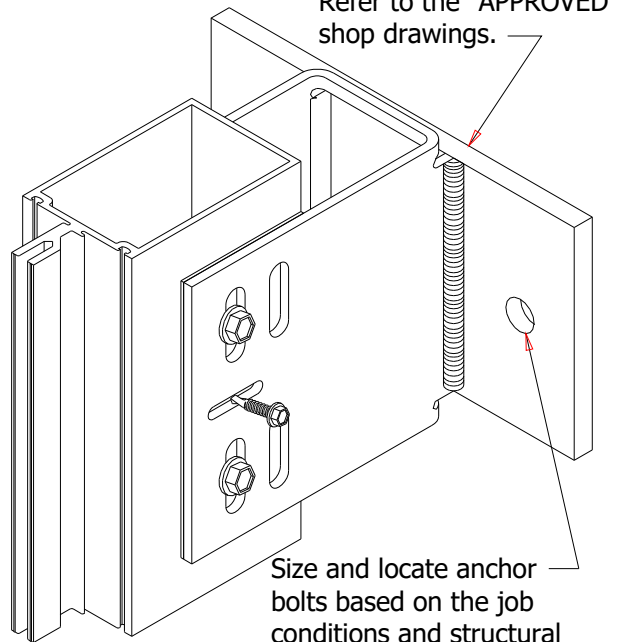
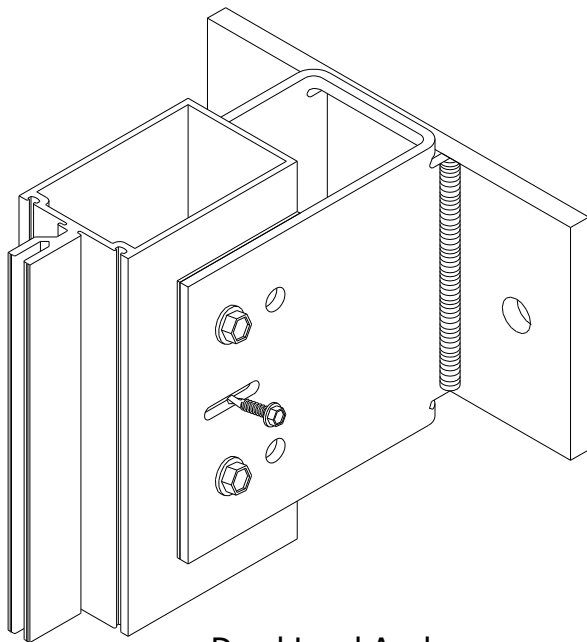
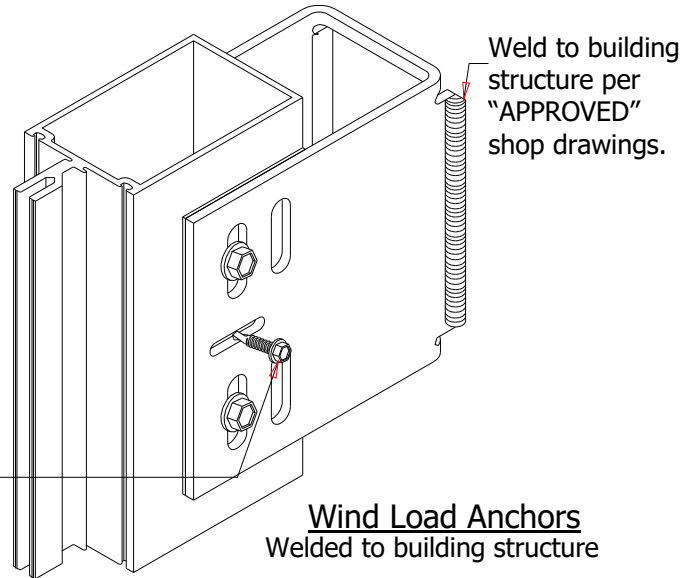

**Note: Elevation of slabs must be within adjustment limits of the anchorage system. See "APPROVED" shop drawings for allowable adjustment.**

## Section IV: Frame Assembly

### Frame Assembly

- A.) Assemble shear blocks, splices, anchors, etc. to mullions as required.
- B.) Install and anchor vertical mullions to form the vertical sections per "APPROVED" shop drawings.

**Note: Check overall frame dimensions on every 5 openings on long runs to avoid dimensional build-up.**

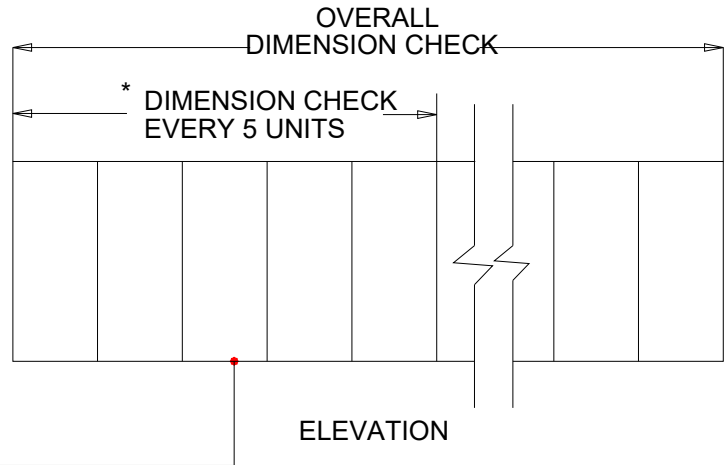

- C.) Attach horizontal members to the shear blocks. Fasten with screws thru the face of the horizontal members.
- D.) Interior horizontals are cut D.L.O. – 1/32". The erector is to split the difference on both sides.
- E.) Rotate the horizontal over the shear block from the interior of the system. With the horizontal in position, fasten with (1) PLFH Tek 3 screw on each end of horizontal and tighten as required.

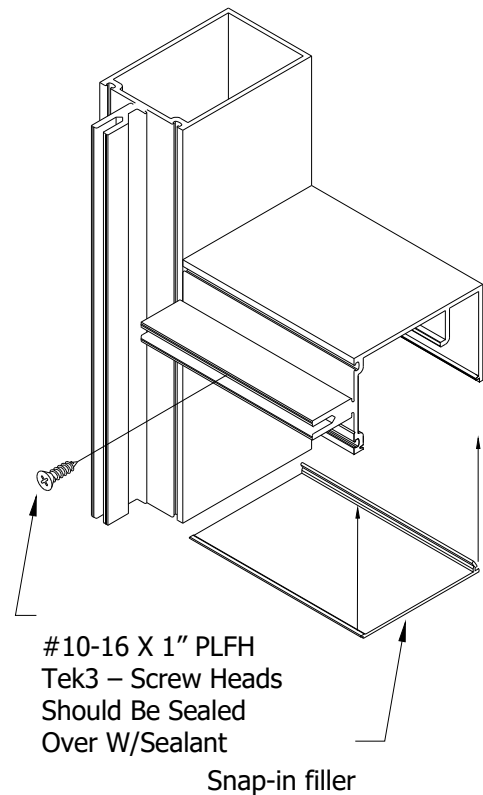
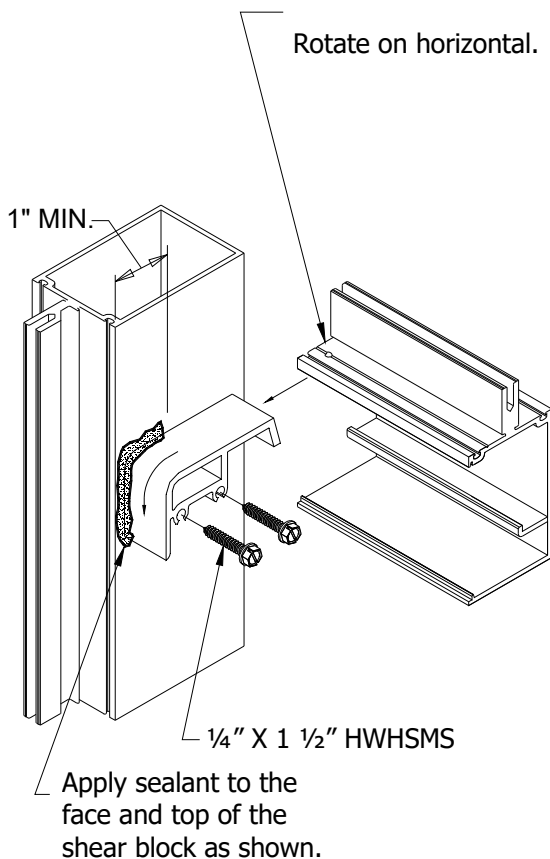

**Note: The commercial cut to length tolerance is +- 1/16". It is critical to check every 5<sup>th</sup> "UNIT" for location.**



## Section V: Vertical Splice Joints

### Vertical Splice Joints

- A.) Space vertical mullion expansion joints per "APPROVED" shop drawings.
- B.) Keep in mind that spacing may vary with job site temperature. On multiple stacked applications, key horizontals must be installed to establish grades regardless of expansion joint dimension.
- C.) Splice joints should occur at spandrel areas.
- D.) Mullion splice joints for this system are not designed to compensate for varying floor levels. (Reference "APPROVED" shop drawings for allowable adjustment, i.e., anchors.)
- E.) The splice joint width should be based on sealant movement capabilities and the following formula.

**Linear expansion for aluminum in inches = Length X F (temperature degrees difference in Fahrenheit) X .0000129.**

- F.) Where head clearance is insufficient to allow top mullions to be lifted over the splice sleeve, a retractable sleeve will be used. The sleeve is taped in the top mullion and dropped to the stop screw in the mullion below.
- G.) Do not match drill anchors until a check of expansion joints and wall installation is performed.

**Note: All anchors must be fixed before glazing begins.**

**Note: When the mullion splice is shop installed in the lower mullion, shear block screws will be used in the standard location as shown.**

**Erector Note: Apply no screws below splice in the upper pressure plate.**

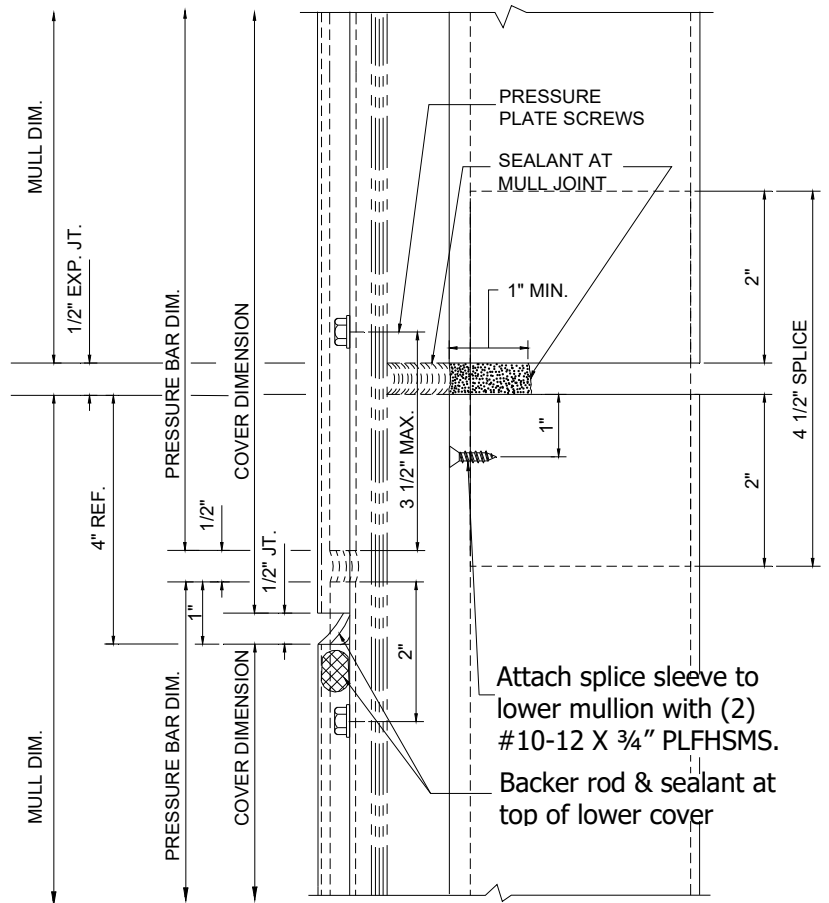
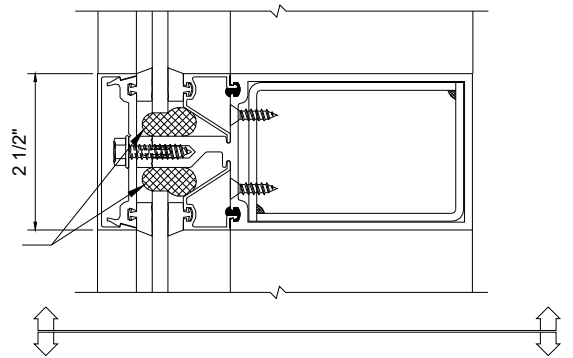

## Section VI: Joint Plug Application

### Joint Plug Application

- A.) Install the thermal isolator (70 Durometer) in the vertical mullion. Run continuously and butt joint as required with sealant.

**Note: All thermal isolators should be removed from the reels and allowed to shrink prior to installation.**

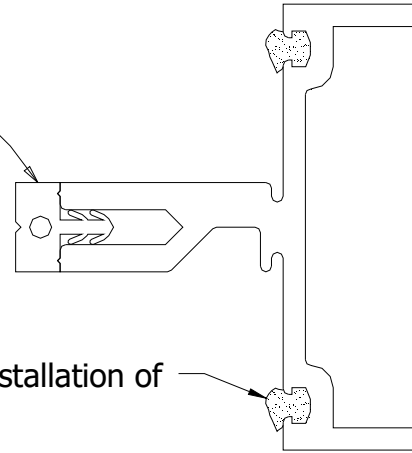

- B.) Seal vertical gasket raceway X 1" high prior to installation of joint plugs.

Install thermal isolator prior to installing the mullion plug.

Prior to installing the mullion plugs, seal all three sides of the pocket, making sure all cavities are filled.

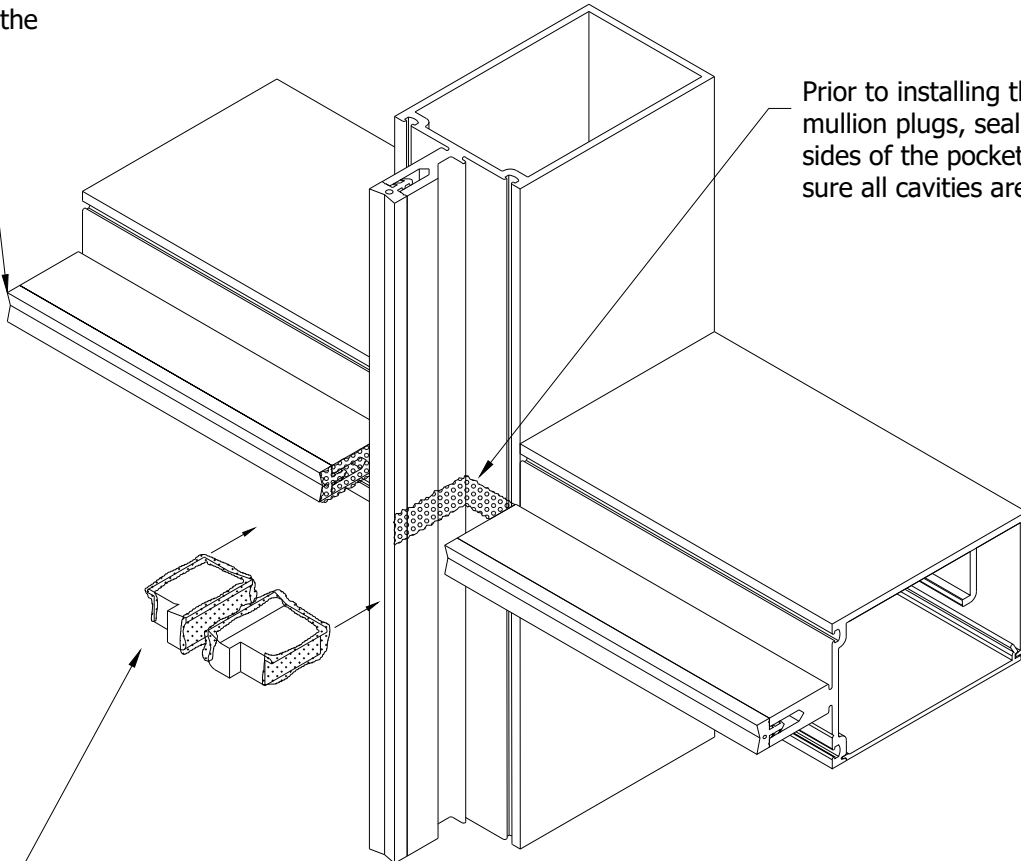

With sealant in place, mullion plugs can be installed. Note the mull plug is applied so that notch is located at the pressure plate gasket location. (Seal all three corresponding sides of mullion plug before installation so sealant on mullion plug will marry to sealant that is placed in the pocket.)

## Section VI: Joint Plug Application

### Joint Plug Application

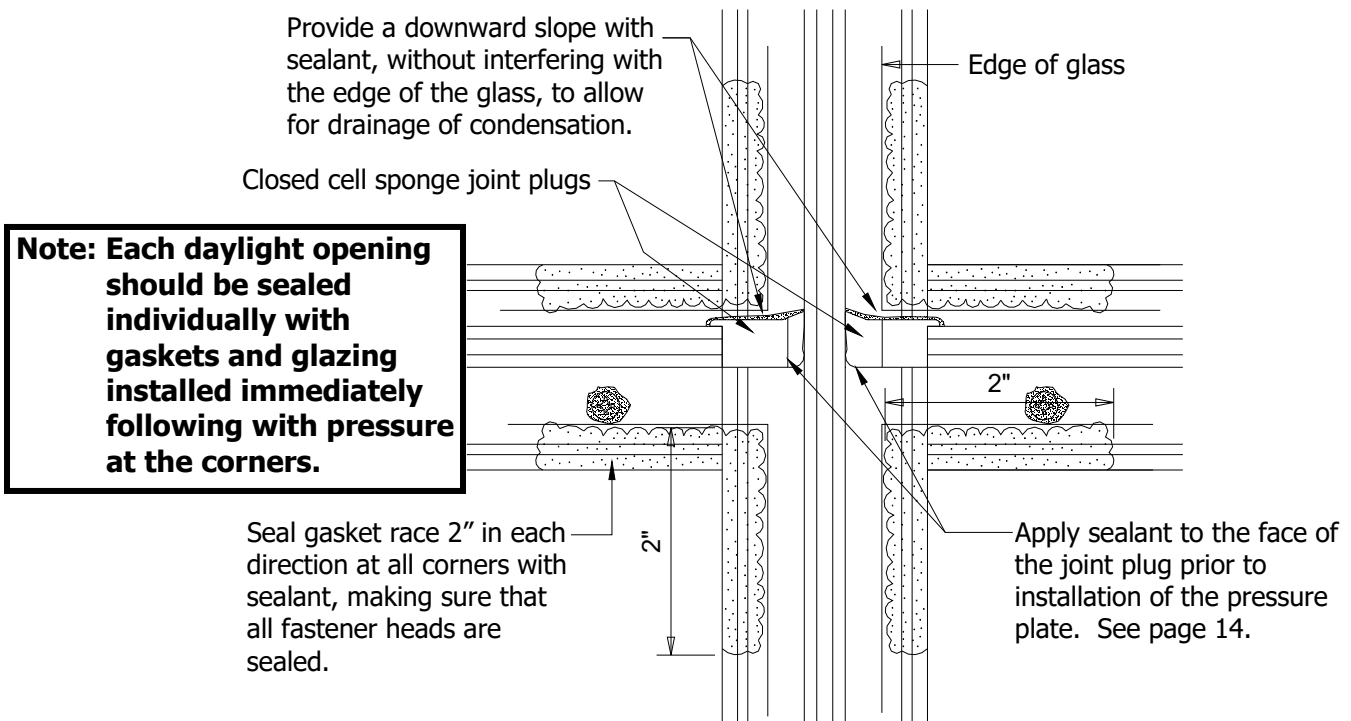
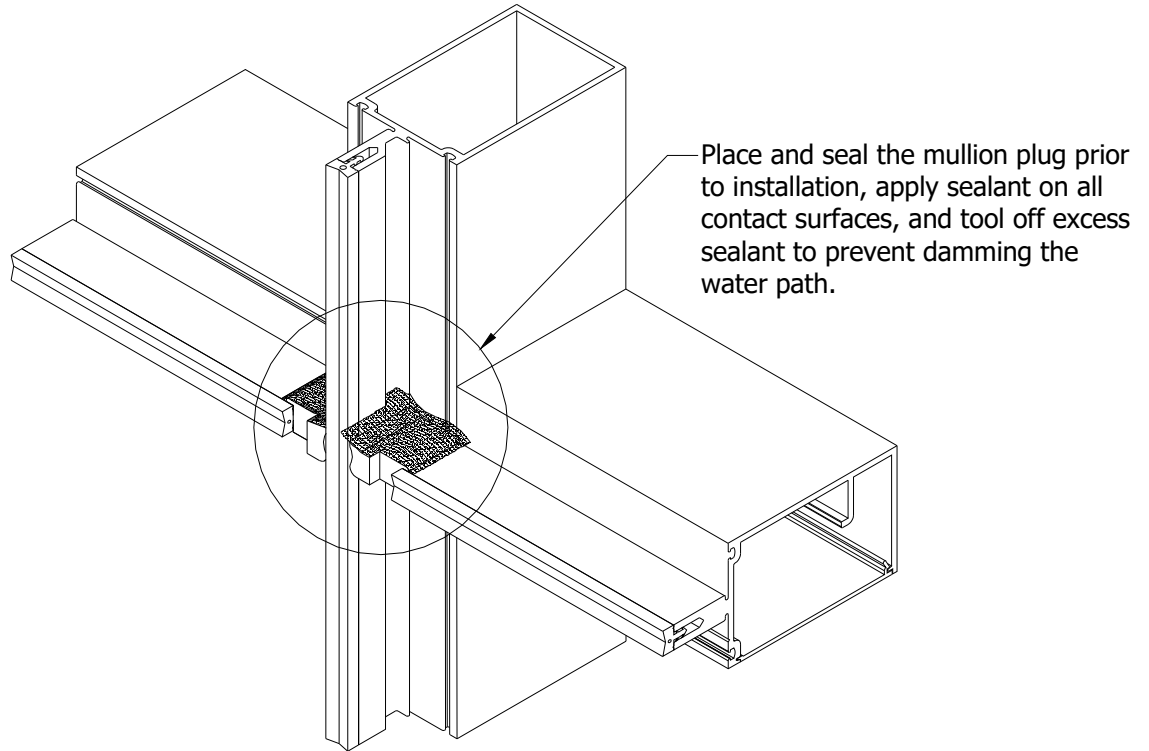

Elevation of Joinery  
Prior to setting the glass

## Section VII: Glazing Adaptors / Mullion Gaskets

### Installation of Glazing Adaptors at Openings for 1/4" & 1/2" Infills.

- A.) Position the vertical adaptors as shown.
- B.) Place horizontal adaptors between the verticals.
- C.) Seal adaptors by applying sealant to all four corners.
- D.) Cut Formula Vertical = D.L.O. + 1"
- E.) Cut Formula Horizontal = D.L.O. - 1/16"

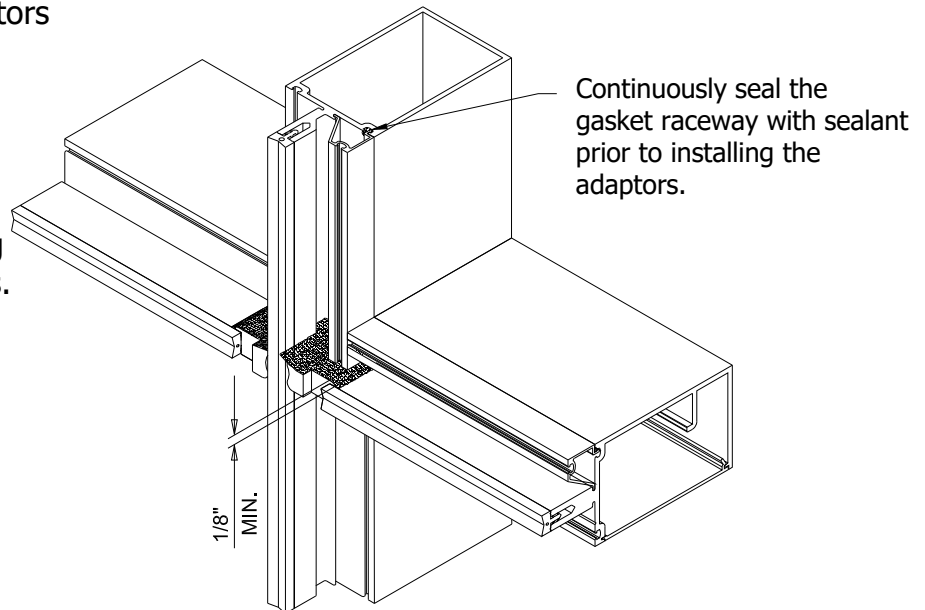

\* Vertical adaptors will need a minimum of 1/8" clearance above the joint plug, free from sealant.

**Note: Each daylight opening should be sealed individually with gaskets and glazing installed immediately following with pressure at the corners.**

### Apply Preset Glazing Gaskets to Mullions.

- A.) Apply sealant in the raceway a minimum 2" each way at all corners. (Ref. elevation in step.)
- B.) Remove the glazing gaskets from the reel and allow shrinking.
- C.) Cut vertical gaskets D.L.O. plus 1 3/4".
- D.) Cut horizontal gaskets D.L.O. plus 1/2".
- E.) Seal all gasket corners; pull horizontal gasket back, seal end and jamb into the vertical gasket to insure a snug fit. (See detail at right.)

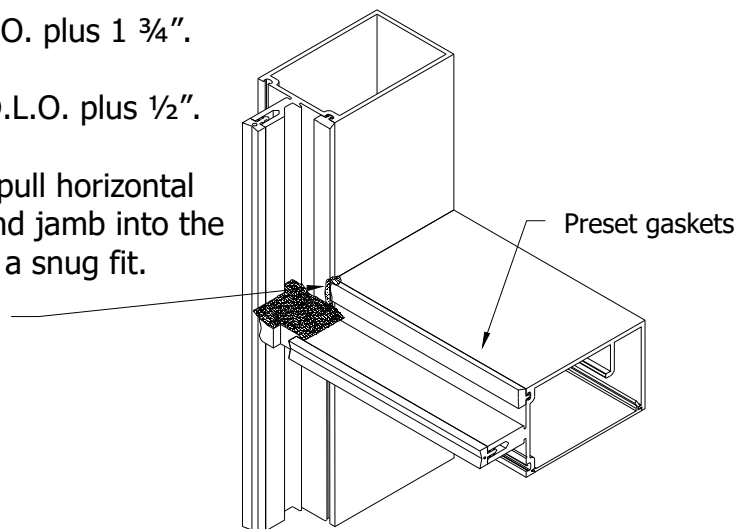

**Note: If the gaskets are difficult to install in the glazing race, a light coat of mineral spirits can be used to lubricate the gaskets.**

## Section VIII: Setting Blocks / Anti-Walk Blocks / Pressure Plate Gaskets

### Setting Blocks

- A.) Position and install the setting blocks as directed on the "APPROVED" shop drawings. Install appropriate infill per "APPROVED" shop drawings (Typical edge engagement "glass bite" is 1/2").
- B.) Center the infill in the opening. (Glass size = D.L.O. plus 1" width and height)

### Anti-Walk Blocks

- A.) Lift the infill slightly off the setting blocks, and press infill firmly against the interior glazing gaskets at the sill horizontal.
- B.) Install and position the side blocks as shown on the "APPROVED" shop drawings.

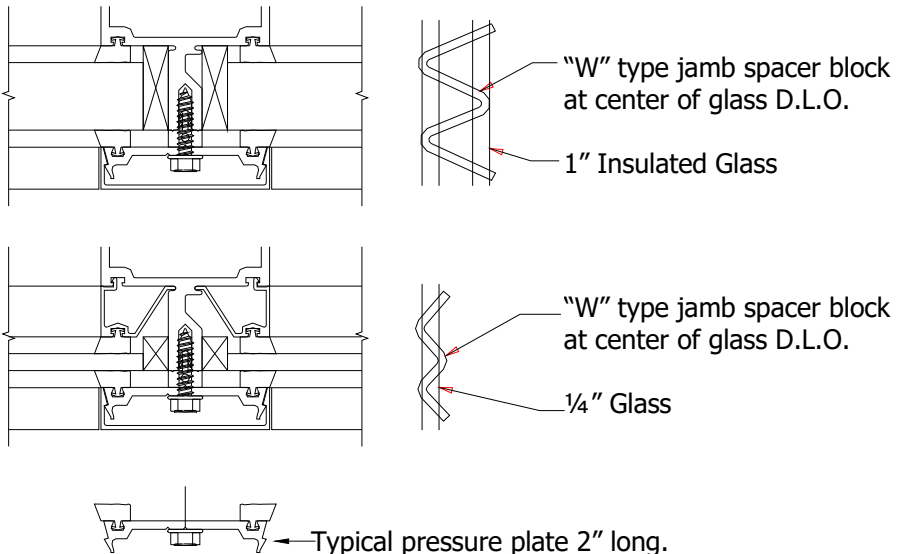

"Dutchmen" Temporary Retainers, are available from EFCO by request, and are considered an extra.

### Pressure Plate Gaskets

- A.) Apply the glazing gasket to the pressure plates. The gaskets applied to the vertical pressure plate are to be cut flush at both ends, except in "multi-story" applications where gaskets are to extend 1" beyond the end at expansion joints.
- B.) The gaskets applied to horizontal pressure plates are cut 1/4" long, both ends maximum.

**Note: The vertical gasket runs through the joint plug notch at the horizontal location. Seal all corners of the gaskets with sealant.**

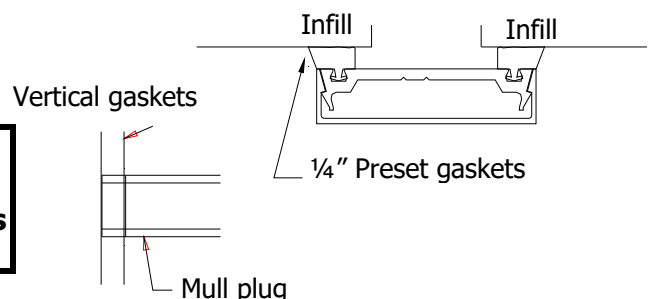

## Section IX: Pressure Plate Attachment

### Pressure Plate Attachment

- A.) Attach pressure plates with 1/4" X 1" stainless steel hex washer head pressure plate screws. Typical spacing is 6" on center.
- B.) Torque screws to 80 inch pounds. In cold weather, first torque all screws to 40 inch pounds.
- C.) When possible, work from the center outward on horizontals and from the sill upward on verticals.
- D.) Torque all screws to the full 80 inch pounds after all four sides of the opening have been clamped.

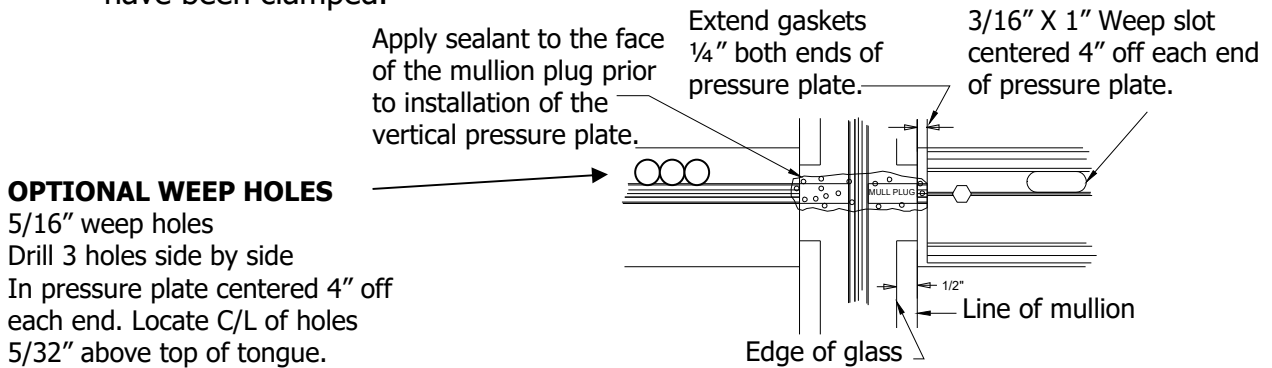

**Note: Reference page #9 for recommended pressure plates at the splice. Install the first screw approx. 3" from the end. Typical screw spacing is 6" O.C. Glazier should always place a screw in the vertical pressure plate directly opposite each horizontal. This will provide maximum control of pressure on the mullion plugs that provides critical sealing function.**

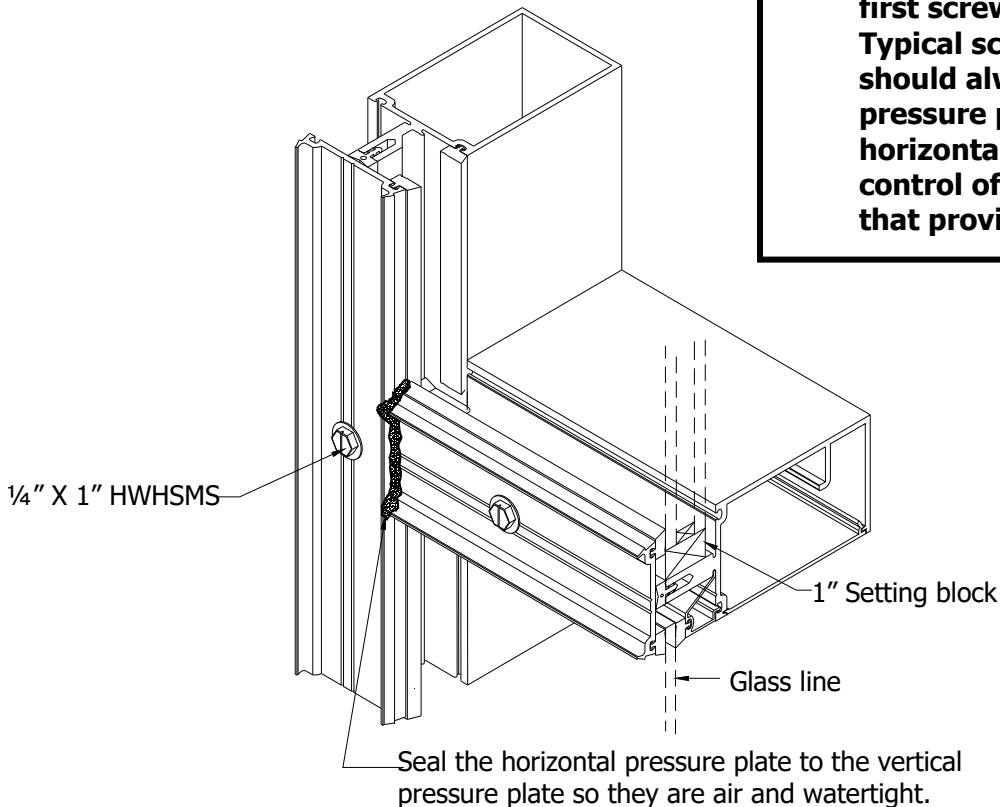

**Customer / Installer Note: EFCO setting blocks are typically 4" in length with different depths. If the glazing infill is "NOT BY EFCO" and glazing sizes are larger than 40 square feet, then the glazing details must be reviewed by the glazing manufacturer for proper setting block size.**

## Section X: Exterior Cover Installation

### Snap On Exterior Covers

- A.) Set vertical covers as shown on "APPROVED" shop drawings.

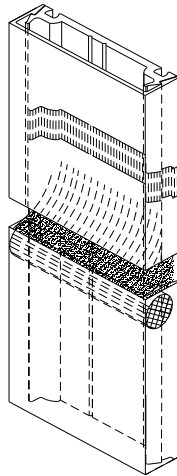
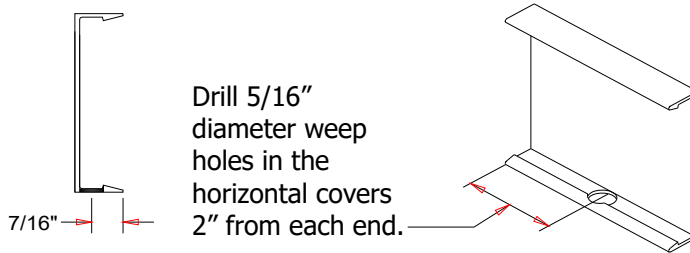

**Note: Care must be taken to avoid damage to the covers during installation. Use a nominal 12" long 2 X 4 and mallet or hammer to seat the cover.**

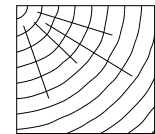
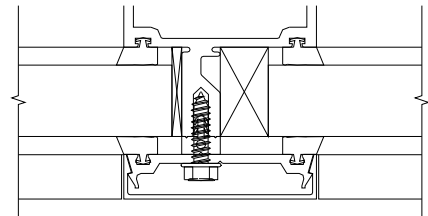

Approx. 12" long wood block

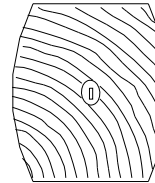

Mallet or hammer

- B.) Center the horizontal snap cover in the opening, align and engage one side, then use a block and mallet to engage the opposite side.
- C.) Gaps at the ends should be equalized, and are provided to allow installation, thermal movement, and weepage.
- D.) Exterior horizontal covers are cut D.L.O. – 1/16".
- E.) The erector is to split the difference on both ends.

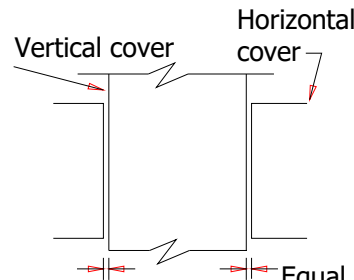

Equal space at both ends of horizontal cover.

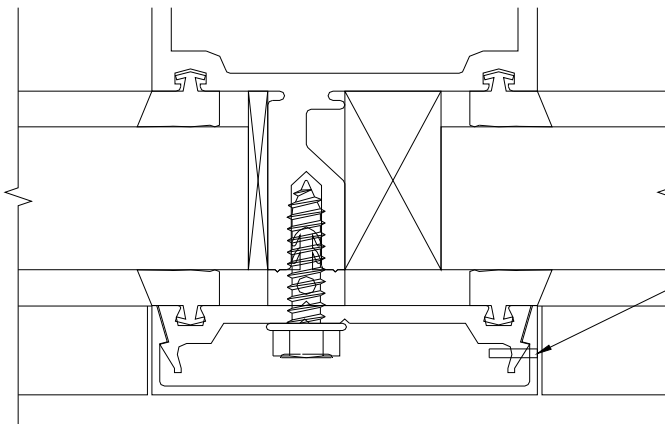

**Note: Horizontal covers 1" or more in depth must be mechanically attached, similar to detail below.**

A 1/16" X 5/16" roll pin at the center of the cut length is recommended to prevent slippage. The roll pin can be located at the horizontal to eliminate exposure.

## Section XI: Steel Reinforcement

### Steel Reinforcement

- A.) At large spans or in high wind load areas, steel reinforcement may be necessary.
- B.) Reinforcement requirements will vary on a per job basis.
- C.) Reference the "APPROVED" shop drawings for steel requirements and locations.

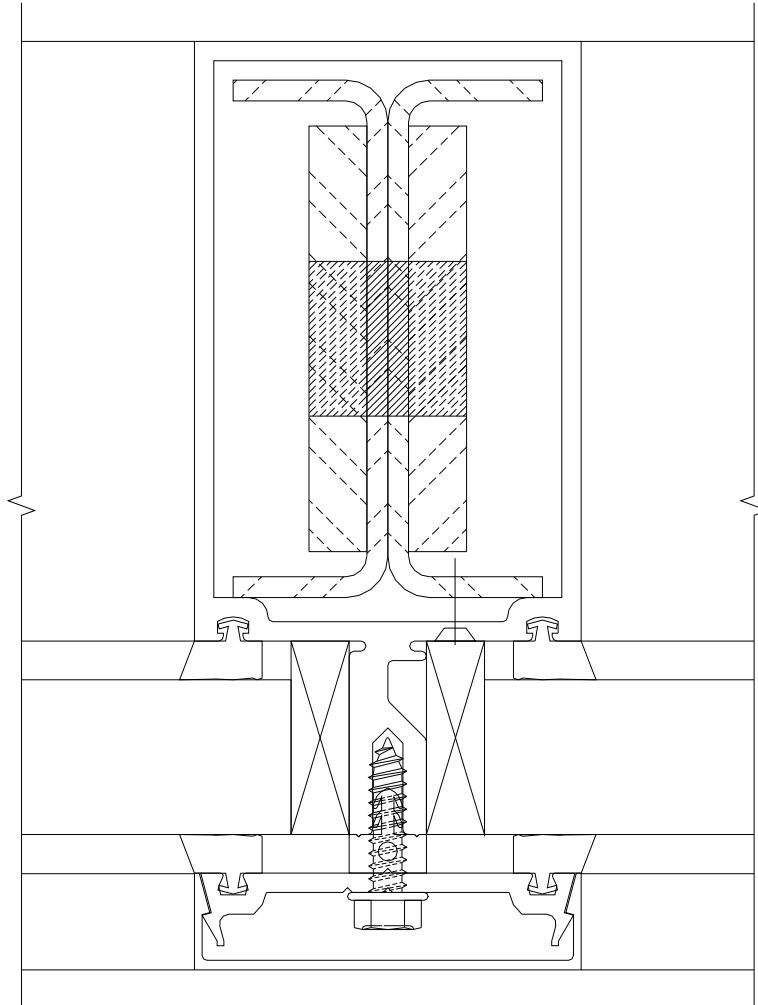

- D.) When steel reinforcement is factory installed in the mullions, use fasteners to prevent damage or slippage of the steel during shipping.