

INSTALLATION

TRIFAB® VG

SSG & WEATHERSEAL STICK ASSEMBLY

- TRIFAB VG 450
- TRIFAB VG 451
- TRIFAB VG 451T

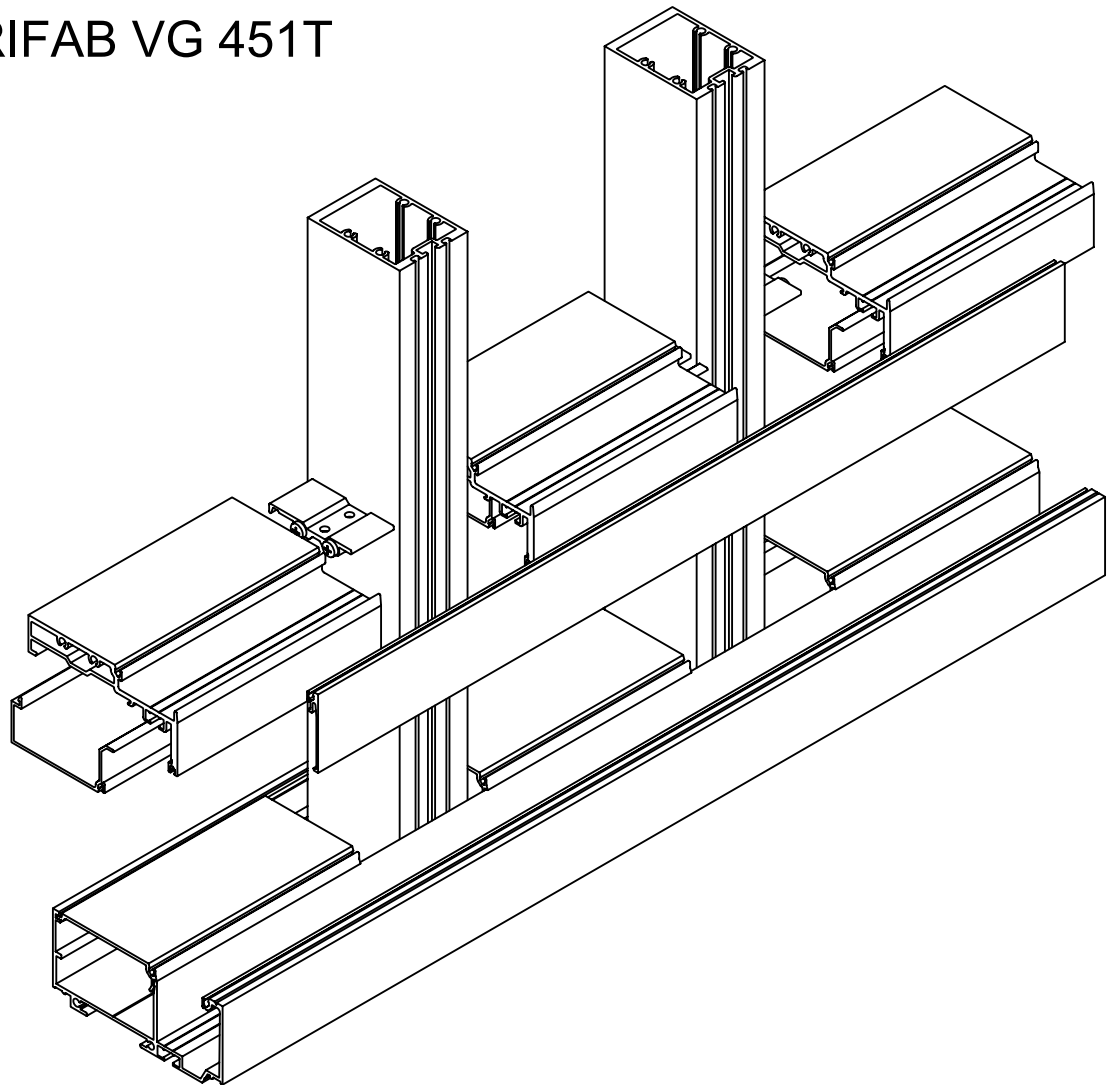

INSTRUCTIONS

These instructions show the general installation sequence and procedure for typical installation.
They supplement the shop details and notations on installation and glazing.

SECTION	PAGE	
I	3-4	GENERAL NOTES
II	5	BASIC FRAMING DETAILS
III	6-14	FABRICATION
IV	15-26	INSTALLATION
V	27-28	DOOR JAMB FABRICATION AND INSTALLATION
VI	29-33	GLAZING

Laws and building and safety codes governing the design and use of glazed entrance, window, and curtain wall products vary widely. Kawneer does not control the selection of product configurations, operating hardware, or glazing materials, and assumes no responsibility therefor.

Kawneer reserves the right to change configuration without prior notice when deemed necessary for product improvement.

© Kawneer Company, Inc. 2009

HANDLING, STORING, AND PROTECTION OF ALUMINUM

The material must be protected against damage. The following precautions are recommended to assure early acceptance of your products and workmanship.

A. HANDLE CAREFULLY - Don't drop from the truck. Stack with adequate separation so material will not rub together. Store off the ground. Protect against elements and other construction trades. Wear hand protection to prevent injury due to sharp edges of cut extrusions.

B. KEEP MATERIAL AWAY FROM WATER, MUD AND SPRAY - Prevent cement, plaster, or other materials from damaging the finish.

C. PROTECT THE MATERIALS AFTER ERECTION - Protect by wrapping with Kraft paper or by erecting Visqueen or canvas splatter screen. Cement, plaster, terrazzo, other alkaline solutions and acid based materials used to clean masonry are very harmful to the finish and should be removed with water and mild soap IMMEDIATELY.

GENERAL INSTALLATION NOTES

The following practices are recommended for all installations:

A. CHECK SHOP DRAWINGS, INSTALLATION INSTRUCTIONS and GLAZING INSTRUCTIONS to become thoroughly familiar with the project. The SHOP DRAWINGS take precedence and include specific details for the project. The INSTALLATION INSTRUCTIONS are of a general nature and cover most common conditions.

B. All materials are to be INSTALLED PLUMB, LEVEL, AND TRUE.

C. All work should start from bench marks and/or column lines as established by the ARCHITECTURAL DRAWINGS and the GENERAL CONTRACTOR. Check mullion spacing from both ends of masonry opening to prevent dimensional build-up of day light opening.

D. Make certain that construction which will receive your materials is in accordance with the contract documents. If not, notify the GENERAL CONTRACTOR IN WRITING and resolve differences before proceeding with your work.

E. Isolate all aluminum to be placed directly in contact with uncured masonry or incompatible materials with a heavy coat of zinc chromate or bituminous paint.

F. Check all materials on arrival for quantity and be sure you have everything required to begin installation.

G. Sealants must be compatible with all materials with which they have contact, including other sealant surfaces. Consult with sealant manufacturer for recommendations relative to joint size, shelf life, compatibility, priming, tooling, adhesion, etc.

H. PERIMETER FASTENING - "Fastening" means any method of securing one part to another or to adjacent materials. These instructions specify only those fasteners used within the system. Due to varying perimeter conditions and job performance requirements, anchor fasteners are not specified in these instructions. Refer to the Shop Drawings or consult a structural engineer for fastener type, sizing, and location.

I. CHECK OPENINGS - Make certain that the opening which will receive your materials is in accordance with the contract documents. If not, notify the General Contractor in writing and resolve differences before proceeding with your work.

J. BUILDING CODES - Glass and glazing codes governing the design and use of products vary widely. Kawneer does not control the selection of product configurations, operating hardware, or glazing materials, and assumes no responsibility for these design considerations. It is the responsibility of the owner, specifier, architect, general contractor and the installer to make these selections in strict conformance with all applicable codes.

K. EXPANSION JOINTS - Expansion joints and perimeter seals shown in these instructions and in the shop drawings are shown at normal size. Actual dimensions may vary due to perimeter conditions and /or difference in metal temperature between the time of fabrication and time of installation. For example, a 12 foot unrestrained length of aluminum extrusion can expand or contract 3/32" over a 50° F temperature change. Any movement potential should be accounted for at the time of installation.

L. FIELD TESTING - It is recommended that a Water Hose Test be conducted once a sufficient portion of the framing is installed, glazed and caulked to ensure proper installation. The Water Hose Test shall be conducted in accordance with AAMA 501.2. In addition, larger projects should have periodic Water Hose Tests as additional precautionary measures.

M. GASKET INVENTORY ROTATION - These high quality rubber extrusions are coated with silicone lubricant. Silicone will dry over time leaving a white "chalky" residue. Please rotate your stock "FIRST IN - FIRST OUT". If the rubber becomes dry, you may use water ONE TIME to reconstitute the silicone, after that, use a soap water solution.

SILICONE GLAZING NOTE

This SSG system requires structural silicone. The glazing installer is responsible for selecting and contacting the silicone manufacturer to determine which type of silicone is to be used and what samples are required to be submitted for adhesion and compatibility testing. The silicone sealant shall not be applied to Kawneer products without the approval of the silicone manufacturer and until all required testing is completed and detailed application instructions have been delivered to the installer by the silicone manufacturer. If you find the silicone manufacturer's installation instructions are not in accordance with Kawneer's installation instructions, it is your responsibility to notify Kawneer of the conflict **prior to glazing**.

Your glass supplier must be made aware that their glass will be used in an SSG application. The application must be approved by the glass supplier **prior to glazing**.

For any structural silicone glazed product application that is not shown in Kawneer's standard literature, the application must be approved.

Laws and building and safety codes governing the design and use of glazed entrance, window, and curtain wall products vary widely. Kawneer does not control the selection of product configurations, operating hardware, or glazing materials, and assumes no responsibility therefor.

Kawneer reserves the right to change configuration without prior notice when deemed necessary for product improvement.
© Kawneer Company, Inc. 2009

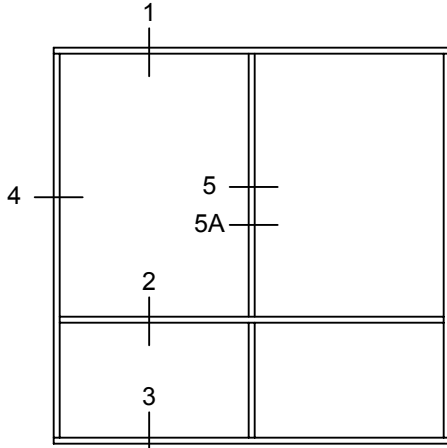

ELEVATION IS NUMBER
KEYED TO DETAILS

NOTES:

- 1) IF THE END REACTION OF THE MULLION (MULLION SPACING (FT.) TIMES HEIGHT (FT.) TIMES SPECIFIED WINDLOAD (PSF) DIVIDED BY TWO) IS GREATER THAN 500 LBS., APPLICATION ENGINEERING MUST BE CONSULTED.
- 2) IF OPENING IS OVER 24' WIDE, A SPLICE JOINT IS REQUIRED EVERY 12'. (SEE SPLICE JOINT PROCEDURE ON PAGE 16)

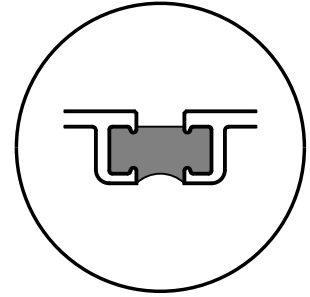

TRIFAB® VG 451T
THERMALLY BROKEN MEMBERS

SSG INSIDE GLAZED

SSG INSIDE GLAZED
TWO COLOR

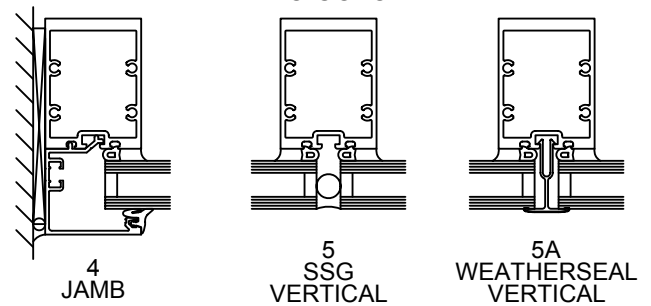
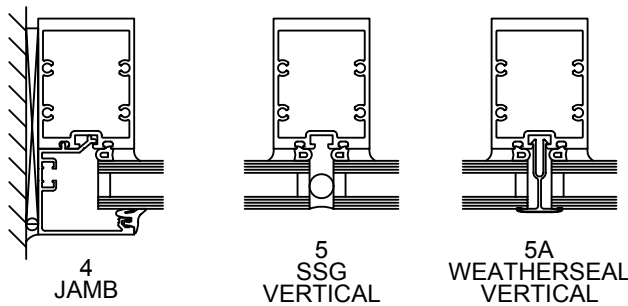

1
HEAD

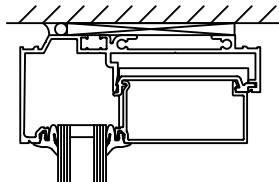

1
HEAD

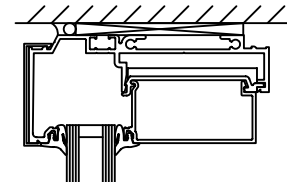

2
HORIZONTAL

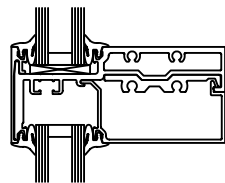

2
HORIZONTAL

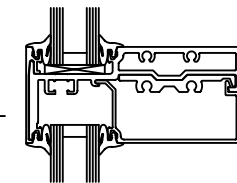

3
SILL

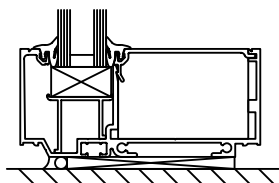

3
SILL

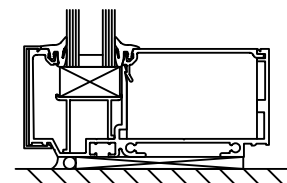

Laws and building and safety codes governing the design and use of glazed entrance, window, and curtain wall products vary widely. Kawneer does not control the selection of product configurations, operating hardware, or glazing materials, and assumes no responsibility therefor.

Kawneer reserves the right to change configuration without prior notice when deemed necessary for product improvement.

© Kawneer Company, Inc. 2009

FRAMING MEMBER

CUT FORMULA

MULLION	WITHOUT ANCHORS	FRAME HEIGHT MINUS 1-1/16"
MULLION	WITH ANCHORS	FRAME HEIGHT MINUS 1-7/16"
JAMB		FRAME HEIGHT MINUS 13/16"
JAMB ADAPTOR		FRAME HEIGHT MINUS 4-1/2"
CORNER MULLION		FRAME HEIGHT MINUS 1-1/16"
RECEPTORS		FRAME WIDTH PLUS 1/4" (SUBTRACT 1/2" FOR EACH SPLICE JOINT)
RECEPTOR COVER FOR TWO COLOR OPTION		SAME AS THE RECEPTOR
HEAD AND SILL INSERTS (SEE PAGES 11-14 FOR CORNER INSERT FORMULAS)		DLO
HORIZONTALS (SEE PAGES 11-14 FOR CORNER HORIZONTALS FORMULAS)		DLO
HORIZONTAL COVER		JAMB TO JAMB MINUS 1/16" (SEE NOTE #1 BELOW)
GLASS STOPS		DLO-1/16"
VERTICAL GLAZING ADAPTORS (SEE PAGES 29 & 30 FOR SSG ADAPTORS FORMULAS)		PARTIAL LENGTHS = DLO + 1/2" FULL LENGTHS = SAME AS THE MULLION (NOT SSG)
HORIZONTAL GLAZING ADAPTORS		DLO
WEATHERSEAL		DLO + 1" (SEE NOTE #2 BELOW)

NOTE # 1

CUT HORIZONTAL COVER TO LENGTH. HORIZONTAL COVER RUNS FROM JAMB TO JAMB. HORIZONTAL COVER LENGTH SHOULD NOT EXCEED 10' FEET. IF OPENING EXCEEDS 10' FEET, SPLICE HORIZONTAL COVER AT CENTERLINE OF VERTICAL MULLION LEAVING A 1/4" GAP. REFERENCE PAGES 32 AND 33 FOR SPLICE INFORMATION.

NOTE # 2

REQUIRED FABRICATION FOR WEATHERSEAL BELOW

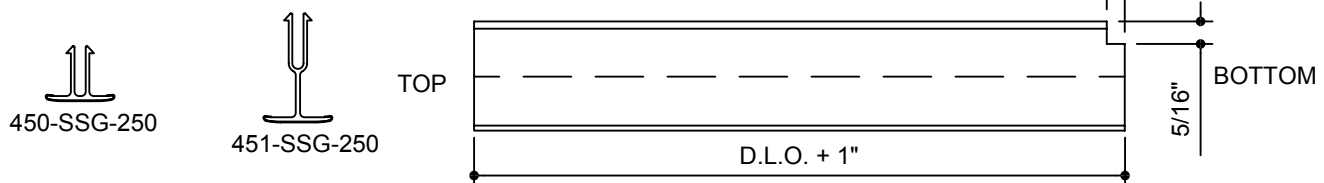

Laws and building and safety codes governing the design and use of glazed entrance, window, and curtain wall products vary widely. Kawneer does not control the selection of product configurations, operating hardware, or glazing materials, and assumes no responsibility therefor.

Kawneer reserves the right to change configuration without prior notice when deemed necessary for product improvement.
© Kawneer Company, Inc. 2009

STEP A: Cut mullion members to required length for either Lightweight Receptor or Standard Receptor.

STEP B: At desired horizontal locations align the top of the drill jig with the top of the horizontal. Drill the proper holes in the vertical members for attachment of the shear blocks.

STEP C: Attach shear blocks to verticals using the two 028-400 (#10 x 1-19/32" PHTF) supplied screws.

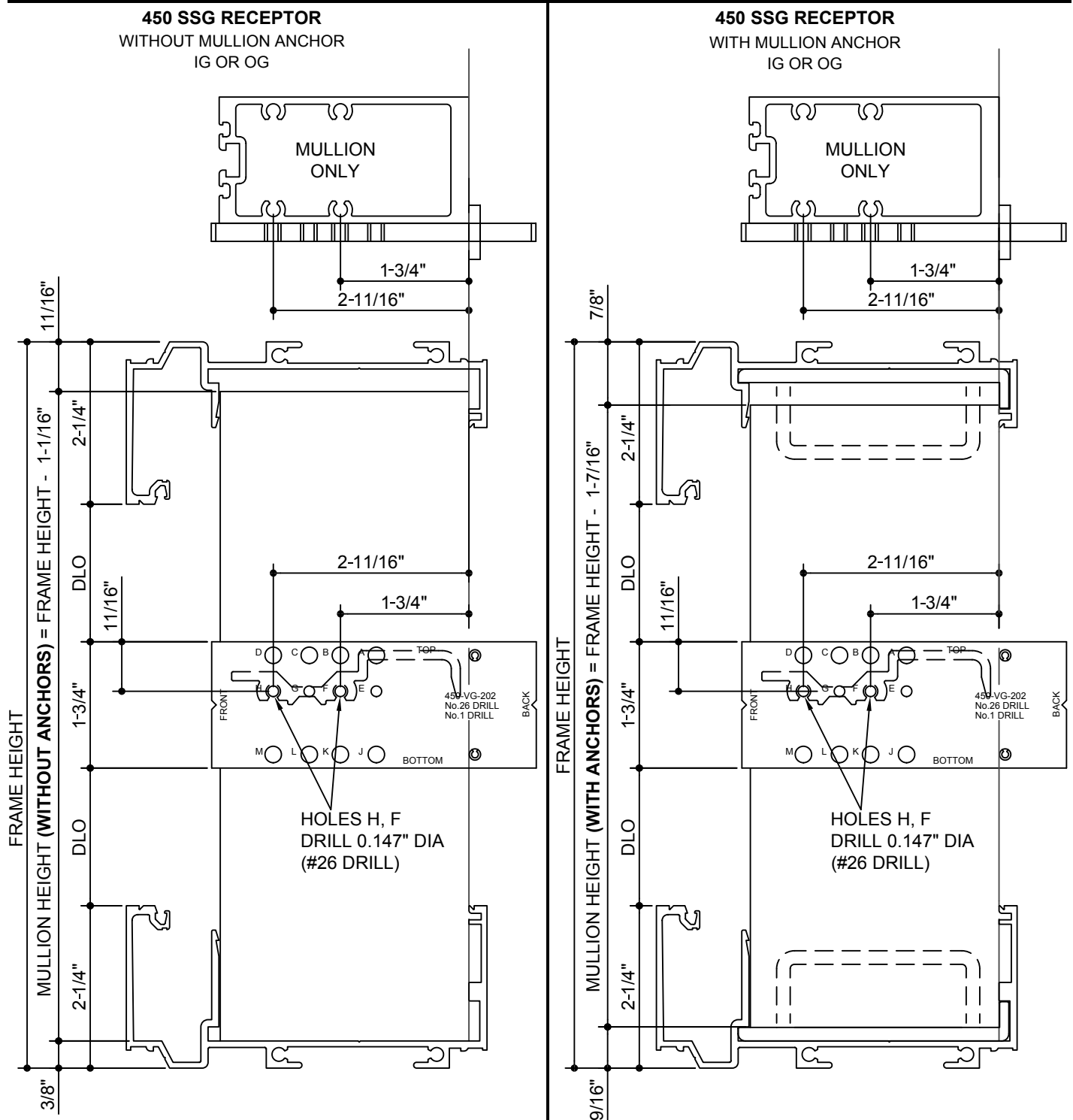

Laws and building and safety codes governing the design and use of glazed entrance, window, and curtain wall products vary widely. Kawneer does not control the selection of product configurations, operating hardware, or glazing materials, and assumes no responsibility therefor.

Kawneer reserves the right to change configuration without prior notice when deemed necessary for product improvement.
© Kawneer Company, Inc. 2009

STEP A: Cut mullion members to required length (either with or without mullion anchors).

STEP B: At desired horizontal locations align the top of the drill jig with the top of the horizontal. Drill the proper holes in the vertical members for attachment of the shear blocks.

STEP C: Attach shear blocks to verticals using the two 028-400 (#10 x 1-19/32" PHTF) supplied screws.

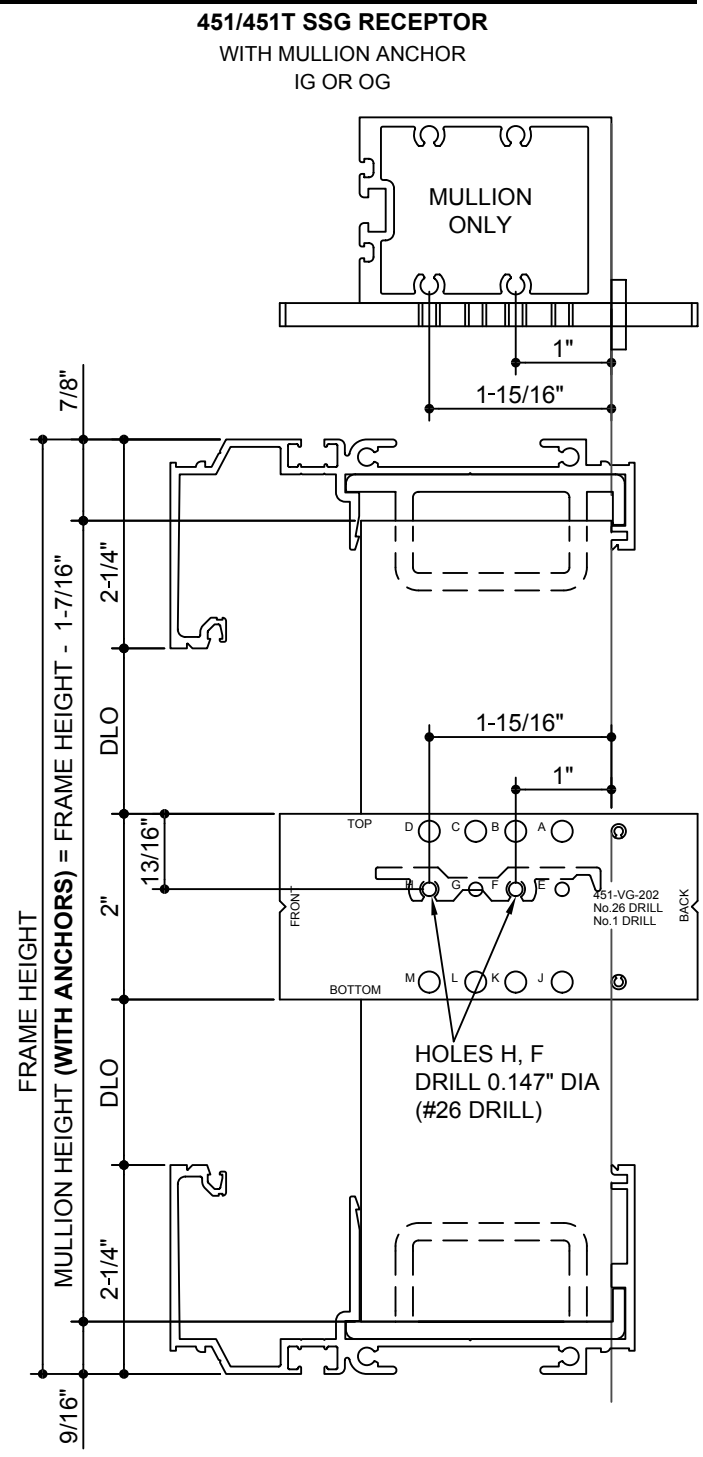
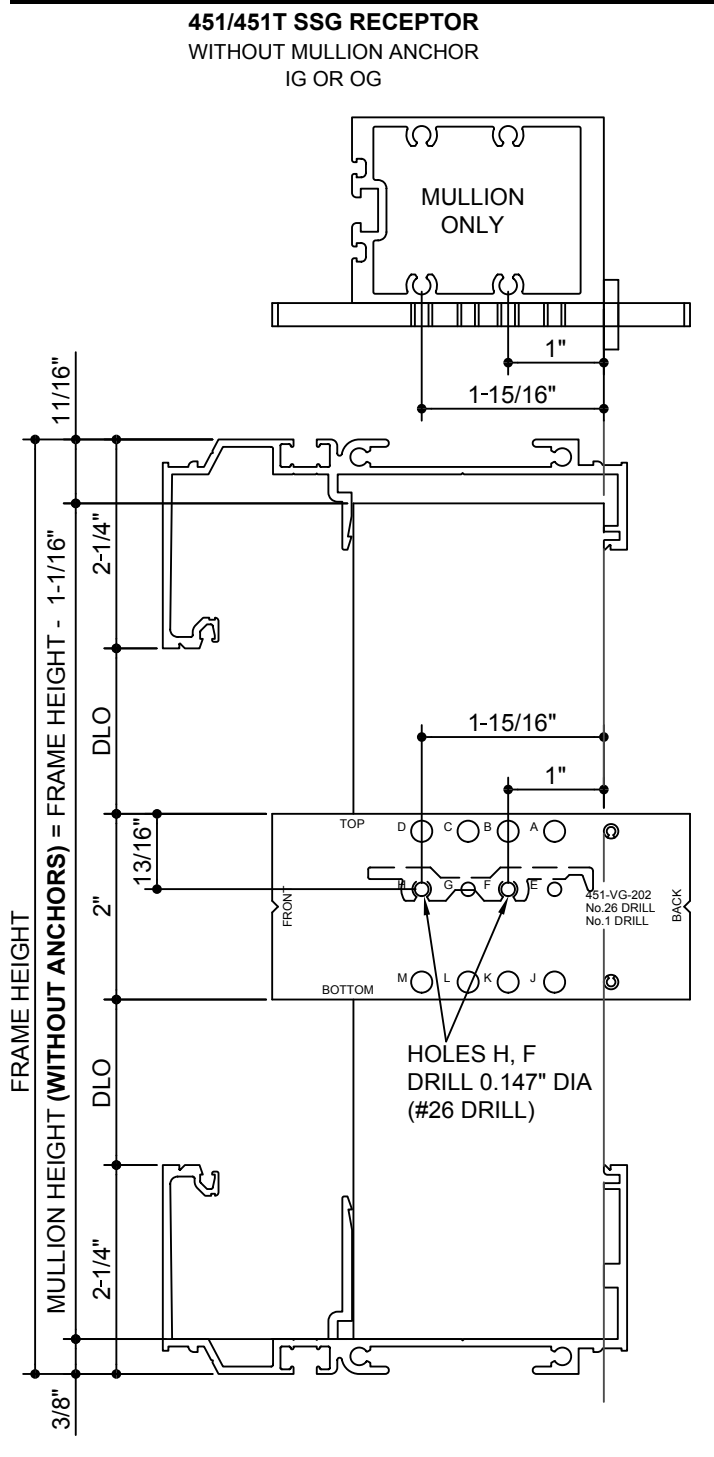

Laws and building and safety codes governing the design and use of glazed entrance, window, and curtain wall products vary widely. Kawneer does not control the selection of product configurations, operating hardware, or glazing materials, and assumes no responsibility therefor.

Kawneer reserves the right to change configuration without prior notice when deemed necessary for product improvement.
© Kawneer Company, Inc. 2009

Measure the opening to determine length of vertical and horizontal framing members. Allow 1/4" minimum clearance at the head, sill, and each jamb to facilitate installation and provide space for caulking. If job conditions are uncertain, or masonry openings are irregular, allow extra clearance to accommodate construction tolerance.

HEAD RECEPTORS:

- STEP A:** Cut Head Receptor to length.
- STEP B:** Drill anchor clear holes in receptors as required.
- STEP C:** Apply sealant to ends of receptor. (Figure 1)
- STEP D:** Apply end dams to receptor with two 028-856 (#12 x 1-1/8" PHTF) supplied screws, and seal over heads. Tool sealant along outside edges and inside corners between end dam and receptor. (Figure 2)

NOTE:

1) REFER TO SHOP DRAWINGS OR CONSULT ENGINEERING FOR PERIMETER FASTENER SIZE AND LOCATIONS.

2) IF OPENING IS OVER 24' WIDE, A SPLICE JOINT IS REQUIRED EVERY 12'. SEE SPLICE JOINT INSTALLATION ON PAGE 16. IF AN ENTRANCE IS REQUIRED, SEE ENTRANCE INSTALLATION ON PAGES 27-28.

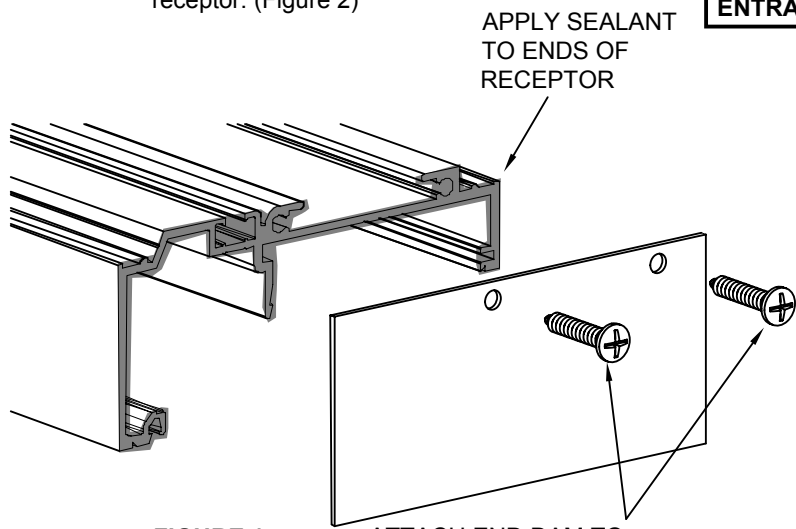

FIGURE 1

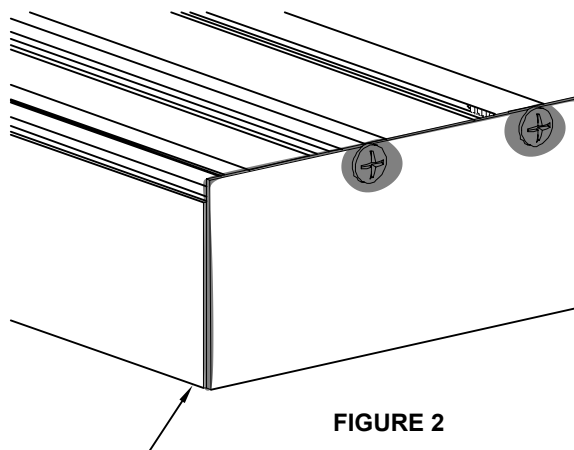

FIGURE 2

ATTACH END DAM TO RECEPTORS WITH SUPPLIED FASTENERS

TOOL SEALANT

SILL RECEPTORS:

- STEP A:** Cut Sill Receptor to length.
- STEP B:** Drill anchor clear holes in receptors as required.
- STEP C:** Drill one 5/16" weep hole at centerline of each D.L.O. in exterior face of sill receptor as shown below.
- STEP D:** Apply sealant to ends of receptor. (Figure 4)
- STEP E:** Apply end dams to receptor with two 028-856 (#12 x 1-1/8" PHTF) supplied screws, and seal over heads. Tool sealant along outside edges and inside corners between end dam and receptor. (Figure 4)

NOTE:

PERIMETER STRAP ANCHORS MUST BE INSTALLED PRIOR TO INSTALLING END DAMS AND INSTALLING IN THE OPENING.

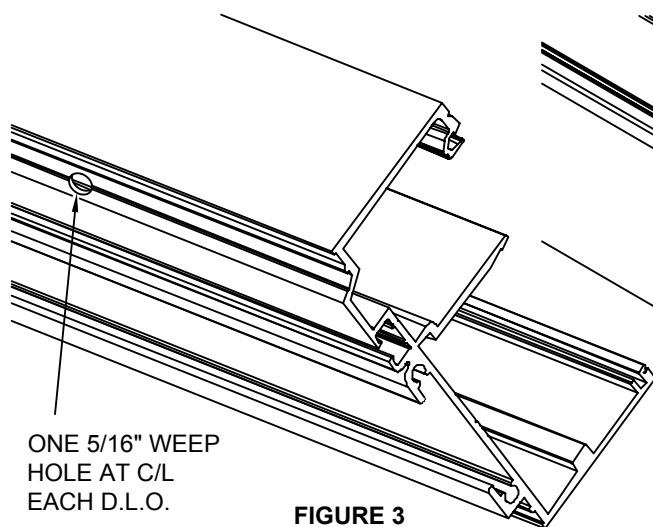

FIGURE 3

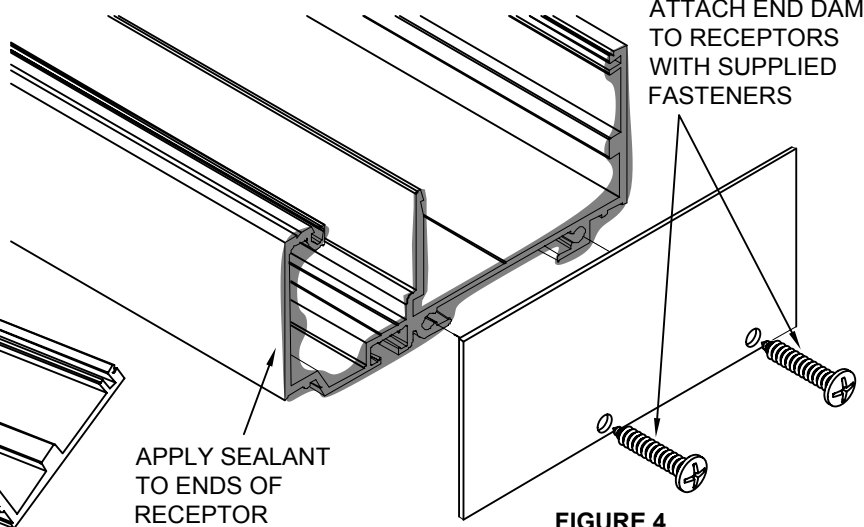

FIGURE 4

Laws and building and safety codes governing the design and use of glazed entrance, window, and curtain wall products vary widely. Kawneer does not control the selection of product configurations, operating hardware, or glazing materials, and assumes no responsibility therefor.

Kawneer reserves the right to change configuration without prior notice when deemed necessary for product improvement.

© Kawneer Company, Inc. 2009

- STEP A:** Cut jamb to required length.
- STEP B:** Prep for horizontals if required. Refer to pages 7 and 8 for locations.
- STEP C:** Drill two 0.147" dia holes for head anchor at the location shown.
- STEP D:** Drill two 0.147" dia holes for sill anchor at the location shown.
- STEP E:** Do not attach anchors at this time. The anchors are shown in the illustrations below for reference only.

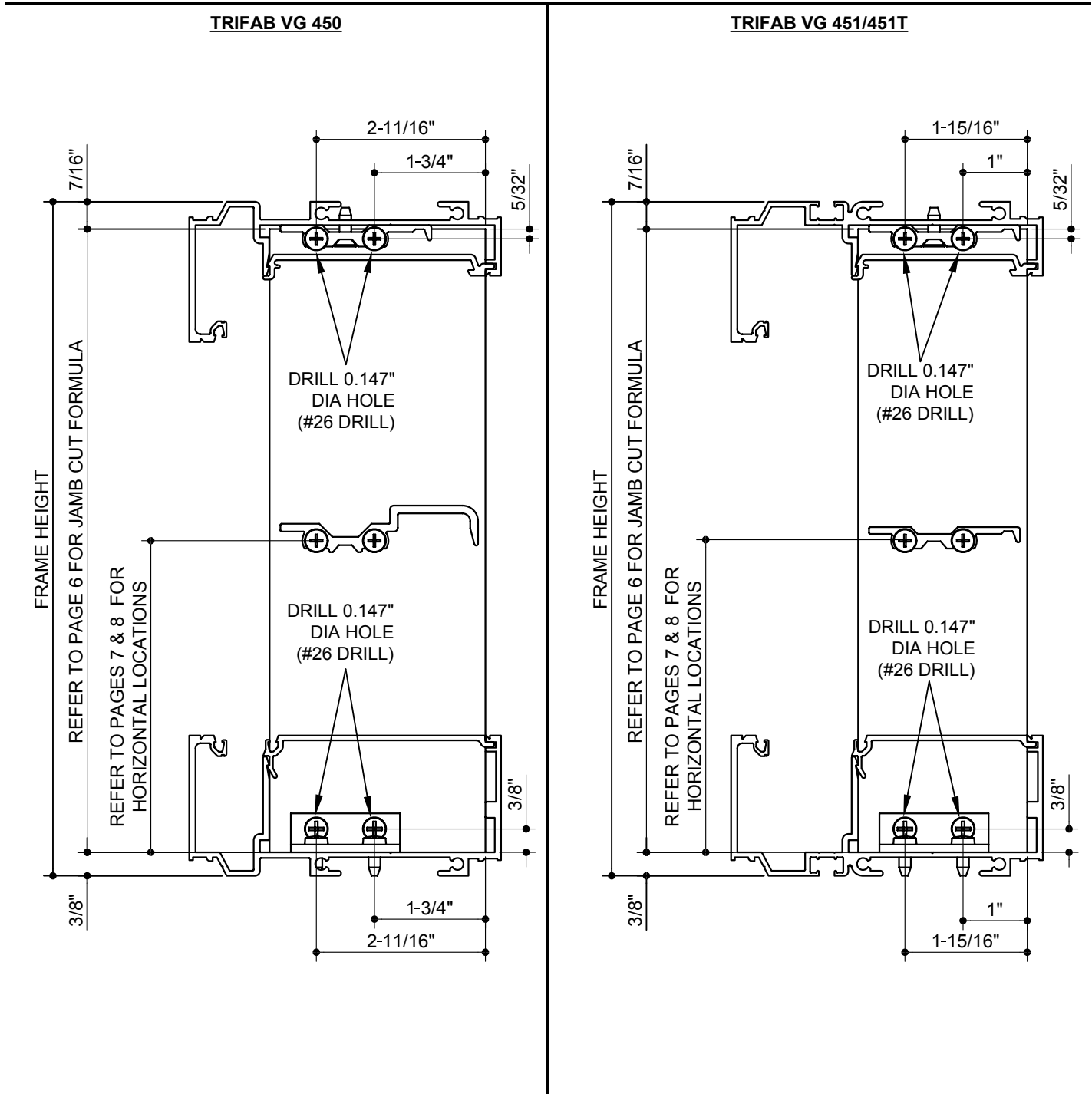

Laws and building and safety codes governing the design and use of glazed entrance, window, and curtain wall products vary widely. Kawneer does not control the selection of product configurations, operating hardware, or glazing materials, and assumes no responsibility therefor.

Kawneer reserves the right to change configuration without prior notice when deemed necessary for product improvement.
© Kawneer Company, Inc. 2009

- STEP A:** Cut mullion halves to required length (Refer to page 6 for lengths).
- STEP B:** Fabricate horizontals as shown on page 12.
- STEP C:** Cut outside glazed glass stops to length (Refer to page 6). Miter inside glaze glass stop as shown on page 12.
- STEP D:** Drill mullion halves for shear blocks as shown below. Use the actual fabricated clip as a template.
- STEP E:** Attach shear blocks using (2) 028-400 (#10 x 1-19/32") pan head screws.
- STEP F:** Fabricate horizontals for (1) 128-345 (#10 x 9/16") flat head screw as shown on page 12.

90° SSG DART CORNERS

NOTE:
BACK TO BACK 90° OR 135°
DART CORNERS UNIT MUST
BE OUTSIDE GLAZED.

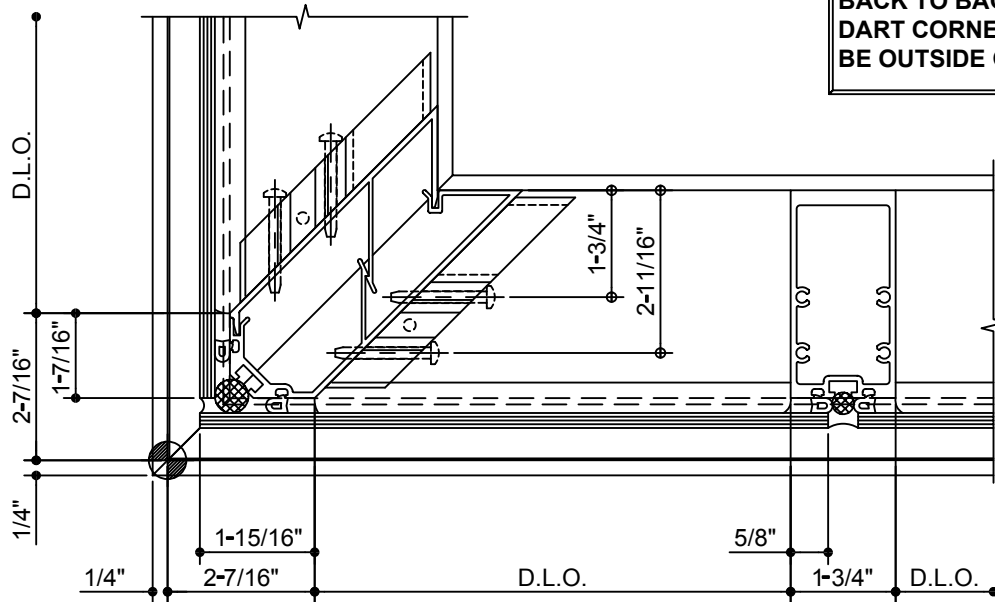

135° SSG DART CORNERS

NOTE:
BACK TO BACK 90° OR 135°
DART CORNERS UNIT MUST
BE OUTSIDE GLAZED.

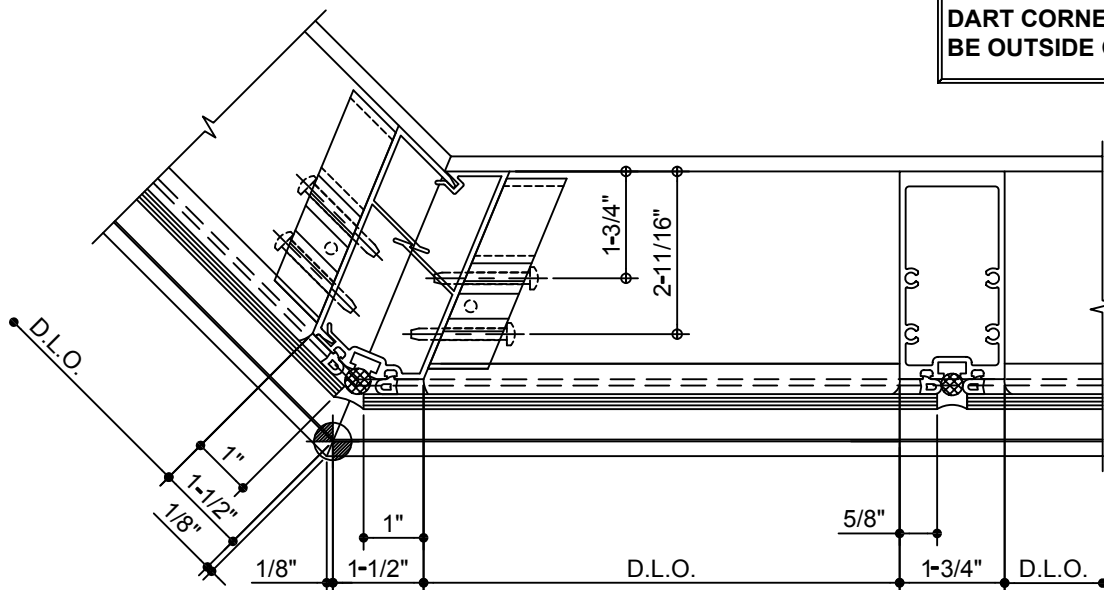

Laws and building and safety codes governing the design and use of glazed entrance, window, and curtain wall products vary widely. Kawneer does not control the selection of product configurations, operating hardware, or glazing materials, and assumes no responsibility therefor.

Kawneer reserves the right to change configuration without prior notice when deemed necessary for product improvement.
© Kawneer Company, Inc. 2009

HORIZONTAL PREPS FOR 90° DART CORNERS

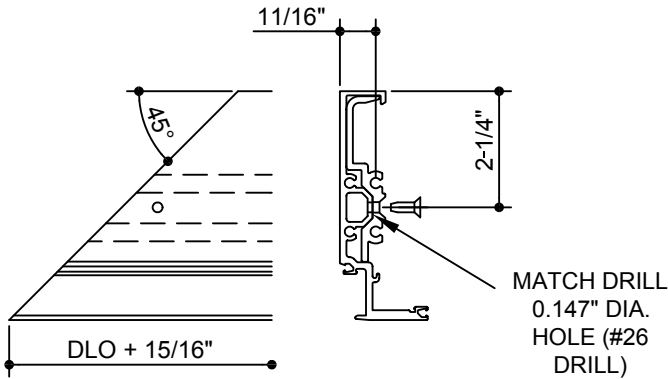

HEAD/SILL INSERT PREPS FOR 90° DART CORNERS

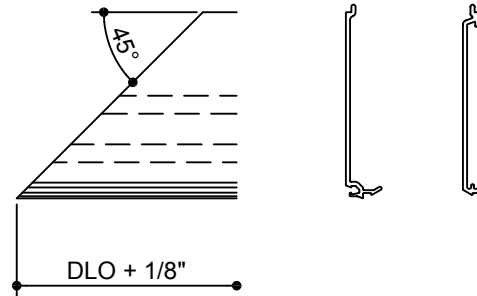

HORIZONTAL PREPS FOR 135° DART CORNERS

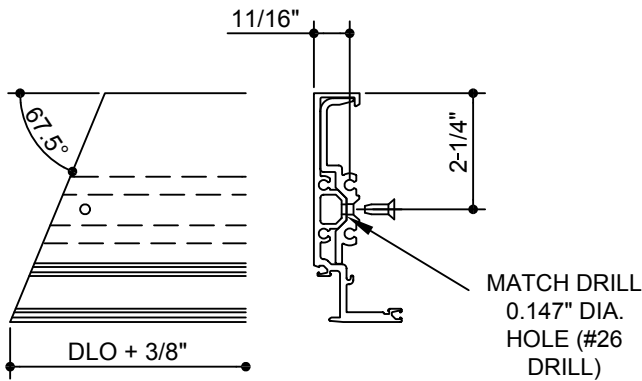

HEAD/SILL INSERT PREPS FOR 135° DART CORNERS

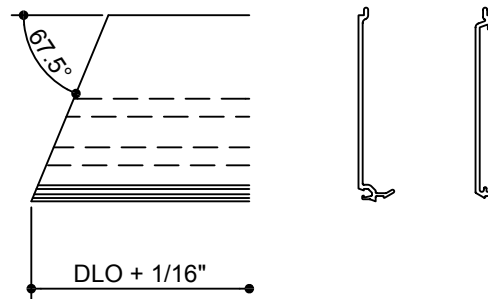

90° GLASS STOP PREPS

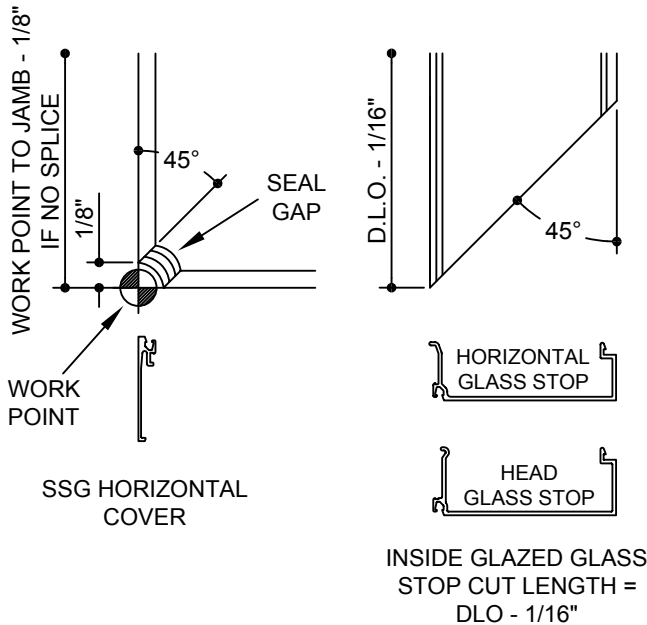

135° GLASS STOP PREPS

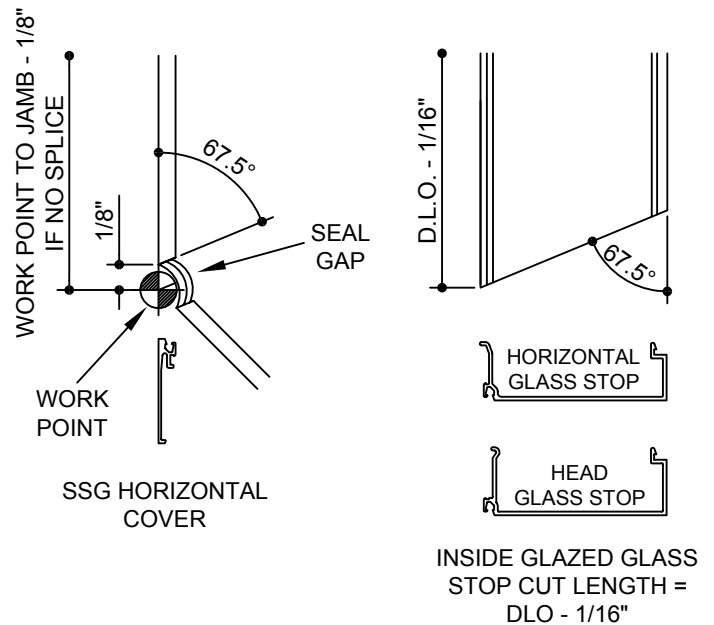

Laws and building and safety codes governing the design and use of glazed entrance, window, and curtain wall products vary widely. Kawneer does not control the selection of product configurations, operating hardware, or glazing materials, and assumes no responsibility therefor.

Kawneer reserves the right to change configuration without prior notice when deemed necessary for product improvement.

© Kawneer Company, Inc. 2009

- STEP A:** Cut mullion halves to required length (Refer to page 6 for lengths).
- STEP B:** Fabricate horizontals as shown on page 14.
- STEP C:** Cut outside glazed glass stops to length (Refer to page 6). Miter inside glaze glass stop as shown on page 14.
- STEP D:** Drill mullion halves for shear blocks as shown below. Use the actual fabricated clip as a template.
- STEP E:** Attach shear blocks using (2) 028-400 (#10 x 1-19/32") pan head screws.
- STEP F:** Fabricate horizontals for (1) 128-345 (#10 x 9/16") flat head screw as shown on page 14.

90° SSG DART CORNERS

NOTE:
BACK TO BACK 90° OR 135°
DART CORNERS UNIT MUST
BE OUTSIDE GLAZED.

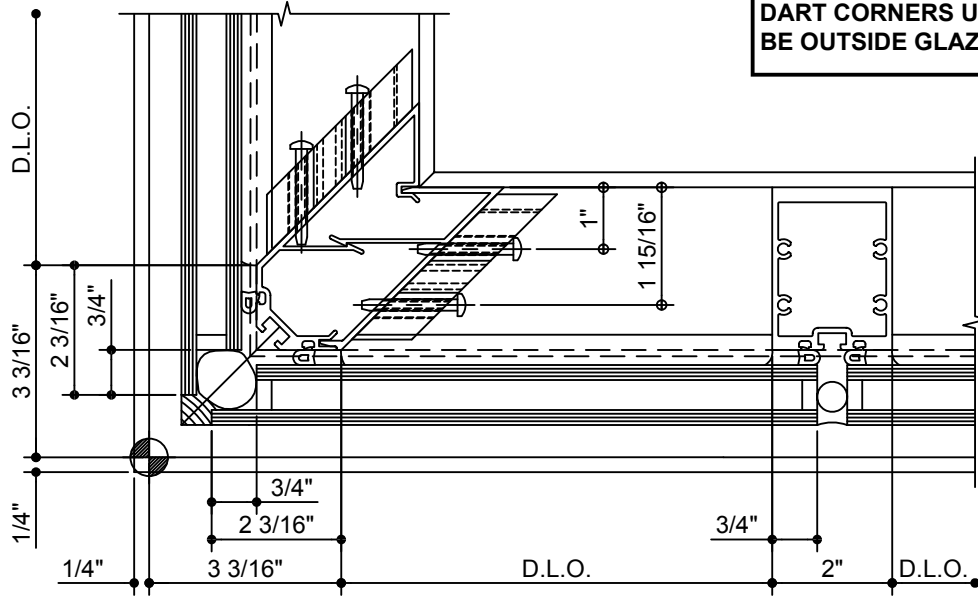

135° SSG DART CORNERS

NOTE:
BACK TO BACK 90° OR 135°
DART CORNERS UNIT MUST
BE OUTSIDE GLAZED.

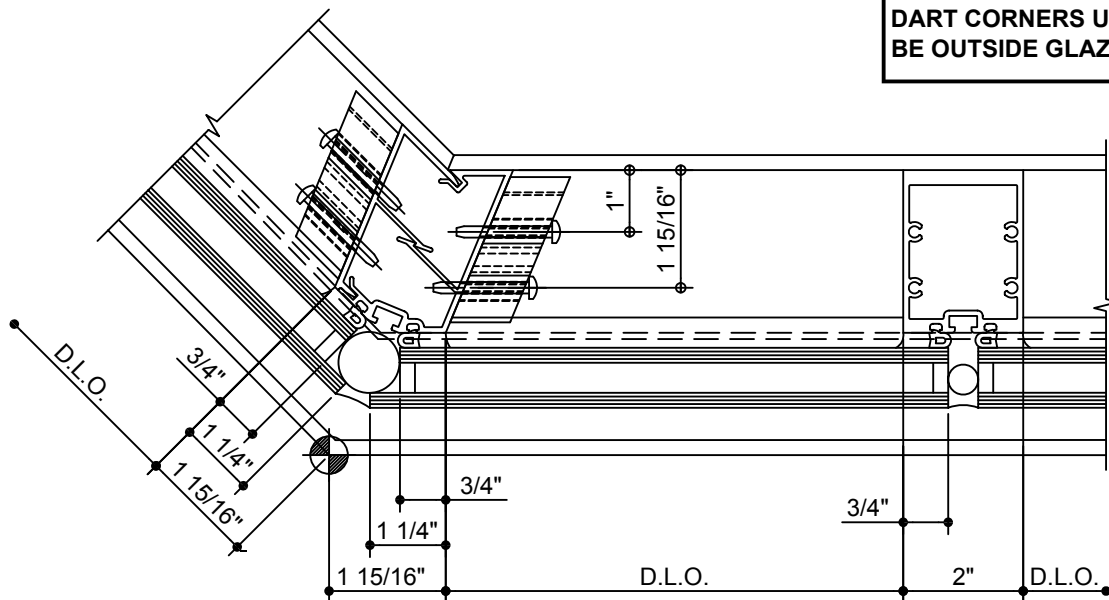

Laws and building and safety codes governing the design and use of glazed entrance, window, and curtain wall products vary widely. Kawneer does not control the selection of product configurations, operating hardware, or glazing materials, and assumes no responsibility therefor.

Kawneer reserves the right to change configuration without prior notice when deemed necessary for product improvement.

© Kawneer Company, Inc. 2009

HORIZONTAL PREPS FOR 90° DART CORNERS

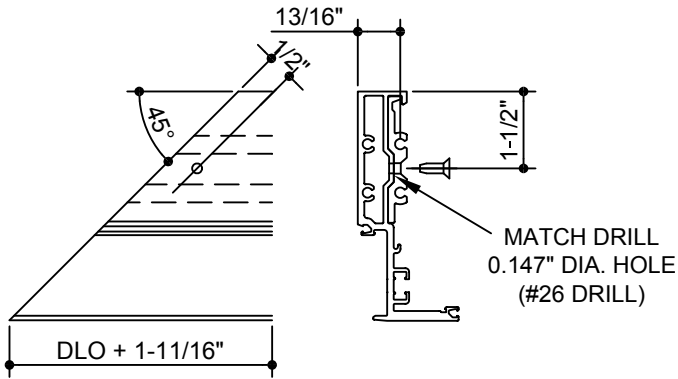

HEAD/SILL INSERT PREPS FOR 90° DART CORNERS

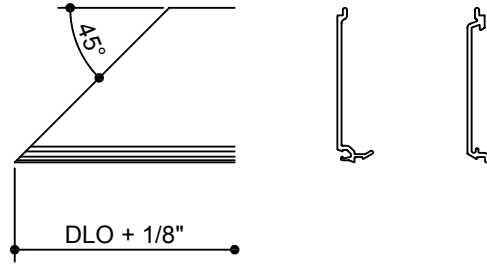

HORIZONTAL PREPS FOR 135° DART CORNERS

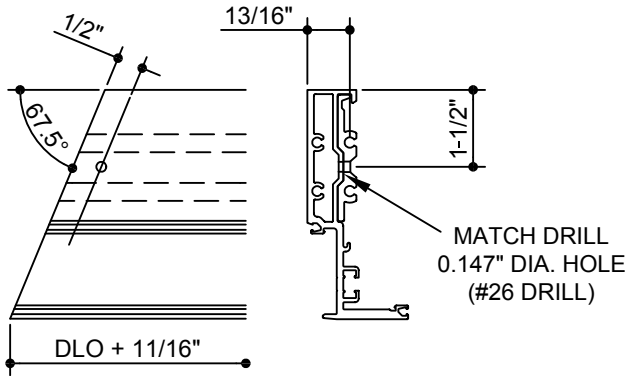

HEAD/SILL INSERT PREPS FOR 135° DART CORNERS

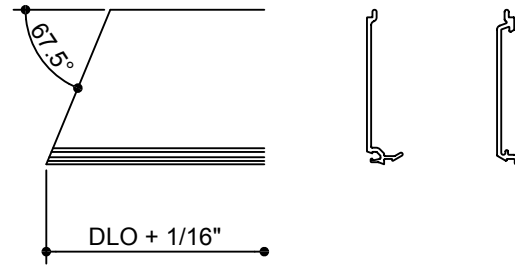

90° GLASS STOP PREPS

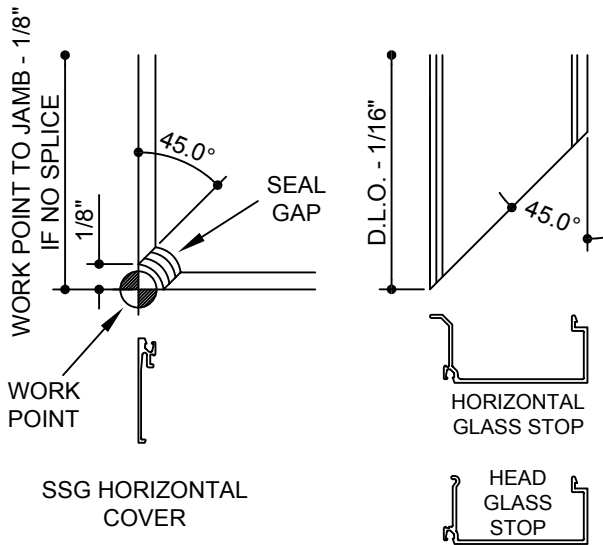

INSIDE GLAZED GLASS STOP CUT LENGTH = DLO - 1/16"

135° GLASS STOP PREPS

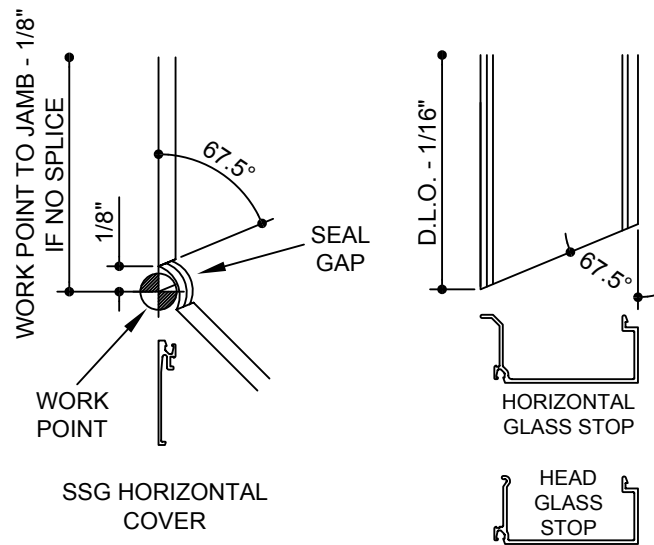

INSIDE GLAZED GLASS STOP CUT LENGTH = DLO - 1/16"

Laws and building and safety codes governing the design and use of glazed entrance, window, and curtain wall products vary widely. Kawneer does not control the selection of product configurations, operating hardware, or glazing materials, and assumes no responsibility therefor.

Kawneer reserves the right to change configuration without prior notice when deemed necessary for product improvement.

© Kawneer Company, Inc. 2009

- STEP A:** Install Head and Sill receptors level and true in opening. The sill receptor should be shimmed up a minimum of 1/4" as required at each fastener and under the location of each mullion to level receptor. Seal the ends of the Head and Sill receptor and seal over all fasteners at sill. (Figure 1)
- STEP B:** Install anchors onto jamb. Refer to page 10 for jamb fabrication instructions. Install the jamb and plumb as required. No perimeter anchors are required along jamb member. (Figure 2)
- STEP C:** Apply sealant along face and into the reglets of the jamb and top of receptor leg at the head and sill as shown. (Figure 2)
- STEP D:** Apply sealant along jamb between the head and sill receptors as shown. (Figure 2 and 3)
- STEP E:** Install Jamb adaptor inserting leg into center reglet of jamb and rotating until it bottoms out on the jamb member. Fasten with 028-259 (#8 x 5/8" PHTF "AB") screws. (Figure 4)
- STEP F:** Once jamb adaptor has been installed, apply sealant at the joint of the jamb adaptor and glazing reglet of the receptor at the head and sill conditions. (Figure 5)
- STEP G:** Snap in head and sill inserts tight against jamb member using a mallet and a block of wood to prevent denting of inserts. Tight snaps may be waxed to make engagement easier. **Head and sill inserts are not designed to be unsnapped.**
- STEP H:** Tip mullion into place in the head and sill channels. Tap mullion toward head and sill inserts to get a tight joint.
- STEP I:** Continue with Steps H and I until final bay. At the last bay, the head and sill inserts **should not** be snapped into place until the jamb is installed.
- STEP J:** Install the final jamb following **Steps B thru F**. Snap in the last head and sill inserts.

NOTE:
 IF THERE IS AN ENTRANCE,
 BEGIN INSTALLATION AT THE
 DOOR JAMB. IF THERE ARE
 CORNERS, START AT CORNERS
 AND WORK TOWARD OTHER
 ENDS.

APPLY & TOOL SEALANT
 ALONG JOINT BETWEEN
 END DAM AND RECEPTOR

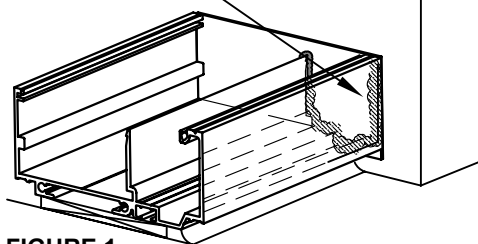
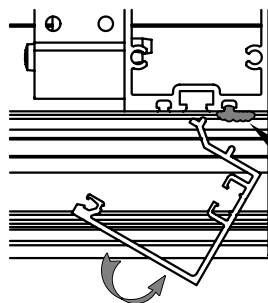

FIGURE 1



APPLY
 SEALANT
 ALONG
 JAMB

FIGURE 3

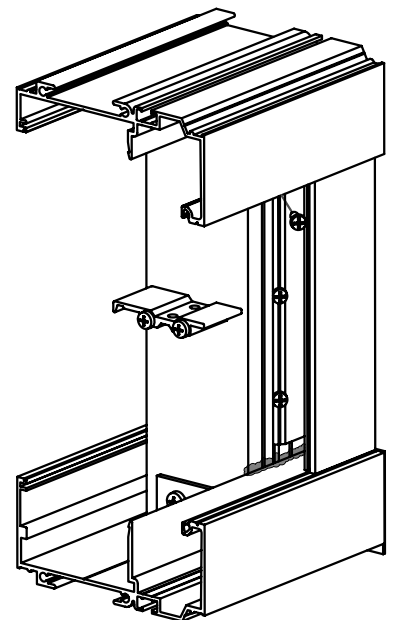

FIGURE 4

APPLY & TOOL
 SEALANT ALONG
 EDGE OF JAMB
 AND SILL
 RECEPTOR AND
 INTO GLAZING
 POCKETS

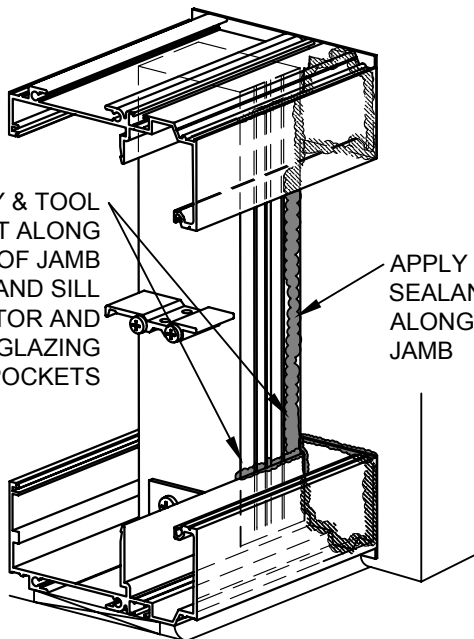

FIGURE 2

APPLY
 SEALANT
 ALONG
 JAMB

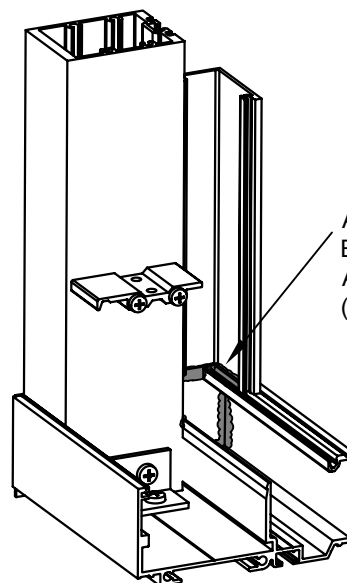

FIGURE 5

APPLY SEALANT
 BETWEEN RECEPTOR
 AND JAMB ADAPTOR
 (AT HEAD AND SILL)

Laws and building and safety codes governing the design and use of glazed entrance, window, and curtain wall products vary widely. Kawneer does not control the selection of product configurations, operating hardware, or glazing materials, and assumes no responsibility therefor.

Kawneer reserves the right to change configuration without prior notice when deemed necessary for product improvement.
 © Kawneer Company, Inc. 2009

- STEP A:** Apply bond breaker tape to bottom of aluminum splice sleeve as shown. (Figure 1)
- STEP B:** Apply heavy bead of silicone sealant on one receptor and bead of non-skinning, non-hardening sealant on the other receptor. Install splice sleeve so that bond breaker tape aligns with splice joint as shown. (Figure 2)
- STEP C:** Pin splice sleeve on the side with the silicone joint and seal over heads of pins. Apply a secondary silicone seal on the pinned side as shown. (Figure 3)

NOTE: DO NOT PIN THRU THERMAL BREAK

- STEP D:** Apply bond breaker tape over the joint between the splice and receptor on the bead of non-skinning, non-hardening sealant side of splice. (Figure 3) Apply silicone sealant over the bond breaker tape to create a water tight joint as shown. (Figure 4)

NOTES:
SPLICE SLEEVES SHOULD BE INSTALLED EVERY 12' WHEN RECEPTORS ARE OVER 24'. SPLICE SLEEVES ARE TO BE LOCATED AT THE CENTER OF A DLO.

DO NOT LOCATE SPLICE SLEEVES AT MULLIONS.

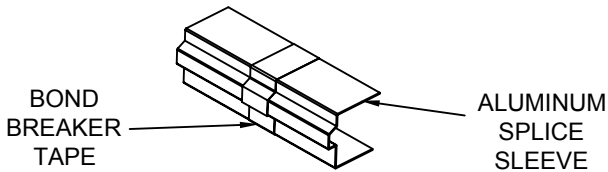

FIGURE 1

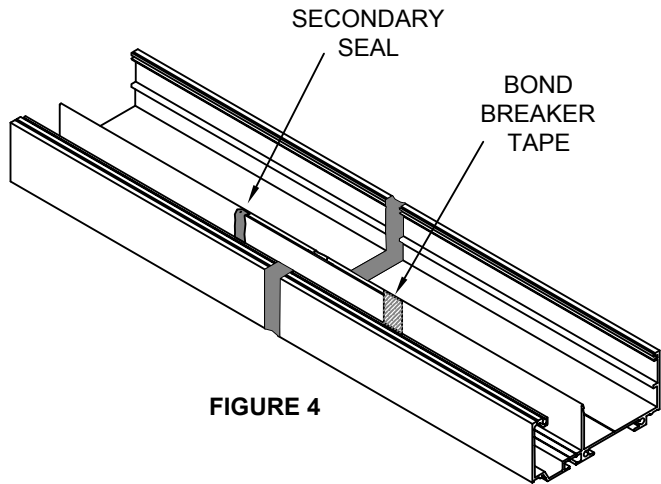

FIGURE 4

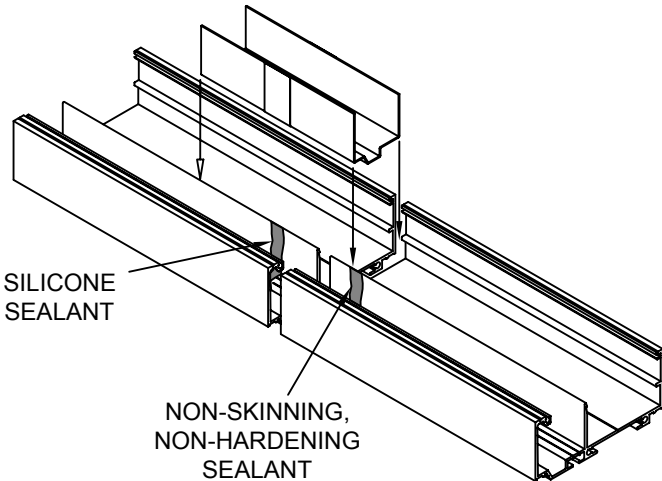

FIGURE 2

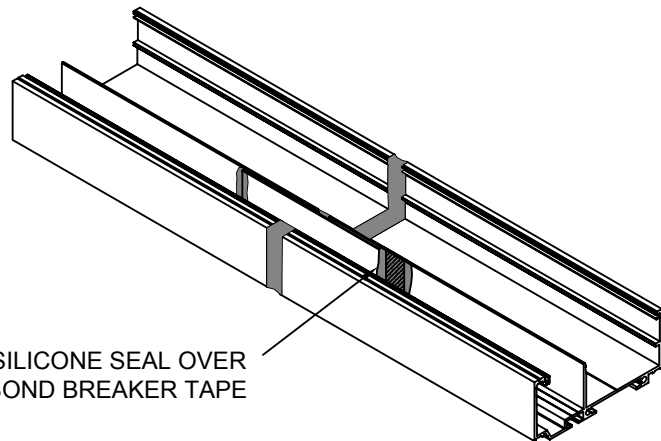

FIGURE 5

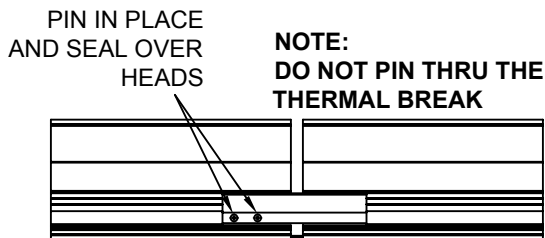

FIGURE 3

Laws and building and safety codes governing the design and use of glazed entrance, window, and curtain wall products vary widely. Kawneer does not control the selection of product configurations, operating hardware, or glazing materials, and assumes no responsibility therefor.

Kawneer reserves the right to change configuration without prior notice when deemed necessary for product improvement.
 © Kawneer Company, Inc. 2009

- STEP A:** Miter two 16" sections of Head and Sill receptors to correct angle.
- STEP B:** Drill two 0.201" DIA clear holes with a #1 drill bit in each mitered section at the locations shown on pages 19.
- STEP C:** Locate the corner plate under the mitered section. Match drill with #11 (0.191" dia hole) drill bit and fasten with 028-312 (#12 x 1/2" PHTF "AB") screws. (Figure 1)
- STEP D:** Apply sealant to end of the mitered section and over the heads of the fasteners. (Figure 2)
- STEP E:** Place the other mitered section on the corner plate and fasten with supplied screws. Seal over heads of fasteners. (Figure 3)
- STEP F:** Apply sealant to the front and back upturned legs of the receptor and also along the bottom of the receptors at the mitered joint. Tool as required. (Figure 4)

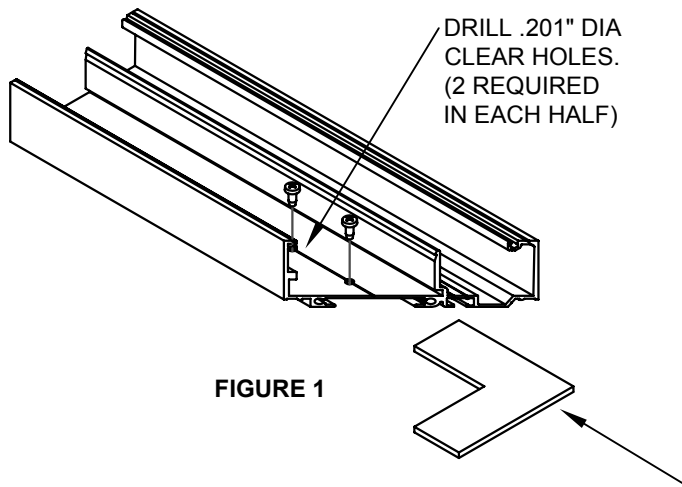

FIGURE 1

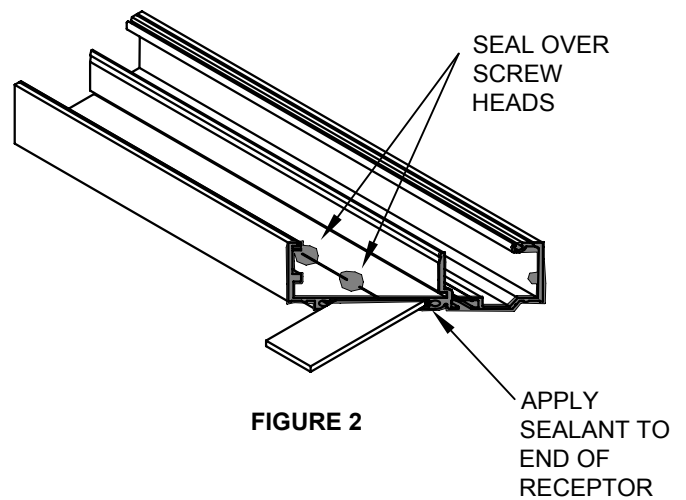

FIGURE 2

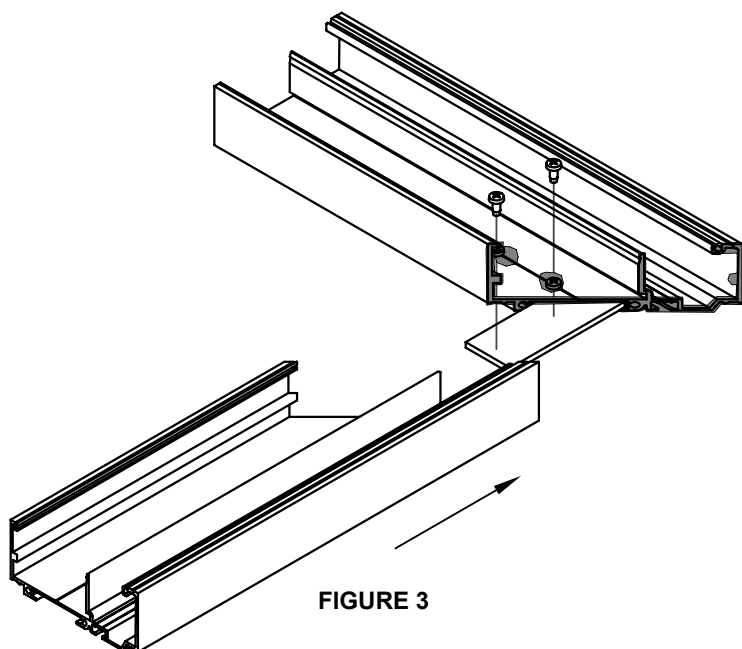

FIGURE 3

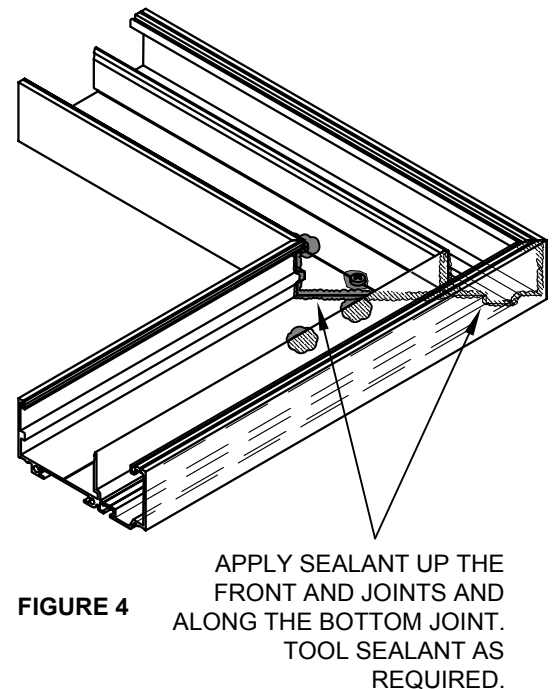

FIGURE 4

Laws and building and safety codes governing the design and use of glazed entrance, window, and curtain wall products vary widely. Kawneer does not control the selection of product configurations, operating hardware, or glazing materials, and assumes no responsibility therefor.

Kawneer reserves the right to change configuration without prior notice when deemed necessary for product improvement.
© Kawneer Company, Inc. 2009

- STEP A:** Set Prefabricated Corner in a bed of sealant, level, and securely anchor into place. Refer to shop drawings or consult a structural engineer for anchoring requirements.
- STEP B:** Completely seal non-moving mitered joint and fastener heads.
- STEP C:** Install 12 foot lengths of receptor on either side of corner leaving 1/2" gap between for expansion.
- STEP D:** Install splice sleeves. Refer to page 16 for splice sleeve installation instructions.

NOTE:
REFER TO SHOP DRAWINGS OR CONSULT A STRUCTURAL ENGINEER FOR PERIMETER ANCHORING REQUIREMENTS

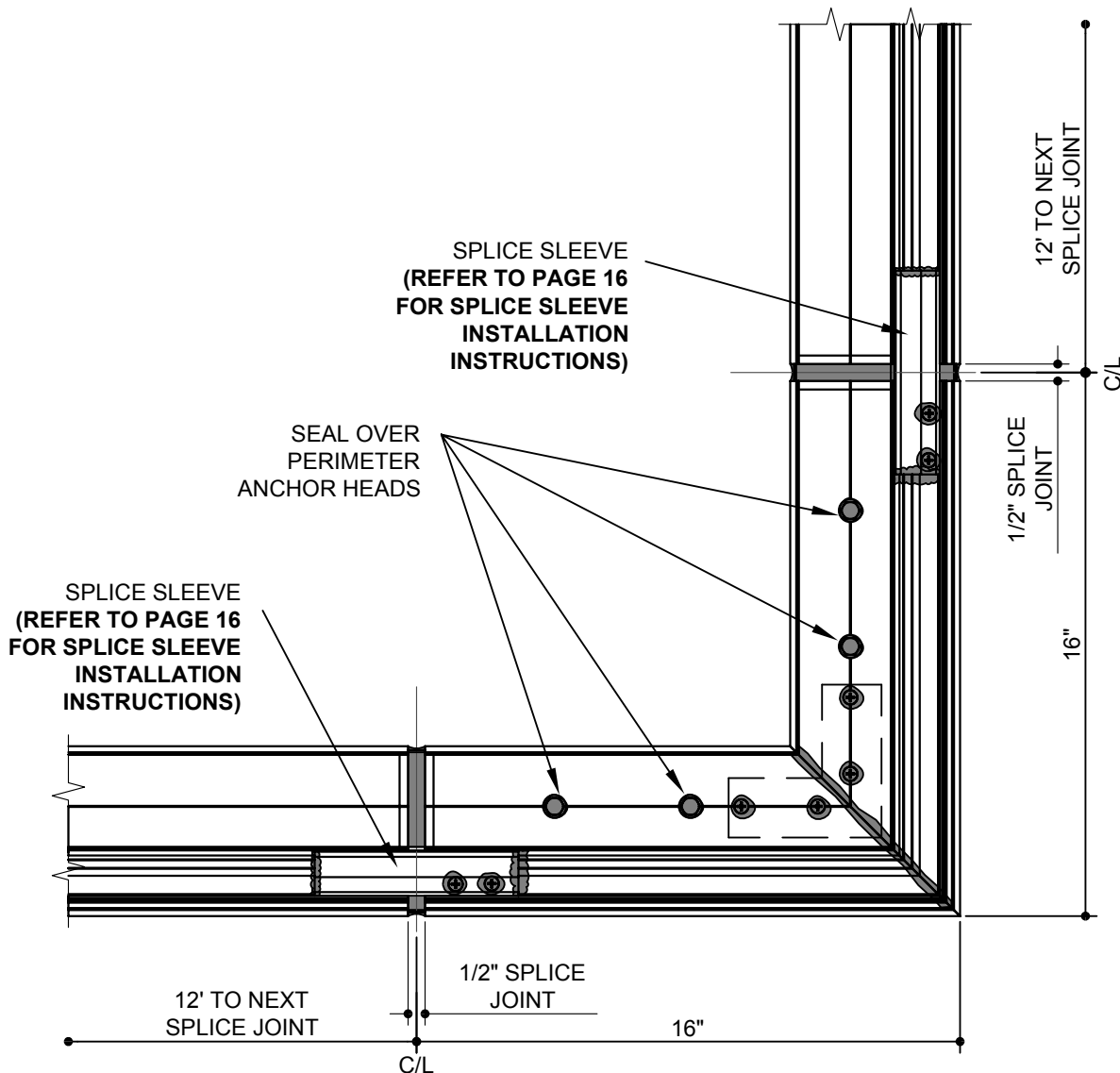

Laws and building and safety codes governing the design and use of glazed entrance, window, and curtain wall products vary widely. Kawneer does not control the selection of product configurations, operating hardware, or glazing materials, and assumes no responsibility therefor.

Kawneer reserves the right to change configuration without prior notice when deemed necessary for product improvement.

© Kawneer Company, Inc. 2009

90° OUTSIDE CORNER

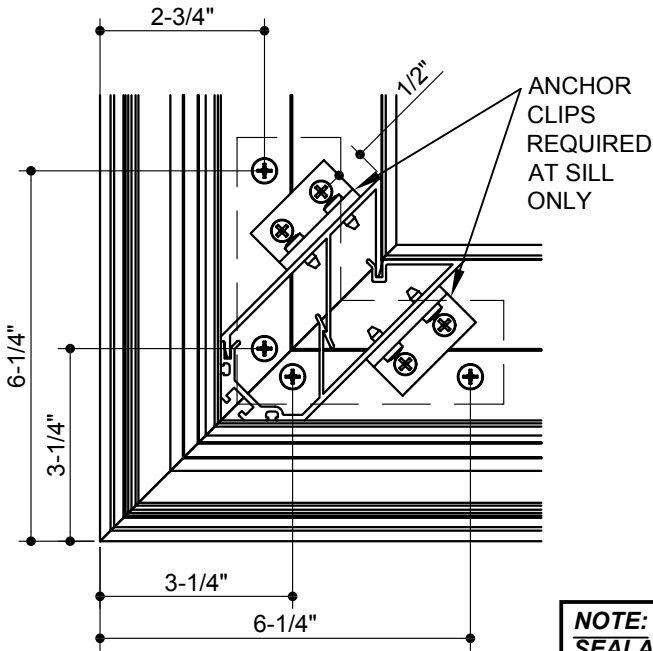

135° OUTSIDE CORNER

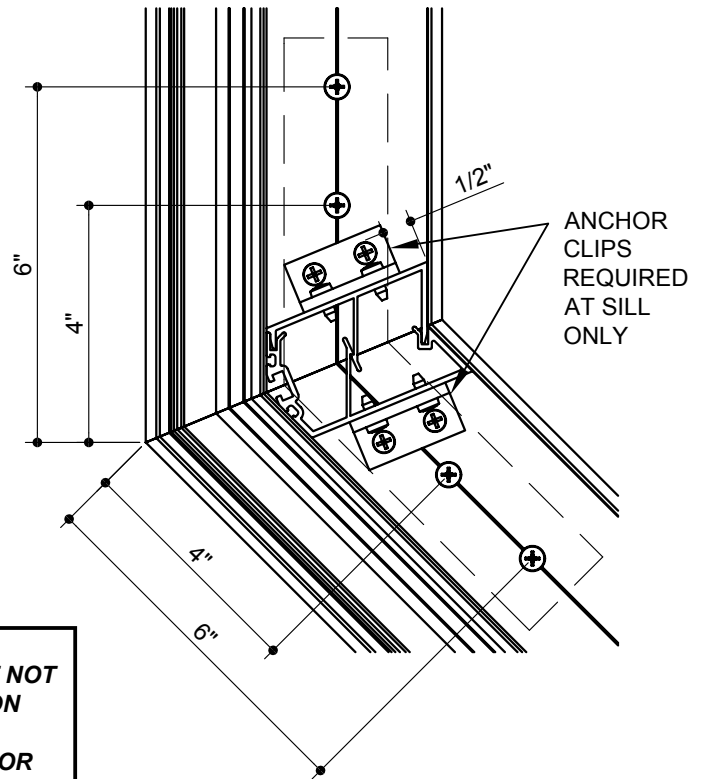

NOTE:
SEALANT NOT SHOWN ON DETAILS BELOW FOR CLARITY.

90° INSIDE CORNER

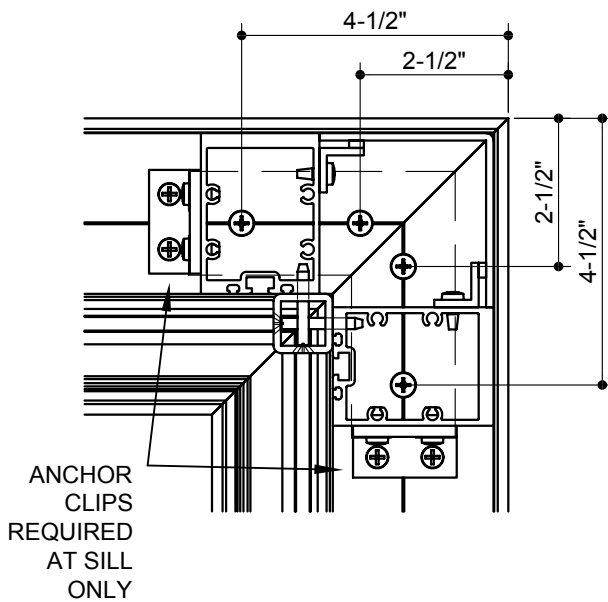

135° INSIDE CORNER

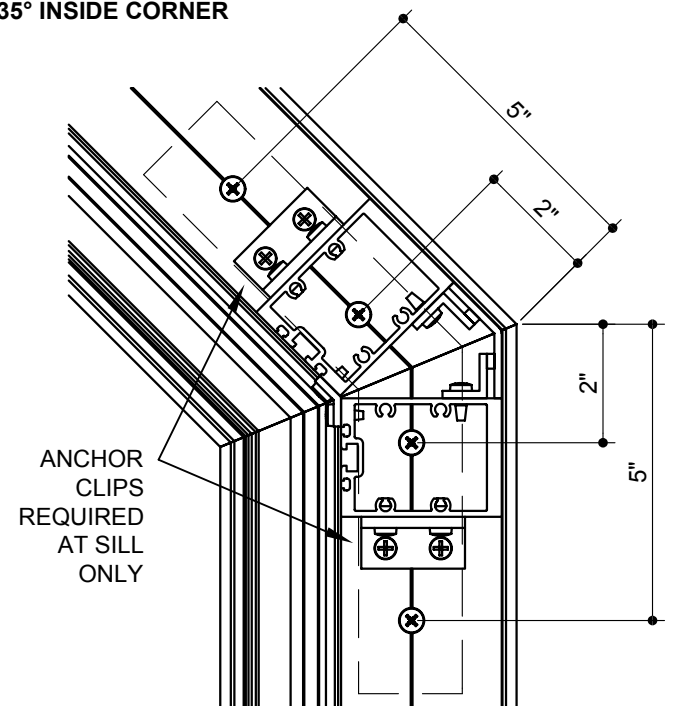

Laws and building and safety codes governing the design and use of glazed entrance, window, and curtain wall products vary widely. Kawneer does not control the selection of product configurations, operating hardware, or glazing materials, and assumes no responsibility therefor.

Kawneer reserves the right to change configuration without prior notice when deemed necessary for product improvement.

© Kawneer Company, Inc. 2009

**NOTE: 90° CORNER SHOWN,
135° CORNER SIMILAR**

- STEP A:** Install female dart corner half into head and sill receptors and position in corner. Do not damage the sill receptor splice joint. (Figure 1)
- STEP C:** Install male half of dart corner mullion. (Figure 2)
- STEP D:** Locate angle clips at bottom of each side of dart corner mullion. Match drill holes and fasten with supplied screws. (Figure 2)
- STEP E:** Apply sealant to corner where the mullion meets the receptor. Seal over heads of angle clip fasteners. Tool all sealant. (Figure 2 and 3)

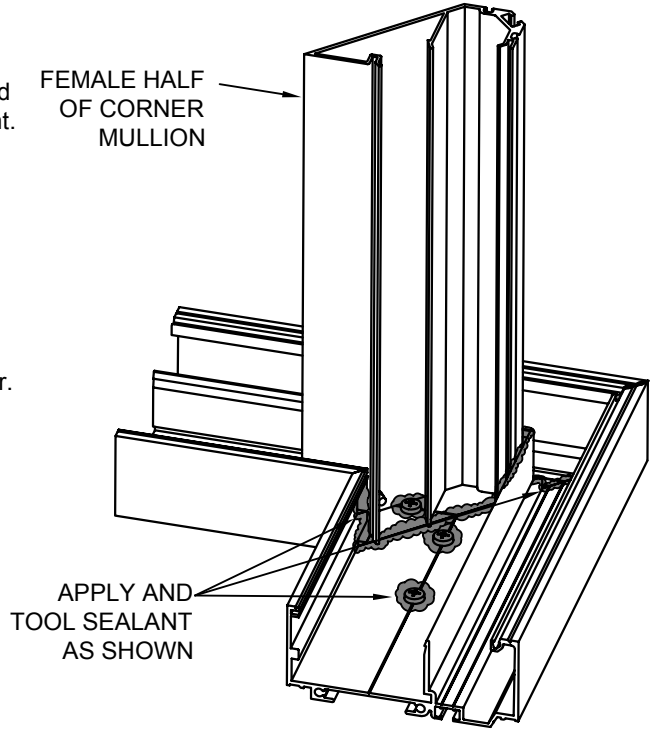

FIGURE 1

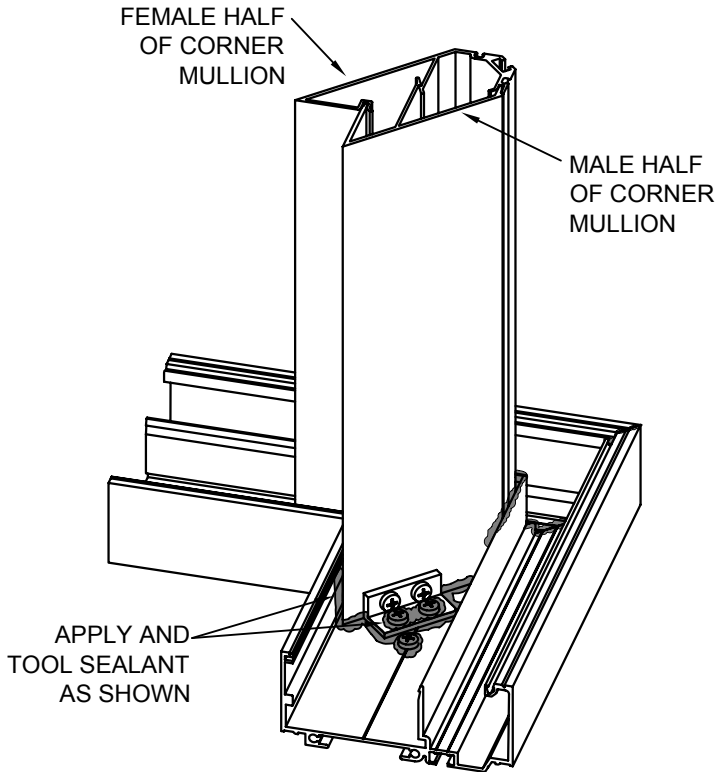

FIGURE 2

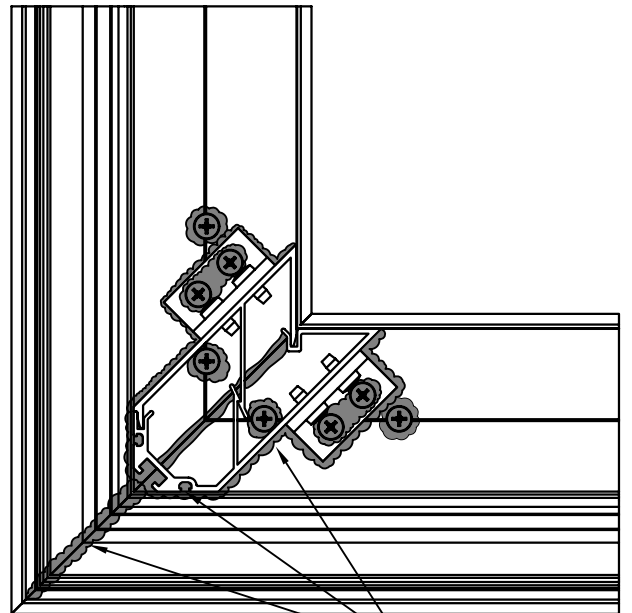

FIGURE 3

Laws and building and safety codes governing the design and use of glazed entrance, window, and curtain wall products vary widely. Kawneer does not control the selection of product configurations, operating hardware, or glazing materials, and assumes no responsibility therefor.

Kawneer reserves the right to change configuration without prior notice when deemed necessary for product improvement.
© Kawneer Company, Inc. 2009

Steel reinforcement should be cut to mullion length minus 12" and fastened into place to prevent movement of the steel in the mullion. Position steel 6" from top of mullion and 6" from bottom of mullion, providing room for the mullion anchors. The cut ends of the steel reinforcing must be coated with a corrosion-inhibiting primer before installation.

NOTE:
CONSULT APPLICATION
ENGINEERING FOR PROPER
STEEL SIZE & ATTACHMENT
PER JOB REQUIREMENTS.

LOCATE FASTENER
(#10-24 x 3/8" FHMS)
AT CENTER OF
MULLION LENGTH.

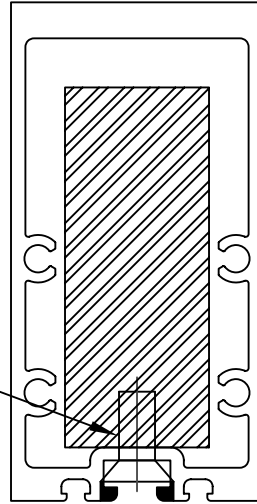

450 SSG TUBE MULLION
WITH 1" X 2-1/2" STEEL BAR
REINFORCING

LOCATE FASTENER
(#10-24 x 3/8" FHMS)
AT CENTER OF
MULLION LENGTH.

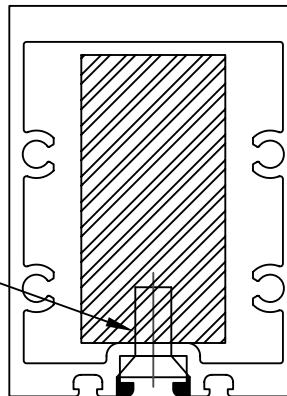

451/451T SSG TUBE MULLION
WITH 1" X 2" STEEL BAR
REINFORCING

Laws and building and safety codes governing the design and use of glazed entrance, window, and curtain wall products vary widely. Kawneer does not control the selection of product configurations, operating hardware, or glazing materials, and assumes no responsibility therefor.

Kawneer reserves the right to change configuration without prior notice when deemed necessary for product improvement.

© Kawneer Company, Inc. 2009

STEP A: Mullion anchors are installed after the head and sill receptors have been installed. Anchors are placed in the receptor after adjacent inserts have been installed and twisted to lock them into place. (Figure 1 and 2)

STEP B: Install the head mullion anchor.

STEP C: Install the sill mullion anchor.

STEP D: Position the mullion onto the sill anchor first. While tilting the mullion up, slide the head anchor into the top of the mullion.

STEP E: Install head and sill inserts. Repeat STEP D and E until all mullions have been installed.

NOTE:
CONSULT APPLICATION
ENGINEERING FOR MULLION
ANCHOR REQUIREMENTS.

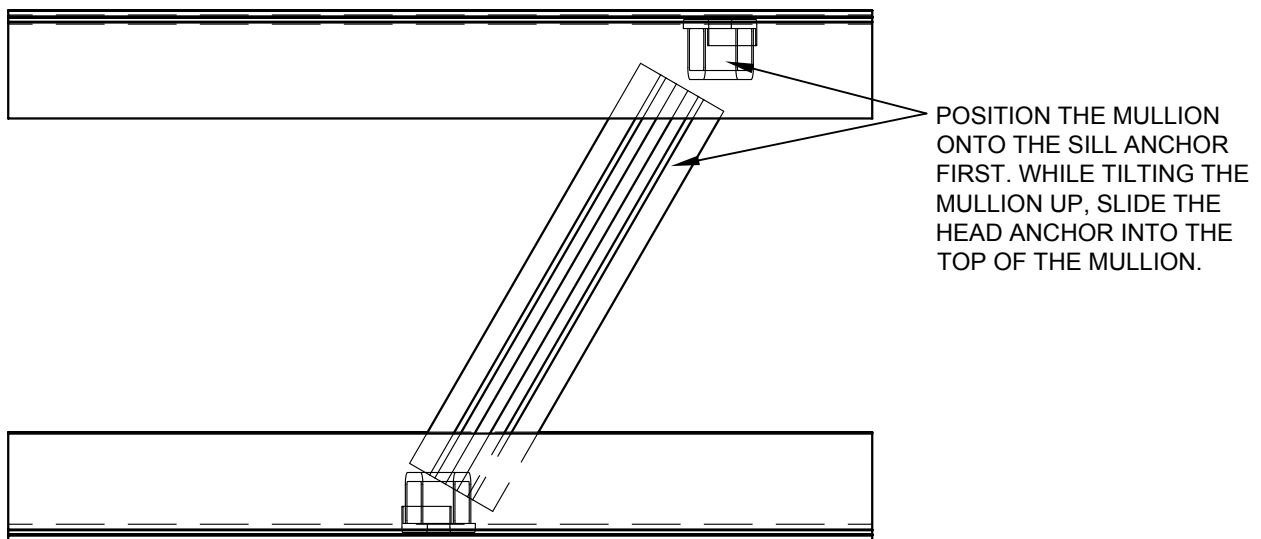
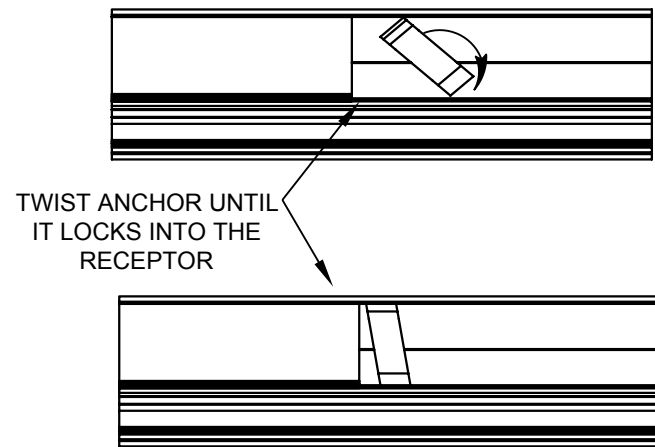
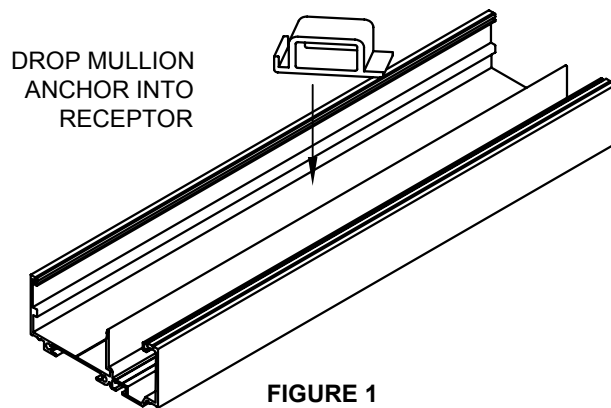

FIGURE 3

Laws and building and safety codes governing the design and use of glazed entrance, window, and curtain wall products vary widely. Kawneer does not control the selection of product configurations, operating hardware, or glazing materials, and assumes no responsibility therefor.

Kawneer reserves the right to change configuration without prior notice when deemed necessary for product improvement.
© Kawneer Company, Inc. 2009

NOTE:
451/451T SHOWN,
450 SIMILAR

STEP A: Apply sealant to the ends of the horizontal members, shear blocks, and into glazing reglets. (Figure 1)

STEP B: Roll horizontal member over shear block. Hold fabricated horizontal member in place over shear block and tight against vertical member. Match drill tap hole in horizontal with #26 drill (0.147") slightly offset to D.L.O. side of hole in the shear block so as to pull the joint tight when assembled. (Figure 3)

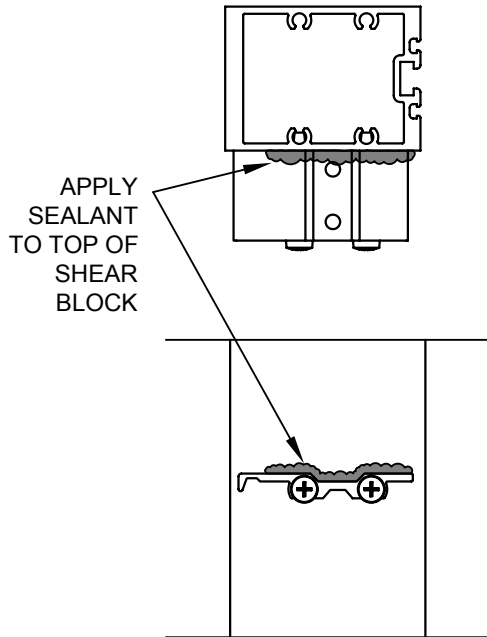

FIGURE 1

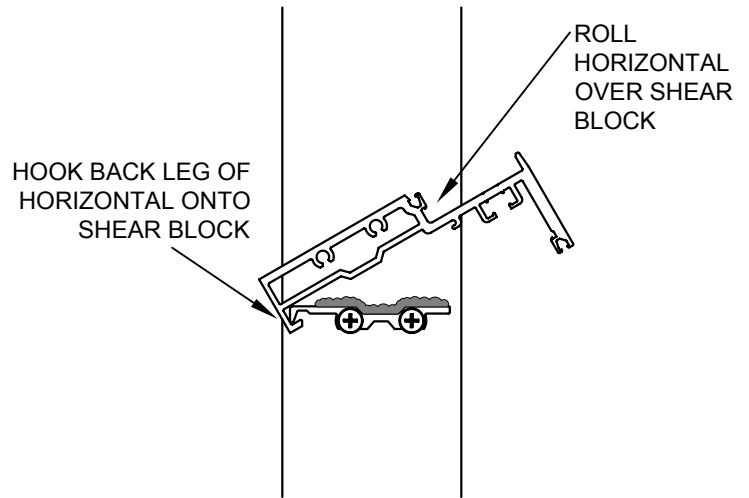

FIGURE 2

STEP C: Secure horizontal to shear block with supplied fasteners.

DRILL 0.147" DIA (#26 DRILL) HOLE TOWARD THE D.L.O. SIDE OF THE SHEAR BLOCK'S CLEARANCE HOLE

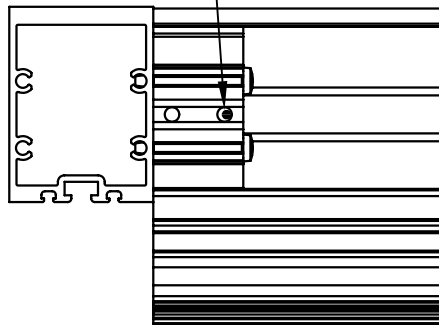

FIGURE 3

ATTACH HORIZONTAL TO SHEAR BLOCK WITH SUPPLIED FASTENER

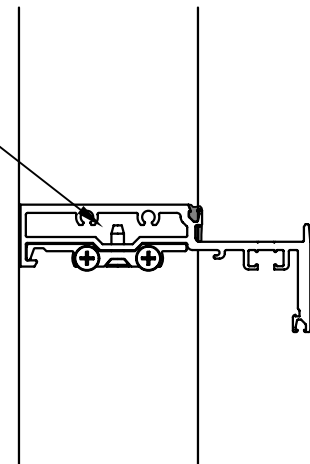

FIGURE 4

Laws and building and safety codes governing the design and use of glazed entrance, window, and curtain wall products vary widely. Kawneer does not control the selection of product configurations, operating hardware, or glazing materials, and assumes no responsibility therefor.

Kawneer reserves the right to change configuration without prior notice when deemed necessary for product improvement.
© Kawneer Company, Inc. 2009

Install water deflectors on Intermediate Horizontals by removing the paper backing from the water deflectors. Install on a clean, dry surface centered in the glazing pocket and seal. (Figure 1) Be sure to extend Water Deflector past glass edge below. (Figure 2)

NOTE: 451 \ 451T SHOWN, 450 SIMILAR

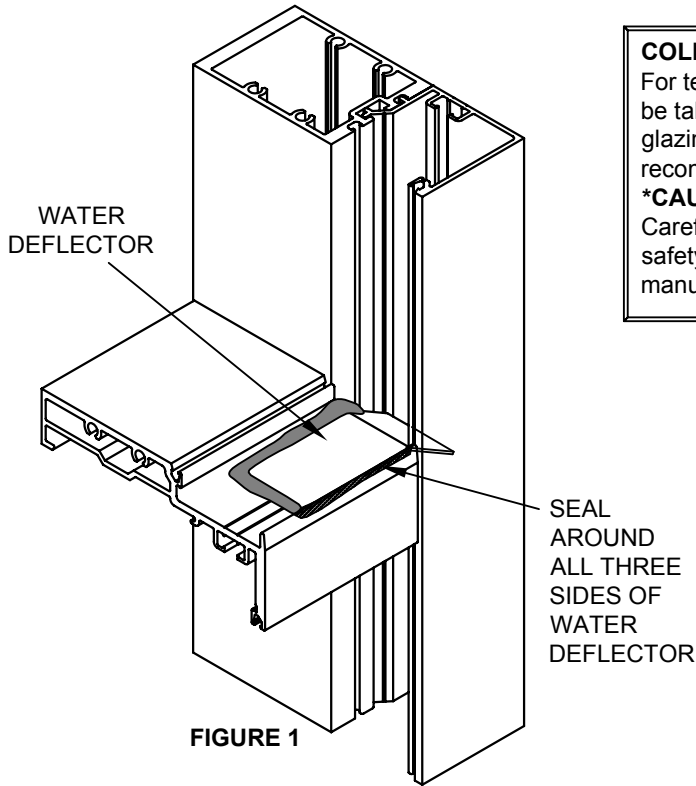

FIGURE 1

COLD WEATHER NOTE:
For temperatures below 40° the following precautions should be taken. Just prior to installing the water deflector, wipe glazing pocket with a solvent or cleaning solution recommended by the sealant manufacturer.
***CAUTION:**
Carefully follow the recommendations contained in the material safety data sheet provided by the solvent/cleaning solution manufacturer regarding health and fire/explosion risks.

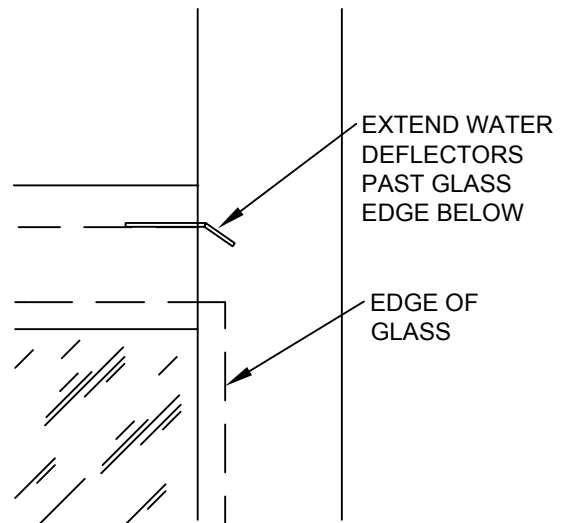

FIGURE 2

After the water deflector is installed, seal the joint between the back leg of the Horizontal and the Vertical. Make sure to fill the gasket reglets in the area to prevent water from running down to the lite below. (Figure 3 and 4)

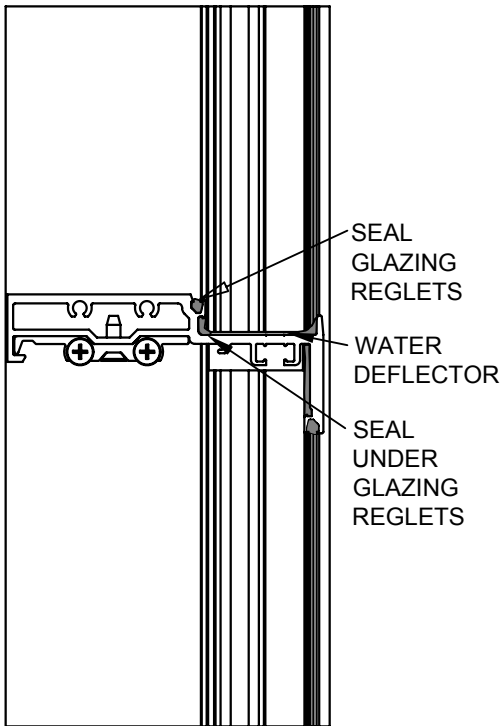

FIGURE 3

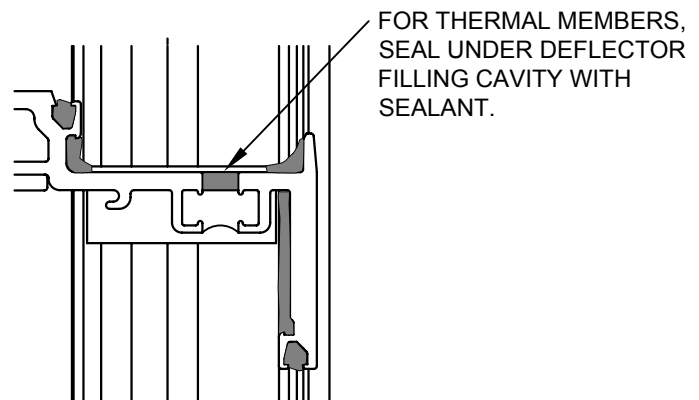

FIGURE 4

Laws and building and safety codes governing the design and use of glazed entrance, window, and curtain wall products vary widely. Kawneer does not control the selection of product configurations, operating hardware, or glazing materials, and assumes no responsibility therefor.

Kawneer reserves the right to change configuration without prior notice when deemed necessary for product improvement.
© Kawneer Company, Inc. 2009

NOTE:
451/451T SHOWN,
450 SIMILAR

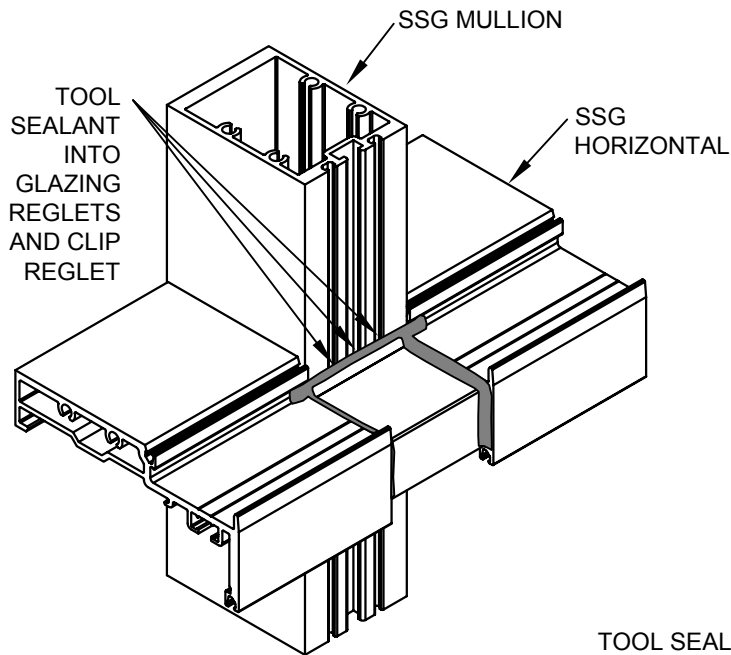

FIGURE 1
(1" OVER 1")

NOTE:
FOR WATER DEFLECTORS AT JAMBS,
REFER TO PAGE 24.

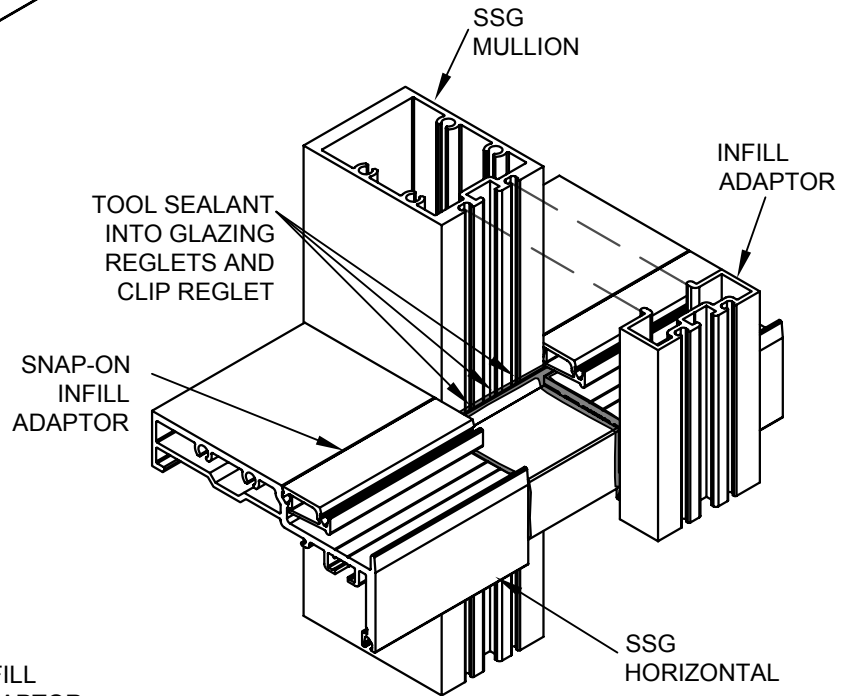

FIGURE 2
(1/4" OVER 1")

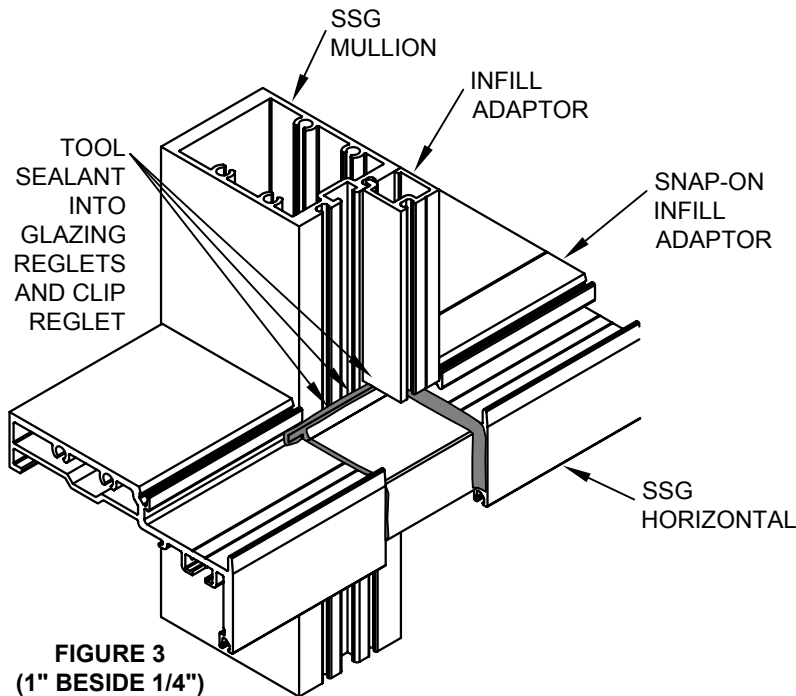

FIGURE 3
(1" BESIDE 1/4")

Laws and building and safety codes governing the design and use of glazed entrance, window, and curtain wall products vary widely. Kawneer does not control the selection of product configurations, operating hardware, or glazing materials, and assumes no responsibility therefor.

Kawneer reserves the right to change configuration without prior notice when deemed necessary for product improvement.

© Kawneer Company, Inc. 2009

ADJUSTABLE WATER DEFLECTOR FOR 450 SSG DART CORNER WITHOUT COVERS.

STEP A: Cut or bend along dividing line until rear half is broken off. (Figure 1)

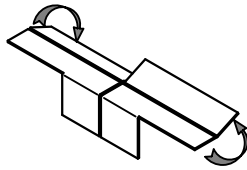

FIGURE 1

STEP B: Bend along dividing line on front face of water deflector to the required angle. One top side will have to be bent down slightly to let the other side fold over it. (Figure 3 and 4)

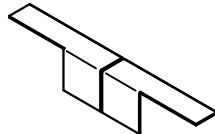

FIGURE 2

STEP C: Trial fit the modified water deflector and adjust if required.

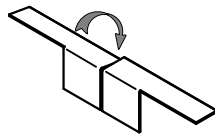

FIGURE 3

STEP D: Apply sealant around the top and down the sides of the water deflector and overlap area. Also apply sealant in the glazing reglets and clip reglets. Tool sealant. (Figure 5)

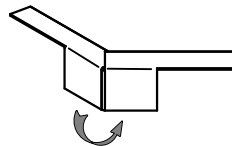

FIGURE 4

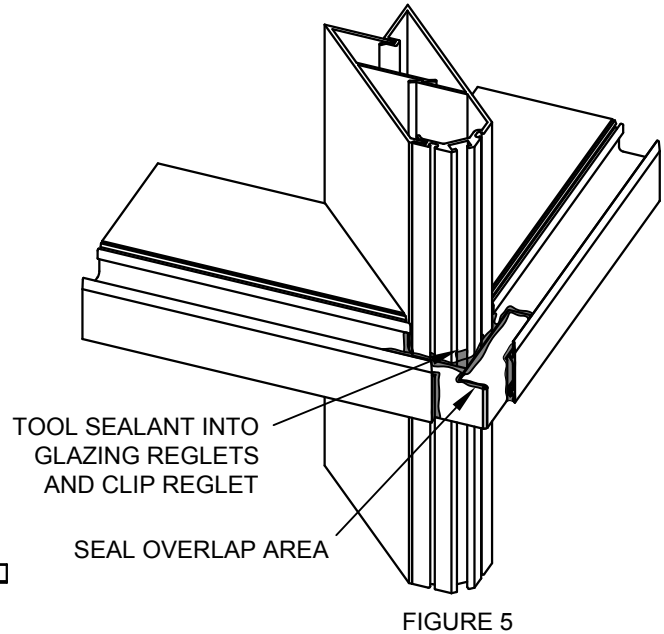

FIGURE 5

ADJUSTABLE WATER DEFLECTOR FOR 451/451T SSG DART CORNER WITHOUT COVERS

STEP A: Bend along dividing line on front face of water deflector to the required angle. One top side will have to be bent down slightly to let the other side fold over it. (Figure 2 and 3)

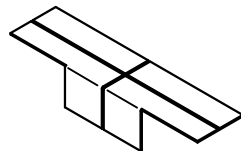

FIGURE 1

STEP B: Trial fit the modified water deflector and adjust if required.

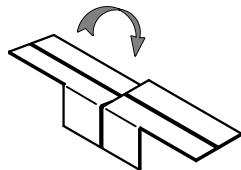

FIGURE 2

STEP C: Apply sealant around the top and down the sides of the water deflector and overlap area. Also apply sealant in the glazing reglets and clip reglets. Tool sealant. (Figure 4)

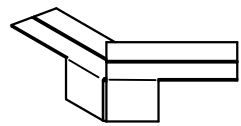

FIGURE 3

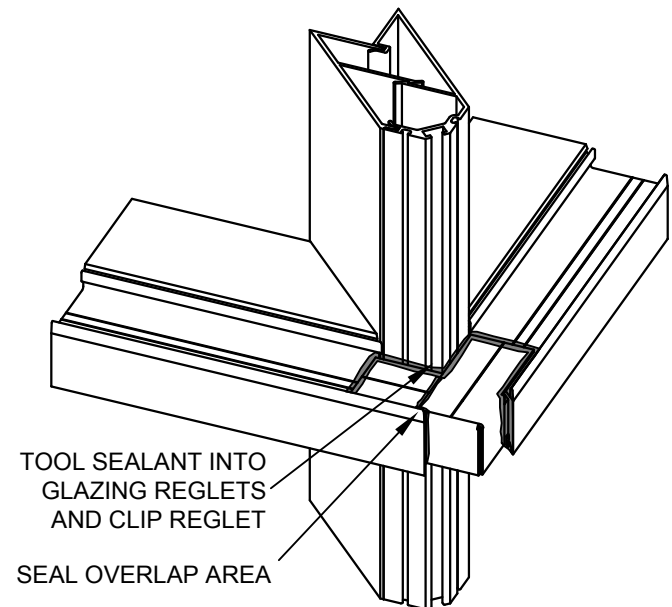
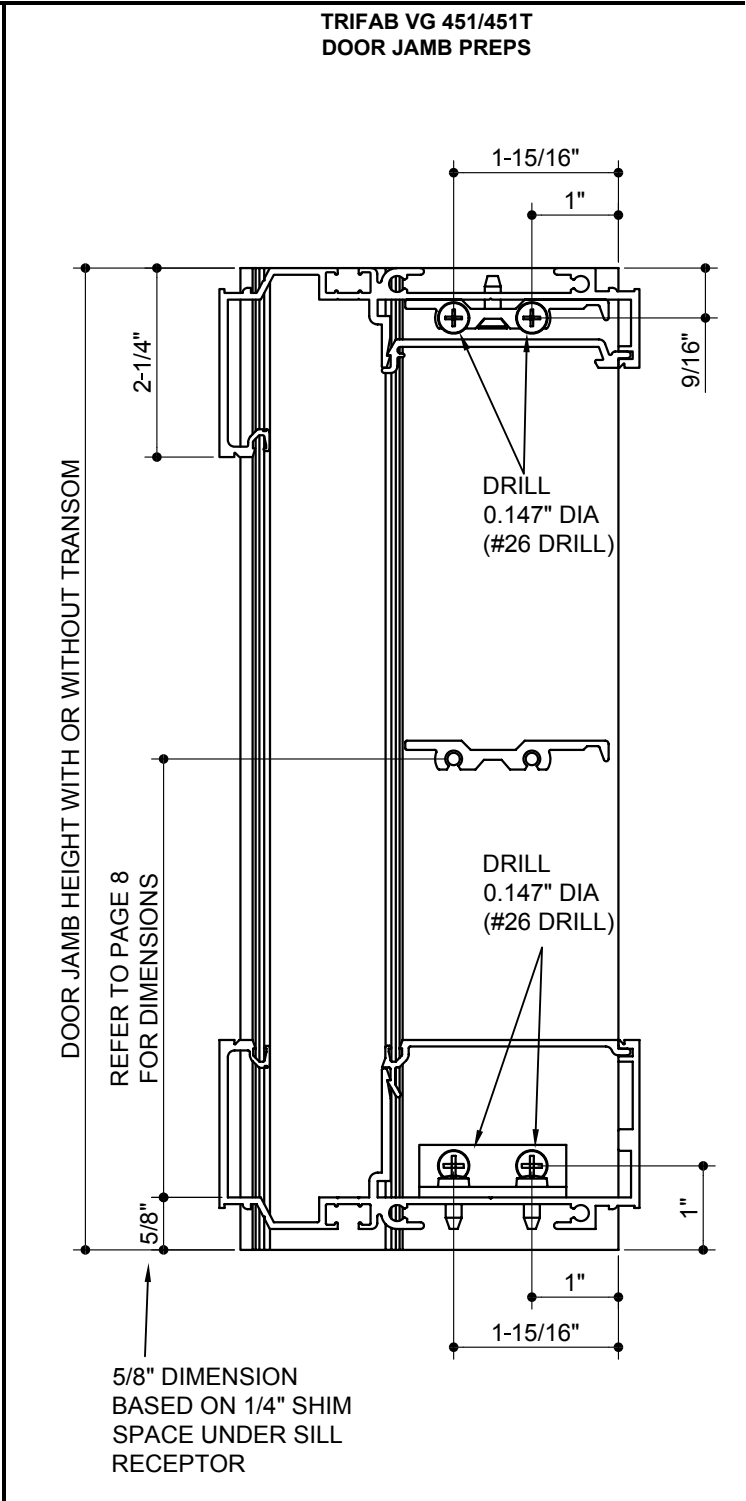
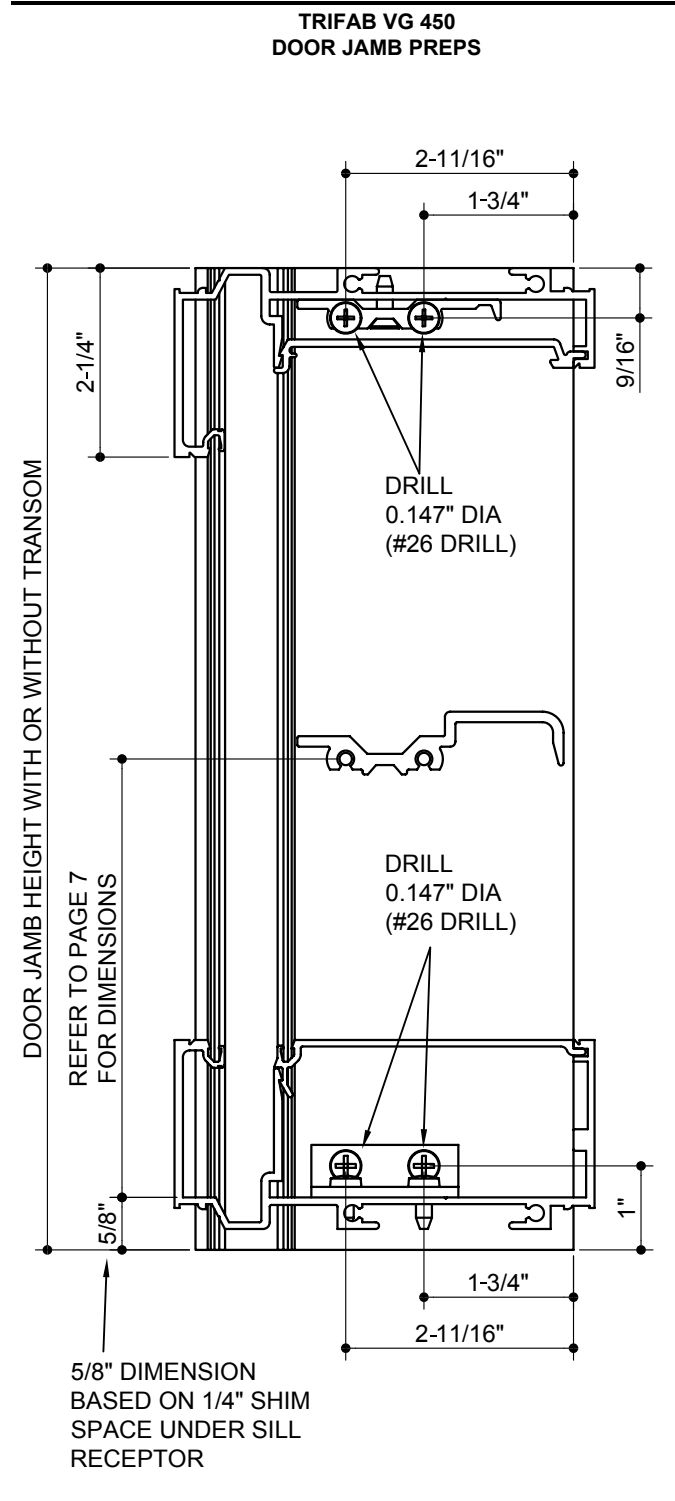

FIGURE 4

Laws and building and safety codes governing the design and use of glazed entrance, window, and curtain wall products vary widely. Kawneer does not control the selection of product configurations, operating hardware, or glazing materials, and assumes no responsibility therefor.

Kawneer reserves the right to change configuration without prior notice when deemed necessary for product improvement.
© Kawneer Company, Inc. 2009

- STEP A:** Door jambs run through to perimeter at sill. Head and Sill receptors are always interrupted at door jambs. Locate sill receptor to accommodate sill receptor and shim space at sill.
- STEP B:** Refer to pages 7 and 8 for horizontal fabrication.
- STEP D:** Drill holes for head and sill anchor clips are the locations shown below.
- STEP E:** Attach anchor clips and shear blocks to the door jamb with supplied fasteners.



Laws and building and safety codes governing the design and use of glazed entrance, window, and curtain wall products vary widely. Kawneer does not control the selection of product configurations, operating hardware, or glazing materials, and assumes no responsibility therefor.

Kawneer reserves the right to change configuration without prior notice when deemed necessary for product improvement.
© Kawneer Company, Inc. 2009

NOTE: 451 \ 451T SHOWN,
450 SIMILAR

- STEP A:** Install clip anchors onto door jamb at the specified locations. Refer to page 27.
- STEP B:** Apply sealant to the ends of the head and sill receptors. Place door jamb into position and anchor to receptors.
- STEP C:** Install horizontals as outlined on pages 23.
- STEP D:** Apply sealant to the bottom glazing pocket of the door jamb and the receptor as shown. (Figure 1)
- STEP E:** Apply sealant to the top glazing pocket of the door jamb and the receptor as shown. (Figure 2)
- STEP F:** Complete typical frame installation and glazing as outlined on pages 29 - 33.

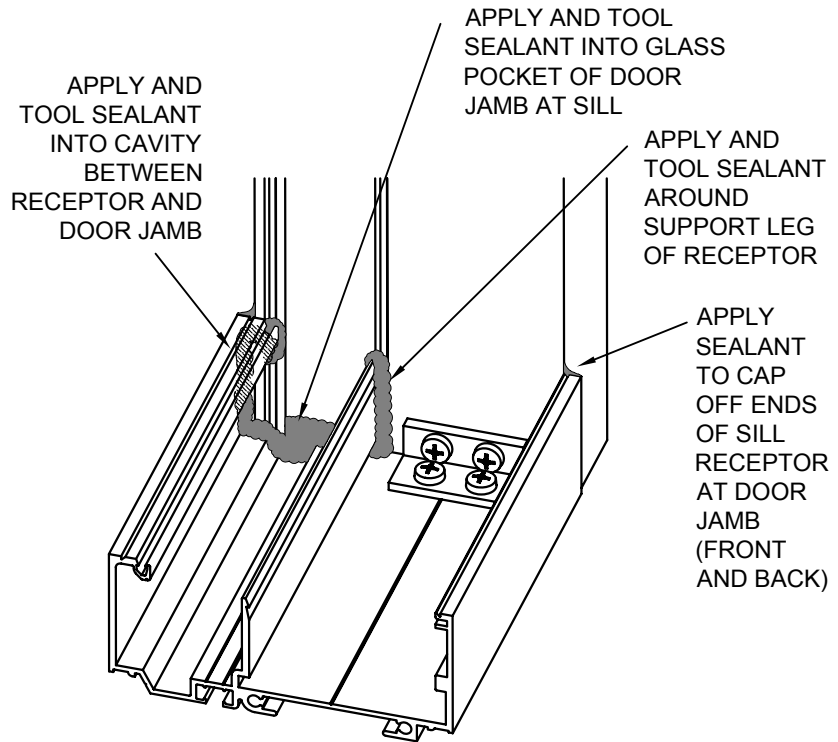

FIGURE 1

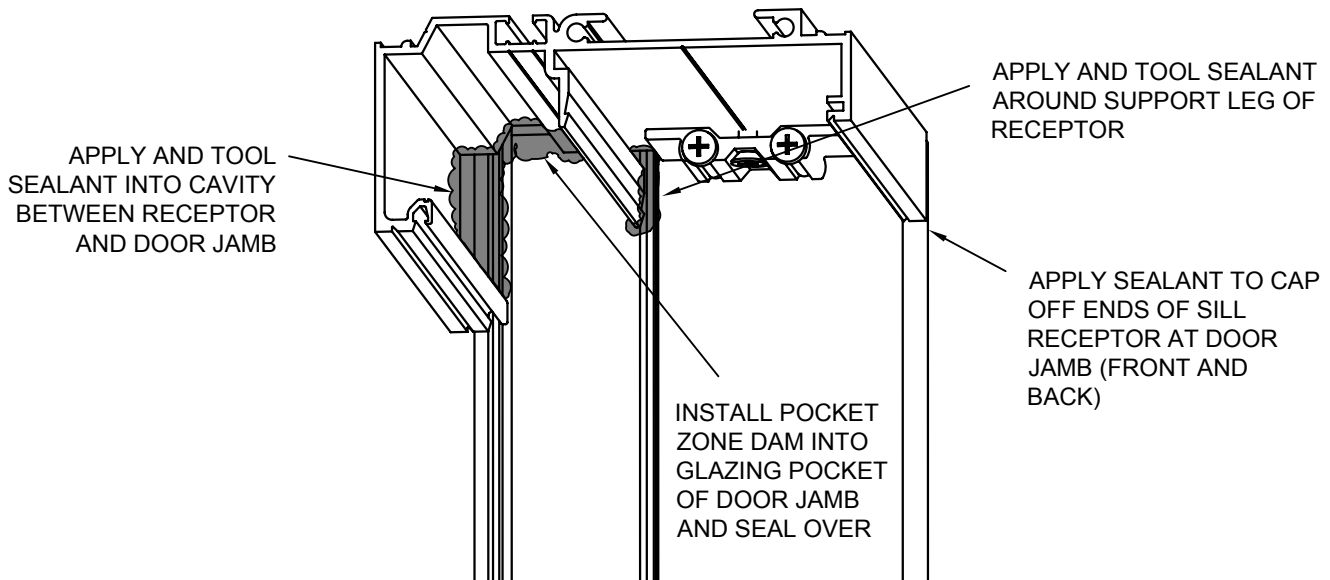

FIGURE 2

Laws and building and safety codes governing the design and use of glazed entrance, window, and curtain wall products vary widely. Kawneer does not control the selection of product configurations, operating hardware, or glazing materials, and assumes no responsibility therefor.

Kawneer reserves the right to change configuration without prior notice when deemed necessary for product improvement.
© Kawneer Company, Inc. 2009

TYPICAL INSTALLATION OF PARTIAL OR FULL LENGTH VERTICAL GLAZING ADAPTORS - PRIOR TO FRAME ASSEMBLY

Vertical glazing adaptors may be installed for partial, (Figure 1) or full-length, (Figure 2) applications at the time the frames are assembled.

- STEP A:** Cut VERTICAL glazing adaptors to D.L.O. Plus 1/2" for partial length applications or to vertical member length for full-length applications.
- STEP B:** Cut HORIZONTAL glazing adaptors to D.L.O.
- STEP C:** Snap vertical adaptors into glazing reglets of frame and assemble frame as instructed. In partial length applications, vertical adaptor should be positioned to allow sealing of the horizontal adaptor to the vertical adaptor. (approximately 1/4" projection into horizontal pocket) It may be necessary to lightly crimp vertical adaptor in place to prevent sliding.

FIGURE 1
(1/4" over 1")

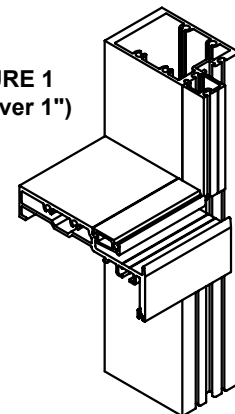
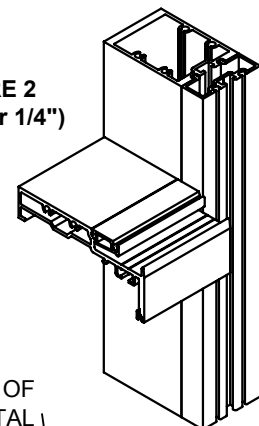

FIGURE 2
(1/4" over 1/4")



SPECIAL NOTE:

When using pre-installed vertical glazing adaptors, care should be taken at the time of the frame assembly, to seal the vertical glazing reglets where they meet the intermediate horizontals. The 1/4" water deflector should also be used on all full-length applications (Figure 4), and installed as shown in page 24. 1" water deflectors are used for partial adaptor applications as long as the adaptor does not impede water evacuation of the intermediate horizontal. The water deflector must allow water to drain into the vertical pocket beyond the edge of the glass below.

- STEP D:** Apply sealant to vertical adaptor at the final position of the snapped-in horizontal adaptor.
- STEP E:** Snap the HORIZONTAL glazing adaptors into the glazing reglet allowing the adaptor to rotate into the pocket and contact the sealant at the vertical adaptor.

SEAL ENDS OF HORIZONTAL ADAPTORS

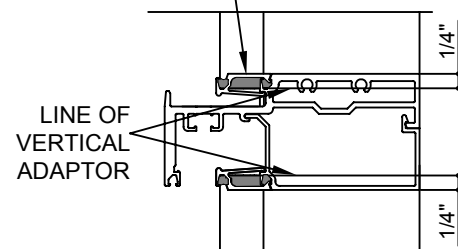

INSTALLATION OF GLAZING ADAPTORS - AFTER FRAME ASSEMBLY AND FOR FIELD RETROFIT APPLICATIONS

- STEP A:** Cut VERTICAL glazing adaptors to D.L.O. + 1/2".
- STEP B:** Make a 1/4" by 1/4" notch at each end of the vertical glazing adaptor. Notch should be made on the face side of the adaptor nearest the gasket reglet as shown. (Figure 5)
- STEP C:** Cut HORIZONTAL glazing adaptors to D.L.O.
- STEP D:** Snap vertical adaptors into glazing reglets of frame. Adaptor should be positioned to allow sealing of horizontal adaptor to the vertical adaptor. (approximately 1/4" projection into horizontal pocket) (Figure 3)

SPECIAL CARE NOTE:

Care should be taken to insure that the glazing adaptor does not impede water evacuation at the intermediate horizontal. The previously installed 1" water deflector must allow water to drain into the vertical pocket the edge of the glass below.

- STEP E:** Apply sealant to vertical adaptor at the final position of the snapped-in horizontal adaptor.
- STEP F:** Snap the HORIZONTAL glazing adaptors in the glazing reglet allowing the adaptor to rotate into the pocket and contact the sealant at the vertical adaptor.

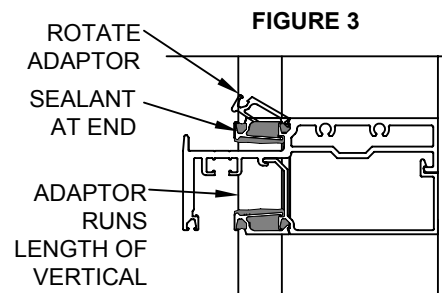

FIGURE 3

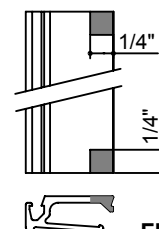

FIGURE 4

FIGURE 5

Laws and building and safety codes governing the design and use of glazed entrance, window, and curtain wall products vary widely. Kawneer does not control the selection of product configurations, operating hardware, or glazing materials, and assumes no responsibility therefor.

Kawneer reserves the right to change configuration without prior notice when deemed necessary for product improvement.
© Kawneer Company, Inc. 2009

TYPICAL INSTALLATION OF PARTIAL OR FULL LENGTH VERTICAL GLAZING ADAPTORS - PRIOR TO FRAME ASSEMBLY

- STEP A:** Cut VERTICAL glazing adaptors to D.L.O. Plus 1/2" for partial length applications or to Vertical member length minus 2-15/16" for full-length applications. Cut HORIZONTAL glazing adaptors to D.L.O.
- STEP B:** Drill attachment clearance holes in the vertical adaptor 6" from each end and every 12" on center with a #16 (0.177 dia) drill bit and countersink. Locate adaptor on mullion and match drill with #26 (0.147 dia) drill bit. Fasten adaptor to mullion using 028-727 (#8 x 1-1/4" FHTF). In partial length applications, vertical adaptor should be positioned to allow sealing of the horizontal adaptor to the vertical adaptor. (Approximately 1/4" projection into horizontal pocket)
- STEP C:** Apply sealant to vertical adaptor at the final position of the snapped-in horizontal adaptor.
- STEP D:** Snap the HORIZONTAL glazing adaptors into the glazing reglet allowing the adaptor to rotate into the pocket and contact the sealant at the vertical adaptor.

NOTE:
WHEN USING PRE-INSTALLED VERTICAL GLAZING ADAPTORS, CARE SHOULD BE TAKEN, AT THE TIME OF THE FRAME ASSEMBLY, TO SEAL THE VERTICAL GLAZING REGLETS WHERE THEY MEET THE INTERMEDIATE HORIZONTALS. THE 1/4" WATER DEFLECTOR SHOULD ALSO BE USED ON ALL FULL-LENGTH APPLICATIONS AND INSTALLED AS SHOWN ON PAGE 24. 1" WATER DEFLECTORS ARE USED FOR PARTIAL ADAPTOR APPLICATIONS AS LONG AS THE ADAPTOR DOES NOT IMPEDE WATER EVACUATION OF THE INTERMEDIATE HORIZONTAL.

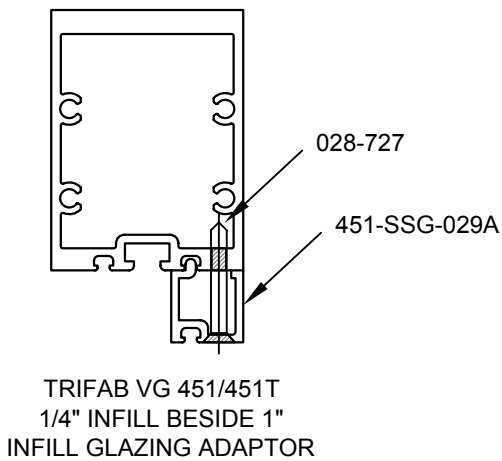

FIGURE 1

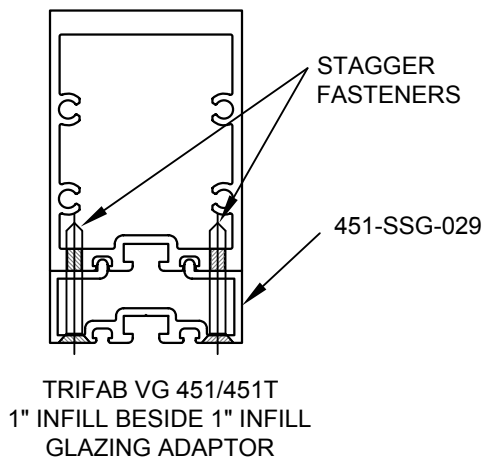
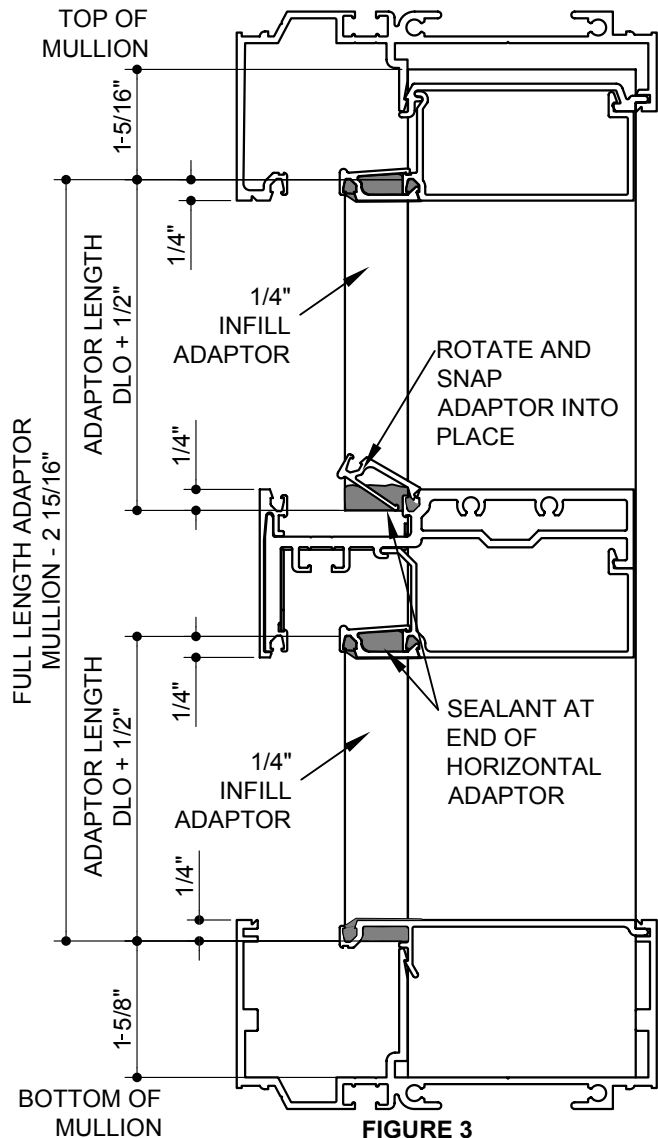

FIGURE 2



Laws and building and safety codes governing the design and use of glazed entrance, window, and curtain wall products vary widely. Kawneer does not control the selection of product configurations, operating hardware, or glazing materials, and assumes no responsibility therefor.

Kawneer reserves the right to change configuration without prior notice when deemed necessary for product improvement.
 © Kawneer Company, Inc. 2009

SSG AND WEATHERSEAL SYSTEMS WILL ACCEPT 1/4" OR 1" VISION AND 1/4" OR 1" SPANDREL INFILLS.

NOTES:

- 1) THESE FORMULAS DO NOT ALLOW FOR UNDERSIZE OR OUT OF SQUARE DAYLITE OPENINGS.
- 2) THE GLASS MANUFACTURER MUST INDICATE THE SPECIFIC GLAZING REQUIREMENTS FOR THE MATERIAL BEING USED.

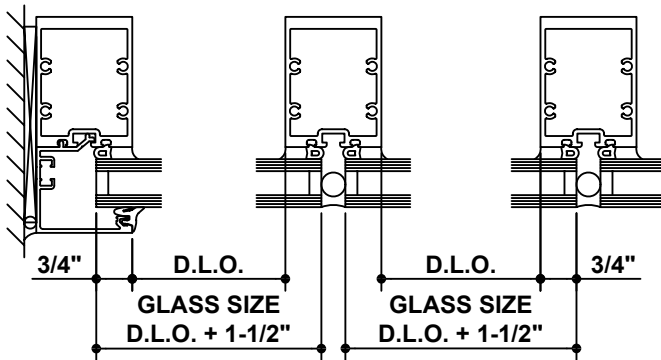

SSG / WEATHERSEAL TRIFAB VG 451/451T

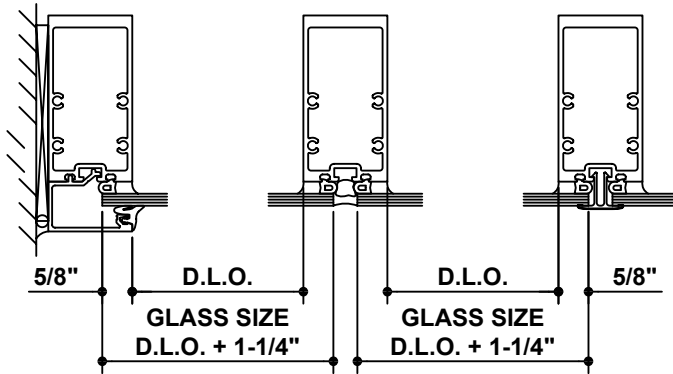

SSG / WEATHERSEAL TRIFAB VG 450

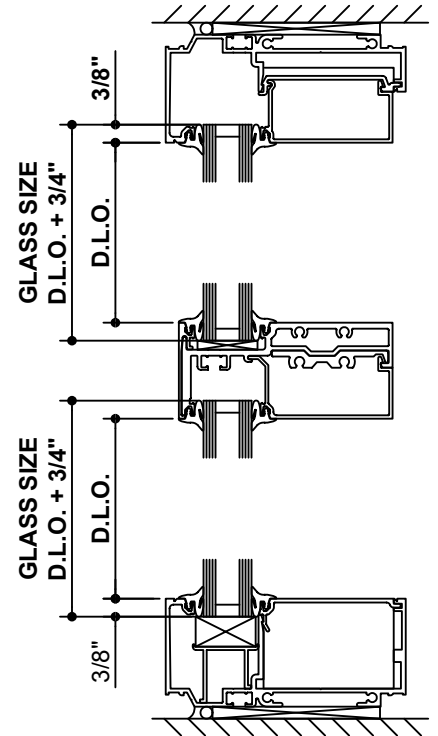

SSG / WEATHERSEAL ALL SYSTEMS

SSG / WEATHERSEAL GLAZING CHART

INFILL THICKNESS	VERTICAL & JAMB ADAPTOR	HEAD & SILL ADAPTOR	VERTICAL SPACER	HEAD, JAMB & SILL GASKET	EXTERIOR HEAD & SILL TWO-COLOR GASKET	WEATHERSEAL
1/4"	—	—	127-008	027-074	027-074C	450-SSG-250
1/4" Adapted	451-SSG-029 or 451-SSG-029A	451-VG-029 @ HEAD 451-SSG-027 INSERT @ SILL	127-008	027-074	027-074C	450-SSG-250
1"	—	—	127-008	027-074	027-074C	451-SSG-250

TYPICAL WEATHERING

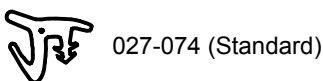

EXTERIOR HEAD & SILL WEATHERINGS FOR TWO-COLOR SYSTEM

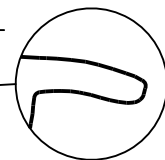
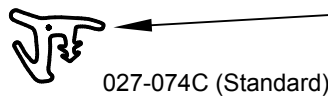

Two Color Gaskets have a Extended Lip.

- STEP A:** Cut horizontal and vertical gaskets, and SSG spacer to approximate length of D.L.O. + 1/4 per foot of D.L.O..
- STEP B:** Install setting blocks and/or setting block chairs into the horizontal members. **CHECK DEADLOAD CHARTS IN ARCHITECTURAL DETAIL MANUAL FOR PROPER SETTING BLOCK SPACING.**
- STEP C:** At all intermediate horizontal water deflectors, cut the dart and back leg off of exterior weathering, (Figure 1). This will create a weep slot after the horizontal cover is installed.
- STEP D:** Install exterior horizontal covers. Covers should not exceed a maximum of 10 feet. if an elevation is longer than 10 feet, splice the horizontal covers at mullions as shown (Figure 2).
- STEP E:** Install gasket on the side opposite glass stop first. Insert gaskets into horizontal members first starting at the ends and working towards the center. Install vertical gaskets in the same manner.
- STEP F:** Install glass in the frame opening (Figure 3). Install temporary glass retainers to hold glass in place. Retainers should be spaced a maximum of 30" on center. If high windload conditions are anticipated, additional retainers may be needed. Consult your sealant and glass supplier for spacing recommendations.

NOTE:
EXTERIOR HORIZONTAL GASKETS RUN CONTINUOUS ACROSS OPENING. CUT THIS GASKET TO APPROXIMATE LENGTH OF OPENING WIDTH + 1/4" PER FOOT OF OPENING.

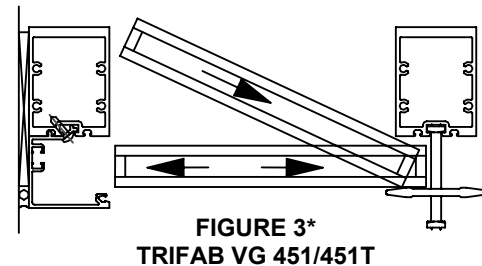
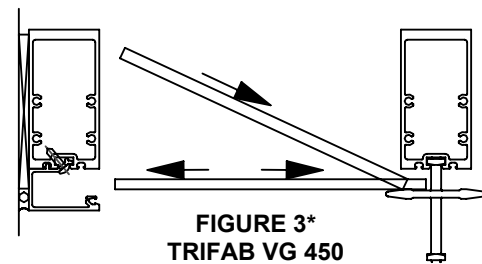
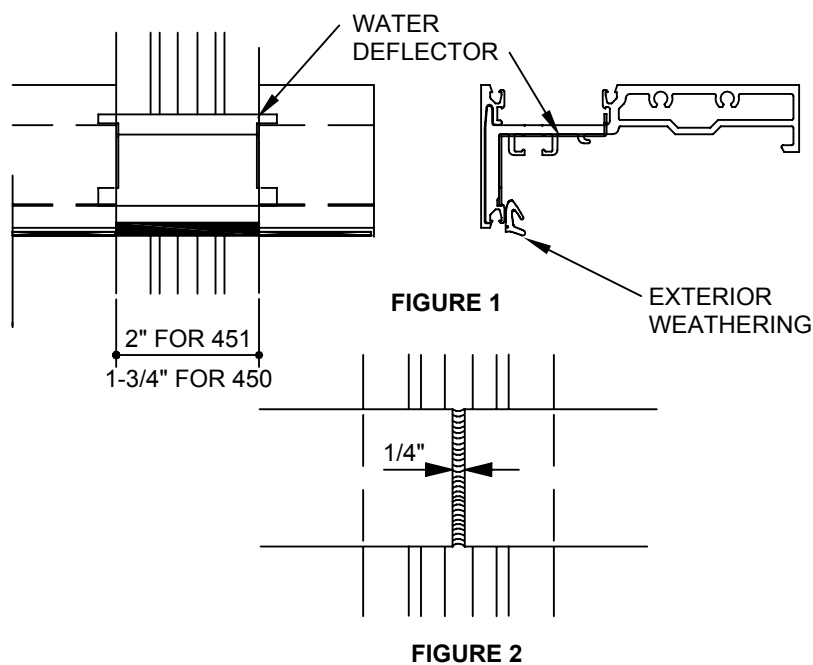

***NOTE:**
LAST BAY GLASS INSERTION REVERSED.

- STEP G:** Install adjacent glass light and then install SSG glazing spacer along mullion at each light.
- STEP H:** Apply sealant along verticals where glass stop meets, then install glass stops (Figure 4).
- STEP I:** Install interior push-on gasket.
- STEP J:** Mask SSG mullion and glass as required. Install the interior, vertical structural seal.
- STEP K:** Apply exterior seal at the butt glass joint.

NOTE:
KAWNEER DOES NOT SUPPLY THE STRUCTURAL SILICONE SEALANT. THIS SEALANT IS TO BE RECOMMENDED BY THE SEALANT MANUFACTURER. REFERENCE THE SSG GLAZING NOTE FOUND IN THE GENERAL NOTES SECTION OF THIS MANUAL.

APPLY BEAD OF SEALANT ALONG VERTICAL REGLETS WHERE GLASS STOP MEETS VERTICAL.

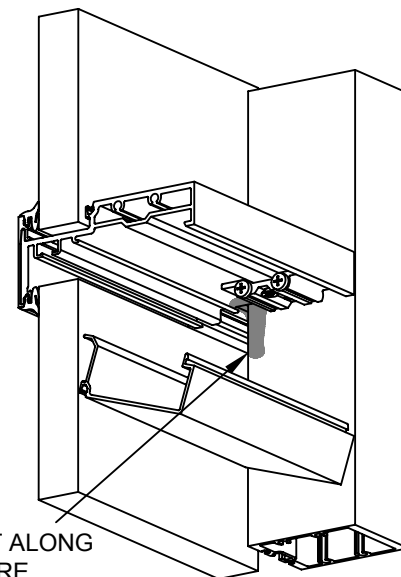

- STEP A:** Cut horizontal and vertical gaskets, and SSG spacer to approximate length of D.L.O. + 1/4" per foot of D.L.O.
- STEP B:** Install setting blocks and/or setting block chairs into the horizontal members. **CHECK DEADLOAD CHARTS IN ARCHITECTURAL DETAIL MANUAL FOR PROPER SETTING BLOCK SPACING.**
- STEP C:** At all intermediate horizontal water deflectors, cut the dart and back leg off of exterior weathering, (Figure 1). This will create a weep slot after the horizontal cover is installed.
- STEP D:** Install exterior horizontal covers. Covers should not exceed a maximum of 10 feet. If an elevation is longer than 10 feet, splice the horizontal covers at mullions as shown (Figure 2).
- STEP E:** Install gasket on the side opposite glass stop first. Insert gaskets into horizontal members first starting at the ends and working towards the center. Install vertical gaskets in the same manner.
- STEP F:** Install glass in the frame opening (Figure 3). Install snap-in Weatherseal to hold glass in place.

NOTE:
EXTERIOR HORIZONTAL GASKETS RUN CONTINUOUS ACROSS OPENING. CUT THIS GASKET TO APPROXIMATE LENGTH OF OPENING WIDTH + 1/4" PER FOOT OF OPENING.

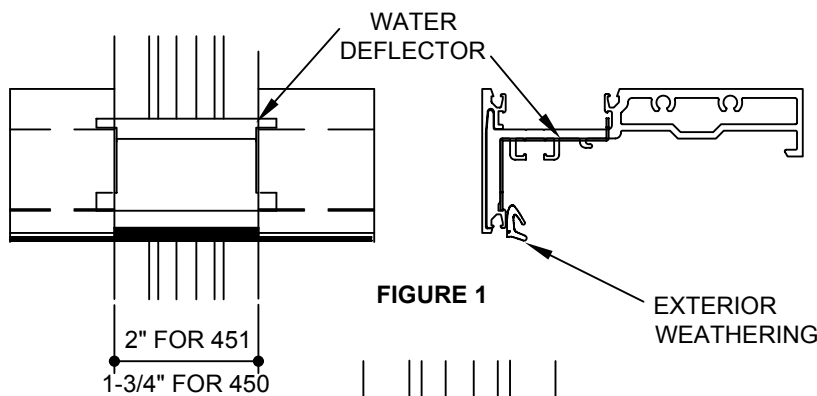

FIGURE 1

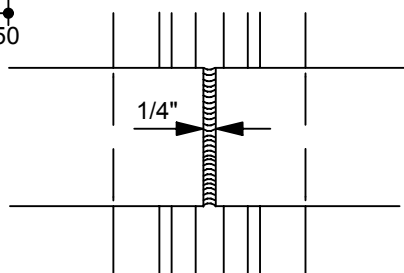

FIGURE 2

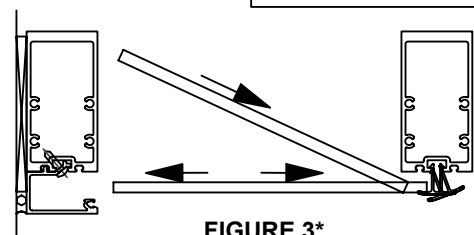

FIGURE 3*
 TRIFAB VG 450

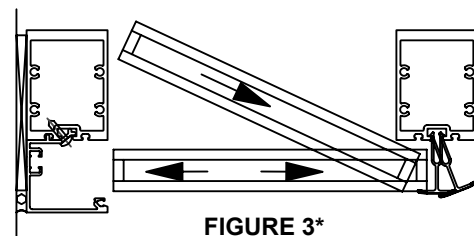
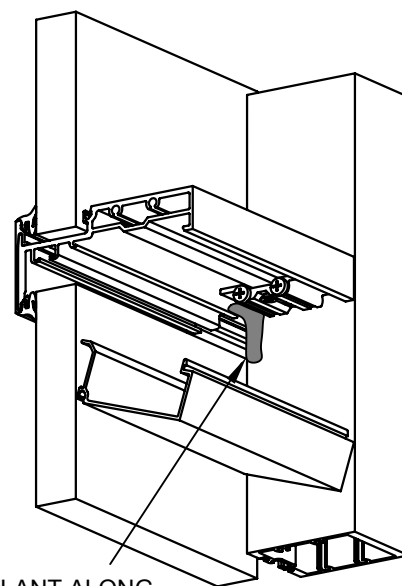

FIGURE 3*
 TRIFAB VG 451/451T

***NOTE:**
LAST BAY GLASS INSERTION REVERSED

- STEP G:** Install adjacent glass light and then install SSG glazing spacer along mullion at each light.
- STEP H:** Apply sealant along verticals where glass stop meets, then install glass stops (Figure 4).
- STEP I:** Install interior push-on gasket.
- STEP J:** Mask SSG mullion and glass as required. Install the interior, vertical structural seal.

NOTE:
KAWNEER DOES NOT SUPPLY THE STRUCTURAL SILICONE SEALANT. THIS SEALANT IS TO BE RECOMMENDED BY THE SEALANT MANUFACTURER. REFERENCE THE SSG GLAZING NOTE FOUND IN THE GENERAL NOTES SECTION OF THIS MANUAL.



APPLY BEAD OF SEALANT ALONG VERTICAL REGLETS WHERE GLASS STOP MEETS VERTICAL

FIGURE 4

Laws and building and safety codes governing the design and use of glazed entrance, window, and curtain wall products vary widely. Kawneer does not control the selection of product configurations, operating hardware, or glazing materials, and assumes no responsibility therefor.

Kawneer reserves the right to change configuration without prior notice when deemed necessary for product improvement.

© Kawneer Company, Inc. 2009

Laws and building and safety codes governing the design and use of glazed entrance, window, and curtain wall products vary widely. Kawneer does not control the selection of product configurations, operating hardware, or glazing materials, and assumes no responsibility therefor.

Kawneer reserves the right to change configuration without prior notice when deemed necessary for product improvement.

© Kawneer Company, Inc. 2009

Laws and building and safety codes governing the design and use of glazed entrance, window, and curtain wall products vary widely. Kawneer does not control the selection of product configurations, operating hardware, or glazing materials, and assumes no responsibility therefor.

Kawneer reserves the right to change configuration without prior notice when deemed necessary for product improvement.

© Kawneer Company, Inc. 2009



**KAWNEER COMPANY, INC
TECHNOLOGY PARK/ATLANTA
555 GUTHERIDGE COURT
NORCROSS, GEORGIA 30092**