

HANDLING, STORING, AND PROTECTION OF ALUMINUM

The material must be protected against damage. The following precautions are recommended to assure early acceptance of your products and workmanship.

A. HANDLE CAREFULLY - Don't drop from the truck. Stack with adequate separation so material will not rub together. Store off the ground. Protect against elements and other construction trades. Wear hand protection to prevent injury due to sharp edges of cut extrusions.

B. KEEP MATERIAL AWAY FROM WATER, MUD AND SPRAY - Prevent cement, plaster, or other materials from damaging the finish.

C. PROTECT THE MATERIALS AFTER ERECTION - Protect by wrapping with Kraft paper or by erecting Visqueen or canvas splatter screen. Cement, plaster, terrazzo, other alkaline solutions and acid based materials used to clean masonry are very harmful to the finish and should be removed with water and mild soap IMMEDIATELY.

GENERAL INSTALLATION NOTES

The following practices are recommended for all installations:

A. CHECK SHOP DRAWINGS, INSTALLATION INSTRUCTIONS and GLAZING INSTRUCTIONS to become thoroughly familiar with the project. The SHOP DRAWINGS take precedence and include specific details for the project. The INSTALLATION INSTRUCTIONS are of a general nature and cover most common conditions.

B. All materials are to be INSTALLED PLUMB, LEVEL, AND TRUE.

C. All work should start from bench marks and/or column lines as established by the ARCHITECTURAL DRAWINGS and the GENERAL CONTRACTOR. Check mullion spacing from both ends of the masonry opening to prevent dimensional buildup of day light opening.

D. Make certain that construction which will receive your materials is in accordance with the contract documents. If not, notify the GENERAL CONTRACTOR IN WRITING and resolve differences before proceeding with your work.

E. Isolate all aluminum to be placed directly in contact with uncured masonry or incompatible materials with a heavy coat of zinc chromate or bituminous paint.

F. Check all materials on arrival for quantity and be sure you have everything required to begin installation.

G. Sealants must be compatible with all materials with which they have contact, including other sealant surfaces. Consult with sealant manufacturer for recommendations relative to joint size, shelf life, compatibility, priming, tooling, adhesion, etc.

H. FASTENING - "Fastening" means any method of securing one part to another or to adjacent materials. These instructions specify only those fasteners used within the system. Due to varying perimeter conditions and job performance requirements, anchor fasteners are not specified in these instructions. For anchor fastening, refer to the Shop Drawings or consult the fastener supplier.

I. CHECK OPENINGS - Make certain that the opening which will receive your materials is in accordance with the contract documents. If not, notify the GENERAL CONTRACTOR IN WRITING and resolve differences before proceeding with your work.

J. BUILDING CODES - Glass and glazing codes governing the design and use of products vary widely. Kawneer does not control the selection of product configurations, operating hardware, or glazing materials, and assumes no responsibility for these design considerations. It is the responsibility of the owner, specifier, architect, general contractor and the installer to make these selections in strict conformance with all applicable codes.

K. EXPANSION JOINTS - Expansion joints and perimeter seals shown in these instructions and in the shop drawings are shown at normal size. Actual dimensions may vary due to perimeter conditions and /or difference in metal temperature between the time of fabrication and time of installation. For example, a 12 foot unrestrained length of aluminum extrusion can expand or contract 3/32" over a 50° F temperature change. Any movement potential should be accounted for at the time of installation.

L. FIELD TESTING - It is recommended that a Water Hose Test be conducted once a sufficient portion of the framing is installed, glazed and caulked to ensure proper installation. The Water Hose Test shall be conducted in accordance with AAMA 501.2. In addition, larger projects should have periodic Water Hose Tests as additional precautionary measures.

CLEARWALL SBI SILICONE AND CLEARWALL SBIT TAPE GLAZING NOTE

The Clearwall SBI system requires a interface to be applied with structural silicone. The Clearwall SBIT system requires a interface to be applied with 3M VHB SSG tape (B23F). The structural silicone or SSG tape should be applied in a controlled environment to preserve the condition of the structural silicone or tape contact surfaces once they've been cleaned and prepared per sealant manufacturer's or 3M's (tape) recommendations.

For the Clearwall SBI system, the glazing installer is responsible for selecting and contacting the silicone manufacturer to determine which type of silicone is to be used and what samples are required to be submitted for adhesion and compatibility testing. For the Clearwall SBIT system, the glazing installer is responsible for contacting 3M, the tape manufacturer, to determine what samples are required to be submitted for adhesion and compatibility testing. The silicone sealant nor tape shall be applied to Kawneer products without the approval of the silicone manufacturer or 3M (tape) and until all required testing is completed and detailed application instructions have been delivered to the installer. If you find that silicone manufacturer's or 3M tape installation instructions are not in accordance with Kawneer's installation instructions, it is your responsibility to notify Kawneer of the conflict **prior to glazing**.

Your glass supplier must be made aware that their glass will be used in an SSG or SSG tape application. The application must be approved by the glass supplier **prior to glazing**.

For any structural silicone glazed or SSG tape product applications that is not shown in Kawneer's standard literature, the application must be approved.

For Clearwall SBIT applications, 3M's VHB Structural Glazing Tape Technical Guide contains a Customer Warranty Request Form for the tape application and must be used to initiate the Initial Project Assessment and certification.

CLEARWALL NOTES

THESE SUPPLEMENTAL INSTRUCTIONS SHOW THE ITEMS THAT ARE UNIQUE TO THE CLEARWALL STICK SYSTEM ONLY. REFER TO THE STANDARD CLEARWALL SS INSTALLATION INSTRUCTIONS FOR ALL ITEMS NOT ADDRESSED HEREIN.

Clearwall is available with 1" framing members only. Clearwall requires Viracon glass with a black recessed air spacer sealed with structural silicone. Please contact Viracon for glass limitations, sightlines and coating edge deletions. Clearwall SBI or SBIT can utilize a standard structural silicone glazed infill but requires the glass to be structurally siliconed or SSG taped to an interface. Clearwall SBIT was tested using 3M VHB SSG Tape (B23F).

Glass bite is 15/16" at all verticals and horizontals. Glass sizes must be calculated from approved shop drawings.

Unless otherwise specified, it is recommended that silicone sealant be used for all internal seals.

Sealant or tape must be applied per the sealant or tape manufacturer's recommendations and pass all adhesion and compatibility testing. At all joint seals, sealant must adhere to metal and gasket materials. Clean all surfaces prior to application of sealant or tape and prime where necessary to achieve proper adhesion.

CHECK OPENINGS

Elevations and slabs must be within adjustment of anchoring system. See approved shop drawings for allowable adjustment.

Anchoring surfaces of perimeter construction must be level and plumb within the adjustment limits of the head, sill and jamb. See approved shop drawings for allowable adjustment.

LAYOUT ANCHOR AND MULLIONS CENTERLINES

Use wall lines established by the general contractor. On each floor lay out a reference line to establish in and out wall locations.

Use column center lines established by the general contractor. On each floor lay out mullion center lines and anchor center lines.

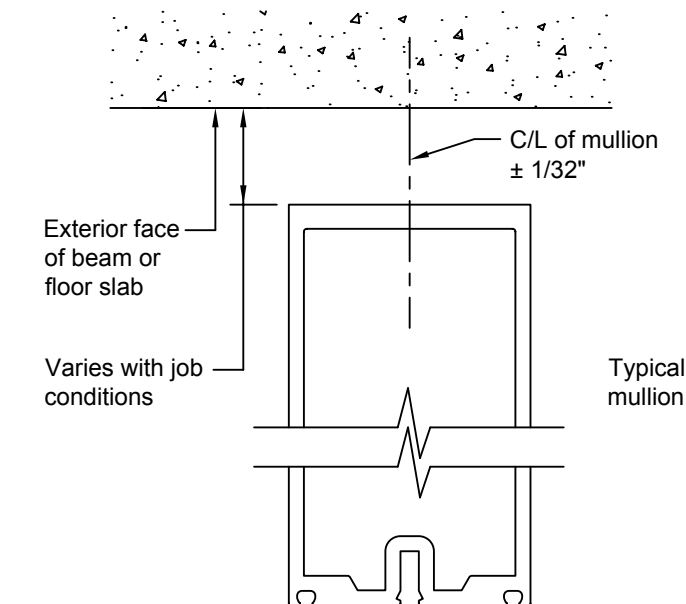

See approved shop drawings for anchor lay outs.

172971 (SHT 1 OF 3)

CONFIDENTIAL AND PROPRIETARY INFORMATION
KAWNEER COMPANY INC.

THESE DRAWINGS ARE THE SOLE AND EXCLUSIVE PROPERTY OF KAWNEER AND CONTAIN SENSITIVE, PRIVILEGED OR CONFIDENTIAL INFORMATION WHICH MAY BE USED ONLY FOR ITS BENEFIT. THE DISCLOSURE OF THESE DRAWINGS TO UNAUTHORIZED PERSONS IS STRICTLY PROHIBITED. THIS DOCUMENT AND ALL COPIES MUST BE RETURNED UPON DEMAND.
© COPYRIGHT KAWNEER COMPANY, INC., 2011

INSTALL PRESET ANCHORS IF APPLICABLE

USING LOCATION LINES PREVIOUSLY ESTABLISHED INSTALL PRESET ANCHORS IN PLACE PER APPROVED SHOP DRAWINGS.

FRAME ASSEMBLY

ATTACH ANCHORS TO MULLIONS WHERE APPLICABLE.

ANCHOR PREP MAY BE FABRICATED IN THE FIELD OR FACTORY. CONSULT APPROVED SHOP DRAWINGS FOR CORRECT METHOD.

STANDARD ANCHOR PREP IS THRU-BOLTED AT INTERMEDIATE VERTICALS AND TAPPING PLATES ARE USED AT JAMB VERTICALS. REFER TO APPROVED SHOP DRAWINGS FOR CORRECT METHOD.

WHEN WELDING ANCHORS, PROTECT INSTALLED GLASS AND METAL FROM WELD SPLATTER.

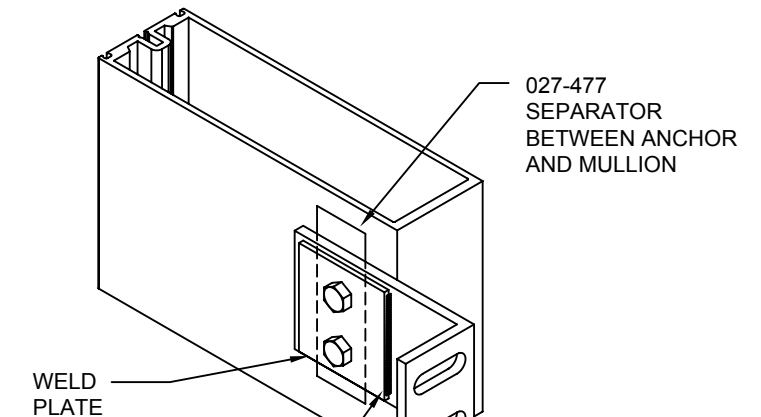

SIZE AND SPACING OF WELD PER APPROVED SHOP DRAWINGS

DO NOT OVER TIGHTEN ANCHOR CONNECTIONS. TIGHTEN TO A "SNUG TIGHT" POSITION WITH PARTS BROUGHT INTO GOOD CONTACT. BE SURE ANY SPRING TYPE LOCK WASHERS ARE COMPRESSED. THEN TIGHTEN APPROXIMATELY 1/2 MORE TURN.

KAWNEER

Product Engineering & Development

95514-04
03/11/11

CLEARWALL
SB/SBI/SBIT SUPPL.
INSTALLATION
INSTRUCTIONS

172971 (SHT 1 OF 3)

FRAME ASSEMBLY

ATTACH SHEAR BLOCKS.

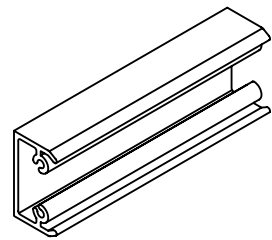

TYPICAL SHEAR BLOCKS 172-219

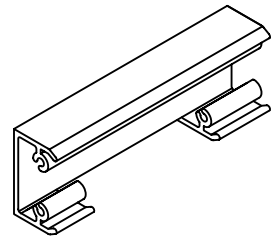

OPTIONAL HEAD AND SILL SHEAR BLOCKS 172-219 MODIFIED AS SHOWN TO CLEAR ANCHOR BOLTS IF REQUIRED

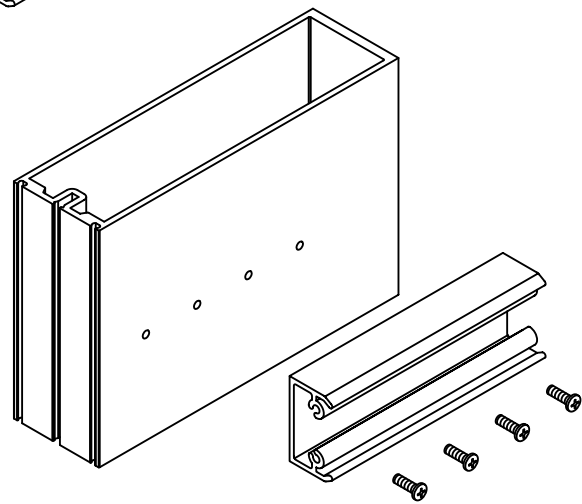

ATTACH SHEAR BLOCKS WITH FOUR (4) 128-396 SCREWS #12 x 7/16" B PAN HEAD TYPE B

INSTALL VERTICAL MULLIONS

DIMENSION BUILD-UP CHECK

CHECK OVERALL FRAME DIMENSIONS ABOUT EVERY FIVE MULLIONS ON LONG RUNS. THIS IS TO AVOID DIMENSION BUILD-UP.

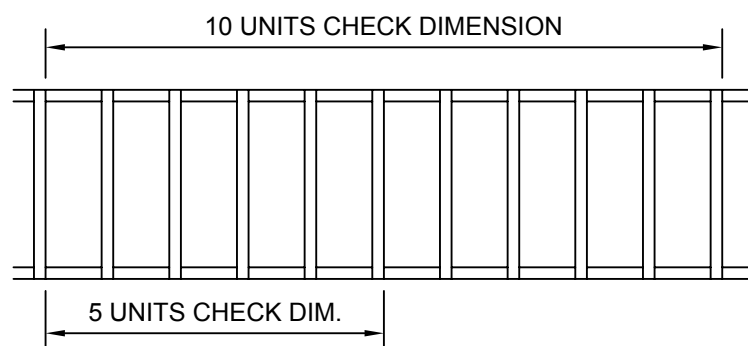

INSTALL VERTICAL MULLIONS

"F" OR "T" ANCHORS WHERE APPLICABLE

"F" AND "T" ANCHOR FASTENER LOCATIONS PER APPROVED SHOP DRAWINGS

THESE SHEAR BLOCKS MAY NEED TO BE REMOVED TO INSTALL AN ANCHOR FASTENER THAT MIGHT BE LOCATED CLOSE TO THE MULLION

"F" AND "T" ANCHOR FASTENER LOCATIONS PER APPROVED SHOP DRAWINGS

AT MULLION JAMB SIDE, APPLY (2) 128-396 SCREWS AS SHOWN TO CENTER F-CLIPS AS REQUIRED.

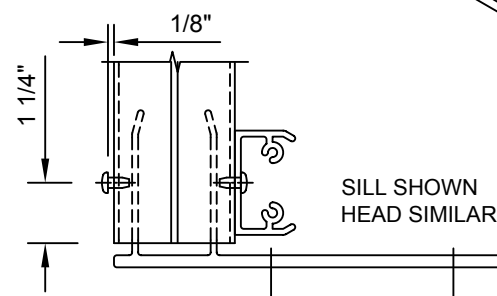

INSTALL HEAD/SILL AND INTERMEDIATE HORIZONTALS

FOR BOTH HORIZONTAL ENDS APPLY SEALANT AS SHOWN BELOW AND TOOL SEALANT AFTER ASSEMBLY.

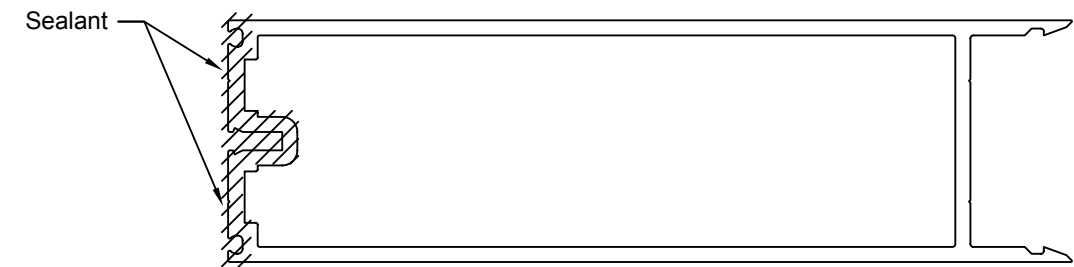

CLEARWALL SB/SBI/SBIT SUPPL. INSTALLATION INSTRUCTIONS

Product Engineering & Development

95514-06
04/20/12

172971 (SHT 2 OF 3)

INSTALL HEAD/SILL AND INTERMEDIATE HORIZONTALS

ASSEMBLE HORIZONTALS TO VERTICALS USING 128-284 #12 X 1 1/2" FHTF TYPE AB AT EXTERIOR SIDE AND 128-267 #12 X 1" PHTF TYPE AB AT INTERIOR SIDE.

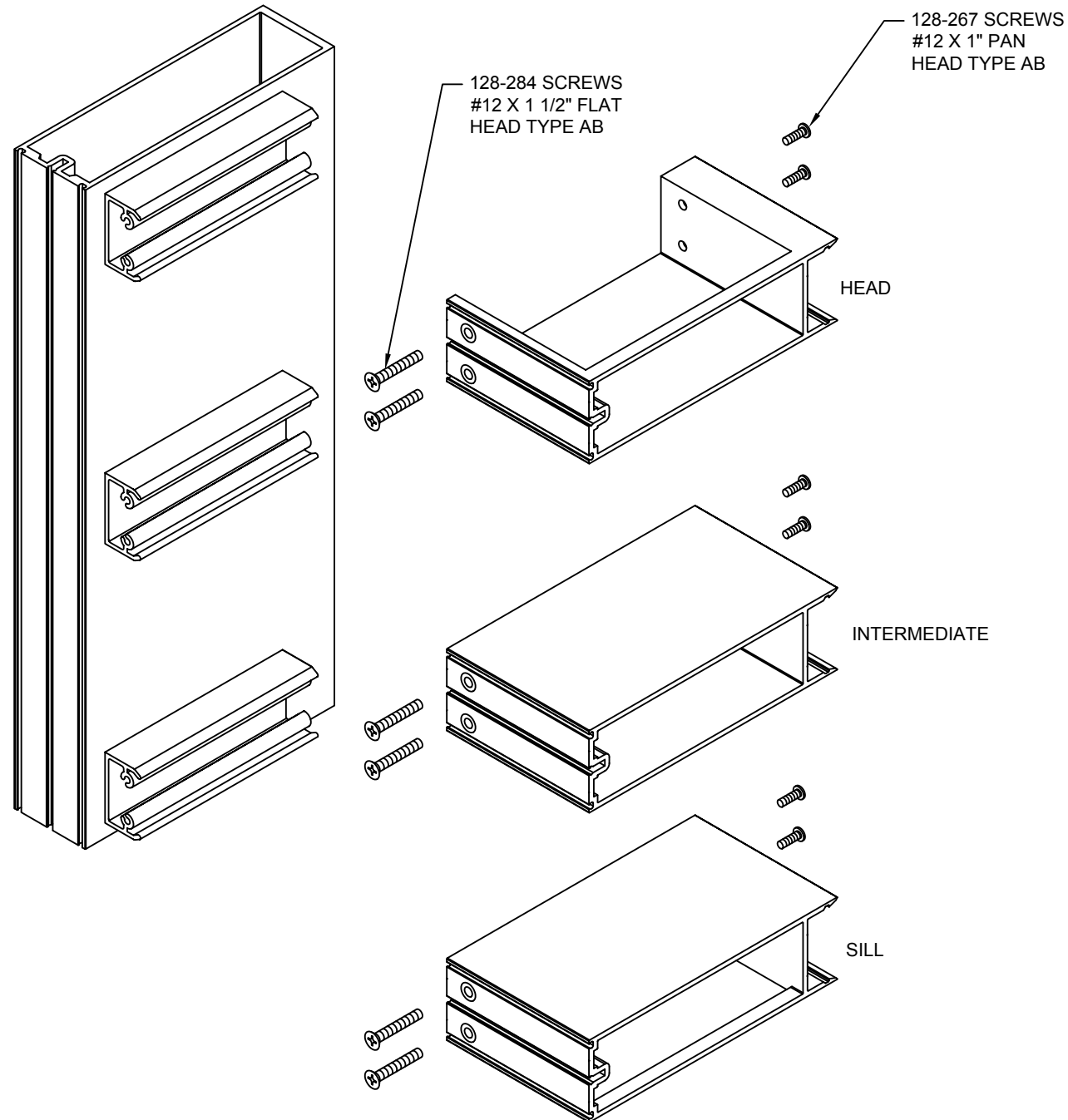

INSTALL HORIZONTALS AT LAST BAY

SLIDE THE LAST BAY HORIZONTALS IN FROM THE EXTERIOR AND ATTACH THE 162-348 CLIP OVER THE NOTCH IN THE INSIDE WEB.

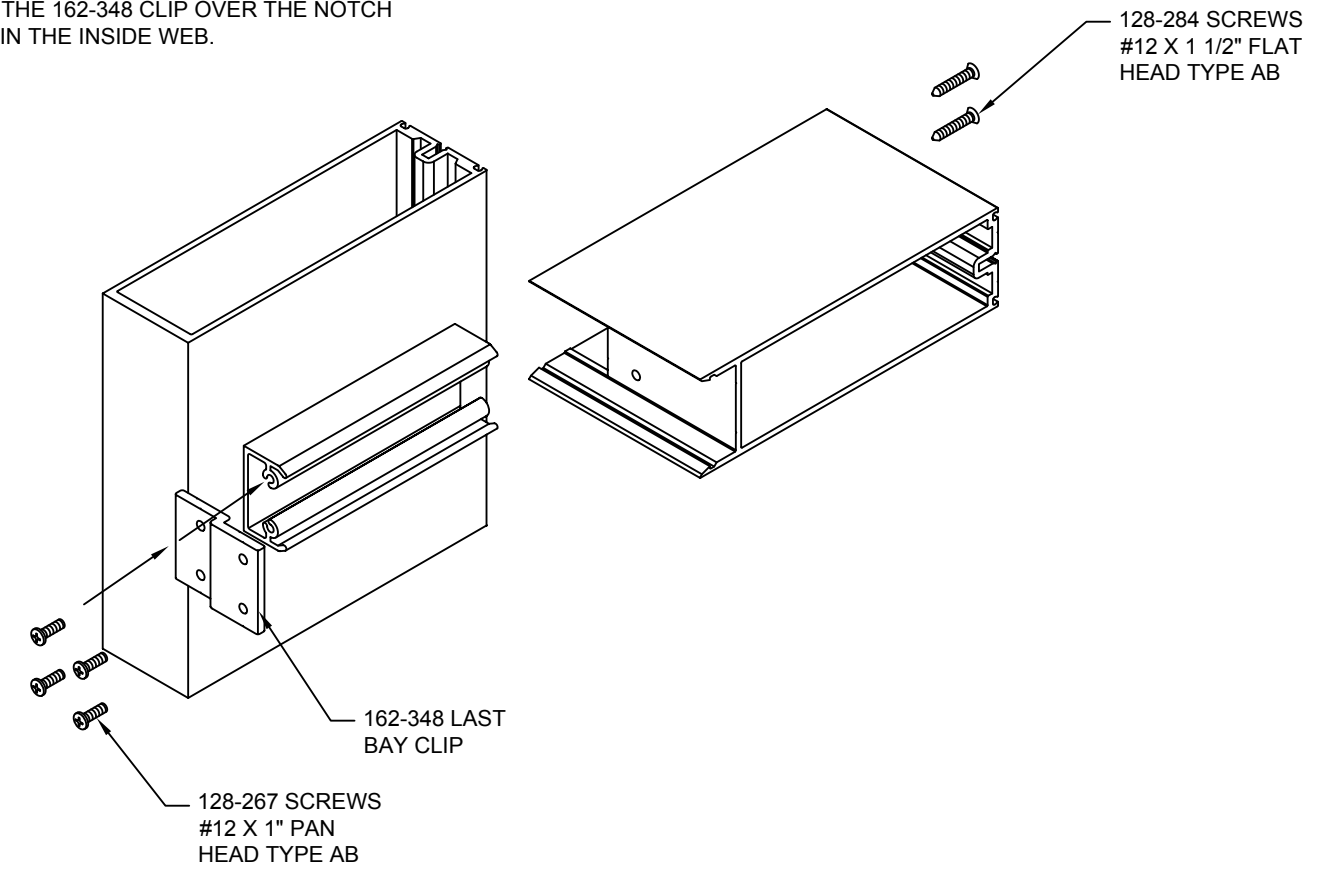

PRIOR TO INSTALLING GASKETS, MAKE SURE ALL GASKET GROOVES AND POCKETS SHOULD BE CLEAN.

SEE STANDARD INSTALLATION INSTRUCTIONS



CLEARWALL
SB/SBI/SBIT SUPPL.
INSTALLATION
INSTRUCTIONS

Product Engineering & Development

95514-06
04/20/12

172971 (SHT 3 OF 3)