

TUBELITE®

DEPENDABLE

**LEADERS IN ECO-EFFICIENT STOREFRONT,
CURTAINWALL AND ENTRANCE SYSTEMS**

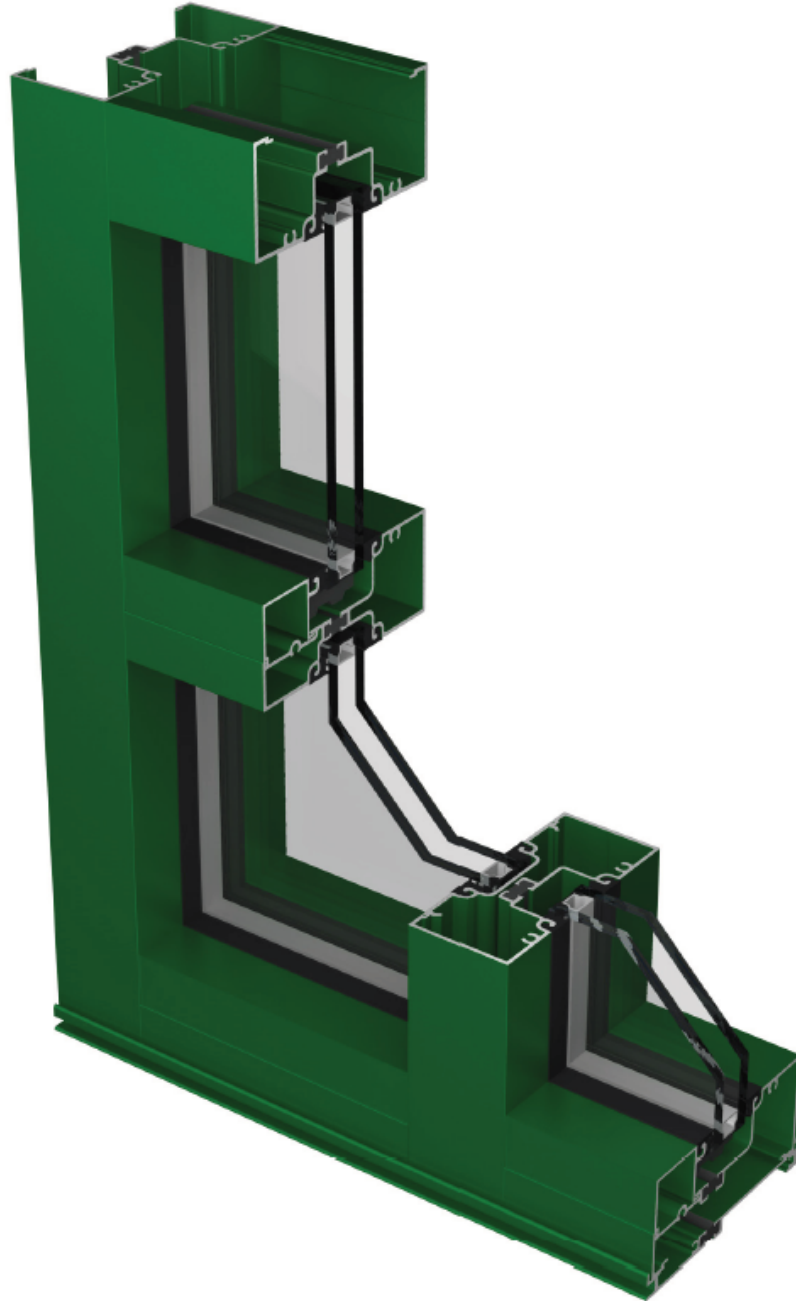

14000 SERIES STOREFRONT

INSTALLATION INSTRUCTIONS

3056 Walker Ridge Dr. NW, Suite G • Walker, MI 49544 • 800-866-2227

BLANK

TABLE OF CONTENTS



GENERAL CONSTRUCTION NOTES	5
PARTS LIST	6-18
QUICK REFERENCE CHECKLIST	19
ELEVATION DETAILS	20-22
FRAME FABRICATION	
Step 1 Determine Frame Size	23
Step 2 Cut Material to Size	23
Step 3 Sill Flashing	24
Step 4 Verticals & Closer Pockets for Horizontals	25-26
Step 5 Horizontals for Shear Block Assembly	27
Step 6 Shear Block Modification	28
Step 7 Steel Stiffener	29
Step 8 Corner Sill Flashing Fabrication	30
Step 9 Corner Sill Flashing Installation	31
Step 10 Corner Frames	32
FRAME ASSEMBLY	
Step 11 Sill Flashing End Dams.....	33
Step 12 Optional High Sidelite Base.....	34-36
Step 13 Optional Sidelight Base.....	37
Step 14 Assemble Frames	38-42
FRAME INSTALLATION	
Step 15 Sill Flashing Installation	43
Step 16 Sill Flashing Splicing	44
Step 17 Install Frames	45-46
Step 18 Frame at Entrance	47
GLAZING	
Step 19 Glazing Preparation	48
Step 20 Installing Glazing Units	49-51
CORNER CONDITIONS for ROTATIONAL MULLION	
Sill Flashing Fabrication & Installation	52-53
OPTIONAL THERMAL ENHANCEMENT	
Alternate Details	54

BLANK



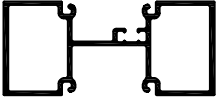
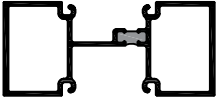
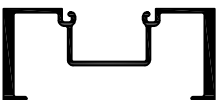
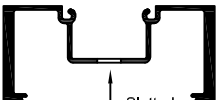
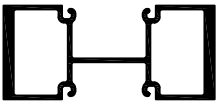
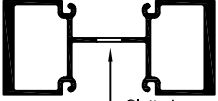
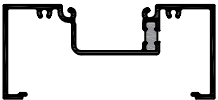

GENERAL CONSTRUCTION NOTES

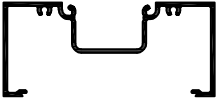
1. These instructions cover typical product application, fabrication, installation and standard conditions and are general in nature. They provide useful guidelines, but the final shop drawings may include additional details specific to the project. Any conflict or discrepancies must be clarified prior to execution.
2. Materials stored at the job site must be kept in a safe place protected from possible damage by other trades. Stack with adequate separation so materials will not rub together and store off the ground. Cardboard or paper wrapped materials must be kept dry. Check arriving materials for quantity and keep a record of where various materials are stored.
3. For cold weather installations, glazing materials (including but not limited to glazing gaskets, isolators and gaskets for air seals and expansion mullions) can become more rigid and thus more difficult to install. These materials should be installed at temperatures above 40°F for proper system performance and ease of installation. A hot box may be required to warm the glazing materials prior to installation. Allow glazing materials to lay flat at 50°F minimum temperature for several hours prior to installing.
4. All field welding must be done in accordance with AISC guidelines. All aluminum and glass should be shielded from field welding to avoid damage from weld splatter. Results will be unsightly and may be structurally unsound. Advise general contractor and other trades accordingly.
5. Coordinate protection of installed work with general contractor and/or other trades.
6. Coordinate sequence of other trades which affect framing installation with the general contractor (e.g. fire proofing, back up walls, partitions, ceilings, mechanical ducts, HVAC, etc.).
7. General contractor should furnish and guarantee bench marks, offset lines and opening dimensions. These items should be checked for accuracy before proceeding with erection. Make certain that all adjacent substrate construction is in accordance with the contract documents and/or approved shop drawings. If not, notify the general contractor in writing before proceeding with installation because this could constitute acceptance of adjacent substrate construction by others.
8. Isolate all aluminum to be placed directly in contact with masonry or other incompatible materials with a heavy coat of zinc chromate or bituminous paint. Fasteners attaching framing to building structure are typically not provided by Tubelite.
9. Sealant selection is the responsibility of the erector, installer and/or glazing contractor and must be approved by the sealant manufacturer with regard to application and compatibility for its intended use. All sealants must be used in strict accordance with the manufacturer's instructions and applied only by trained personnel to surfaces that have been properly prepared.
10. Sealant must be compatible with all materials with which they have contact, including other sealant surfaces. Consult the sealant manufacturer for recommendations relative to shelf life, compatibility, cleaning of substrate, priming, tooling adhesion, environment, temperature, and humidity. Recommend sealant manufacturer perform adhesion "pull test" at "wet" glazing for quality assurance.
11. Drainage gutters and weep holes must be kept clean at all times. Tubelite will not accept responsibility for improper drainage as a result of clogged gutters and weep holes.
12. This product requires clearances at the head, sill and jambs to allow for thermal expansion and contraction as well as construction tolerances. Refer to final distribution drawings for joint sizes. Joints smaller than $\frac{1}{4}$ " may be subject to failure. Consult the sealant manufacturer for proper sizing of joints.
13. All framing members, entrances and other materials are to be installed plumb, level, and true with regard to established bench marks, column center lines, or other working points established by the general contractor and checked by the erector, installer, and/or glazing contractor.
14. After sealant is set and a representative amount of the wall has been glazed (500 square feet or more), run a water hose test to check installation. On large projects, a hose test should be repeated during glazing operation. This testing should be conducted in accordance with AAMA 501.2 specifications.
15. Cleaning of exposed aluminum surfaces should be done per AAMA recommendations.
16. Care must be taken when assembling aluminum framing components. Over tightening any fastener may cause stripping or fastener failure. Tubelite recommends the use of clutched drivers to provide satisfactory tightening of the screw while preventing over torque. The use of impact drill motors is not recommended due to the absence of a clutch device.
17. Check www.tubeliteinc.com for any installation instruction updates.

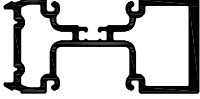
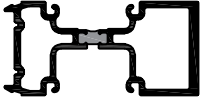

VERTICAL EXTRUSIONS

SHAPE	DESCRIPTION	PART No.
	Tubular Vertical Mullion	E1400
		T1400
	Open Back Heavy Duty Vertical Mullion	E1435
 <p style="text-align: center;">↑ Slotted</p>		T1435
	Heavy Duty Tubular Vertical Mullion	E1430
 <p style="text-align: center;">↑ Slotted</p>		T1430
	Open Back Vertical Mullion for Steel Reinforcement	T14261
	Standard Open Back Head/Jamb/Vertical	T14441
	Open Back (Non-Thermal) Head/Jamb/Vertical	E14141

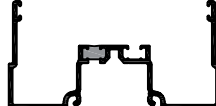

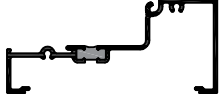

VERTICAL EXTRUSIONS

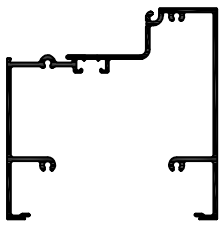
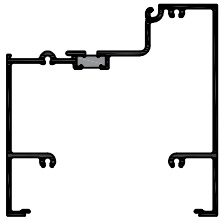
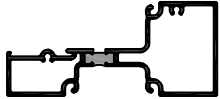
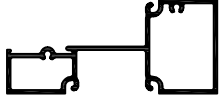
SHAPE	DESCRIPTION	PART No.
	Sun Shade Vertical Mullion	E14249
		T14249
	Female Half (Non-Thermal) Expansion Mullion	E14106
	Male Half (Non-Thermal) Expansion Mullion	E14107
	Female Half (Thermal) Expansion Mullion	T24346
	Male Half (Thermal) Expansion Mullion	T24336



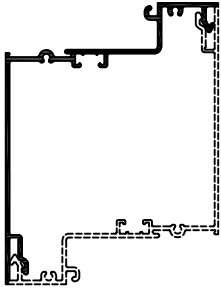
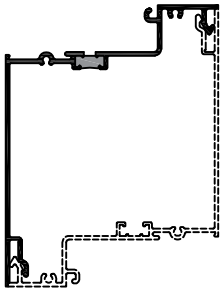



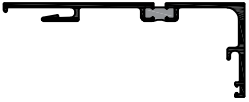
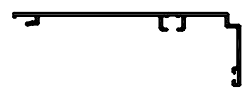

HORIZONTAL EXTRUSIONS

SHAPE	DESCRIPTION	PART No.
	Open Back Horizontal/Sill	T14240
		E14140
	4 1/2" x 4 1/2" Horizontal/Sill	E14047
		T14047
	Standard Intermediate Tubular (Thermal) Horizontal/Sill	T14143
	Tubular (Non-Thermal) Horizontal/Sill	E14103

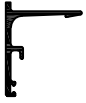
HORIZONTAL EXTRUSIONS

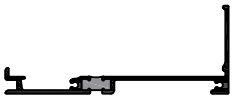
SHAPE	DESCRIPTION	PART No.
	<p>4 ½" X 6" Self Mating Horizontal</p>	<p>E14054</p>
		<p>T14054</p>
	<p>Horizontal Glass Stop</p>	<p>E14104</p>
	<p>Perimeter Member for Curving <i>Used with P1707 clip</i></p>	<p>E14288</p>
	<p>Perimeter Face for Curving</p>	<p>E14289</p>

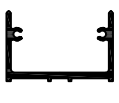

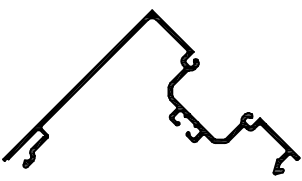
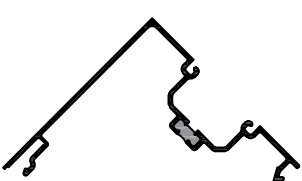
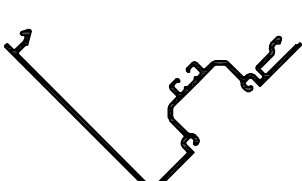
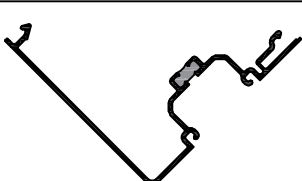
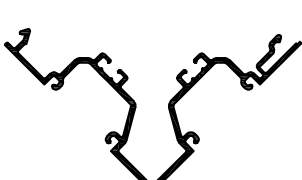
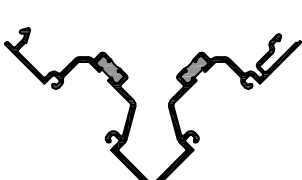
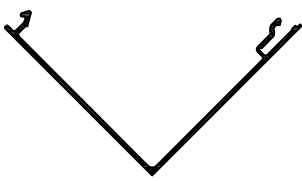

**SIDELITE BASE, SILL FLASHING, and
HEAD RECEPTOR EXTRUSIONS**

SHAPE	DESCRIPTION	PART No.
	Head Receptor	E14129
		T14129
	Lightweight Head Receptor	E14090
		T14090
	Head Receptor Snap Stop	E14130
	Lightweight Head Receptor Snap Stop	E14091
	Sill Flashing (Standard)	T14259
	Sill Flashing (Optional)	T14055
	Sill Flashing (Standard)	E14059
	Sidelite Base Anchor Shoe	E14027
	Head Receptor (Optional)	E45116
	4" X 2 1/2" Sidelite Base	E14026



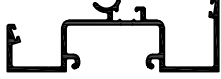



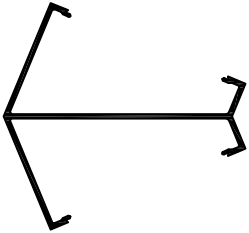











CORNER EXTRUSIONS

SHAPE	DESCRIPTION	PART No.
	<p>90° Single Pocket Corner Mullion Half</p>	<p>E14118</p>
		<p>T14118</p>
	<p>90° Single Pocket Corner Mullion Half</p>	<p>E14119</p>
		<p>T14119</p>
	<p>90° Dual Pocket Corner Mullion Half</p>	<p>E14110</p>
		<p>T14110</p>
	<p>90° No Pocket Corner Mullion Half</p>	<p>E45110</p>







CORNER EXTRUSIONS

SHAPE	DESCRIPTION	PART No.
	Rotational Corner Mullion Half	E14246
		T14246
	Rotational Corner Mullion Post	E14247
		T14247
	45°/135° Corner Mullion Post	E45005

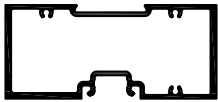





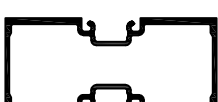
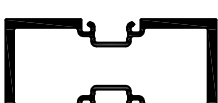
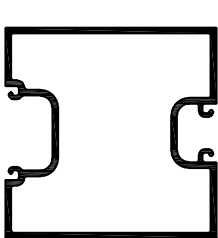
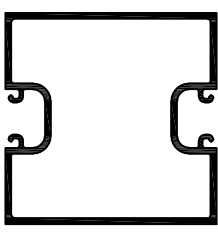

POCKET FILLERS and GLAZING ADAPTOR EXTRUSIONS

SHAPE	DESCRIPTION	PART No.
	Flat Snap-In Filler Full length extrusion. Use at perimeter with non-thermal storefront only	E4543
	Flat Snap-In Filler 6" Aluminum anchor plate. Use at head and jamb anchor points as required for non-thermal storefront only	P1745
	Flat Snap-In PVC Filler Use between anchor points at head and jamb as required	P4543
	Flat Snap-In PVC Filler (Standard) Use at head and sill of frame. See pages 41 & 55 for usage	P4543A
	Flat Snap-In Filler Full length extrusion. Use at perimeter with thermal storefront only	T6251
	Flat Snap-In Filler 6" Aluminum anchor plate. Use at head and jamb anchor points as required for thermal storefront only	P1130
	Standard Shallow Pocket Closure	A244040
	Standard Deep Pocket Closure	A245050
	Closer Pocket Filler (Optional)	T14442
	Standard Closer Pocket Filler for E14000	E14445
	Closer Pocket Filler (Optional)	T14445
	Standard Deep Closer Pocket Filler for E14000	E14022
	Deep Closer Pocket Filler (Optional)	T14022
	Snap-In Sidelite Base Adaptor	E14248
		T14248
	Snap-In 1" Pocket Filler	E1411
	Snap-In 1" PVC Pocket Filler	P4563
	Snap-In $\frac{1}{4}$ " Glazing Adaptor	E14036
	Snap-In $\frac{1}{2}$ " Glazing Adaptor	E14061

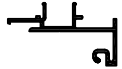



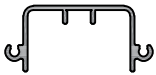



DOOR FRAME EXTRUSIONS

SHAPE	DESCRIPTION	PART No.
	Standard Tubular Door Header	E14124
	Tubular Door Header	E14125
	Open Back Center Hung Door Jamb	E1438
	Open Back Door Jamb	E14144
	Tubular Door Jamb	E14021
	Heavy Duty Tubular Door Jamb	E14121
	Tubular Intermediate Door Jamb	E14145
	Heavy Duty Tubular Intermediate Door Jamb	E14245
	4 1/2" x 4 1/2" Tubular Door Jamb	E14250
	4 1/2" x 4 1/2" Tubular Intermediate Door Jamb	E45009

DOOR FRAME ACCESSORIES EXTRUSIONS

SHAPE	DESCRIPTION	PART No.
	Snap-In Door Stop	E4531
	Offset Arm Door Stop	E2298
	Applied Transom Gutter	E1414
	Snap-In Transom Gutter	E4013
	Applied Transom Gutter	E14024
	Gutter Glass Stop for E1414 & E4013	E1415
	Gutter Glass Stop for E14024	E14025
	Shear Block For Head Members	P1133
	Shear Block For Horizontal and Sill Members	P1134

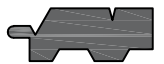

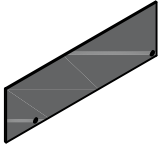
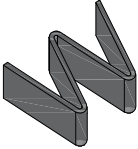
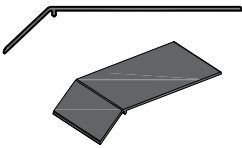
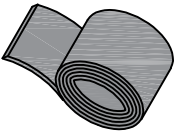
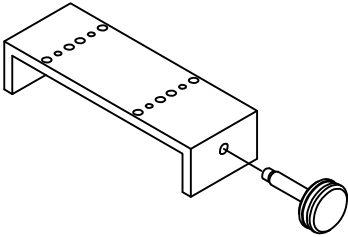

GASKETS and SETTING BLOCKS

SHAPE	DESCRIPTION	PART No.
	Roll-In Glazing Gasket for 1" Glass (Standard)	P2728
	Roll-In Glazing Gasket for 1 $\frac{1}{8}$ " Glass	P487
	Roll-In Glazing Gasket for Undersized Glass	P2428
	Wiper Gasket for One-Piece Head Receptor and Rotational Vertical Mullion	P1221
	Bulb Gasket for Two Piece Head Receptor and Stop	P2511
	$\frac{3}{16}$ " Setting Block at Inside Glaze Horizontals Only	P2400
	Setting Block (Standard)	P1131 (Silicone) P1132 (EPDM)
	Face Clip for E14288 & E14289	P1707

WATER CONTROL ACCESSORIES and DRILL GUIDE

SHAPE	DESCRIPTION	PART No.
	<p>Sill Flashing End Dam</p>	<p>P2455</p>
	<p>EPDM AntiWalk "W" Block (Optional) (Use at Deep Pockets on Verticals and Jambs)</p>	<p>P1917</p>
	<p>Water Diverter (Use at Intermediate Horizontals)</p>	<p>P1135</p>
	<p>Silicone Splice Sleeve (Standard) (Use at T14055, E14059, and T14259 Sill Flashing)</p>	<p>P3444</p>
	<p>Drill Guide (for screw spline and shear clip assembly)</p>	<p>P1139</p>

SYSTEM SCREWS

SHAPE	DESCRIPTION	PART No.
	#10 1 ³ / ₄ " type B Philips Pan Head (Fastens shear block to verticals)	S009
	#12 x ³ / ₄ " Philips Flat Head (Fastens head member to shear block & sidelite base to P1137 anchor)	S149
	#10 x ¹ / ₂ " Philips Truss Head (Fastens horizontal and sill to shear block & P1137 anchor to vertical)	S191
	#8 x ³ / ₈ " type A Philips Pan Head (Fastens end dam to sill flashing)	S196
	#10-24 x 1" IND HEX Head Type F (Screw spline frame assembly screws)	S449

OPTIONAL TUBE MEMBERS

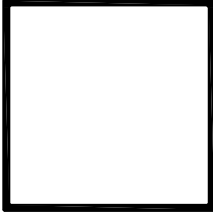
SHAPE	DESCRIPTION	PART No.
	2" x 4 ¹ / ₂ " x ¹ / ₈ " Tube	E1451
	4 ¹ / ₂ " x 4 ¹ / ₂ " x ¹ / ₈ " Tube	E0133

QUICK REFERENCE CHECKLIST

1. Make sure the opening is square and the caulk joints are $\frac{1}{4}$ " minimum around the frame. Note: Frames that utilize the T14259 sill flashing must have a minimum of $\frac{3}{8}$ " caulk joint at head.
2. Ensure surfaces that will be sealed are free of contaminants that can lead to adhesion issues.
3. Sill flashing must be properly shimmed and level from left to right and front to back for proper drainage.
4. A continuous line of sealant must be applied between the sill and the top interior leg of the sill flashing.
5. Check that all weeps and baffles (if required) conform to the locations and sizes called out in these instructions.
6. Ensure that sill flashing weep holes are not plugged by the perimeter seal.
7. A sill flashing splice is needed in openings larger than 24 feet. Follow instructions for installing and sealing.
8. End dams must be installed and sealed onto the sill flashing. Fasteners used must also be sealed.
9. Where the sill flashing abuts a door jamb, the jamb pocket cavity must be completely sealed to dam this area.
10. Cap seal any exposed anchor or screw.
11. Seal ends of horizontal frame members that are joined to vertical members.
12. Water diverter installation and sealing is critical. Check installation against instructions to ensure conformity.
13. Apply sealant between all corner gasket joints.
14. Glass bites must be equal on all sides.
15. Double check anchor size and location against installation instructions or approved shop drawings.
16. Ensure that interior seal is married to sill flashing interior leg.
17. Field modify P4543a snap-in PVC filler at the sill to clear the anchors in the sill flashing.
See pages 41 & 55

GLASS SIZE CALCULATION

Width tolerance = + 0", - $\frac{1}{16}$ "

Typical Framing:

Glass Width = D.L.O plus $\frac{3}{4}$ "

Glass Height = D.L.O plus $\frac{3}{4}$ "

Transoms with Sash:

Glass Width = Pocket filler D.L.O plus $\frac{3}{4}$ "

Glass Height = Pocket filler D.L.O plus $\frac{3}{4}$ " (Ref. Fig.19.1)

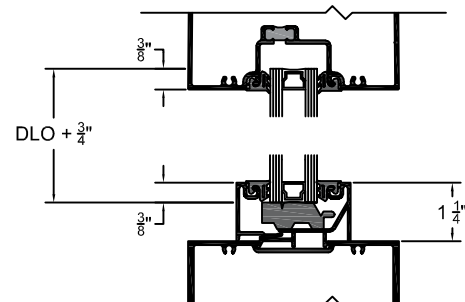

VERTICAL D.L.O. at SASH
Fig.19.1

TYPICAL ELEVATION with DETAILS

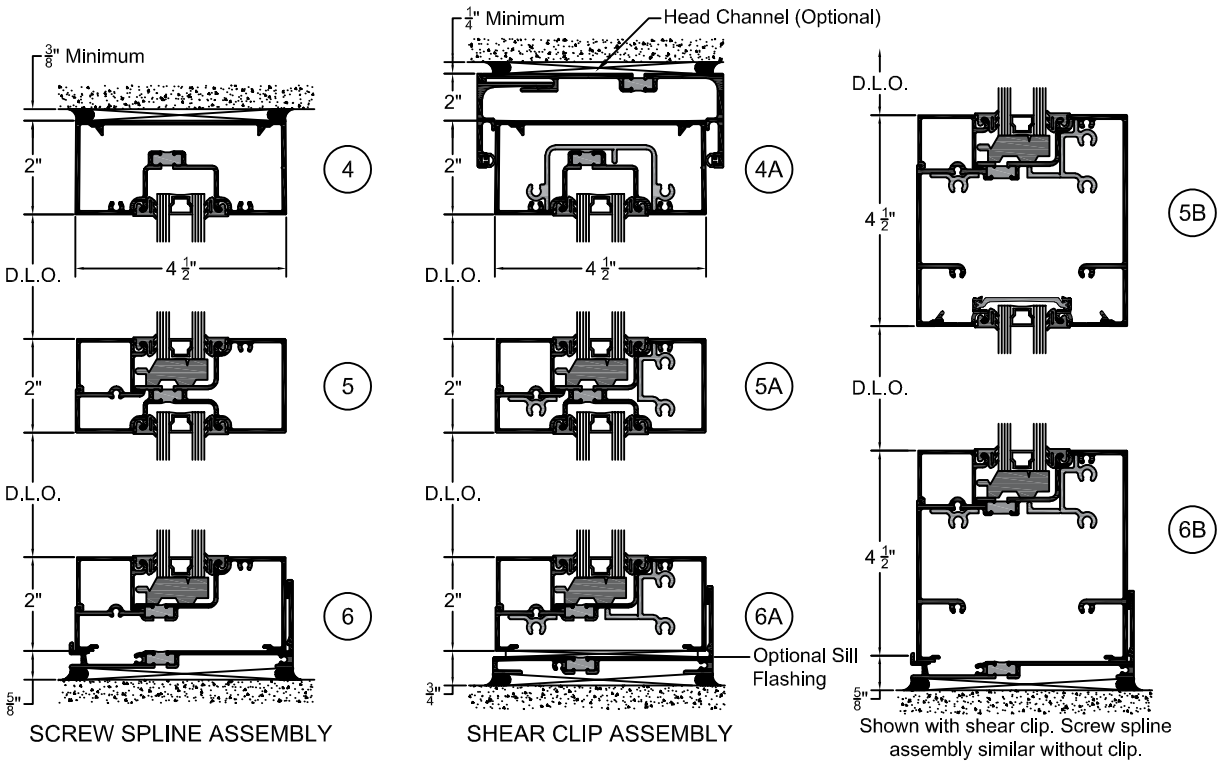
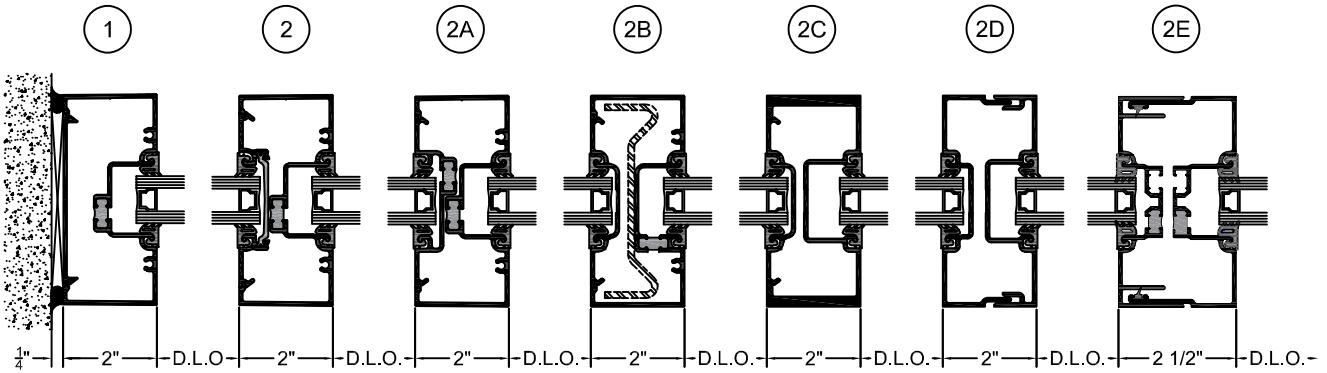
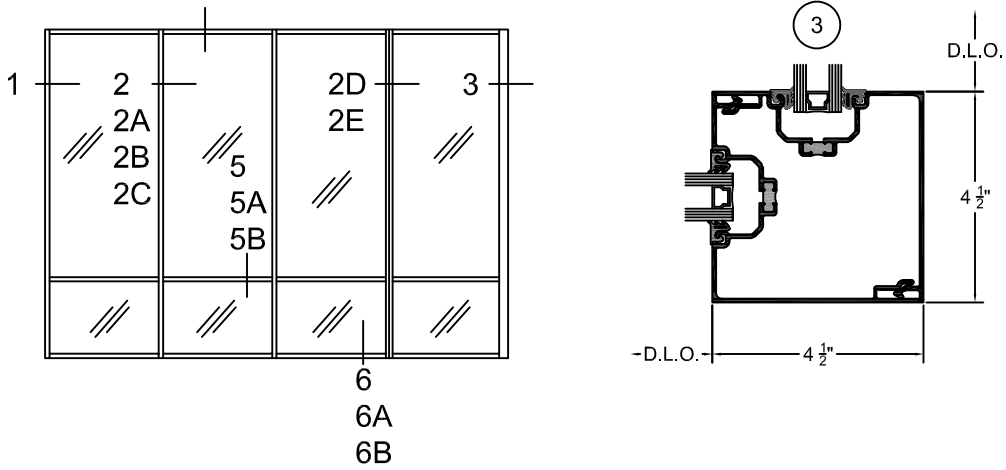

DOOR FRAME ELEVATION with HORIZONTAL DETAILS

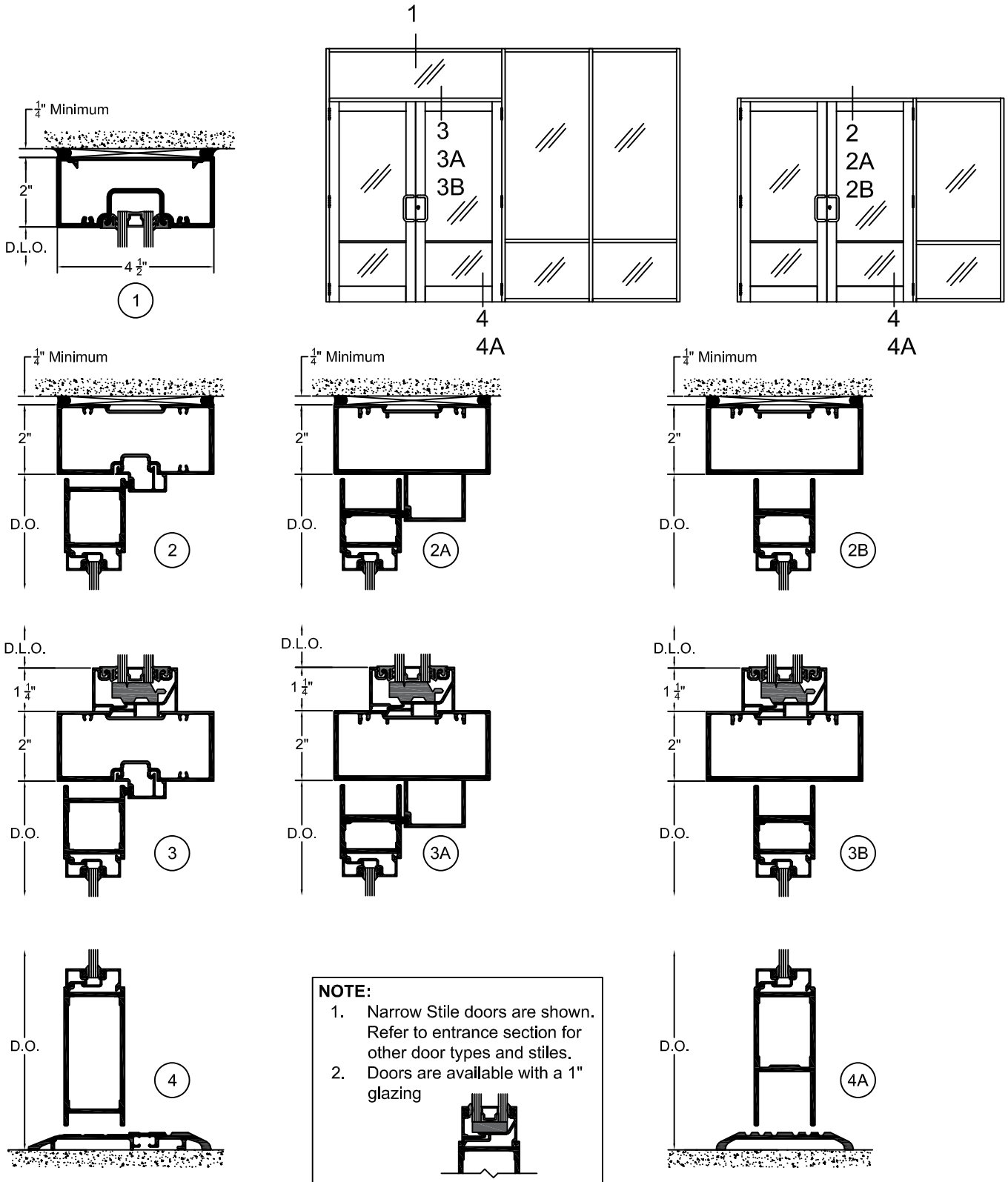

**DOOR FRAME ELEVATION
with VERTICAL DETAILS**

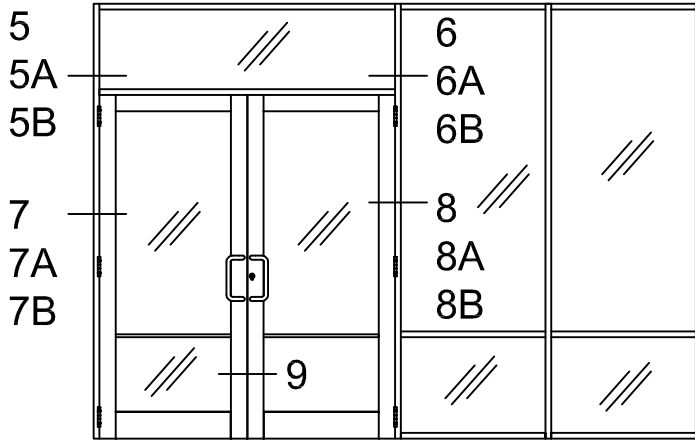

NOTE:

1. Narrow Stile doors are shown. Refer to entrance section for other door types and stiles.
2. Doors are available with a 1" glazing

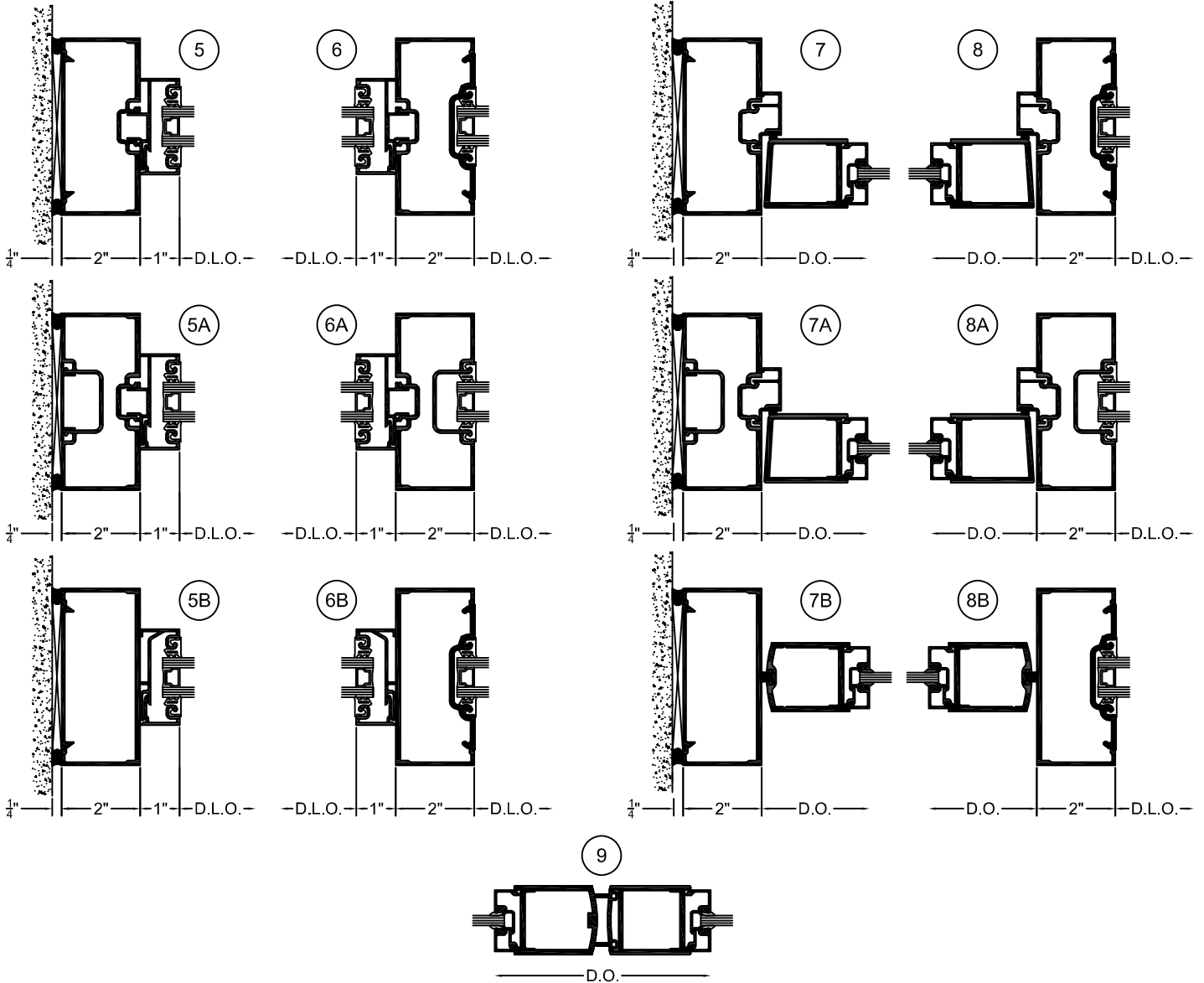
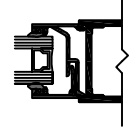

FRAME FABRICATION

NOTE: Non-thermal extrusions are shown in these instructions for clarity. Fabrication and installation of thermal members are the same.

Step 1: Determine Frame Size

Frame Width

- A. Make sure the opening is square and plumb. Measure each diagonal of the opening. **SEE Fig.23.1.**
- B. Measure the width of the opening at the top, middle, and bottom. Select the smallest of these dimensions and subtract the left and right caulk joint width per approved shop drawings ($\frac{1}{4}$ " min caulk joint at each jamb). **SEE Fig.23.2.**

Frame Height

- C. Measure the height of the opening at several points along the entire width of the opening. Select the smallest of these dimensions and subtract the top and bottom caulk joint height per approved shop drawings ($\frac{1}{4}$ " minimum caulk joint at sill. At head, caulk joint can be $\frac{1}{4}$ " using T14055 or similar flashing. When using T14259 or E14059 sill flashing, head caulk joint must be $\frac{3}{8}$ ") **SEE Fig.23.3.**

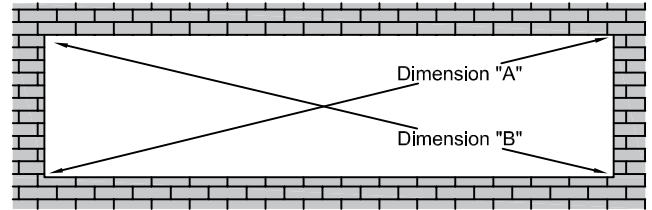

Fig.23.1

Dimension "A" = "B"

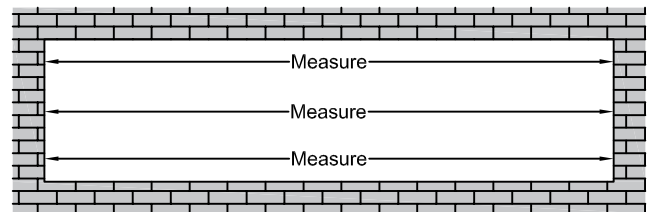

Fig.23.2

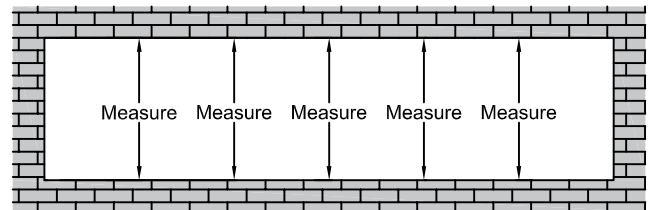

Fig.23.3

Step 2: Cut Material to Size

Note: Door framing material comes cut to size from the factory. In cases of door frames with transoms, the door jambs must be cut down in the field to size and head member attached per standard instructions shown within this manual.

Framing Members

- Sill Flashing with Entrance. Door Jamb to End of Frame + $\frac{1}{8}$ " **(SEE Fig. 23.4)**
- Sill Flashing without Entrance..... Frame Width + $\frac{1}{4}$ "
- Verticals..... **See Fig. 23.4**
- Head ReceptorFrame Width + $\frac{1}{4}$ "
- Head Receptor Snap Stop.....Frame Width + $\frac{1}{4}$ "
- Head, Horizontal & Sill.....D.L.O.
- Horizontal & Sill Glass Stops..... D.L.O. - $\frac{1}{32}$ "
- Closure Pockets at Verticals..... **See Fig. 23.4**
- Glazing Adaptors..... D.L.O. - $\frac{1}{32}$ "
- Snap-In Fillers.....Refer to Approved Shop Drawings

Accessories

- Exterior Gasket..... D.L.O. + Allowance*
- Interior Gasket..... D.L.O. + Allowance*

*Allowance = $\frac{1}{8}$ " extra length per foot of D.L.O.

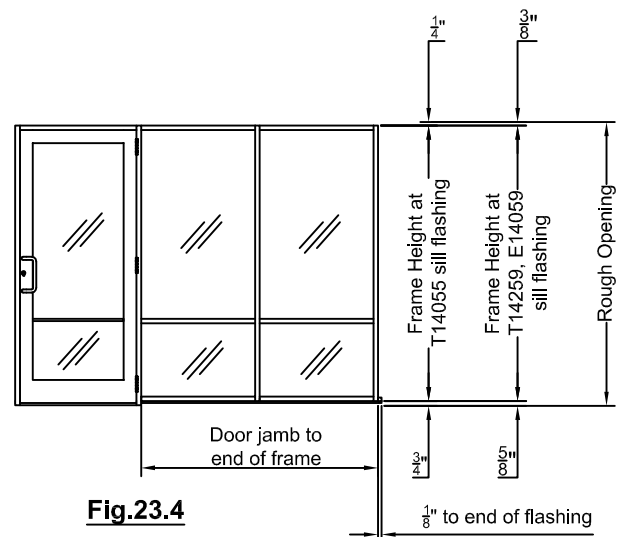

Fig.23.4

Sill Flashing Note:

For openings wider than 24', the sill flashing must be spliced at the center line of a D.L.O. every twelve to fifteen feet. Splice joint should be $\frac{3}{8}$ " wide. **SEE Step 16, Page 44** for sill flashing splice details.

FRAME FABRICATION

Step 3: Fabricate Sill Flashing

A. When using T14259 or E14059, drill two $\frac{7}{32}$ " dia. weep holes at 2" and 6" from each side of the verticals

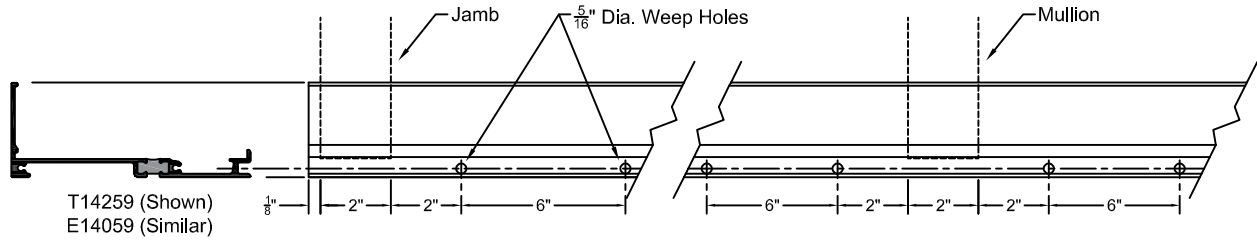
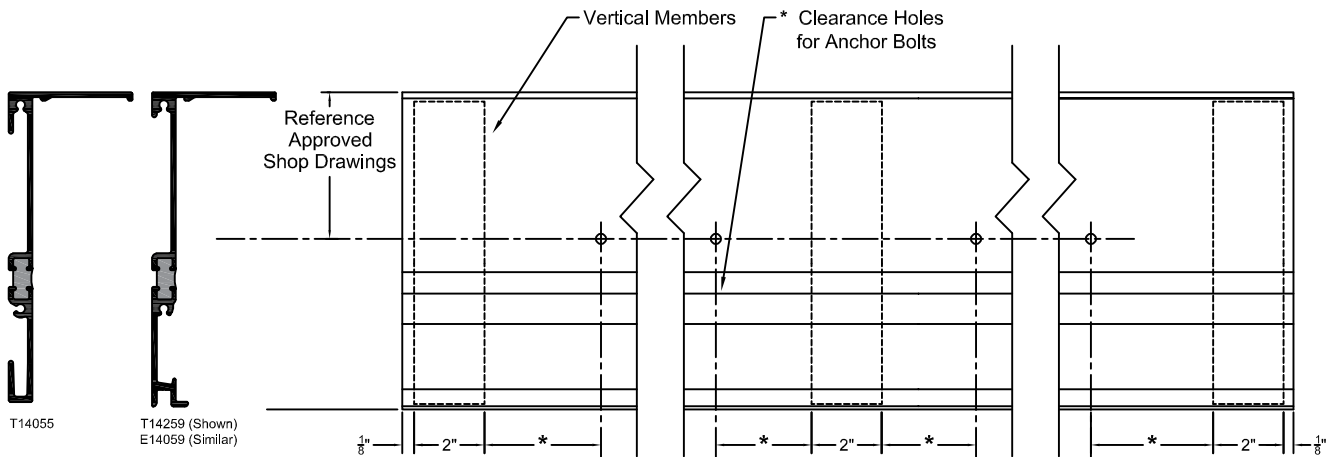

Fig.24.1

B. Drill clearance holes for perimeter anchors. Size and quantity vary per job. Refer to approved shop drawings.

Note: if head receptors are used, follow the same procedure as on the sill flashing



NOTE:
DLO's larger than 42" require an additional anchor hole at mid-point of bay

Fig.24.2

* Reference approved shop drawings for anchor hole sizes, locations, and quantity

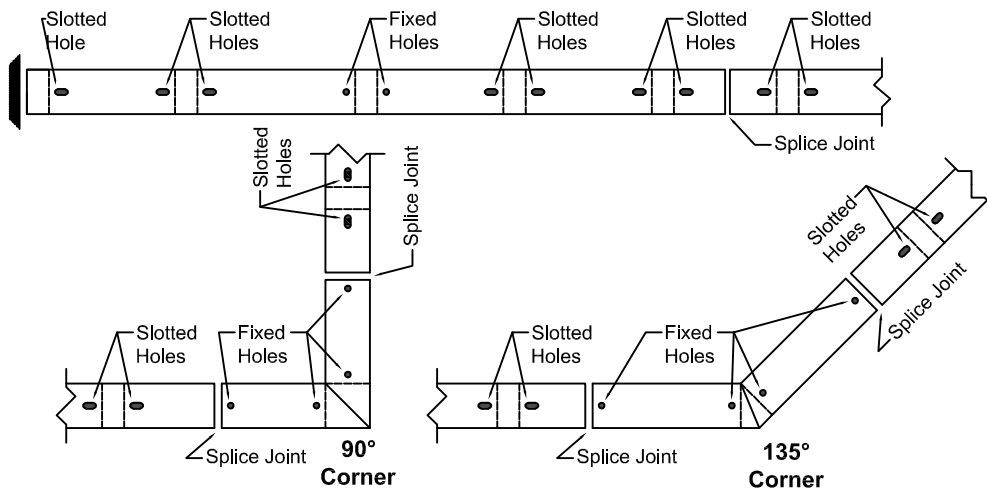

Typical Sill Flashing Anchor Hole Patterns (Head channel similar)
(Refer to approved shop drawings for project requirements)

Fig.24.3

FRAME FABRICATION

Step 4: Fabricate Verticals & Closure Pockets for Horizontals

- A. Drill frame assembly holes in verticals, jambs, & closure pockets with drill fixture P1139
SEE Fig.25.1 & Fig.26.1
- For screw spline assembly, use holes marked 'X' in P1139. **SEE Fig.25.2**
 - For shear block assembly, use holes marked 'Z' in P1139. **SEE Fig.25.2**

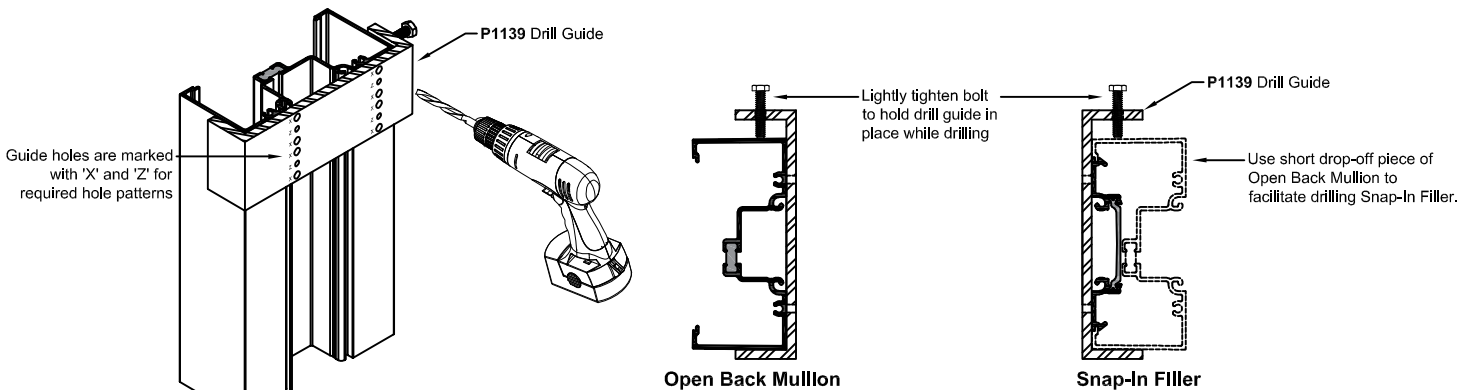
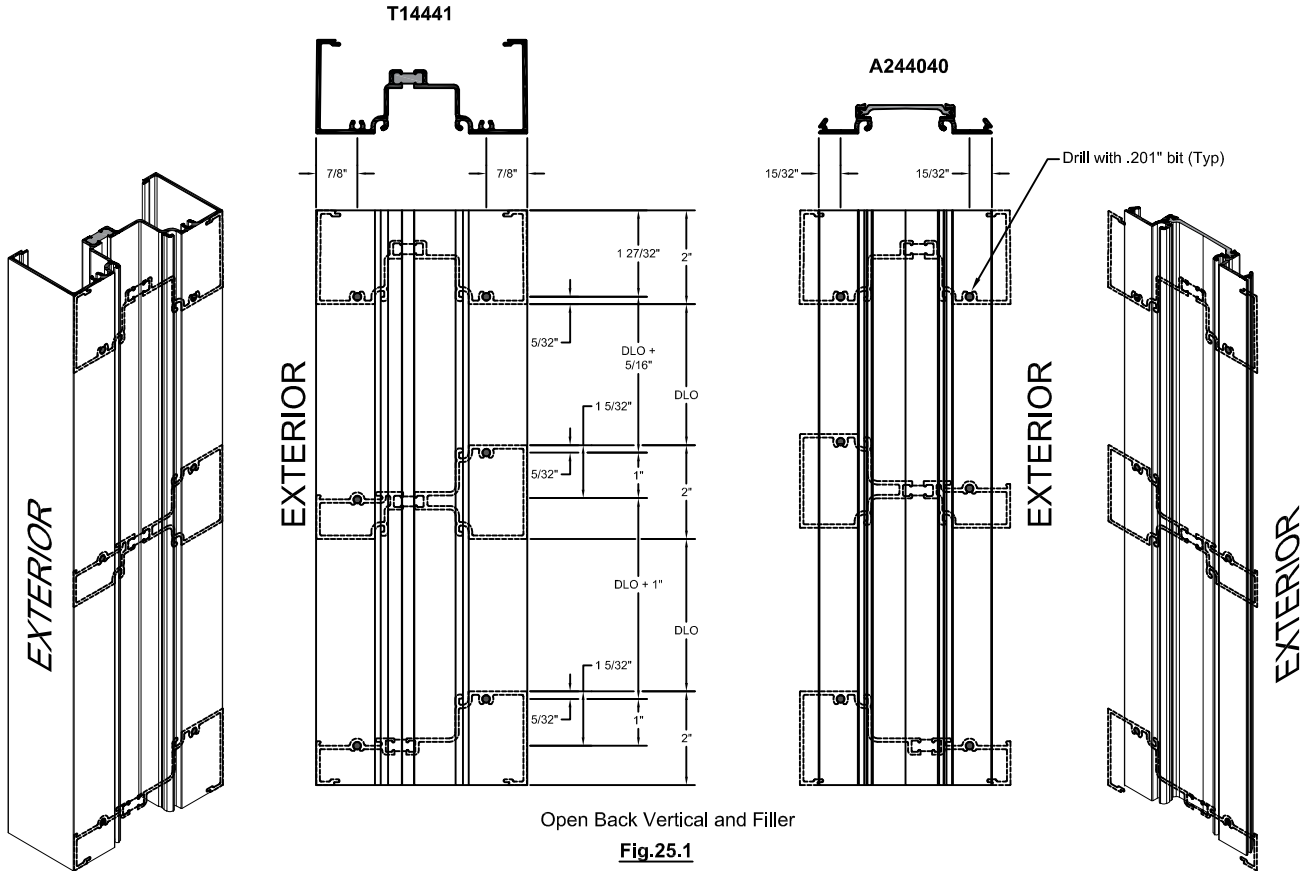

FRAME FABRICATION

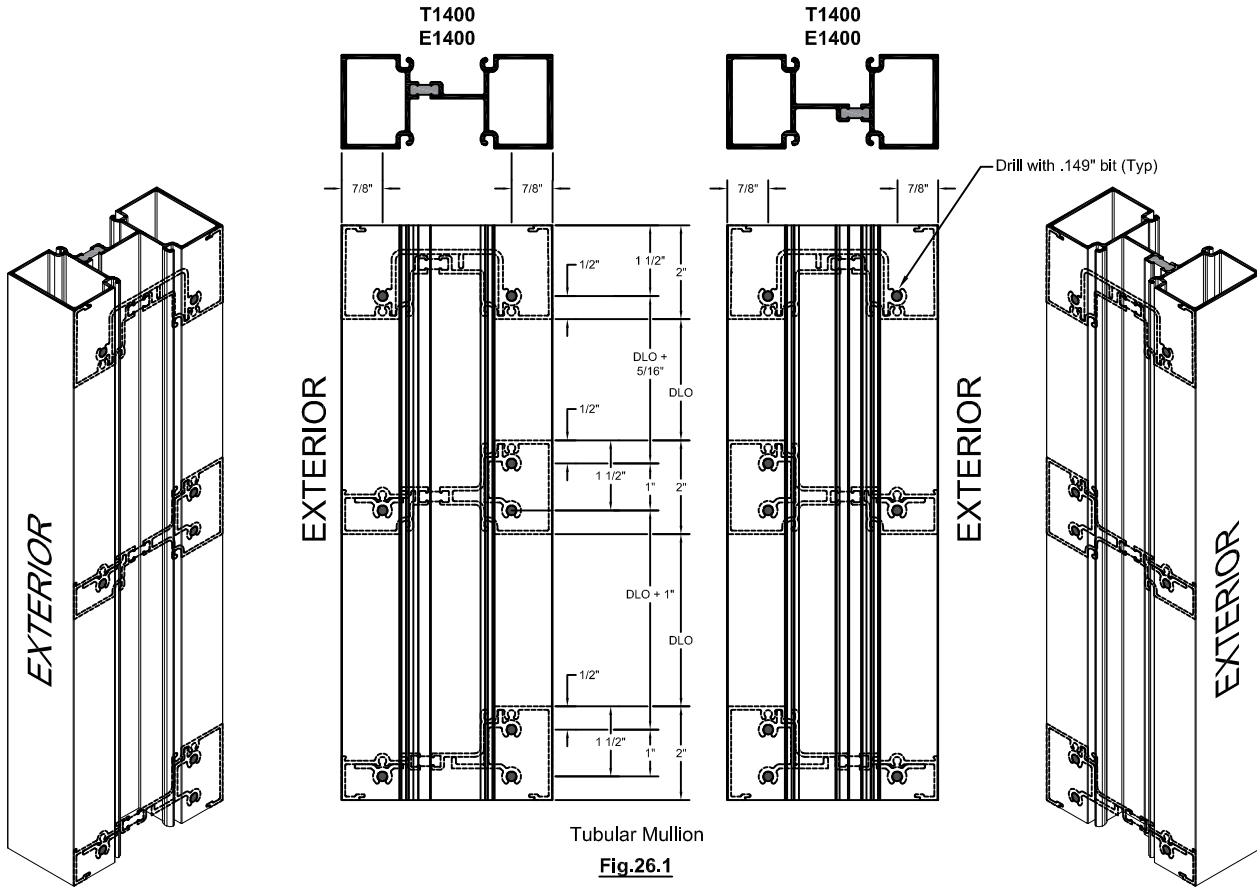

FRAME FABRICATION

Step 5: Fabricate Horizontal Members for Shear Blocks

- A. For shear block assembly, drill .201" dia. holes in the head, horizontal, and sill members as shown in **Fig. 27.1** & **Fig. 27.2** (Head members only to receive countersink hole for flat head screws).

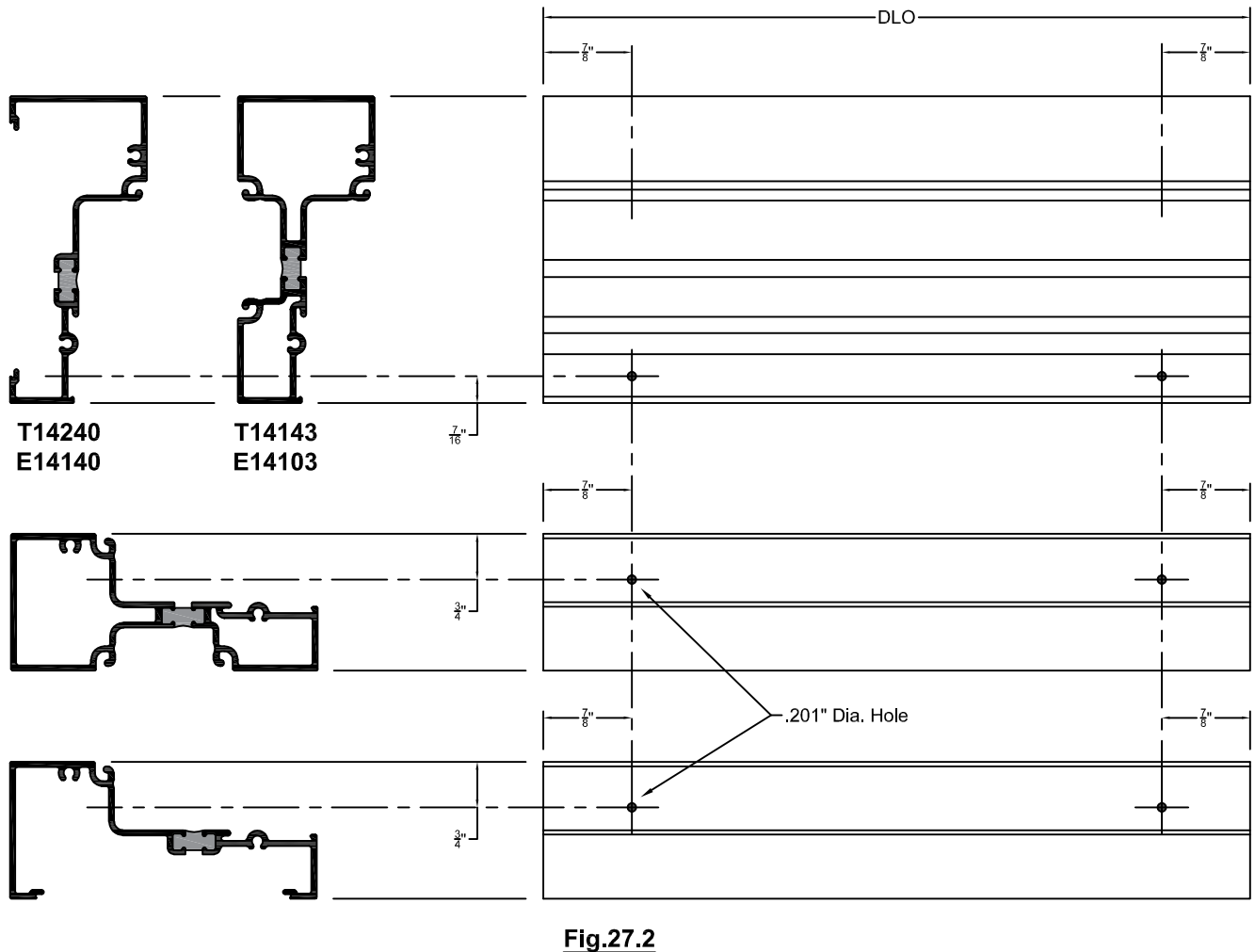
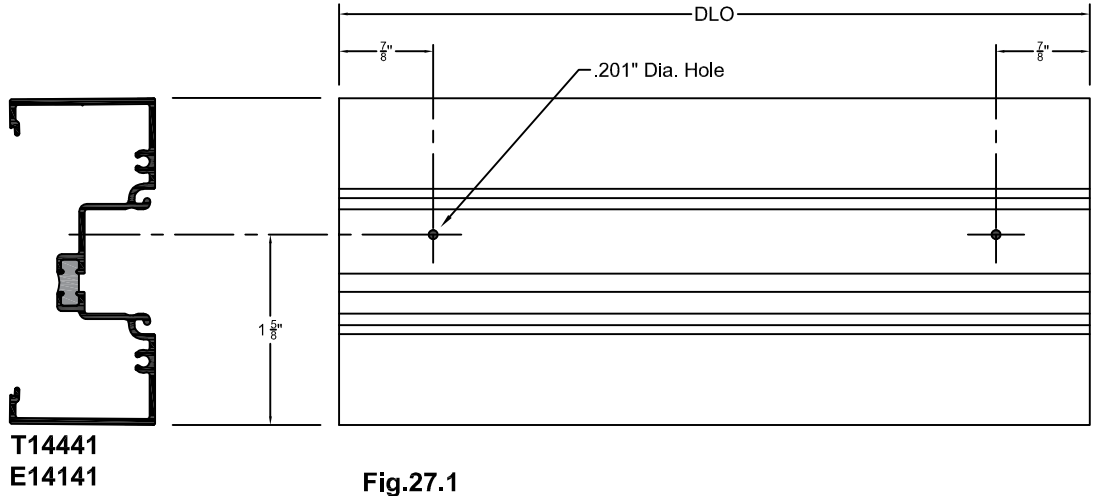

FRAME FABRICATION

Step 6: Fabricate Shear Blocks (As Required)

- A. For shear block assembly, P1134 shear block must be modified
- B. **SEE Fig.28.1 & Fig.28.2** for instructions on modifying for the various horizontal sections

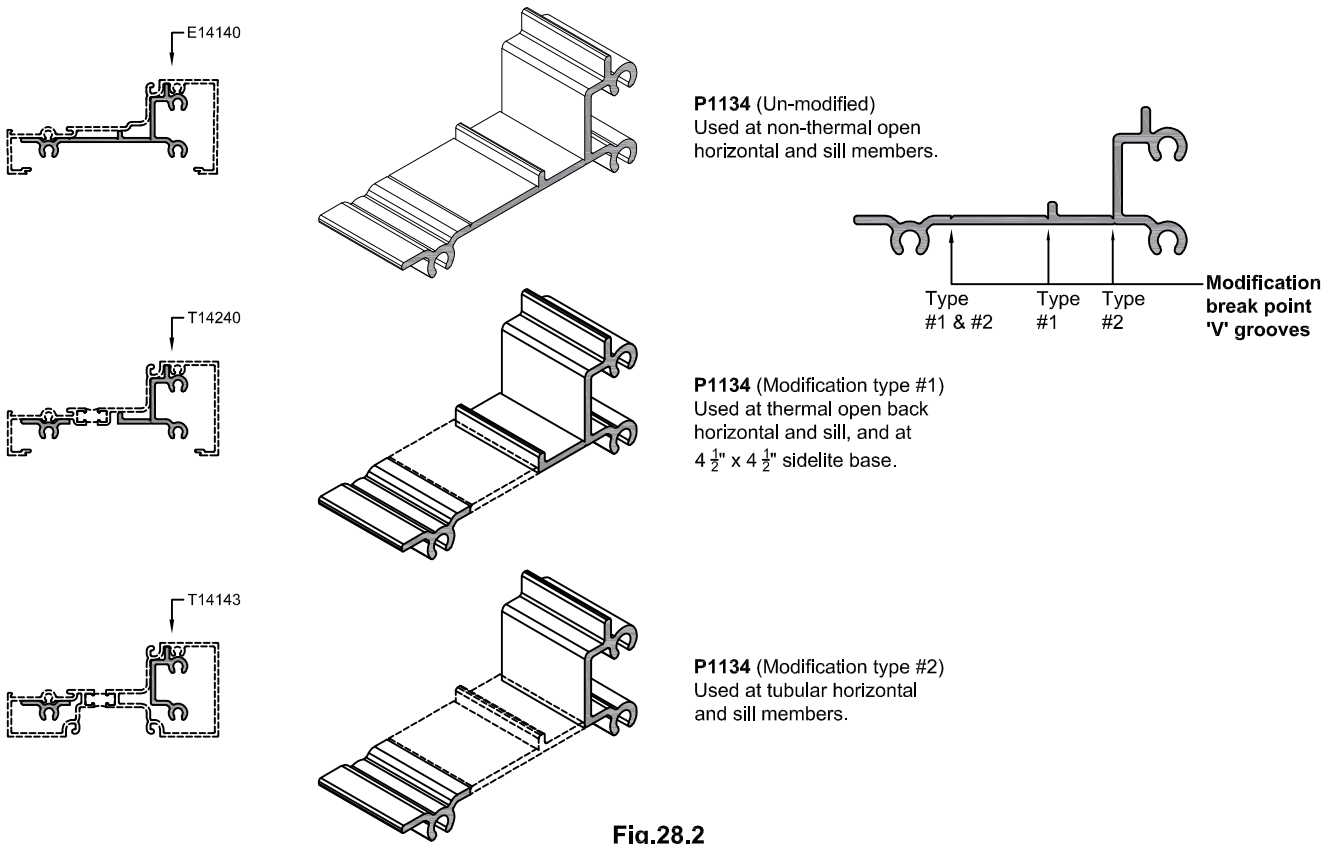
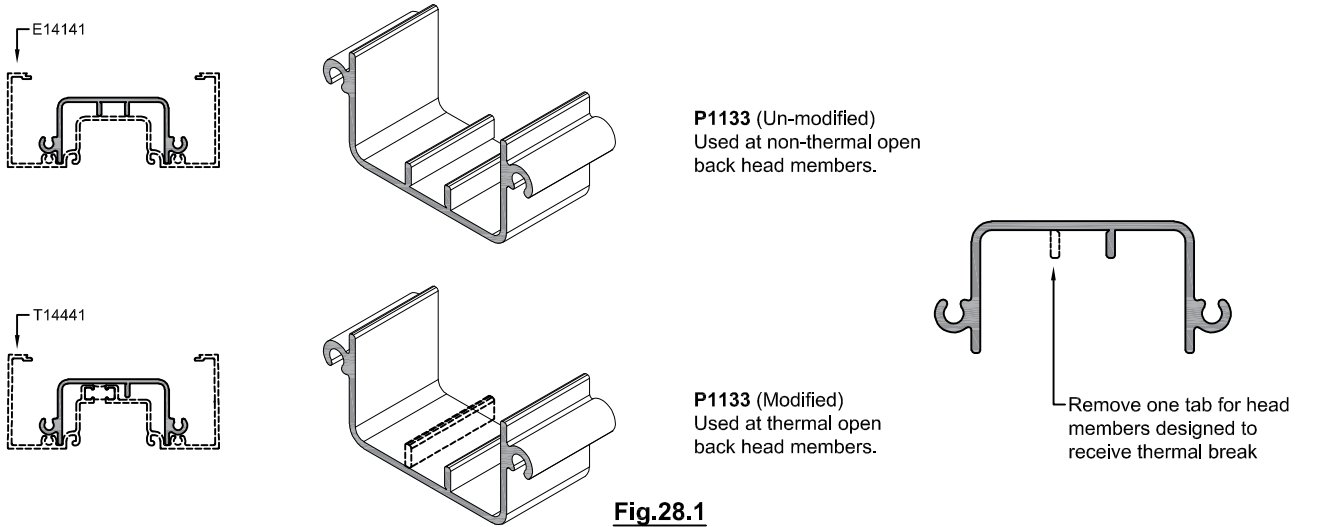

FRAME FABRICATION

Step 7: Steel Stiffener (As Required)

- If P1437 steel stiffeners are required (refer to approved shop drawings), cut 4" shorter than the vertical mullion length. Paint ends to prevent rust.
- Use thermal insulator tape or shim (not by Tubelite) to isolate the steel reinforcement from the vertical members (thermal applications only).
- Drill and countersink clear hole in vertical and tap hole in P1437 steel stiffener for attachment screw. Size and spacing of screw per approved shop drawings.

NOTE:

Use of #10 screw at spacing shown as a general guide. Refer to approved shop drawings or engineer's calculations for specific application.

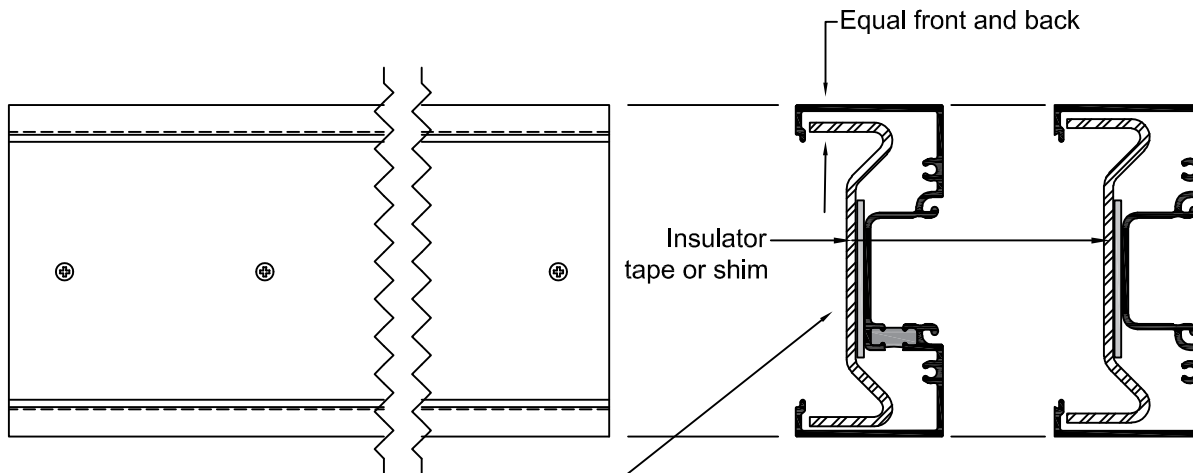
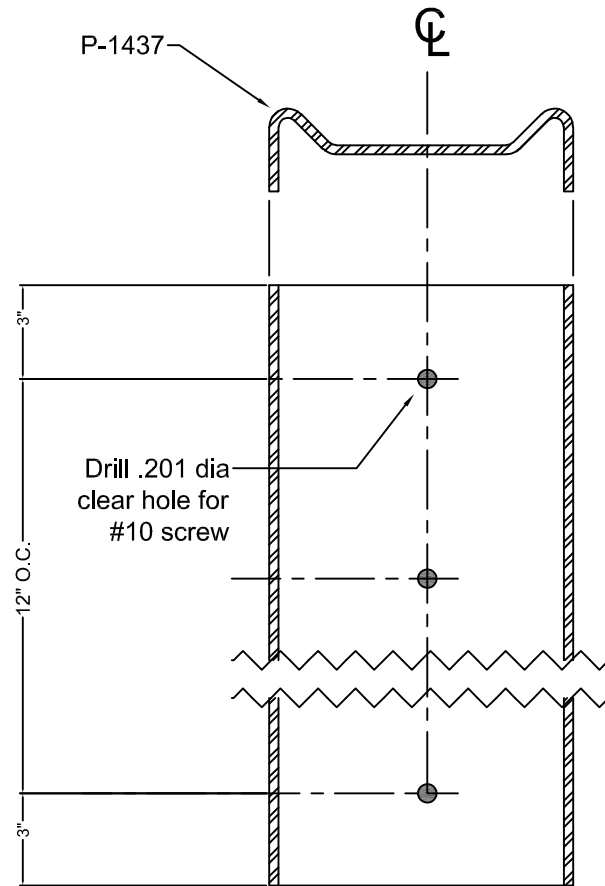

Match drill .154 dia
(drill #23) pilot holes
in mullion

Fig. 29.1

Use thermal insulator tape or shim (Not by Tubelite) to isolate the steel reinforcement from the vertical members

NOTE:

T14442 cannot be used when applying P1437 steel reinforcement.

FRAME FABRICATION

Step 8: Corner Sill Flashing Fabrication

- A. Miter ends of sill flashing as shown in **Figs. 30.1, 30.2, 30.3 & 30.4**. (One left hand and one right hand.)
- B. Drill anchor holes as show.

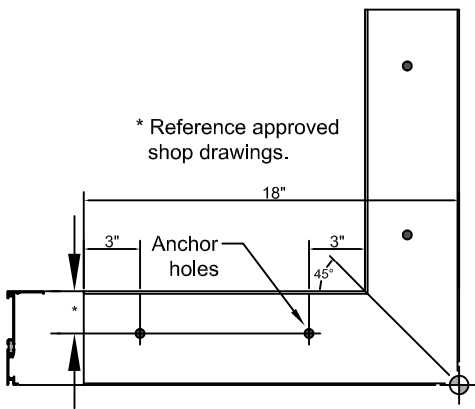

90° OUTSIDE CORNER
Fig.30.1

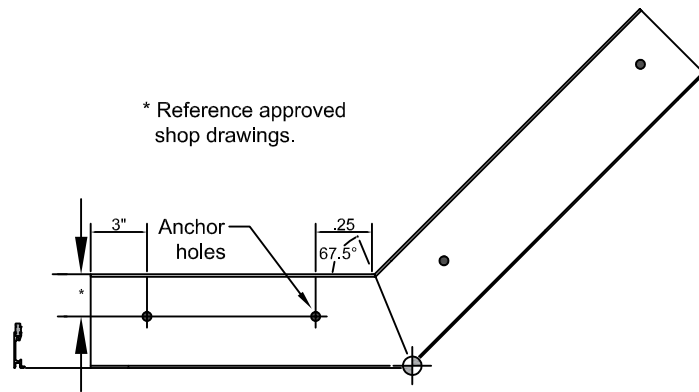

135° OUTSIDE CORNER
Fig.30.2

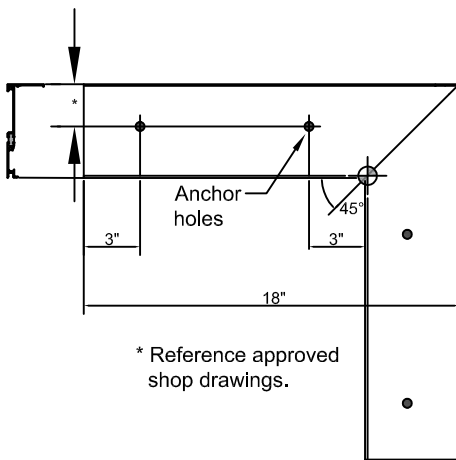

90° INSIDE CORNER
Fig.30.3

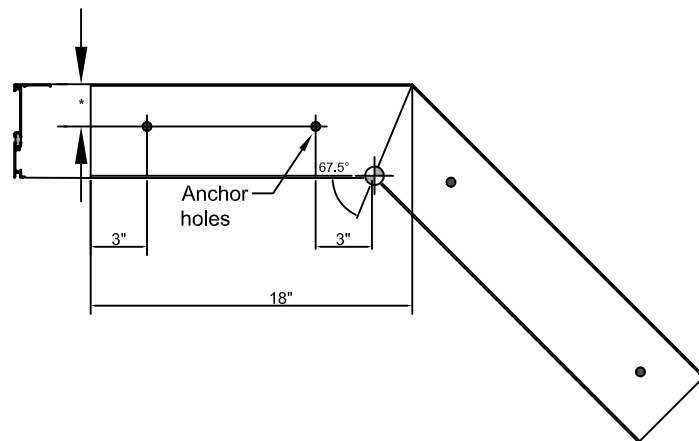

135° INSIDE CORNER
Fig.30.4

FRAME FABRICATION

Step 9: Corner Sill Flashing Installation

- A. Install flashing corner members in place.
- B. Apply sealant full length of mitered joint. See **Fig. 31.2**.
- C. Splice corner flashing to sill flashing using procedures shown on page 44 and **Fig. 44.1**.

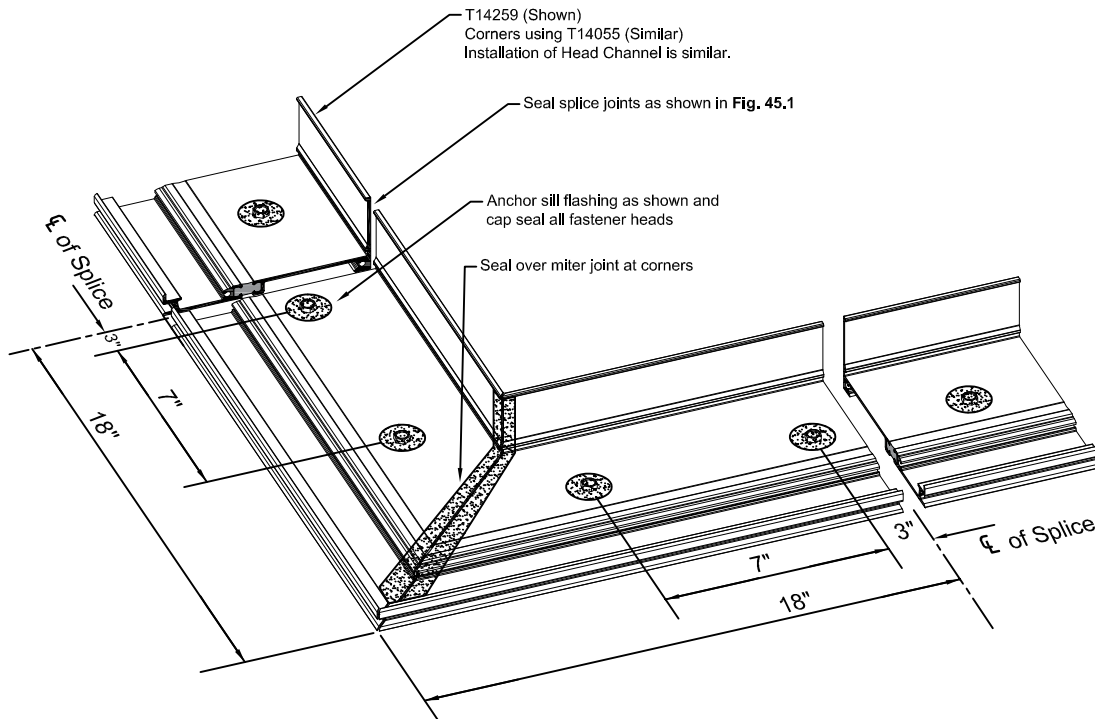

Fig.31.1

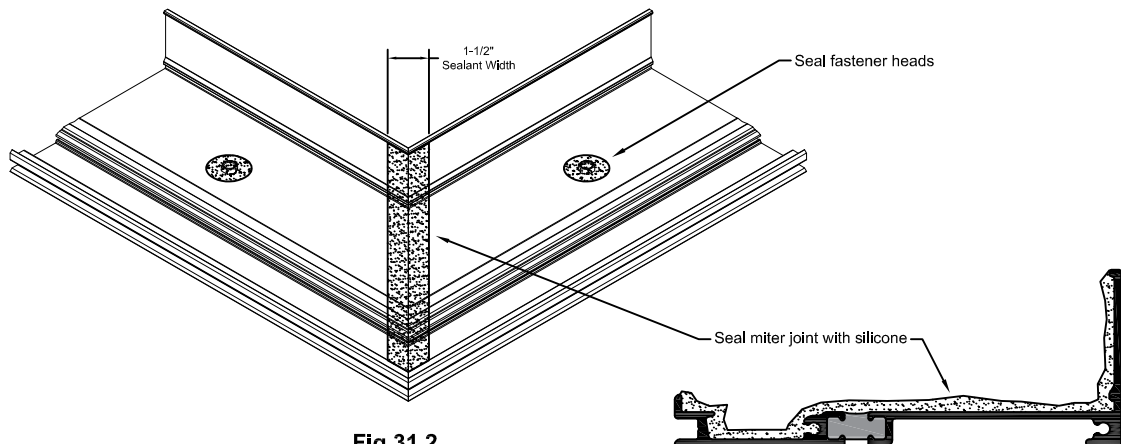
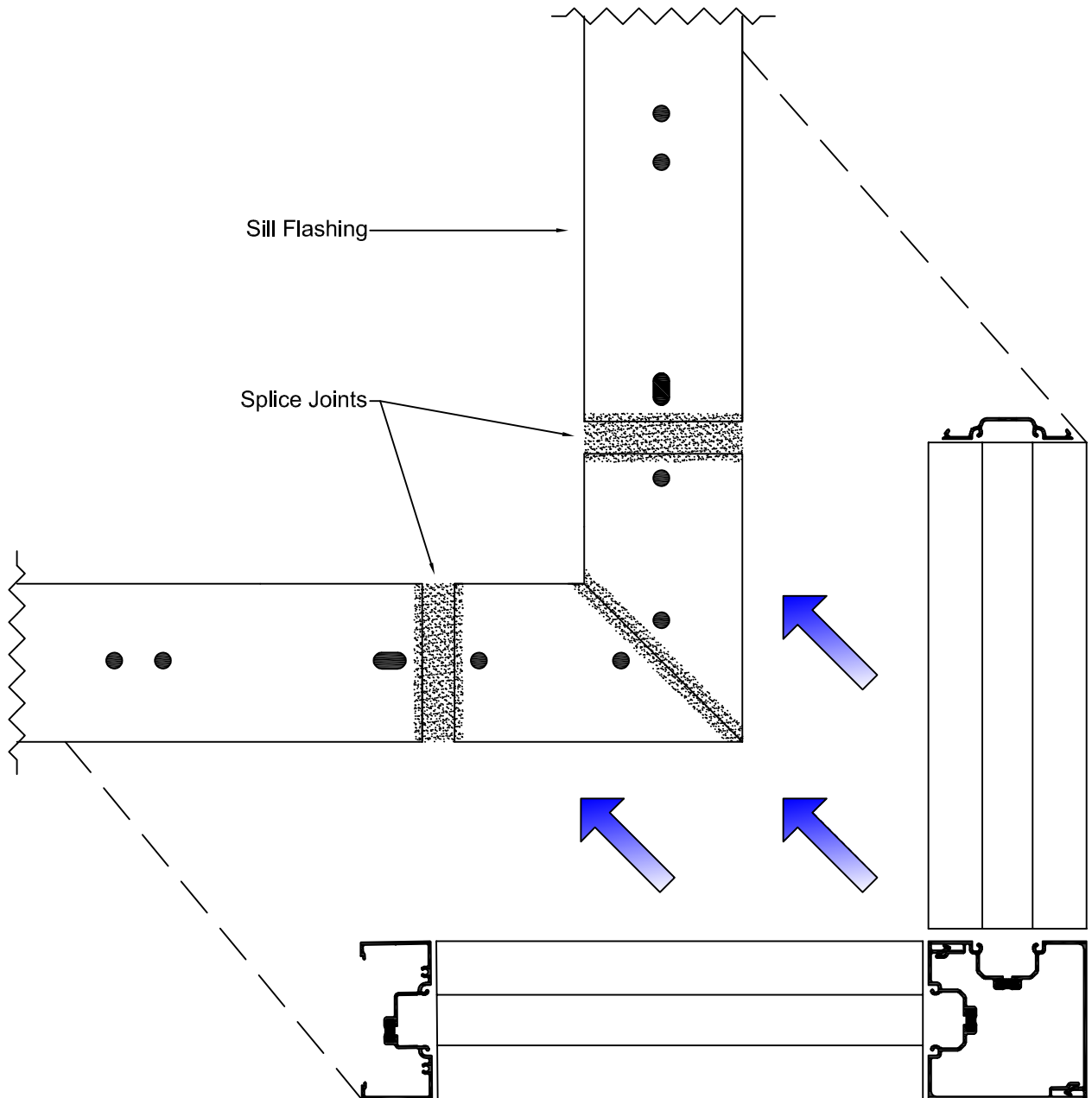

Fig.31.2

FRAME FABRICATION

Step 10: Assemble Corner Frames

- A. Assemble corner bay frames as a unit and set onto the sill flashing. See **Figs. 32.1**.
- Note: For 135 degree corners, deep pocket closures must be used (E14022 or T14022).**
- B. Complete the installation per standard instructions within this manual.



Assemble and install corner unit in one piece
(90° corner shown. 135° corner is similar)

Fig.32.1

FRAME ASSEMBLY

Step 11: Install Sill Flashing End Dams

- A. Install P2455 end dam at each end of sill flashing with (2) S196 #8 x $\frac{3}{8}$ " PH screws.
Set aside and allow sealant to cure.

NOTE:

If sill flashing is spliced, install end dams on jamb-end only. Refer to **Step 16, page 44** for splicing instructions.

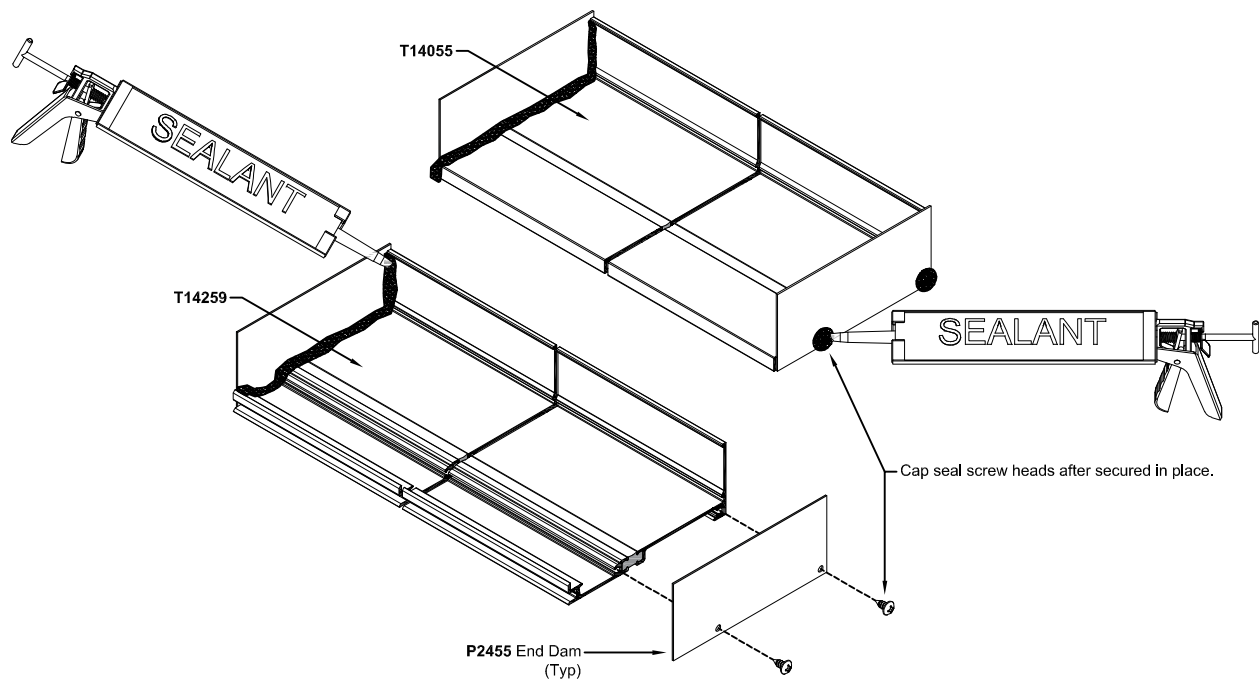

Fig.33.1

FRAME ASSEMBLY

Step 12: Optional High Sidelite Bases

Prior to assembling frames, follow these steps if using high sidelite base members

- A. Pre-attach P4563 pocket filler into the pocket of the vertical mullion and closure pocket members. Cut length of the filler can be determined by measuring from the bottom of the vertical mullion/closure pocket to the underside of the water diverter at the high sidelite base. **SEE Fig. 34.1**
- B. Attach snap-in adaptor T14248 to the T14441 horizontal (lower member of the sidelite base). **SEE Fig. 34.2**
- C. Seal joints between the adaptor and horizontal.
- D. Attach snap-in adaptor T14248 to the T14240 open back sill (upper member of the sidelite base). **SEE Fig. 34.2.**

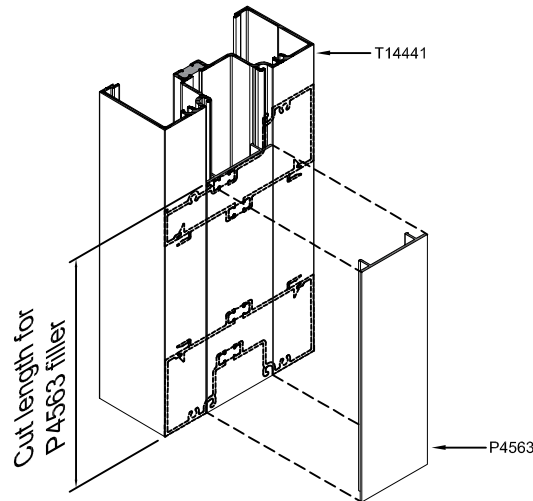

Fig.34.1

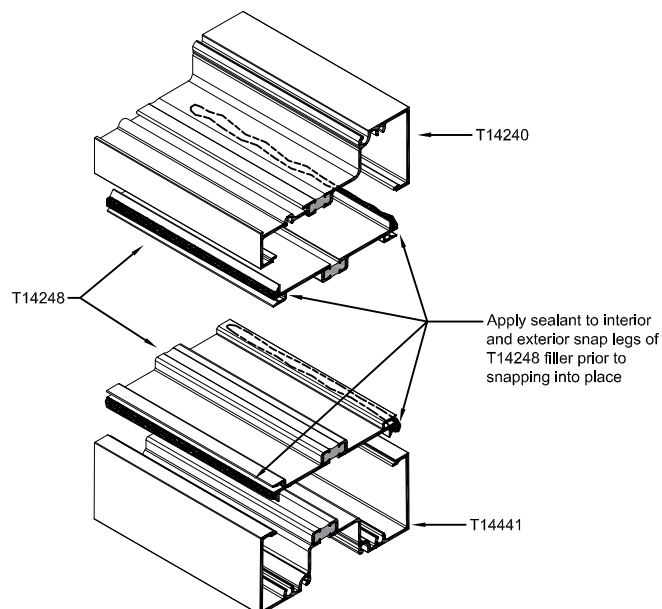

Fig.34.2

FRAME ASSEMBLY

Step 12: Optional High Sidelite Bases (Continued)

- E. Seal ends of the upper and lower members where it will contact the vertical mullion and closure pocket.
SEE Fig. 35.1 & Fig. 35.2.
- F. Before attaching the upper and lower members to the vertical, determine the height of the snap cover to be used. Attach the lower and upper members of the sidelite base to the vertical and closure pocket.
- G. *Optional:* Place one-sided closed cell adhesive tape along the edges of the vertical where the sidelite base covers will be installed. Place a bead of sealant onto the tape. **SEE Fig. 35.3.**
- H. Place a bead of sealant into the receptor areas of the snap-in adaptor. **SEE Fig. 35.3.**

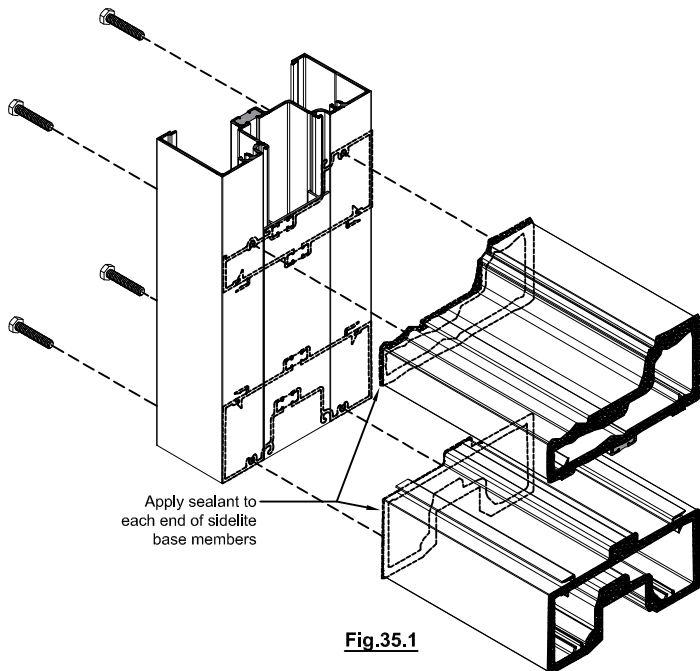

Fig.35.1
SPLINE ASSEMBLY

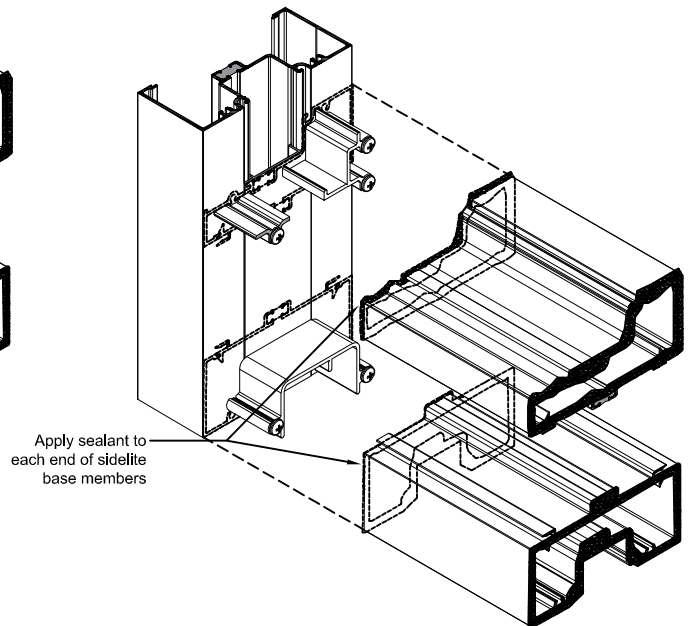

Fig.35.2
CLIP ASSEMBLY

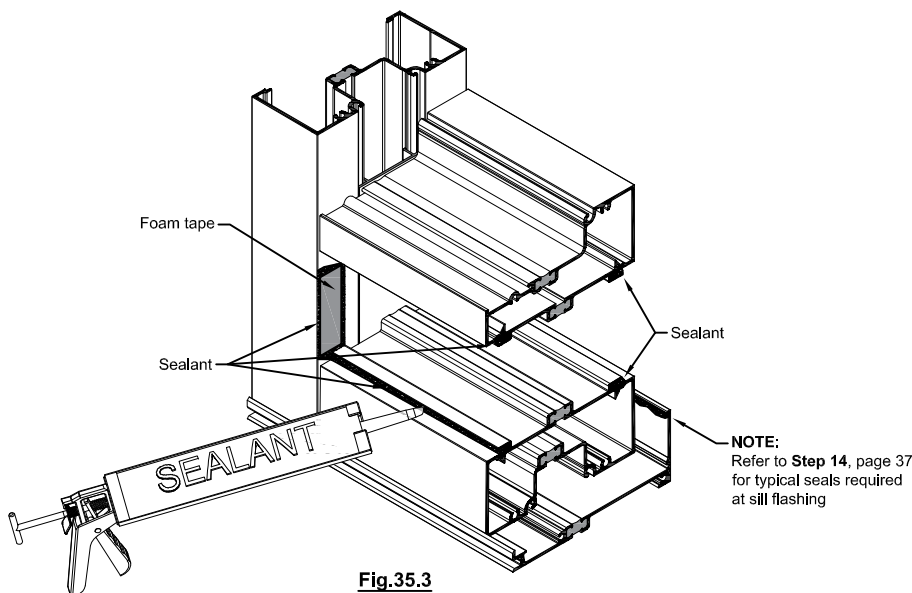

Fig.35.3

FRAME ASSEMBLY

Step 12: Optional High Sidelite Bases (Continued)

- I. Attach a snap cover or brake metal to the inside surface of the sidelite base. **SEE Fig. 36.1.**
- J. From the exterior, seal joints between the snap cover and vertical members. **SEE Fig. 36.2.**
- K. Attach a snap cover or brake metal to the exterior. **SEE Fig. 36.2.**

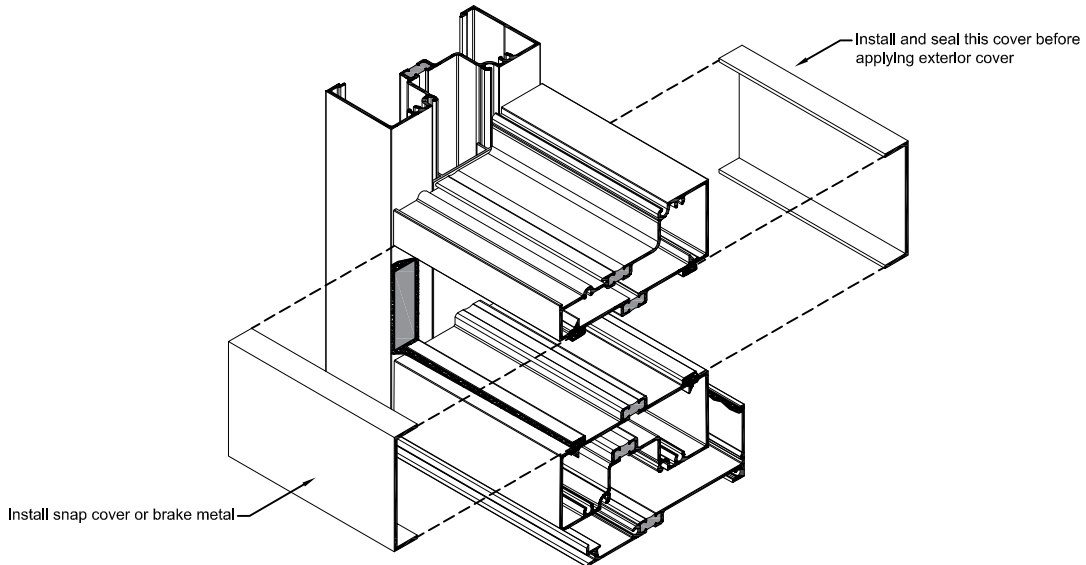

Fig.36.1

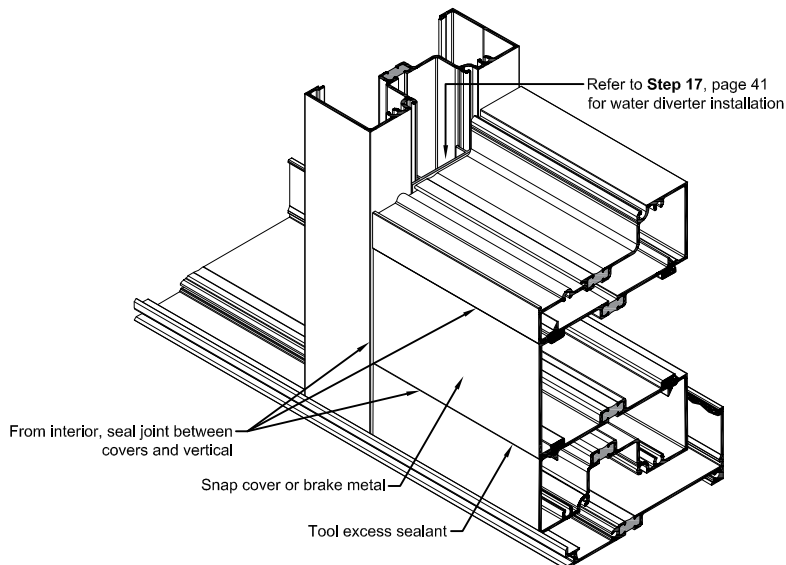

Fig.36.2

FRAME ASSEMBLY

Step 13: Optional Sidelight Base

- A. Install P4563 snap-in filler at bottom of vertical.
- B. Install backer rod in vertical pocket at top of P4563. Seal over to avoid water penetration into vertical.
- C. Drill for and attach P1137 clip as shown.
- D. Fabricate (2) $\frac{1}{4}$ " diameter weep holes in E14027.
- E. Fabricate anchor holes in E14027 as described in approved shop drawings.
- F. Install E14027 sidelite base anchor shoe into full bed of sealant and seal ends.
- G. Slide E14026 sidelite base over anchor shoe and clip.
- H. Fasten to clips with (2) #10 FH UC screws at each end.
- I. Apply a continuous bead of sealant at interior snap receiver.
- J. Snap-in interior stop.
- K. Install setting blocks, interior gaskets and glaze.
- L. Install gasket in exterior glass stop and snap in place.

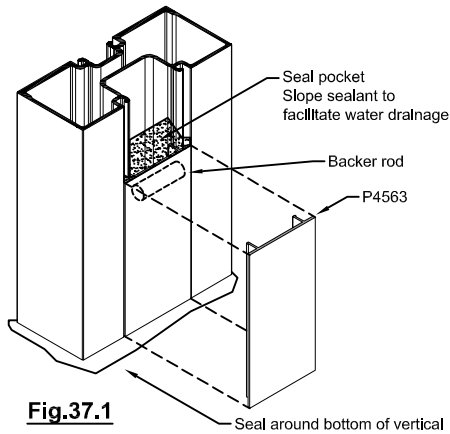

Fig.37.1

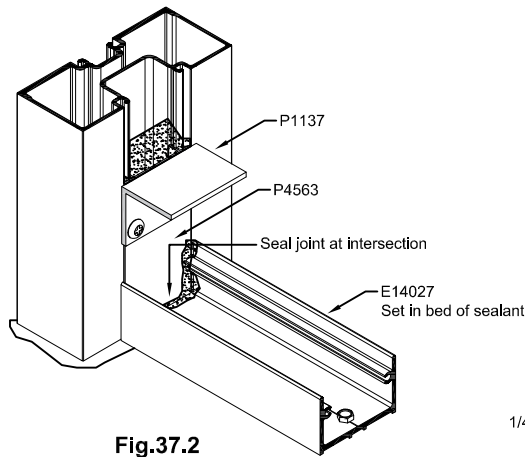

Fig.37.2

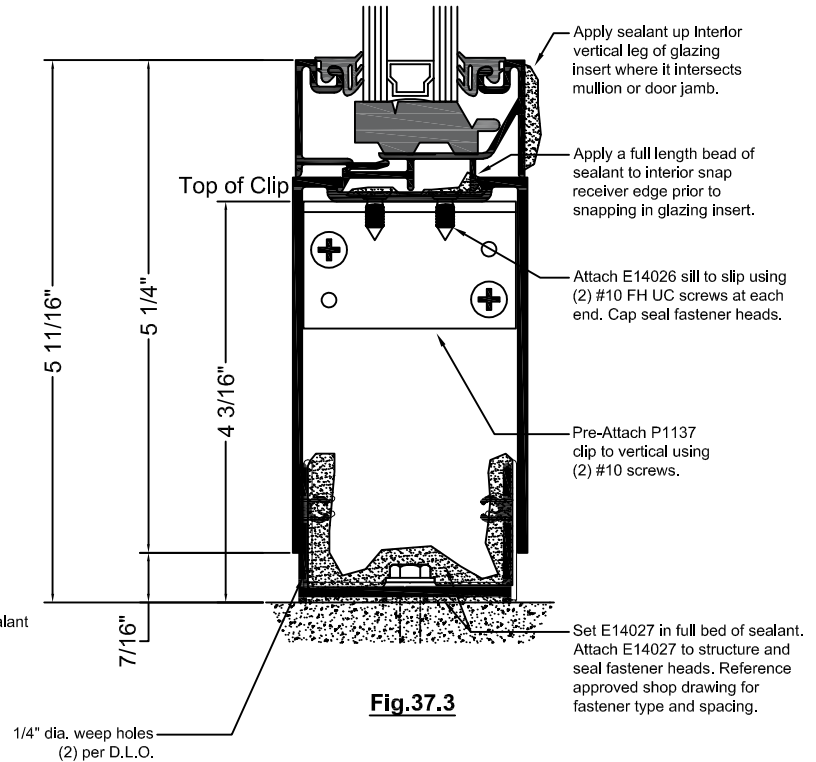

Fig.37.3

FRAME ASSEMBLY

Step 14: Assemble Frames

Screw Spline Assembly

- A. Clean all mating surfaces on horizontal & vertical.
- B. Apply sealant to ends of the head, horizontal and sill members prior to attaching to the vertical members. **SEE Fig. 38.1.**
- C. Attach head, horizontal and sill members to the vertical and closure pocket members with S449 #10-24 x 1" IND HEX Head Type F frame assembly screw.
- D. Tool sealant at each joint.

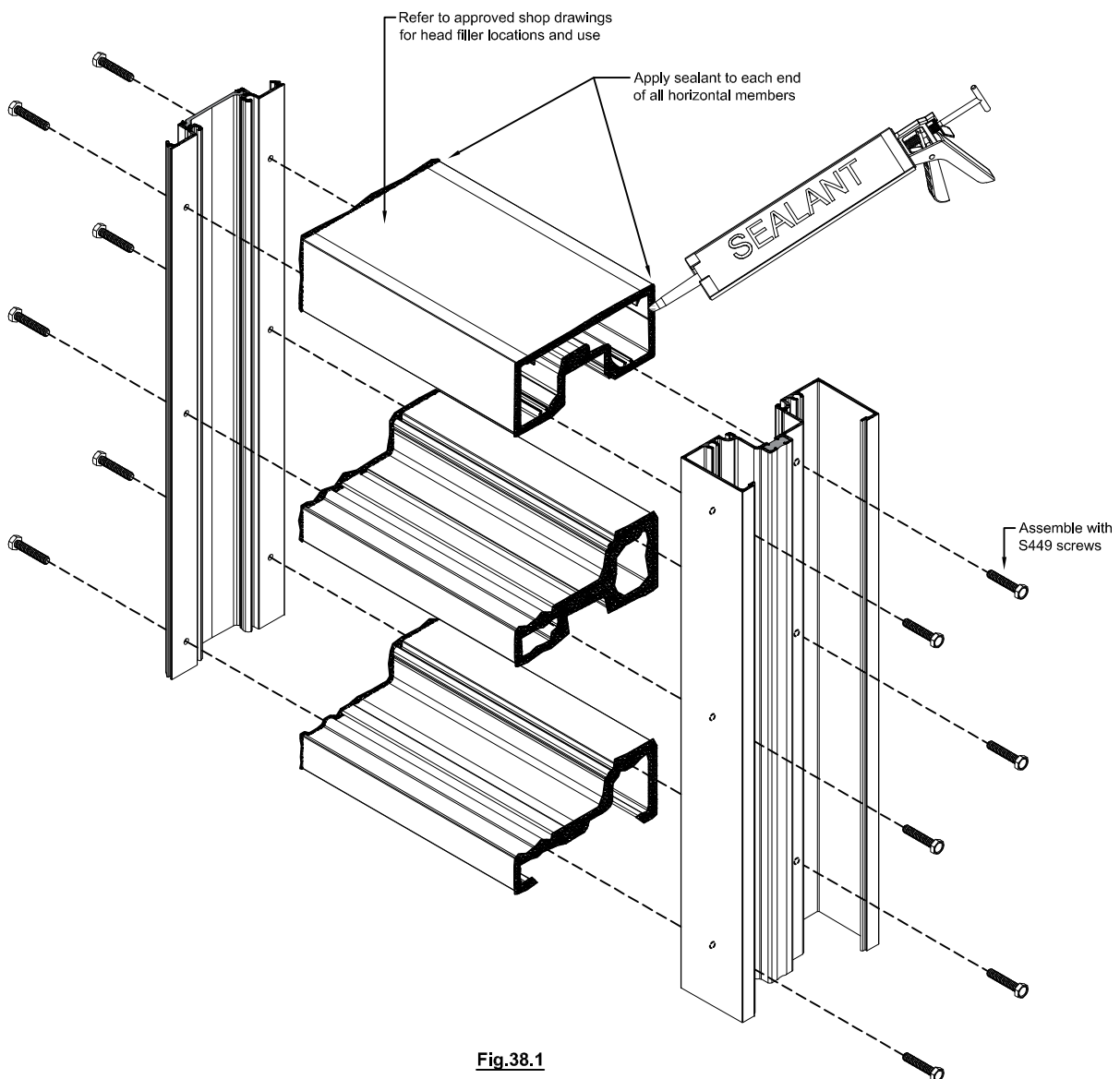

FRAME FABRICATION

Step 14: Assemble Frames (Continued)

Shear Block Assembly

- A. Install shear blocks onto vertical and closure pocket members with S009 #10 x 1 $\frac{3}{4}$ " PH screw as shown in **Fig. 39.1**.
- B. Clean all mating surfaces on horizontal, vertical and shear block.
- C. Apply sealant to ends of the head, horizontal and sill members and to perimeter of shear blocks prior to attaching the horizontal members to the vertical members. See **Fig. 39.2**.
- D. Install head, horizontal and sill members over the shear blocks.
- E. Match drill tap hole in head shear block with drill #14 (.182 dia) for #12 screw.
- F. Match drill tap hole in horizontal and sill shear blocks with drill #23 (.154 dia) for #10 screw.

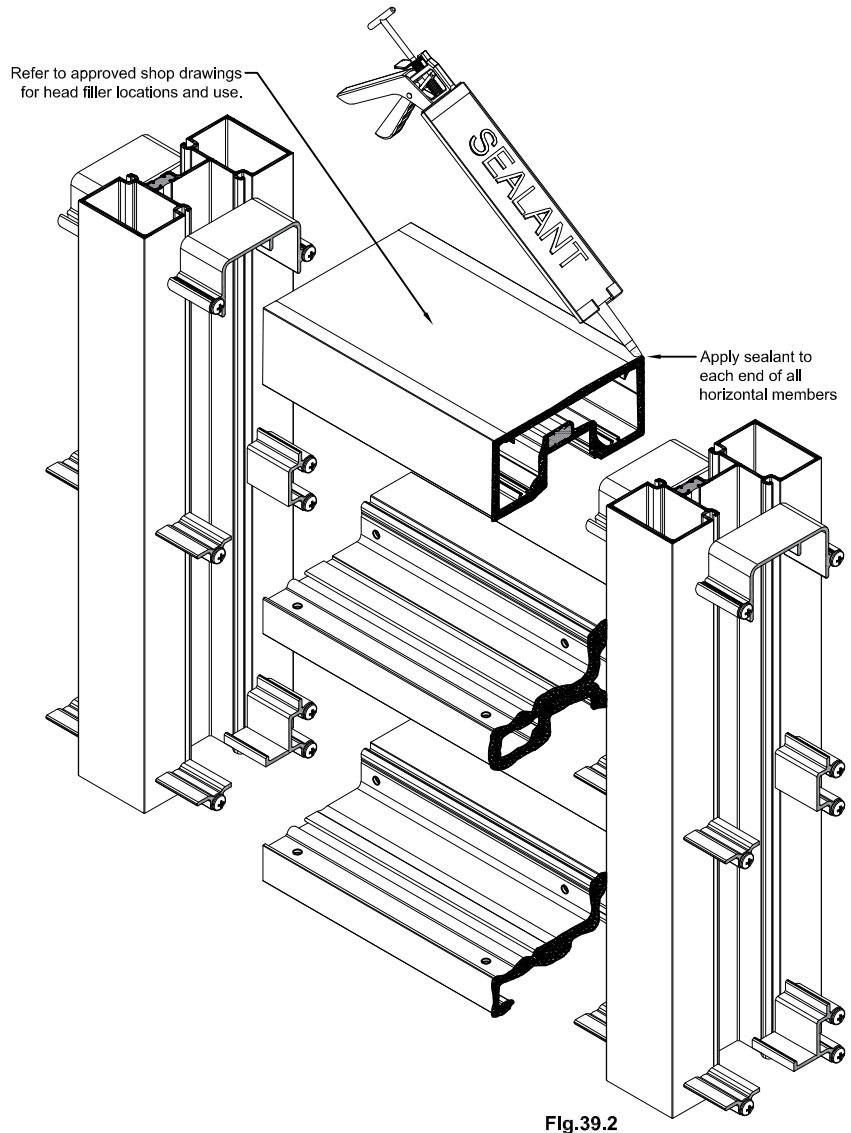
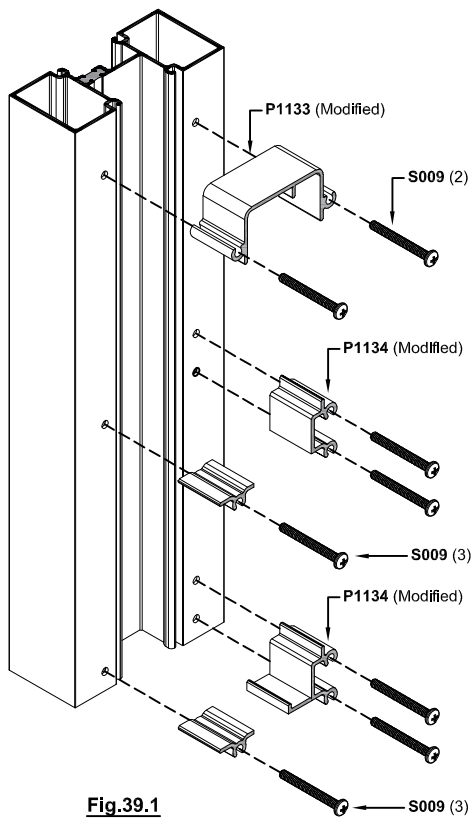

FRAME ASSEMBLY

Step 14: Assemble Frames (Continued)

Shear Block Assembly (Continued)

- G. Secure head member to shear block with (1) S149 #12 x $\frac{3}{4}$ " FH screw. Secure horizontal and sill members with (2) S191 #10 x $\frac{1}{2}$ " truss head screw. See **Fig. 40.1**.
- H. Cap seal heads of screws at horizontal and sill members.

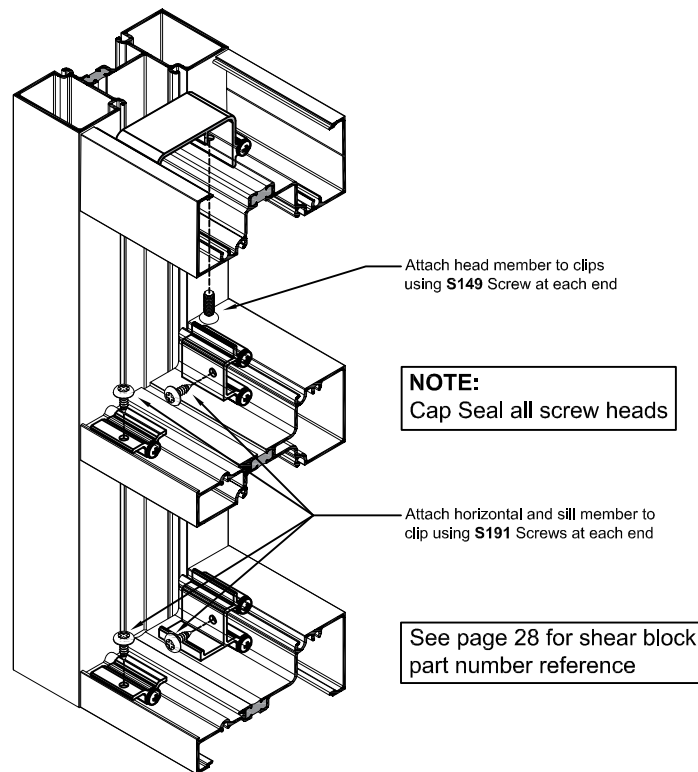

Fig.40.1

FRAME ASSEMBLY

INSIDE GLAZING GUIDELINES

For inside glazing applications, refer to **Fig. 41.1** for screw spline assembly and **Fig. 42.1** for shear block assembly. Follow standard instructions for fabrication, assembly and glazing of inside glazed applications.

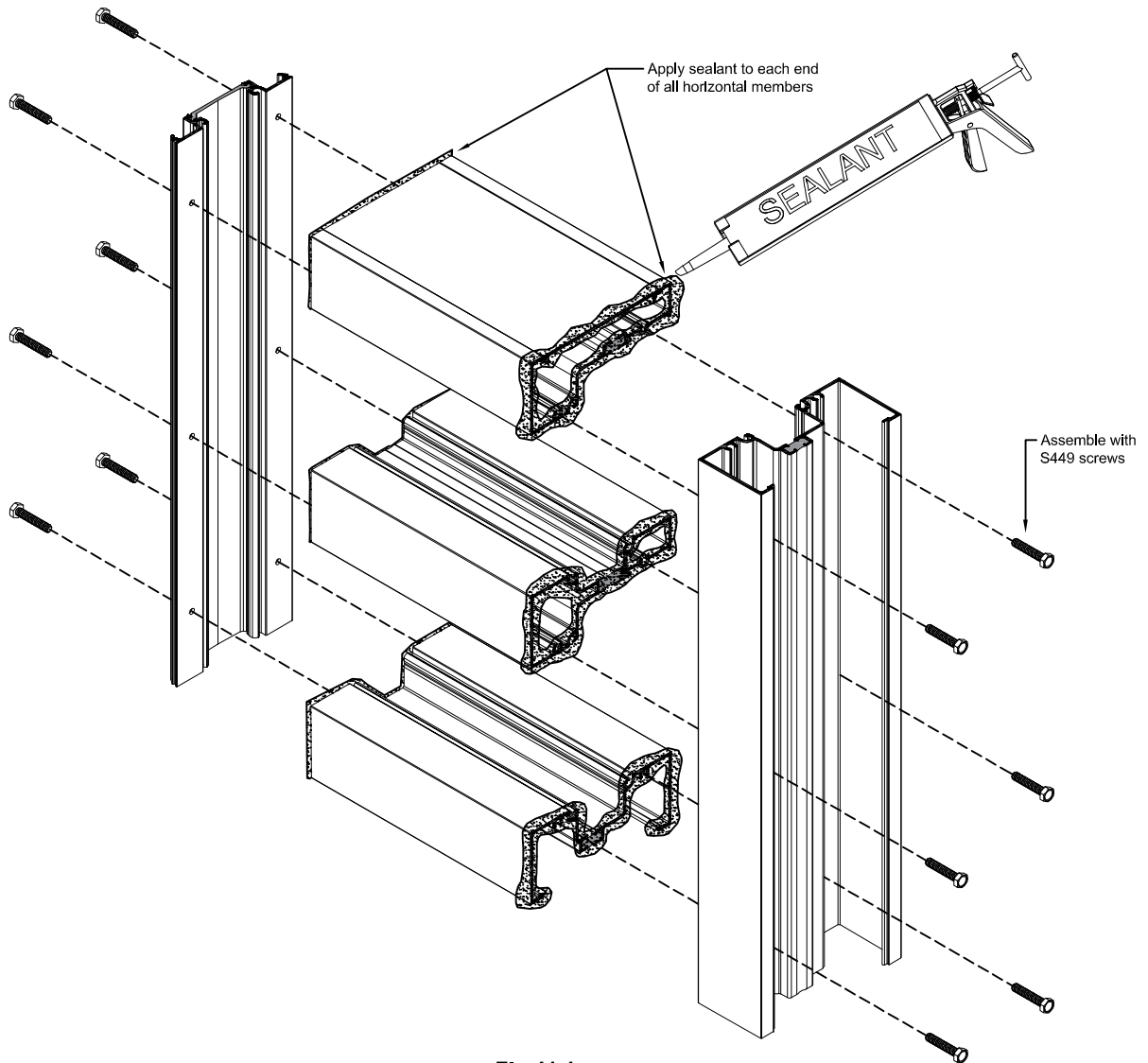
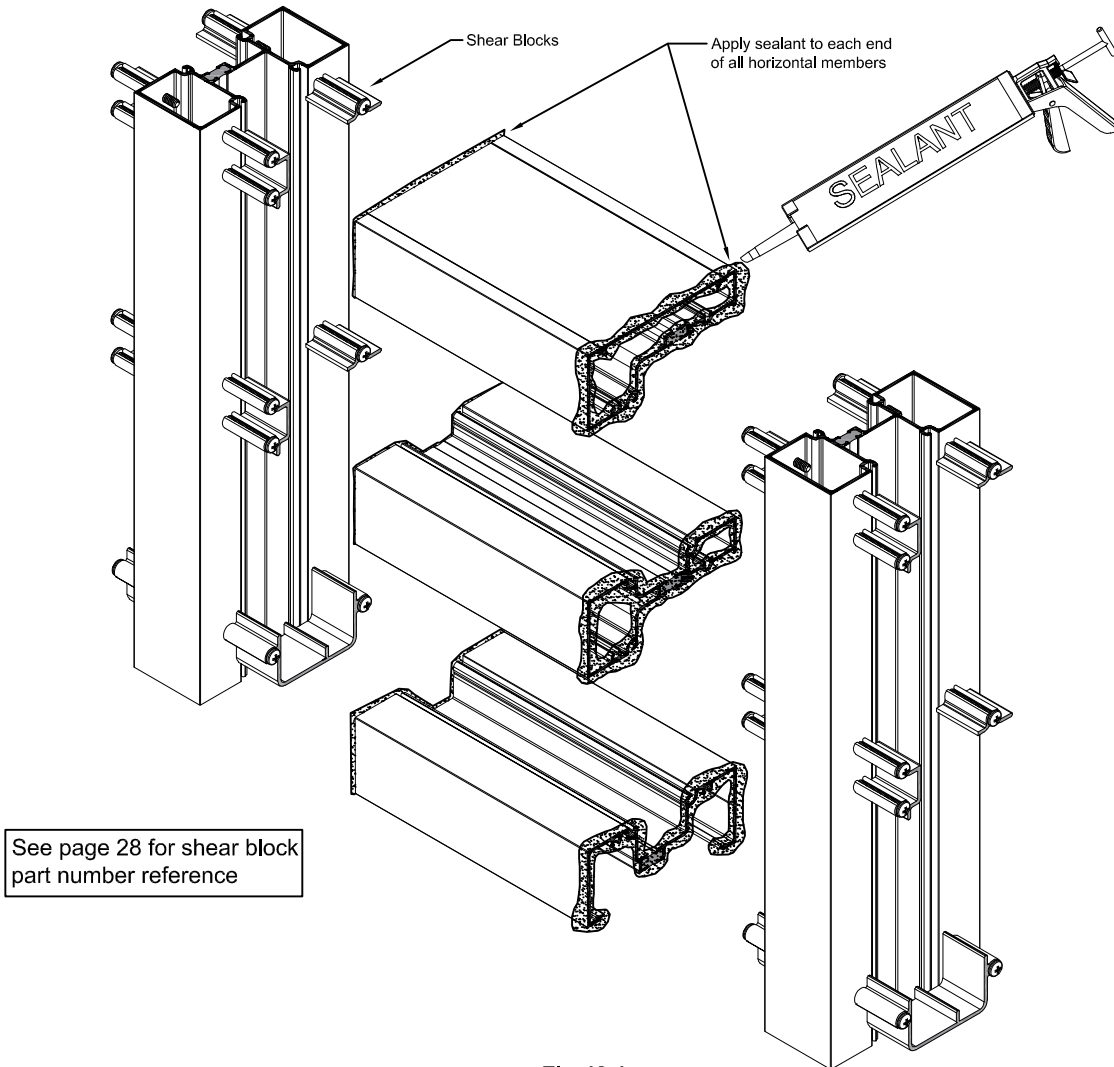

Fig.41.1

FRAME ASSEMBLY



FRAME INSTALLATION

Step 15: Install Sill Flashing (If required)

- A. Center the sill flashing in the opening. If sill flashing is spliced, be sure the joint at the jamb is per approved shop drawings (jamb caulk joint minus $\frac{1}{8}$ "). **If there is an entrance door in the opening, leave a gap in the sill flashing for the door frame to be installed and refer to Step 15, page 49 for sealing instructions.** Splice joint to be $\frac{3}{8}$ " minimum.
- B. At the highest point of the sill (smallest rough opening height), shim the sill flashing with a minimum $\frac{1}{4}$ " shim space. Sill flashing must be installed level side to side and front to back.
- C. Shim tight between the sill flashing end dam and building condition to ensure end dam is not dislodged during frame installation. Remove shim after frames are set in place.
- D. Anchor sill flashing to building substrate per approved shop drawings. Cap seal anchors after installation. Where the sill flashing abuts a door jamb, the sill flashing anchor must be located within 6" of the door jamb.

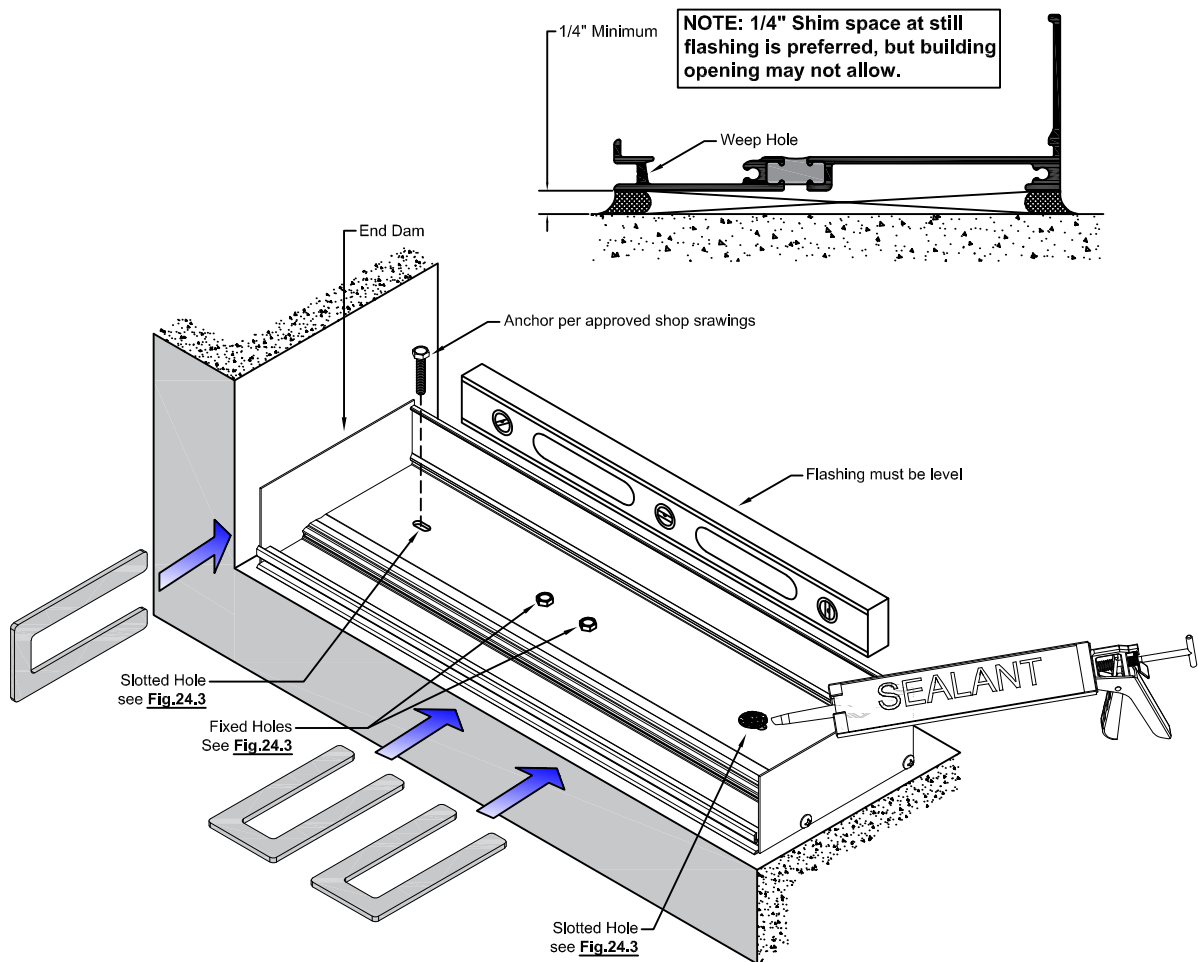

Fig.43.1

FRAME INSTALLATION

Step 16: Sill Flashing Splice

Continue installing sill flashing per Step 12 across the opening.

- Lay P3444 silicone sheet into sill flashing at splice location (center of D.L.O.) and cut to length.
- Install backer rod under the sill flashing at the splice joint.
- Clean surfaces where splice will be applied. Apply sealant as shown in **Fig. 44.1**.
- Set silicone splice sleeve in place and tool sealant. Seal front and back joints.
- Do not locate a splice directly below a vertical mullion. Center line of D.L.O. is preferred.

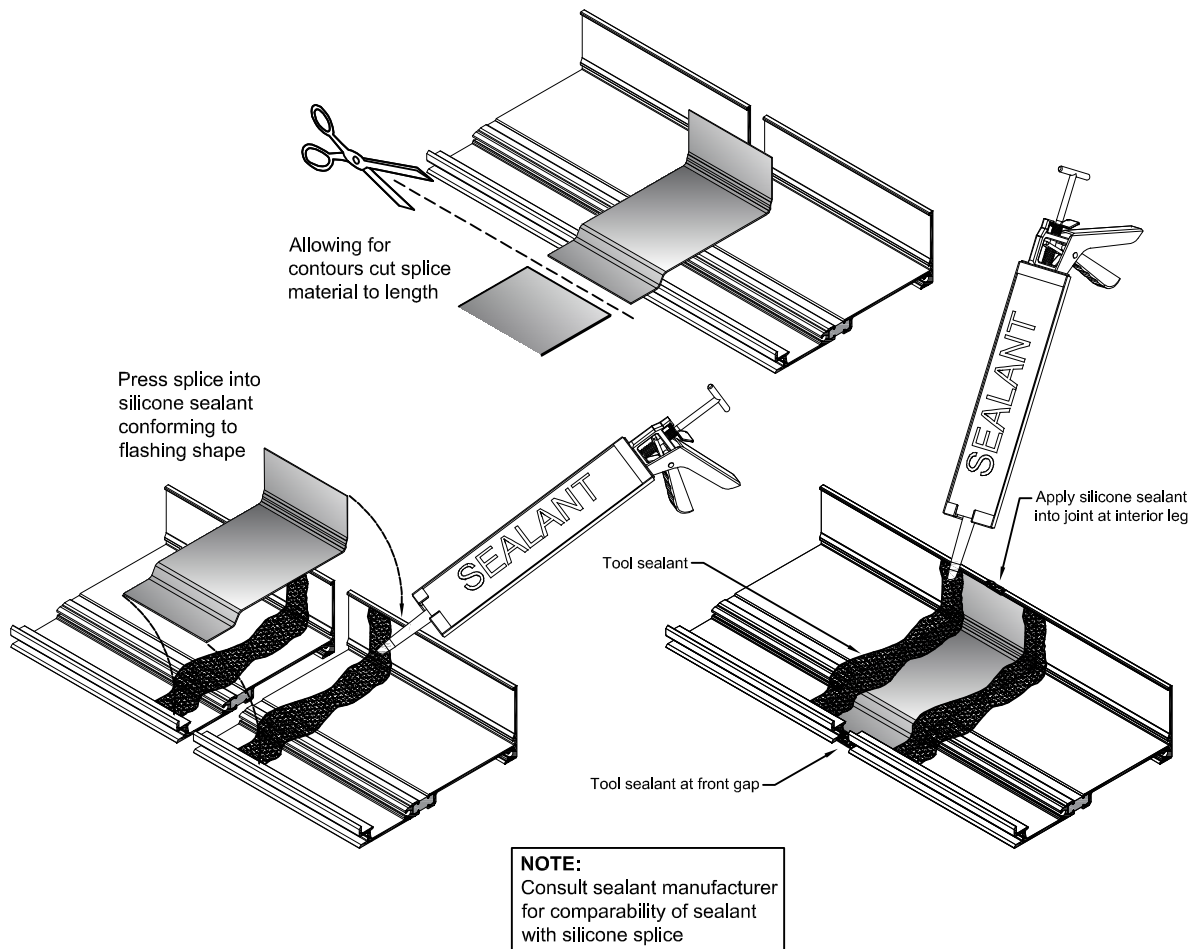

Fig.44.1

FRAME INSTALLATION

Step 17: Install Frames

- A. Starting on one side of the opening, apply a bead of silicone to the back leg of the sill flashing and the end dam prior to installing each frame. Apply a sealant bead on the back leg of the flashing only for the frame to be installed.
- B. Lift the first frame onto the sill flashing, snug against the end dam.
- C. Lift each frame onto the sill flashing and engage with the previous frame.
- D. Check to ensure frame is plumb, level and jamb caulk joint is per approved shop drawings.
- E. Shim head and jamb at anchor points and attach to the building structure. Size, quantity and location of anchors are per approved shop drawings. Remove shims between sill flashing end dams and secure before proceeding.
- F. When the frame is anchored to the structure, apply the exterior perimeter seal at the head, sill and jambs. Interior perimeter seal must be applied to the head, sill and jambs.

NOTE: When using P4543A, make sure clearance holes are made in the snap-in filler to avoid the sill flashing anchors.

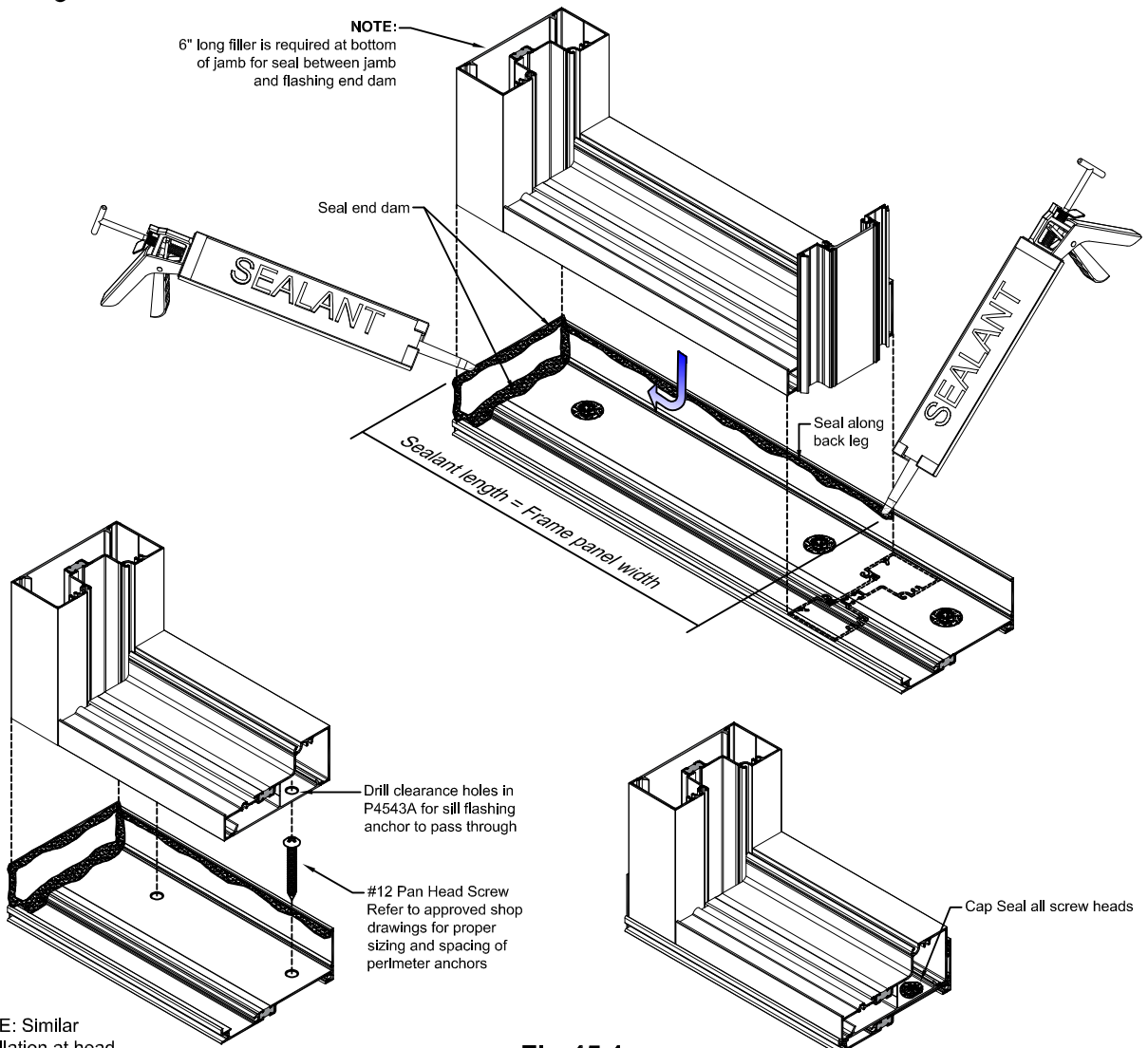

NOTE: Similar installation at head condition

Fig.45.1

FRAME INSTALLATION

Step 17: Install Frames (Continued)

Frame installation when using the optional T14055 sill flashing.

- G. Install frame units as directed in steps A and B on page 45.
- H. Push frame tight to vertical fin of sill flashing and match drill through sill anchor holes into sill flashing. See **Fig. 46.1**. Sill anchor not by Tubelite and is to be sized according to project loading requirements.
- I. Shim between sill and flashing centered on anchor. See **Fig. 46.2**.
- J. Inject sealant into anchor hole to cover hole in flashing. See **Fig. 46.2**.
- K. Apply sealant to threads of fastener and secure frame to sill flashing. See **Fig. 46.3**.
- L. Cap seal all fastener heads. See **Fig. 46.4**.

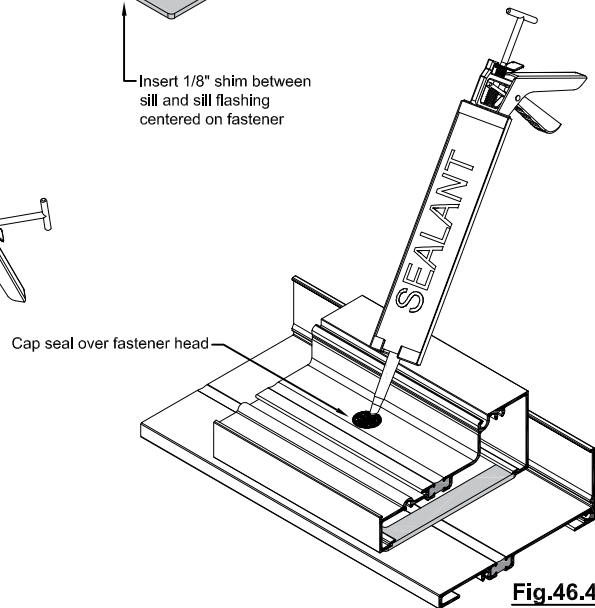
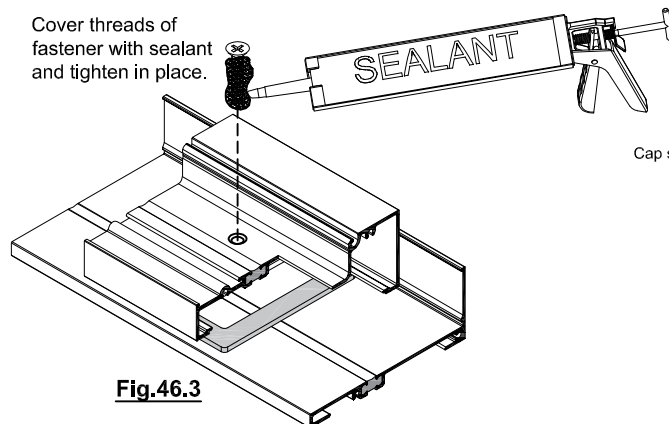
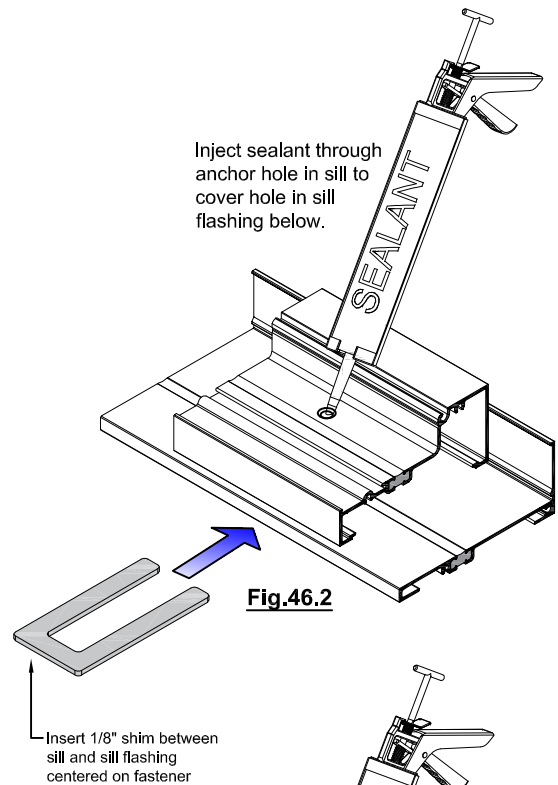
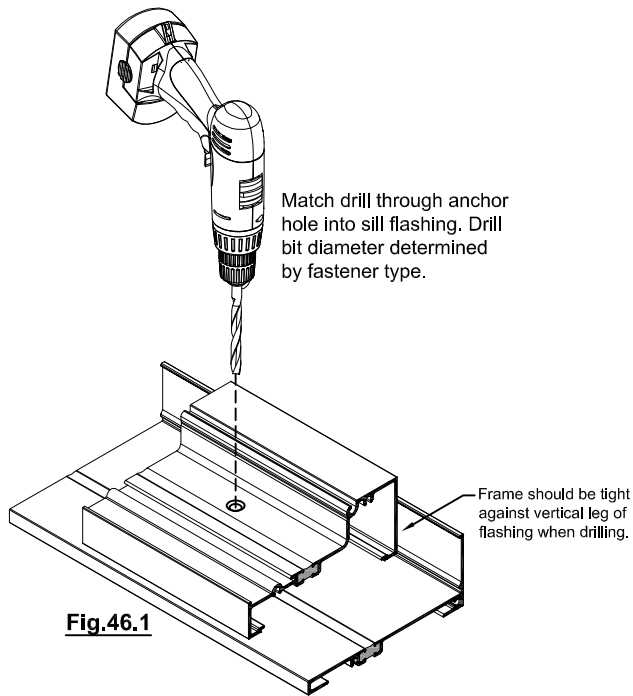
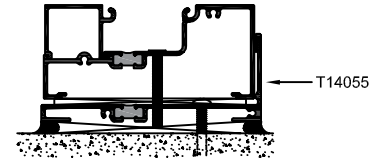

FRAME INSTALLATION

Step 18: Sealing Sill Flashing at Door Jamb

- A. Install door frame into the opening where sill flashing is discontinued.
- B. Seal the bottom of the door jamb mullion to the building substrate and to the sill flashing.
- C. Fill the door jamb cavity completely and marry to the sill flashing.

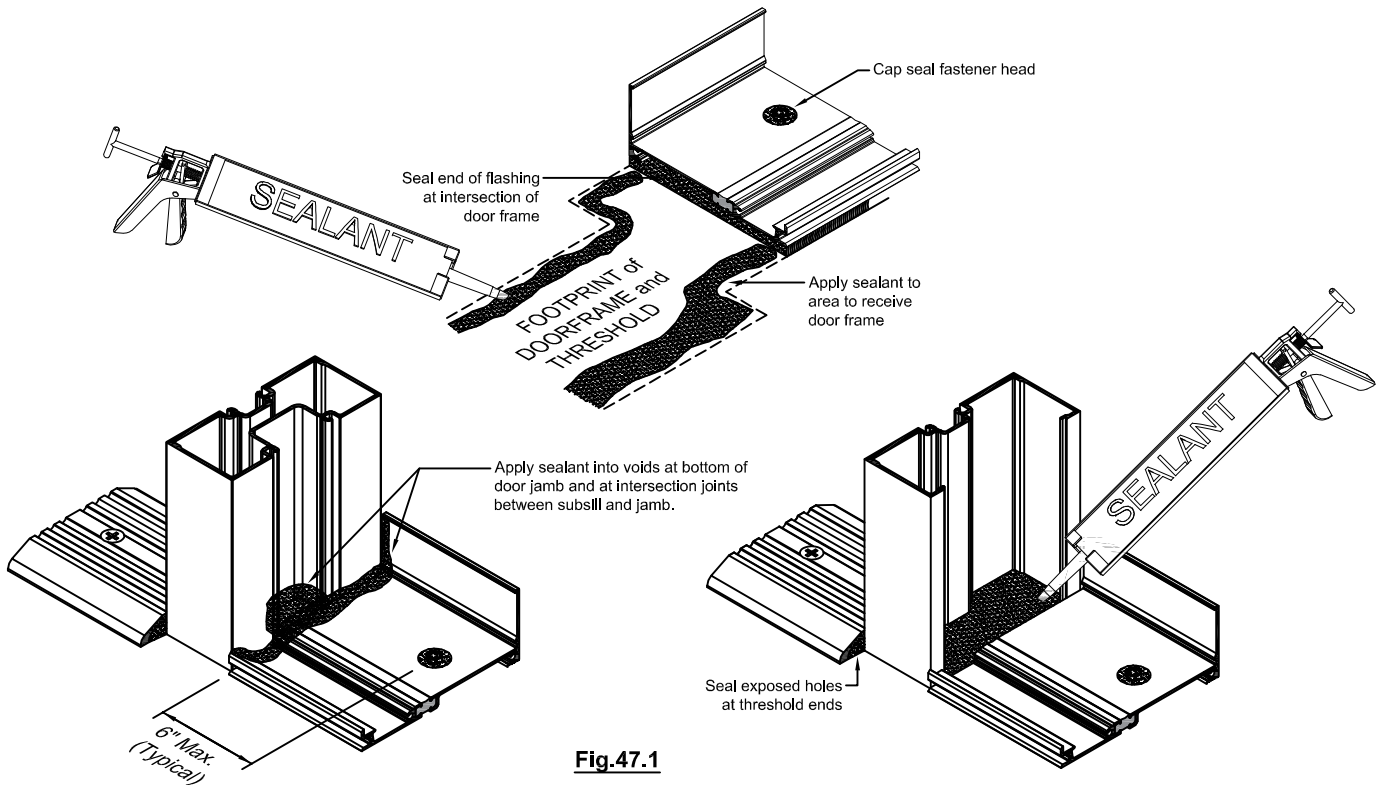

NOTE:

When a 'Knee Wall' occurs within an elevation, the sill flashing must be sealed to intersecting vertical members as shown in [Fig.47.2](#)

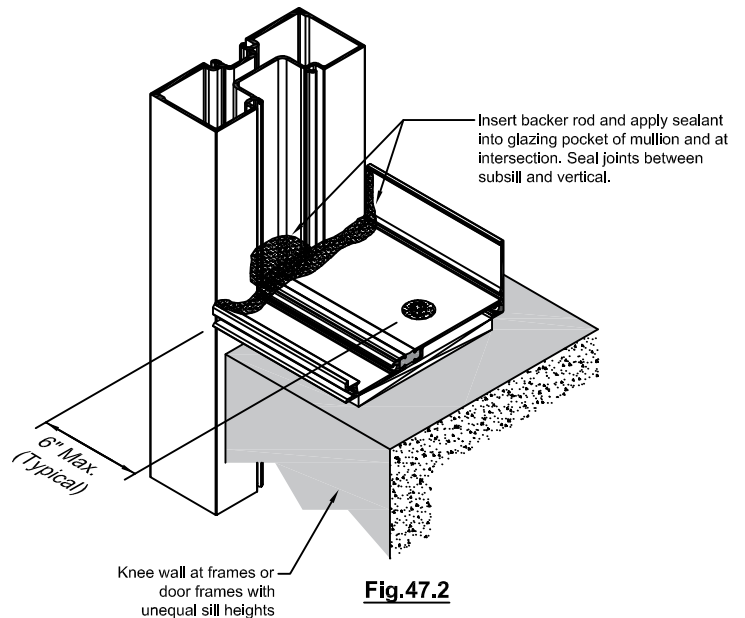

GLAZING

Step 19: Glazing Preparation

- A. Remove any debris from the glazing pockets.
- B. Trim excess silicone from edges of glazing units to allow for maximum glazing clearance.

Glazing pockets are designed to accept IGU's up to and including 1-1/8" thick. Refer to our online details for a full list of glazing size options for this system.

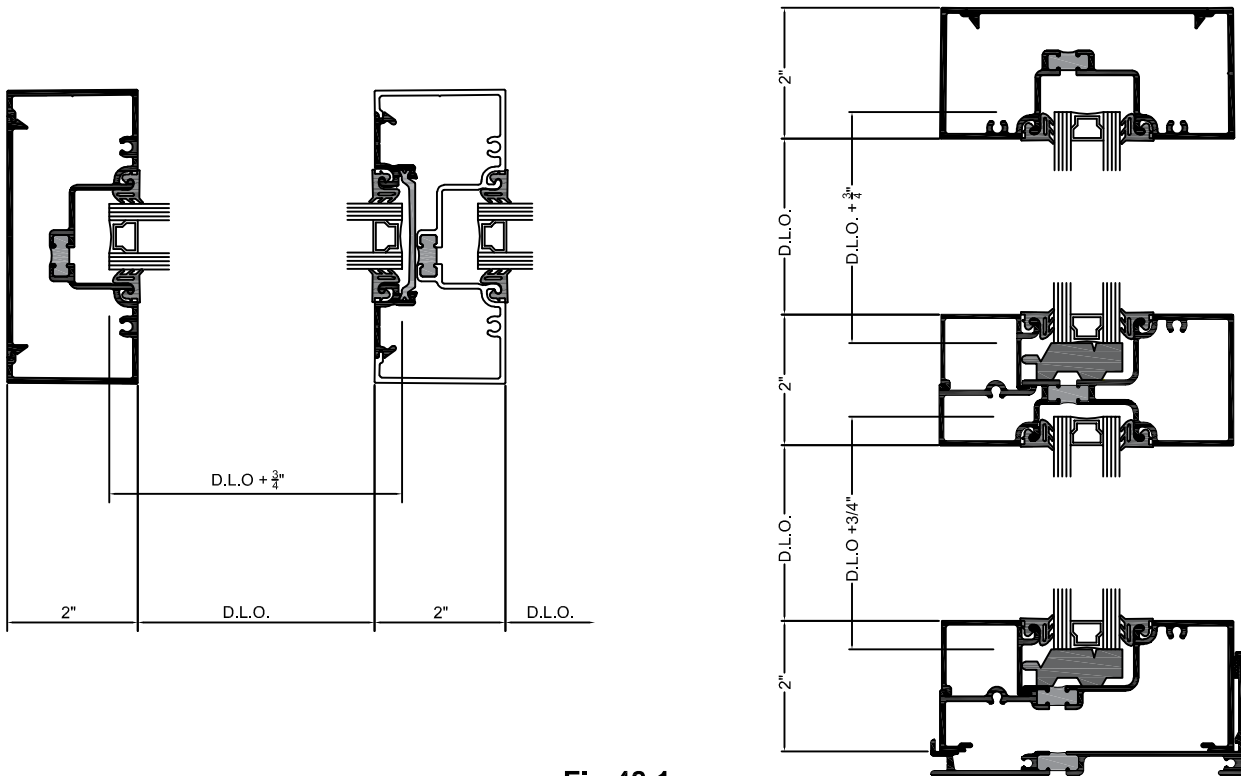

Fig 48.1
GLASS LITE SIZES

GLAZING

Step 20: Installing the Glazing Units

NOTE: Glazing must be done from bottom of frame up.

- A. Seal the corners of the previously installed gaskets (refer to Step 22, page 51.).
- B. Set the glass by installing into the deep pocket of the vertical first, then carefully sliding into the shallow pocket. Set glass onto (2) setting blocks located at quarter points or per approved shop drawings. Consult glass manufacturer if glass size exceeds 40 sq. ft.
- C. In applications where glass shifting is anticipated through seismic activity or other forces acting on the frame, install P1917 anti-walk blocks into the deep pocket side of the vertical per glazing manufacturer recommendations.
- D. Install remaining gaskets on the vertical sides of the glass, holding back at the bottom to allow for glass stop installation.
- E. Install glass stop at the bottom of the lite.
- F. Pump sealant into glazing reglet 1" away from each corner and the horizontal-to-vertical joint from the water diverter up to the glazing reglet.
- G. Finish installing gaskets at top and bottom of D.L.O.
- H. Repeat steps 20 A-G for the remaining row of lites.
- I. Prior to glazing the next row of lites, install water diverter P1135 at ends of intermediate horizontals. See **Fig. 49.1**.

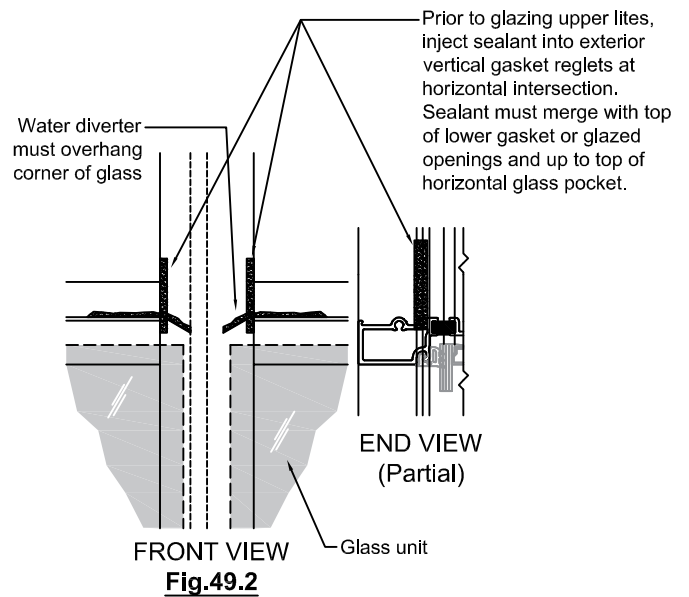
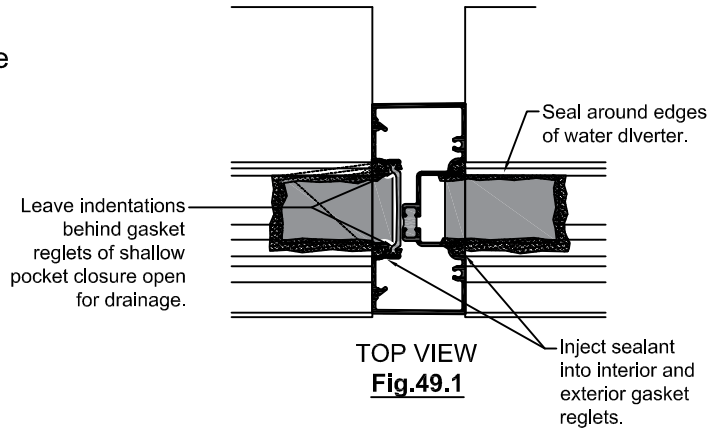

NOTE: Position water diverter to cover glass corner. Seal diverter to horizontal, leaving the gap at the front and side open in the vertical glazing pocket. See **Fig. 49.1 & 49.2**. (Also see isometric details on page 50)

GLAZING

Step 21: Installing the Glazing Units (Continued)

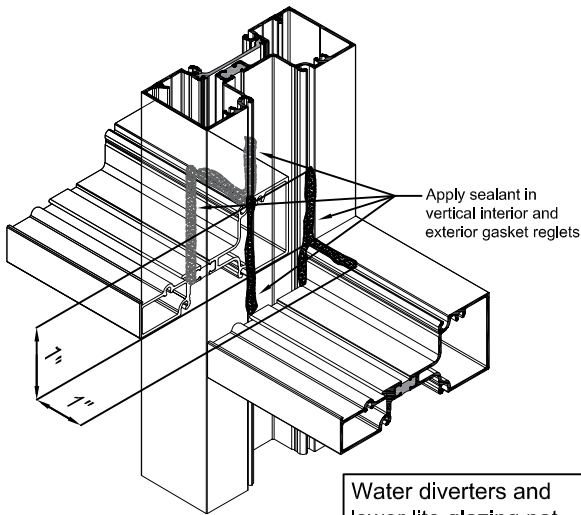

Fig.50.1

Water diverters and lower lite glazing not shown for detail clarity

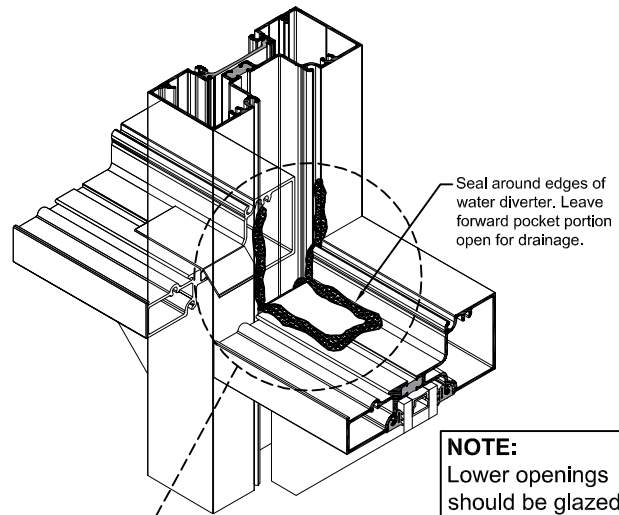

Fig.50.2

NOTE:
Lower openings should be glazed prior to installing water diverters in upper openings.

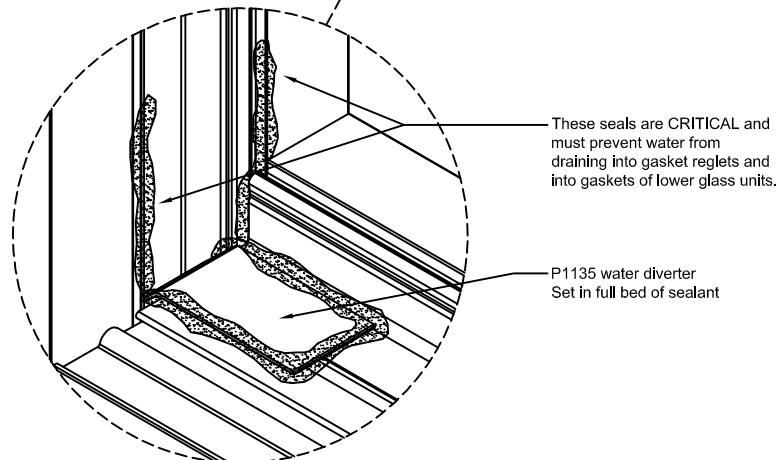

Fig.50.3

GLAZING

Step 22: Install Gaskets

- A. Install glazing gasket on one side of the framing member, depending upon direction of glazing.
1. For inside glazing, install gaskets on exterior side of framing first.
 2. For outside glazing, install gaskets on interior side of framing first.

DO NOT STRETCH GASKETS WHEN INSTALLING.
Start at the center of D.L.O. and work towards the ends.

Allowance = $\frac{1}{8}$ " extra length per foot of D.L.O.

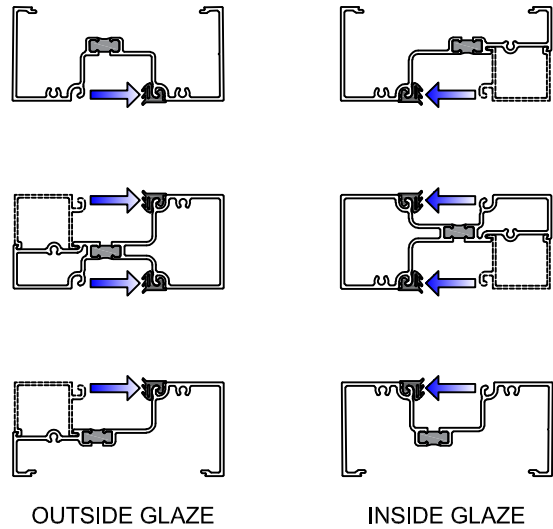

Fig. 51.1

IMPORTANT NOTE: Clean ends of gaskets with IPA prior to sealing the corners.

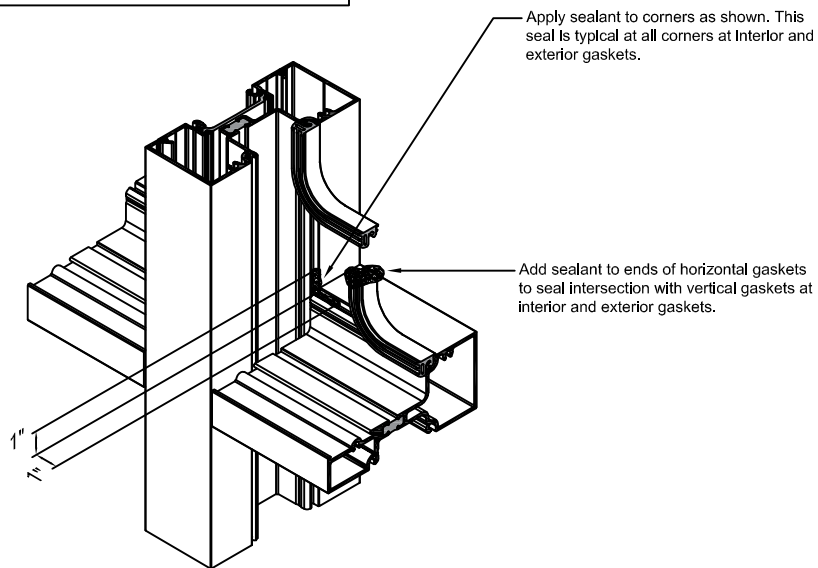
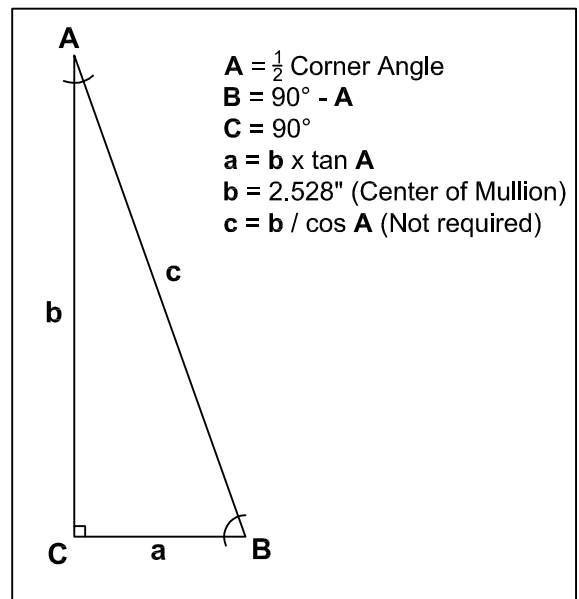
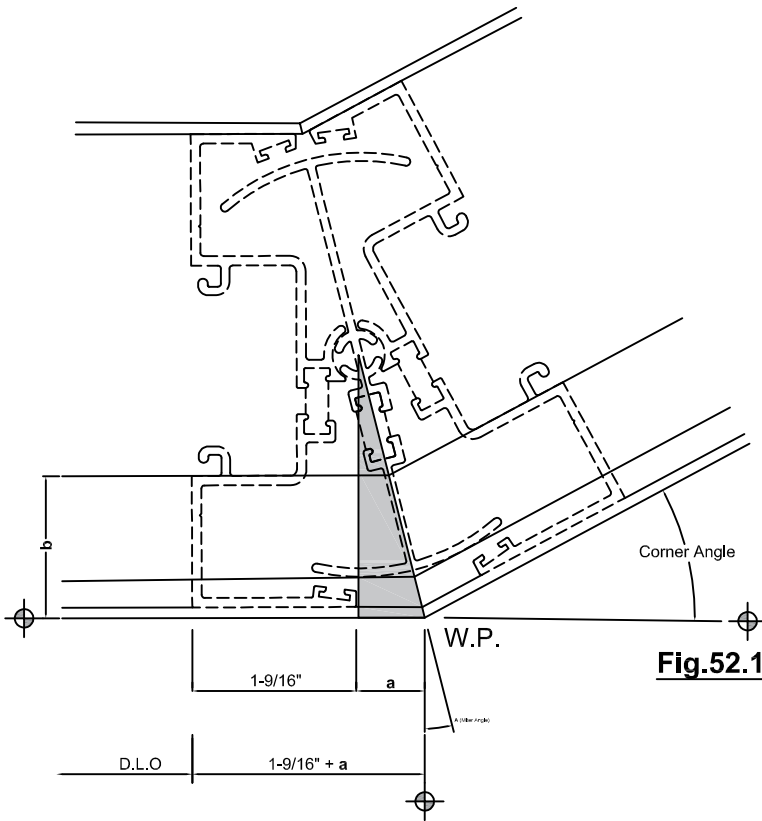

Fig. 51.2

OPTIONAL ROTATIONAL MULLIONS

Step 1: Sill Flashing Fabrication & Installation

- A. Determine cut length of the sill flashing at the splayed condition. See **Fig. 52.1**. The sill flashing is mitered and butt tight at the corner.
- B. Install flashing per instructions in Step 11, page 43. Anchor the sill flashing to the building substrate each side of the corner. Seal heads of fasteners.
- C. Seal entire miter joint at sill flashing, tooling the sealant over the joint. See **Fig. 52.2**.



NOTE: If rotational mullion is utilized at only one corner on a frame in lieu of a splayed frame with many segments, Tubelite recommends splicing the sill flashing on either side of the corner as per typical corner conditions.

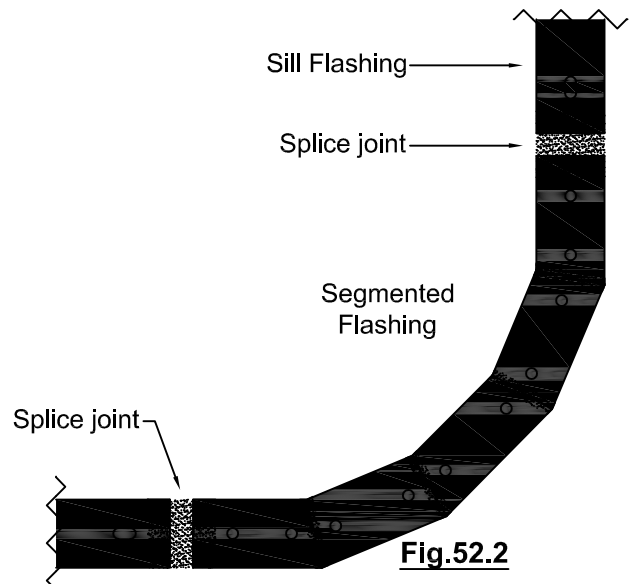

OPTIONAL ROTATIONAL MULLIONS

Step 2: Assemble Frames

- A. Install inner rotational mullion (E14247 or T14247) onto the sill flashing.
- B. Assemble frames on each side of the splayed condition. Make sure the wiper gaskets (P1221) are installed into the outer rotational mullions.
- C. Set frames into the sill flashing and against the inner rotational mullion until they lock into place.
- D. Once frame units are installed and in position, drill and countersink for #10 F.H. screw 6" from end and 24" on center. See **Fig. 53.1**.
- E. Complete the installation per standard instructions within this manual.

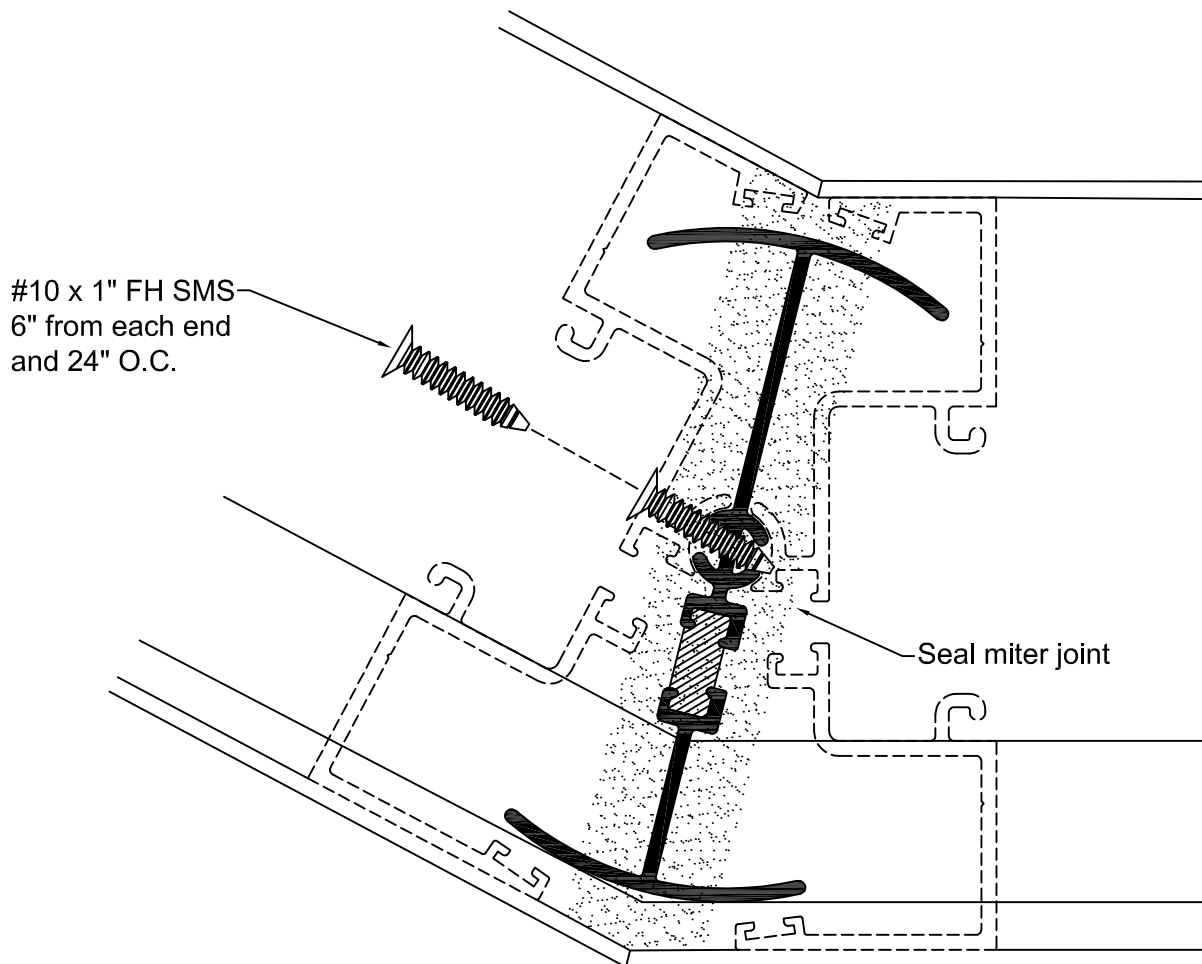

Fig.53.1

OPTIONAL THERMAL ENHANCEMENT

OPTIONAL THERMAL ENHANCEMENT

The T14000 system can be modified for enhanced CRF and U-value performance by using the optional A244040 and A245050 filler as shown in the details below. Refer to our website for the most current test reports and CAD details.

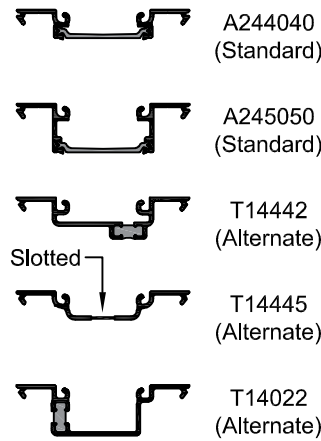

Fig 54.1
 THERMAL FILLER OPTIONS

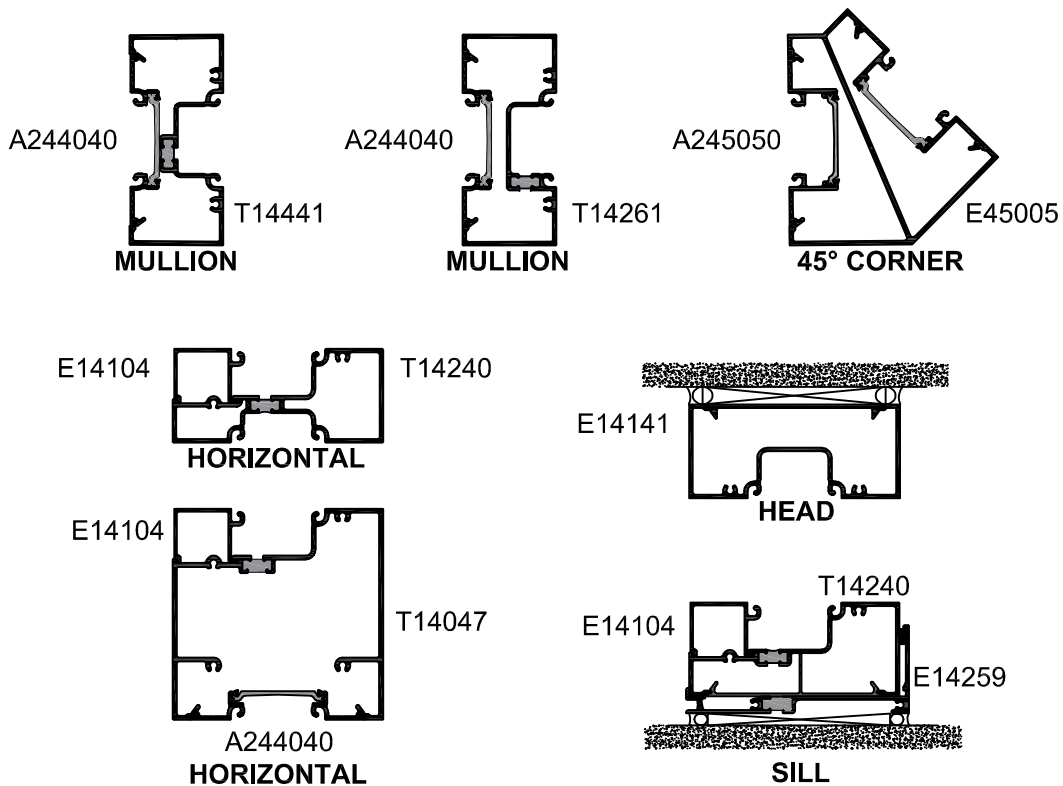

Fig 54.2
 STANDARD ASSEMBLIES